

**\*ARMY TM 9-2355-335-23-2  
AIR FORCE TO 36A12-1C-2700-2-2**

**MAINTENANCE MANUAL  
COMMERCIAL-OFF-THE-SHELF (COTS)**

**FOR  
MINE RESISTANT AMBUSH PROTECTED  
ALL TERRAIN VEHICLE (M-ATV)**

**M1240  
NSN: 2355-01-575-9632 (EIC 1UT)**

**M1240A1  
NSN: 2355-01-596-1330 (EIC 1ZW)**

**M1245  
NSN: 2355-01-586-8070 (EIC 1VE)**

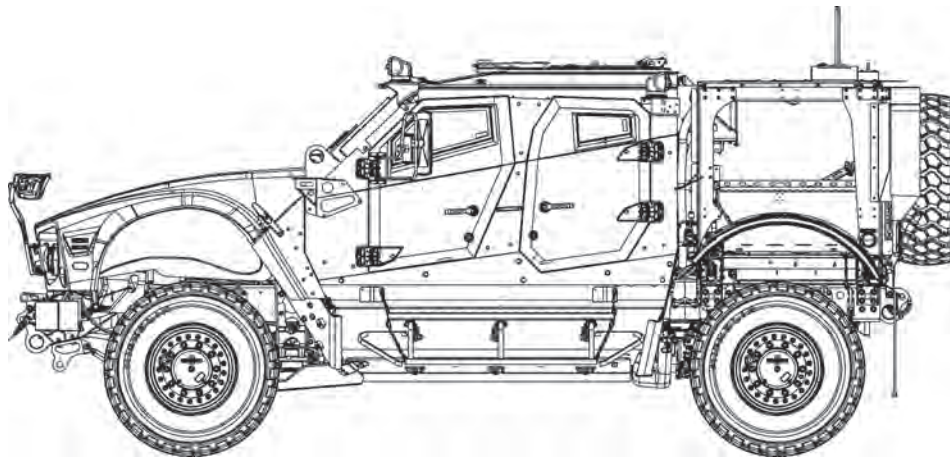

\*This manual supersedes TM 9-2355-335-23-2, dated 15 June 2011.

**COPYRIGHT RELEASE STATEMENT:** Oshkosh Corporation states this Commercial Off the Shelf (COTS) manual dated 28 February 2013 is free from copyright restrictions. The Government may edit, reprint, and distribute information in this manual as required.

**DISTRIBUTION STATEMENT C:** Distribution authorized to US Government agencies and their contractors; proprietary information. This publication is Administrative-Operational Use required for administrative and operational purposes, as determined on 02 October 2009. Other requests for this document shall be referred to U.S. Army TACOM Life Cycle Management Command, PM-MRAP, ATTN: AMSTA-LCC-MM/TECH PUBS, 6501 E. 11 Mile Road, Warren, MI 48397-5000.

**DESTRUCTION NOTICE:** Destroy by any method that will prevent disclosure of contents or reconstruction of the document.

**HEADQUARTERS, DEPARTMENT OF THE ARMY**

**28 FEBRUARY 2013**



---

**SAFETY SUMMARY**

---

This list summarizes critical warnings and cautions in this technical manual. They are listed here for summary purposes and to represent their significance. Study these warnings and cautions carefully. They can save your life and the lives of personnel you work with, as well as preventing damage to equipment. If there is any doubt or questions, contact your Supervisor.

**WARNING**

**395/85R20 tire weighs 380 lbs (172. kg). Do not lift or move 395/85R20 tire without the aid of two assistants and lifting device. Failure to comply may result in injury or death to personnel.**

**WARNING**

**5th seat weighs 80 lbs (37 kg). Do not attempt to remove 5th seat from vehicle without the aid of an assistant and lifting device. Failure to comply may result in injury or death to personnel.**

**WARNING**

**Adequate ventilation shall be provided while using solvents and cleaners. Prolonged breathing of vapors should be avoided. Do not use near heat or open flame. Avoid prolonged contact with skin. Use of rubber gloves conforming to FED SPEC ZZ-G-281, face shield conforming to L-F-36, and other protective equipment are required according to OSHA Standard. Failure to comply may result in injury or death to personnel.**

**WARNING**

**Adhesives, solvents, and sealing compounds can burn easily, can give off harmful vapors, and are harmful to skin and clothing. To avoid injury or death, keep away from open fire and use in well-ventilated area. If adhesive, solvent, or sealing compound gets on skin or clothing, wash immediately with soap and water. Failure to comply may result in injury or death to personnel.**

**WARNING**

**Air compressor weighs 50 lbs (23 kg). Do not lift or move air compressor without the aid of an assistant. Failure to comply may result in injury or death to personnel.**

**WARNING**

**Air lines may be under extreme pressure. Ensure all personnel wear protective goggles when working around compressed air. Failure to comply may result in injury or death to personnel.**

**WARNING**

**Air lines under pressure will move violently when removed. Ensure air system is drained prior to removing air lines. Failure to comply may result in injury or death to personnel.**

**WARNING**

Air system must be drained prior to removing air dryer filter. Failure to comply may result in injury or death to personnel.

**WARNING**

Air system must be drained prior to removing air system components. Failure to comply may result in injury or death to personnel.

**WARNING**

All batteries must be disconnected prior to performing battery isolator removal. Failure to comply may result in injury or death to personnel.

**WARNING**

Allow heat shrink tubing to cool before handling. Failure to comply may result in injury to personnel.

**WARNING**

Allow solder to cool before handling. Failure to comply may result in injury to personnel.

**WARNING**

Alternator weighs 115 lbs (52 kg). Do not lift or move alternator without the aid of an assistant and lifting device. Failure to comply may result in injury or death to personnel.

**WARNING**

Always wear heavy leather gloves when handling winch cable. Never let cable run through hands. Broken wires will cause injury to personnel.

**WARNING**

Antenna platform weighs 200 lbs (91 kg). Do not attempt to lift or move antenna platform without the aid of an assistant and a lifting device. Failure to comply may result in injury or death to personnel.

**WARNING**

Anti-corrosion compound is toxic. Use only in well-ventilated area. Use NIOSH/MSHA-approved respirator with dual organic vapor/mist and particulate cartridge. Do not get in eyes; wear chemical safety goggles and full face shield when using. Avoid contact with skin and wear rubber or plastic, solvent-resistant gloves. In case of contact, remove contaminated clothing and immediately wash area with soap and water. If eyes are contacted, flush eyes with large amounts of water for at least 15 minutes and get immediate medical attention. If swallowed, do not induce vomiting; contact a physician immediately. Failure to comply may result in injury or death to personnel.



**WARNING**

Avoid electrolyte contact with skin and eyes. Failure to comply may result in injury or death to personnel.

**WARNING**

Ballistic glass may become very hot when exposed to sun or when in a hot environment. Avoid contacting hot ballistic glass with hands or skin. Failure to comply may result in injury to personnel.

**WARNING**

Battery acid is harmful to skin and eyes. Always wear safety goggles, acid-proof gloves, and a rubber apron when performing battery maintenance. Failure to comply may result in injury or death to personnel.

**WARNING**

Be careful not to short out battery terminal. Do not smoke or use open flame near batteries. Batteries may explode from spark. Failure to comply may result in injury or death to personnel.

**WARNING**

Brake drum weighs 116 lbs (53 kg). Do not lift or move brake drum without the aid of an assistant and a lifting device. Failure to comply may result in injury to personnel.

**WARNING**

Brake shoes and inside surface of brake drum may be coated with dust. Breathing dust may be harmful to your health. Do not use compressed air to clean brake drum. Using the wet method, spray down brake drum and brake shoes with water to remove dust residue. Failure to comply may result in injury or death to personnel.

**WARNING**

Brake spring is under extreme tension and can act as projectile when being installed. Ensure all personnel wear protective goggles. Failure to comply may result in injury to personnel.

**WARNING**

Cable can become frayed or contain broken wires. Wear heavy leather-palmed gloves when handling cable. Never let moving cable slide through hands, even when wearing gloves. Failure to comply may result in injury or death to personnel.

**WARNING**

Cable ties must be removed from shoulder belts or shoulder belts will not function properly. Failure to comply may result in injury or death to personnel.

**WARNING**

Capsule doors weigh 276 to 298 lbs (125 to 135 kg). Do not attempt to lift or move capsule doors without the aid of an assistant and lifting device. Failure to comply may result in injury or death to personnel.

**WARNING**

Capsule doors weigh 280 lbs (127 kg). Do not attempt to lift or move capsule doors without the aid of an assistant and lifting device. Failure to comply may result in injury or death to personnel.

**WARNING**

Capsule interior fire suppression system activation rapidly release highly pressurized gas. Never put fingers inside of or look directly into fire suppression cylinder. Do not leave equipment or other objects near the cylinder. Failure to comply may result in injury to personnel.

**WARNING**

Capsule interior fire suppression system uses optical fire detectors. Do not smoke or have open flame inside the capsule, as fire suppression system may activate. Failure to comply may result in injury to personnel.

**WARNING**

Capsule windshields weigh 210 lbs (95 kg). Do not attempt to lift or move capsule windshield without the aid of an assistant and lifting device. Failure to comply may result in injury or death to personnel.

**WARNING**

Cargo deck litter door frame weighs 55 lbs (25 kg). Do not move cargo deck litter door frame without the aid of an assistant. Failure to comply may result in injury to personnel.

**WARNING**

Cargo deck quick lock floor weighs approximately 80 lbs (36 kg). Do not lift or move hood without the aid of an assistant and a lifting device. Failure to comply may result in injury or death to personnel.

**WARNING**

Cargo deck side wall and dyneema panels weigh 90 lbs (41 kg). Do not move or lift side wall or dyneema panel without the aid of an assistant. Failure to comply may result in injury to personnel.

**WARNING**

Cargo deck weighs 1950 lbs (885 kg). Do not lift or move cargo body without the aid of an assistant and a lifting device. Failure to comply may result in injury or death to personnel.

**WARNING**

Cargo deck weighs 660 lbs (300 kg). Do not attempt to lift or move cargo deck without the aid of an assistant and a lifting device. Failure to comply may result in injury or death to personnel.

**WARNING**

Center belly deflector panel weighs 420 lbs (191 kg). Do not attempt to lift or move center belly deflector panel without the aid of an assistant and lifting device. Failure to comply may result in injury or death to personnel.

**WARNING**

Center lifting fixture weighs 100 lbs (45 Kg). Do not attempt to lift or move center lifting fixture without the aid of an assistant and a lifting device. Failure to comply may result in injury or death to personnel.

**WARNING**

Clean up all fluid spills to prevent slip and fire hazards. Dispose of material in accordance with local hazardous waste disposal procedures. Failure to comply may result in injury to personnel and damage to the environment.

**WARNING**

Cloths or rags saturated with solvent cleaning compound must be disposed of IAW authorized facility's procedures. Failure to comply may result in injury to personnel.

**WARNING**

Coil spring is under extreme spring tension and can act as a projectile when installed. Raise the lower control arm very slowly to keep spring from releasing uncontrollably. Failure to comply may result in injury or death to personnel.

**WARNING**

Coil spring weighs 110 lbs (50 kg). Do not lift or move coil spring without the aid of an assistant and lifting device. Failure to comply may result in injury or death to personnel.

**WARNING**

Combined weight of steering gear tray and steering gears is 319 lbs (145 kg). Do not lift or move steering gear tray and steering gears without the aid of an assistant and a lifting device. Failure to comply may result in injury or death to personnel.

**WARNING**

Compressed air used for cleaning purposes will not exceed 30 psi (207 kPa). Use only with effective chip guarding and personnel protective equipment (goggles/shield, gloves, etc). Failure to comply may result in injury to personnel.

**WARNING**

Connector lubricant is harmful to skin. Prolonged or repeated contact with skin or contact with eyes may cause irritation. If eyes are contacted, rinse thoroughly and contact physician if irritation persists. If skin is contacted, wash thoroughly with soap and water. Failure to comply may result in injury or death to personnel.

**WARNING**

Coolant may splash during hose removal. Ensure personnel wear protective goggles. Failure to comply may result in injury to personnel.

**WARNING**

Cooling system assembly weighs approximately 400 lbs (182 kg). Do not attempt to lift or move cooling system assembly without the aid of an assistant and a lifting device. Failure to comply may result in injury or death to personnel.

**WARNING**

Crossmember weighs 113 lbs (51 kg). Do not attempt to lift or move crossmember without the aid of an assistant and a lifting device. Failure to comply may result in injury or death to personnel.

**WARNING**

Depending on GFE on CVRJ box shelf, weight may vary. A lifting device may be required to aid in installation. Failure to comply may result in injury or death to personnel.

**WARNING**

Differential assembly weighs 250 lbs (113 kg). Do not lift differential assembly without the aid of an assistant and a lifting device. Failure to comply may result in injury or death to personnel.

**WARNING**

Disconnecting the rear capsule door hardware allows the doors to move freely. Keep hands away from pinch point areas of the rear capsule door assembly, hands and fingers could get crushed or pinched. Failure to comply may result in injury to personnel.

**WARNING**

Do not adjust front poppet screw beyond flush with steering gear cover. Failure to comply may result in damage to equipment or injury to personnel.

**WARNING**

Do not attempt to pressure or leak test refrigerant R-134A air conditioning systems with compressed air. Combustible mixtures of air and R-134A may form, resulting in a fire or explosion. Failure to comply may result in injury or death to personnel.

**WARNING**

Do not exceed 600 lbs (272.4 kg) weight capacity of winch assembly. Failure to comply may result in injury or death to personnel.

**WARNING**

Do not lower jack completely until tightening sequence is complete. Failure to comply may result in injury or death to personnel.

**WARNING**

Do not place hand or fingers between bracket and frame when removing mounting cushions. Failure to comply may result in injury or death to personnel.

**WARNING**

Do not remove clamp from brake chamber. Failure to comply may result in injury or death to personnel and damage to equipment.

**WARNING**

Do not remove nut until lower control arm is separated from knuckle. Failure to comply may result in injury or death to personnel.

**WARNING**

Do not smoke, have open flame, or cause sparks near batteries. Batteries may explode. Failure to comply may result in injury or death to personnel.

**WARNING**

Do not use improper cleaning methods or unauthorized cleaning solvents. Failure to comply may result in injury or death to personnel and damage to equipment.

**WARNING**

Do not wear watches or other jewelry when working on winch cable. Jewelry can catch on equipment. Failure to comply may result in injury to personnel.

**WARNING**

Drilling and grinding operations are hazardous to the eyes. Eye protection is required. Failure to comply may result in injury to personnel.

**WARNING**

Driver side belly deflector panel weighs 364 lbs (165 kg). Do not attempt to lift or move driver side belly deflector panel without the aid of an assistant and lifting device. Failure to comply may result in injury or death to personnel.

**WARNING**

Driver side door assembly weighs 185 lbs (84 kg) and passenger side door assembly weighs 170 lbs (77 kg). Do not attempt to lift or move assemblies without the aid of an assistant and a lifting device. Failure to comply may result in injury or death to personnel.

**WARNING**

During normal vehicle operation, cooling system can become very hot. Allow cooling system to cool prior to servicing cooling system. Failure to comply may result in injury or death to personnel.

**WARNING**

During normal vehicle operation, cooling system components can become very hot. Allow cooling system to cool prior to servicing. Wear face shield and use extreme care when removing surge tank cap. Sudden release of pressure can cause a steam flash. Slowly loosen surge tank cap to the first stop to relieve pressure before removing surge tank cap completely. Use a clean, thick waste cloth or like material to remove surge tank cap. Avoid using gloves. If hot coolant soaks through gloves, personnel could be burned. Failure to comply may result in injury or death to personnel.

**WARNING**

During vehicle operation exhaust system can become very hot. Do not touch exhaust system components with bare hands, or allow your body to come in contact with exhaust system components. Failure to comply may result in injury to personnel.

**WARNING**

Engine belly deflector panel weighs 60 lbs (27 kg). Do not attempt to lift or move engine belly deflector panel without the aid of an assistant and lifting device. Failure to comply may result in injury or death to personnel.

**WARNING**

Engine components become hot during normal operation. Allow engine to cool completely prior to performing this task. Failure to comply may result in injury or death to personnel.

**WARNING**

Engine must be shut down prior to working on hydraulic components to drop hydraulic pressure to zero. Potential trapped pressure may be present. Loosen couplings slowly to relieve any remaining hydraulic pressure. Failure to comply may result in injury or death to personnel.

**WARNING**

Ensure air system is drained prior to working on air system components. Failure to comply may result in injury or death to personnel.

**WARNING**

Ensure all test equipment is properly connected. Failure to comply may result in injury or death to personnel.

**WARNING**

Ensure batteries and undercarriage controller connector are disconnected prior to replacing sensor lines. Failure to comply may result in injury or death to personnel.

**WARNING**

Ensure batteries are disconnected when performing maintenance on or near batteries or electrical systems. Always remove negative battery terminals first. When reconnecting, always connect negative terminals last to avoid arcing or sparks that could cause an explosion.

**WARNING**

Ensure battery disconnect switch is in OFF position. Failure to comply may result in injury or death to personnel.

**WARNING**

Ensure blue caps are removed from aerosol generators after installation. If blue caps remain installed, aerosol generators may fail to discharge. Failure to comply may result in injury or death to personnel.

**WARNING**

Ensure engine oil and filter are cool prior to removal. Failure to comply may result in injury to personnel.

**WARNING**

Ensure fire suppression cylinder valves are in OFF position. Failure to comply may result in discharge of cylinder or injury to personnel.

**WARNING**

Ensure fire suppression system cylinders are in the OFF position first, then relieve pressure in sensor line system prior to replacing any sensor lines, or accidental discharge may occur. Failure to comply may result in injury or death to personnel.

**WARNING**

Ensure personnel wear protective goggles when removing air lines. Failure to comply may result in injury or death to personnel.

**WARNING**

Ensure pressure indication on gauge for sensor line system is in green arc prior to moving valve on fire suppression system cylinders to ON position. Fire suppression system cylinders could discharge when valve is moved to ON position if sensor line pressure is not in the green arc on pressure gauge. Failure to comply may result in injury or death to personnel.

**WARNING**

Ensure pressure is 0 psi in sensor line system prior to sensor line replacement. Failure to comply may result in injury to personnel.

**WARNING**

Ensure skid plate is supported during removal to avoid pinching and binding. Failure to comply may result in injury or death to personnel.

**WARNING**

Ensure transmission oil is cool prior to draining transmission oil. Failure to comply may result in injury to personnel.

**WARNING**

Ensure valve knob on inflation tool is fully closed (OUT) before proceeding. Failure to comply may result in injury or death to personnel.

**WARNING**

Ensure valve knob on inflation tool is fully closed (turned out counterclockwise) prior to installation. Failure to comply may result in injury or death to personnel.

**WARNING**

Ensure vehicle battery disconnect switch is in OFF position before inspecting fire suppression system. Failure to comply may result in injury or death to personnel.

**WARNING**

Exhaust pipe may be hot. Do not touch hot exhaust pipe. Failure to comply may result in injury to personnel.

**WARNING**

Eye shields must be worn when cleaning with a wire brush. Flying rust and metal particles may be present. Failure to comply may result in injury or death to personnel.

**WARNING**

Fire extinguishers should be placed nearby when using solvent cleaning compound. Failure to comply may result in injury or death to personnel.

**WARNING**

Front differential housing weighs 250 lbs (113 kg) and rear differential housing weighs 280 lbs (127 kg). Do not lift or move differential housing without the aid of an assistant and a lifting device. Failure to comply may result in injury or death to personnel.

**WARNING**

Front seat weighs 112 lbs (51 kg). Do not attempt to move seat without the aid of an assistant and a suitable lifting device. Failure to comply may result in injury or death to personnel.

**WARNING**

Front windows weigh 122 lbs (55 kg). Do not attempt to lift or move front windows without the aid of an assistant and a lifting device. Failure to comply may result in injury or death to personnel.



**WARNING**

Fuel is flammable and can explode. Keep fuel away from open flame and keep fire extinguisher within easy reach when working with fuel. Do not work on fuel system when engine is hot. Fuel can be ignited by hot engine. Smoking is prohibited while working with fuel. Failure to comply may result in injury or death to personnel.

**WARNING**

Fuel is flammable and can explode. Keep fuel away from open flame and keep fire extinguisher within easy reach when working with fuel. Do not work on fuel system when engine is hot. Fuel can be ignited by hot engine. Smoking is prohibited while working with fuel. Failure to comply may result in injury or death to personnel.

**WARNING**

Fuel tank is awkward. Do not attempt to lift or move fuel tank without the aid of an assistant and/or lifting device. Failure to comply may result in injury or death to personnel.

**WARNING**

Halfshaft weighs 50 lbs (23 kg). Do not lift or move halfshaft without the aid of an assistant. Failure to comply may result in injury or death to personnel.

**WARNING**

Hood assembly weighs 158 lbs (72 kg). Do not lift or move hood assembly without the aid of an assistant and a lifting device. Failure to comply may result in injury or death to personnel.

**WARNING**

Hub assembly weighs 60 lbs (27 kg). Do not lift or move hub assembly without the aid of an assistant. Failure to comply may result in injury or death to personnel.

**WARNING**

HVAC assembly and HVAC tray weighs 60 lbs (27.2 kg). Do not move or lift HVAC assembly and HVAC tray without the aid of an assistant. Failure to comply may result in injury or death to personnel.

**WARNING**

Hydraulic jack is intended only for lifting vehicle, not for supporting vehicle while performing maintenance. Do not get under vehicle after vehicle has been raised, unless vehicle is properly supported with jack stands. Failure to comply may result in injury or death to personnel.

**WARNING**

If 395/85/20 tire was installed, configure vehicle in accordance with spare tire limp home procedure (TM 9-2355-335-10) prior to operating vehicle. Failure to comply may result in injury or death to personnel.

**WARNING**

If measurement does not meet acceptable minimum or maximum tolerance, pitman arm and steering gear output shaft must be replaced. Failure to take measurement or replace worn part could result in pitman arm becoming loose, causing injury or death to personnel.

**WARNING**

If pitman arm is not tightened to proper specifications, pitman arm could work loose or lose its attachment, causing an accident. If pitman arm is found loose, replace pitman arm and steering gear output shaft. Never weld pitman arm or steering gear output shaft. Failure to comply may result in injury or death to personnel.

**WARNING**

If welding, brazing, grinding, or open flame operations have been performed, any components subject to these operations must be allowed to cool before enabling automatic fire suppression system. Failure to comply may result in injury to personnel.

**WARNING**

Installing rear capsule door locking assembly allows the doors to move freely. Keep hands away from pinch point areas of the rear capsule door assembly, hands and fingers could get crushed or pinched. Failure to comply may result in injury to personnel.

**WARNING**

Keep cargo deck rear doors closed and locked at all times during spare tire stow/unstow operation. Failure to comply may result in injury to personnel.

**WARNING**

Keep hands and fingers away from pinch point areas of cargo quick lock floor. Failure to comply may result in injury to personnel.

**WARNING**

Keep hands and fingers away from pinch point areas of litter doors. Hands and fingers could get pinched or crushed. Failure to comply may result in injury to personnel.

**WARNING**

Keep hands and fingers away from pinch point areas of the cargo deck assembly. Hands and fingers could get crushed. Failure to comply may result in injury to personnel.

**WARNING**

Keep hands and fingers away from winch assembly when operating winch. Failure to comply may result in injury or death to personnel.

**WARNING**

Keep hands away from pinch point area of the assembly when swinging spare tire assembly. Hands and fingers could get crushed. Failure to comply may result in injury to personnel.

**WARNING**

Keep hands away from pinch point areas of the tire carrier assembly. Hands and fingers could get crushed. Failure to comply may result in injury to personnel.

**WARNING**

Keep out from under spare tire when lowering and raising spare tire. Spare tire can slip or fall. Failure to comply may result in injury or death to personnel.

**WARNING**

Ladder panel weighs approximately 800 lbs (363 kg). Do not attempt to lift or move ladder panel without the aid of an assistant and a lifting device. Failure to comply may result in injury or death to personnel.

**WARNING**

Lead-acid batteries contain sulfuric acid, which can cause severe burns. Avoid contact with skin, eyes, or clothing. Wear safety goggles and gloves. If battery electrolyte is spilled, take immediate action to stop its corrosive (burning) effects. If battery acid is spilled on clothing or vehicle, wash immediately with cold water. Neutralize with baking soda or household ammonia solution. If battery acid comes in contact with skin, flush with cold water to remove acid. If eyes are contacted, flush with cold water for at least 15 minutes. Seek immediate medical attention. If swallowed, drink large amounts of water or milk, follow with milk of magnesia, beaten egg, or vegetable oil. Seek immediate medical attention. Failure to comply may result in injury or death to personnel.

**WARNING**

Litter door and dyneema panel assembly weigh 142 lbs (65 kg). Do not move or lift litter door or dyneema panel without the aid of an assistant and a lifting device. Failure to comply may result in injury to personnel.

**WARNING**

Loosening of the crossbrace hardware is necessary to prevent binding of the gunner's platform while height adjustment is being made. Ensure crossbrace hardware is tight prior to using gunner's platform. Failure to comply may result in injury or death to personnel.

**WARNING**

Lower control arm weighs 90 lbs (41 kg). Do not attempt to lift or move upper control arm without the aid of an assistant and lifting device. Failure to comply may result in injury or death to personnel.

**WARNING**

M-ATV is equipped with a capsule interior automatic fire suppression system. Before performing any welding, brazing, grinding, or using open flame in capsule, batteries must be disconnected. In addition, the maintenance circuit breaker located to the right of the main circuit breaker in the dash must be pulled out to prevent accidental activation of automatic fire suppression system in the capsule. System components must also be covered. Failure to comply may result in injury to personnel.

**WARNING**

M-ATV is equipped with an engine compartment fire suppression system. Before performing any welding, brazing, grinding operation, or using open flame in engine compartment, batteries must be disconnected. In addition, the automatic fire suppression system for the engine compartment must be disabled to prevent accidental activation of automatic fire suppression system. System components must also be covered. Failure to comply may result in injury to personnel.

**WARNING**

M-ATV is equipped with an engine compartment fire suppression system. Before performing any welding, brazing, grinding operation, or using open flame in engine compartment, batteries must be disconnected. In addition, the automatic fire suppression system for the engine compartment must be disabled to prevent accidental activation of automatic fire suppression system. System components must also be covered. Failure to comply may result in injury to personnel. If welding, brazing, grinding, or open flame operations have been performed, any components subject to these operations must be allowed to cool before enabling automatic fire suppression system. Failure to comply may result in injury to personnel.

**WARNING**

M-ATV is equipped with an undercarriage fire suppression system designed to extinguish fires in all wheel wells and in fuel tank area. Before performing any welding, brazing, grinding operation, or using open flame in or around the wheel well/fuel tank areas, batteries must be disconnected. In addition, the automatic fire suppression system for the undercarriage must be disabled to prevent accidental activation of automatic fire suppression system system. Care must be taken to prevent damage to any of the fire suppression sensor lines which, if damaged, may trigger automatic fire suppression system upon system being enabled. Undercarriage fire suppression system is triggered by loss of pressure in sensor lines. Failure to comply may result in injury to personnel.

**WARNING**

Never apply load on winch with cable fully extended. Keep at least three full turns of cable on the reel. Failure to comply may result in injury or death to personnel.

**WARNING**

Never use fuel to clean parts. Fuel is highly flammable. Fuel may ignite during cleaning. Failure to comply may result in injury or death to personnel.

**WARNING**

Never use open flame to apply heat to heat shrink tubing. Heat shrinking tubing may catch fire using open flame. Failure to comply may result in injury to personnel.

**WARNING**

Nitrogen lines under pressure will move violently when removed. Ensure nitrogen supply is shut off prior to removing air lines. Failure to comply may result in injury or death to personnel.

**WARNING**

On direct contact, uncured silicone sealant irritates eyes. In case of contact, flush eyes with water and seek medical attention. Avoid prolonged contact with skin. Failure to comply may result in injury or death to personnel.

**WARNING**

Once tab lock retainer is locked into place, do not retighten. Constant retightening of retainer could cause pitman arm to loosen or retainer to fail, causing an accident at a later date. Failure to comply may result in injury or death to personnel.

**WARNING**

Once top screws are removed from rear seat mount, the seat will pivot forward. Do not sit in seat after screws are removed. Failure to comply may result in injury or death to personnel.

**WARNING**

Panel assemblies for cargo body weigh 90 lbs (41 kg). Do not attempt to lift or move assemblies without the aid of an assistant and a lifting device. Failure to comply may result in injury or death to personnel.

**WARNING**

Passenger side belly deflector panel weighs 353 lbs (160 kg). Do not attempt to lift or move passenger side belly deflector panel without the aid of an assistant and lifting device. Failure to comply may result in injury or death to personnel.

**WARNING**

Pitman arm will be extremely tight. Do not pound on pitman arm or apply any source of heat, as damage to pitman arm or output shaft can cause an accident at a later date. Failure to comply may result in injury or death to personnel.

**WARNING**

Place a jackstand on each side of lifting device centered on ladder panel in case of transmission jack failure. Failure to comply may result in injury or death to personnel.

**WARNING**

Powertrain weighs 2,300 lbs (1 044 kg). Do not attempt to lift or move powertrain without the aid of two assistants and lifting device. Failure to comply may result in injury or death to personnel.

**WARNING**

Pressure wash area to remove discharged fire suppression chemicals prior to maintenance or service. Ensure fire suppression cylinder valves are in OFF position. Failure to comply may result in discharge of cylinder or injury to personnel.

**WARNING**

Pressure wash area to remove discharged fire suppression chemicals prior to maintenance or service. Ensure batteries are disconnected. Failure to comply may result in discharge of cylinder or injury to personnel.

**WARNING**

Primary steering gear weighs 75 lbs (34 kg). Do not lift or move primary steering gear without the aid of an assistant. Failure to comply may result in injury to personnel.

**WARNING**

Prolonged contact with lubricating oil may cause skin rash. Immediately wash skin and clothing that come in contact with lubricating oil and remove saturated clothing. Keep area well-ventilated to keep fumes at a minimum. Failure to comply may result in injury or death to personnel.

**WARNING**

Propeller shaft is awkward. Do not lift or move propeller shaft without the aid of an assistant and/or a lifting device. Failure to comply may result in injury or death to personnel.

**WARNING**

Propeller shaft weighs 60 lbs (27 kg). Do not lift or move propeller shaft without the aid of an assistant and lifting device. Failure to comply may result in injury or death to personnel.

**WARNING**

Propeller shaft weighs 88 lbs (40 kg). Do not lift or move propeller shaft without the aid of an assistant. Failure to comply may result in injury or death to personnel.

**WARNING**

Push bumper is 310 lbs (140 kg). Do not attempt to lift or move push bumper without aid of an assistant and lifting device. Failure to comply may result in injury or death to personnel.

**WARNING**

Radiator and transmission oil cooler weigh 65 lbs (29 kg). Do not lift or move radiator and transmission oil cooler without the aid of an assistant. Failure to comply may result in injury or death to personnel.

**WARNING**

Rear crossmember weights 110 lbs (50 kg). Do not attempt to lift or move rear crossmember without the aid of an assistant and lifting device. Failure to comply may result in injury or death to personnel.

**WARNING**

Rear seat weighs 83 lbs (38 kg). Do not attempt to move seat without the aid of an assistant and suitable lifting device. Failure to comply may result in injury or death to personnel.

**WARNING**

Rear wall and dyneema panels weigh 90 lbs (41 kg). Do not move or lift rear wall or dyneema panel without the aid of an assistant. Failure to comply may result in injury to personnel.

**WARNING**

Rear wall assemblies for cargo deck weigh 90 lbs (41 kg). Do not attempt to lift or move assemblies without the aid of an assistant. Failure to comply may result in injury or death to personnel.

**WARNING**

Rear windows weigh 46 lbs (21 kg). Do not attempt to lift or move rear window without the aid of an assistant. Failure to comply may result in injury or death to personnel.

**WARNING**

Refrigerant R-134a air conditioning systems should not be pressured-tested or leak-tested with compressed air. Combustible mixtures of air and R-134a may form. Failure to comply may result in injury or death to personnel.

**WARNING**

Remove all jewelry, such as rings, dog tags, bracelets, etc. If jewelry contacts battery terminal or positive electrical circuit, a direct short may result in instant heating of tools, injury or death to personnel, or damage to equipment.

**WARNING**

Removing rear capsule door locking assembly allows the doors to move freely. Keep hands away from pinch point areas of the rear capsule door assembly, hands and fingers could get crushed or pinched. Failure to comply may result in injury to personnel.

**WARNING**

Secondary steering gear weighs 70 lbs (32 kg). Do not lift or move secondary steering gear without the aid of an assistant. Failure to comply may result in injury to personnel.

**WARNING**

Secure transfer case to transmission jack with ratchet strap. Failure to comply may result in injury or death to personnel.

**WARNING**

Shock absorbers are filled with high pressure gas. Service shock absorbers with adequate ventilation. Do not use or store cylinder near heat or open flame. Cylinder temperature should not exceed 125°F (52°C). Use with equipment rated for cylinder pressure. Open valve slowly. Close valve after each use and in storage. Use in accordance with Material Safety Data Sheet for Nitrogen. If inhaled, move to area with fresh air. Failure to comply may result in injury or death to personnel.

**WARNING**

Side lifting fixture weighs 95 lbs (43 Kg). Do not attempt to lift or move side lifting fixture without the aid of an assistant and a lifting device. Failure to comply may result in injury of death to personnel.

**WARNING**

Skid plate weighs 53 lbs (24 kg). Do not lift or move skid plate without the aid of an assistant. Failure to comply may result in injury or death to personnel.

**WARNING**

Solvent cleaning compound MIL-PRF-680 Type II and III may be irritating to the eyes and skin. Use protective gloves and goggles. Use in well-ventilated areas. Use respirator as needed. Accidental ingestion can cause irritation of digestive tract and respiratory tract, may cause lung and central nervous system damage. Can be fatal if swallowed. Inhalation of high/massive concentrations can cause coma or be fatal. First aid for ingestion: do not induce vomiting. Seek immediate medical attention. First aid for skin contact: remove contaminated clothing. Wash skin thoroughly with soap and water. If symptoms persist, seek medical attention. First aid for eye contact: flush with water for 15 minutes or until irritation subsides. If symptoms persist, seek medical attention. First aid for inhalation: move to fresh air. If not breathing, provide artificial respiration. If symptoms persist, seek medical attention. Keep away from open flames and other flames and other sources of ignition. Failure to follow this warning may result in injury or death to personnel.

**WARNING**

Solvents used with a spray gun must be used in a spray booth with filter. Face shield must be used by personnel operating spray gun. Failure to comply may result in injury to personnel.



**WARNING**

Spare tire weighs 380 lbs (172. kg). Do not attempt to lift or move spare tire without the aid of two assistants and a lifting device. Failure to comply may result in injury or death to personnel.

**WARNING**

SPARK bar weighs 97 lbs (44 kg). Do not lift or move SPARK bar without the aid of an assistant and lifting device. Failure to comply may result in injury or death to personnel.

**WARNING**

Spindle may become loose when removing spider. Support spindle when removing spider. Failure to comply may result in injury to personnel.

**WARNING**

Spring brake chamber contains a spring under great pressure. Never work directly behind spring brake chamber. Failure to comply may result in injury or death to personnel and damage to equipment.

**WARNING**

Spring may come free from vehicle while lowering jack. Spring may have to be rotated to aid in removal. Failure to comply may result in injury or death to personnel.

**WARNING**

Springs and retaining rings are under extreme tension and can act as projectiles when being installed. Ensure all personnel wear protective goggles. Failure to comply may result in injury to personnel.

**WARNING**

Stand clear of vehicle while wheels are turned. Failure to comply may result in injury or death to personnel.

**WARNING**

Standard M1240A1 tire assembly weighs 600 lbs (272.4 kg). Do not attempt to lift or move tire assembly without the aid of an assistant and a suitable lifting device. Failure to comply may result in injury or death to personnel.

**WARNING**

Starter weighs 50 lbs (23kg). Do not lift or move starter without the aid of an assistant. Failure to comply may result in injury to personnel.

**WARNING**

Steam cleaning creates hazardous noise levels and severe burn potential. Eye, skin, and ear protection are required. Failure to comply may result in injury to personnel.

**WARNING**

The flashpoint for Type II solvent cleaning compound is 141 to 198°F (61 to 92°C) and Type III is 200 to 241°F (93 to 116°C).

**WARNING**

Tip of removal tool is very sharp. Use caution when using tool. Failure to comply may result in injury to personnel.4

**WARNING**

To prevent arcing, do not allow tools to contact batteries or other battery terminals. Failure to comply may result in injury or death to personnel.

**WARNING**

Transfer case weighs 312 lbs (142 kg). Do not lift or move transfer case without the aid of an assistant and lifting device. Failure to comply may result in injury or death to personnel.

**WARNING**

Transmission holding bracket weighs 93 lbs (42 kg). Do not attempt to lift or move transmission holding bracket without the aid of an assistant and a lifting device. Failure to comply may result in injury or death to personnel.

**WARNING**

Transmission weighs 700 lbs (318 kg). Do not lift or move transmission without the aid of an assistant and lifting device. Failure to comply may result in injury or death to personnel.

**WARNING**

Turn cap on coolant reservoir bottle one half turn and stop prior to removing cap completely. Pressure must be relieved from coolant reservoir bottle prior to removal of cap or injury to personnel may occur.

**WARNING**

Underbody improvement panel weighs 1,000 lbs (454 kg). Do not attempt to lift or move center deflector panel without the aid of an assistant and lifting device. Failure to comply may result in injury or death to personnel.

**WARNING**

Upon removal of terminal clamps, avoid accidental contact between terminal clamps and battery terminals. This will prevent accidental shorting, arcing, or sparks. Secure terminal clamps, cables, and wires away from battery terminals with cable ties as required. Failure to comply may result in injury or death to personnel.

**WARNING**

Upon removal of wires and cables, ensure no contact is made with battery terminals or other wires and cables. Secure wires and cables away from battery terminals and other wires and cables as required. Failure to comply may result in injury or death to personnel or damage to equipment.

**WARNING**

Upper control arm weighs 80 lbs (36 kg). Do not attempt to lift or move upper control arm without the aid of an assistant and lifting device. Failure to comply may result in injury or death to personnel.

**WARNING**

Use care to prevent refrigerant from touching skin or eyes. Liquid refrigerant, when exposed to air, quickly evaporates and will freeze skin or eye tissues. Failure to comply may result in injury or death to personnel.

**WARNING**

Use extreme care not to short out battery terminals. Remove all jewelry such as rings, ID tags, bracelets, etc. prior to working on or around vehicle. Jewelry and tools can catch on equipment, contact positive electrical circuits, and cause severe burns or electrical shock. Failure to comply may result in injury or death to personnel.

**WARNING**

Vehicle must not be driven with brake chambers caged. Caging brakes renders brakes inoperative. Failure to comply may result in injury or death to personnel.

**WARNING**

Wear proper eye protection and nonleather gloves when servicing air conditioner. Failure to comply may result in injury or death to personnel.

**WARNING**

Wear proper eye protection and use care when removing or installing springs, retaining rings, and snap rings. Springs, retaining rings, and snap rings are under spring tension and can act as projectiles when released. Spring must be compressed during assembly. Failure to comply may result in injury to personnel.

**WARNING**

Wear proper eye protection and use care when removing or installing springs, retaining rings, and snap rings. Springs, retaining rings, and snap rings are under spring tension and can act as projectiles when released. Valve is spring loaded. Spring must be compressed during assembly. Failure to comply may result in injury to personnel.

**WARNING**

Wheel end assembly weighs 550 lbs (249 kg). Do not remove lower and upper control arm ball joints at the same time. Failure to comply may result in injury or death to personnel.

**WARNING**

Wheel well deflector panel weighs 54 lbs (24.5 kg). Do not attempt to lift or move wheel well deflector panel without the aid of an assistant. Failure to comply may result in injury or death to personnel.

**WARNING**

Wheel well deflector panel weighs 60 lbs (27 kg). Do not attempt to lift or move wheel well deflector panel without the aid of an assistant. Failure to comply may result in injury or death to personnel.

**WARNING**

When removing air lines, loosen couplings slowly to bleed off air pressure in air lines. Ensure personnel wear protective goggles when removing air lines. Failure to comply may result in injury or death to personnel.

**WARNING**

When removing relief valves, loosen relief valves slowly to bleed off any trapped pressure that might be present. Ensure personnel wear protective goggles when removing relief valves. Failure to comply may result in injury or death to personnel.

**WARNING**

When tightening castle nut, do not loosen castle nut to install cotter pin. Continue to tighten castle nut until cotter pin can be installed. Failure to comply may result in injury or death to personnel.

**WARNING**

When using a punch and ball peen hammer, always wear safety glasses. Never use a punch that is damaged. Failure to comply may result in injury or death to personnel.

**WARNING**

While engine is running, transmission **MUST** be in N (neutral), **PARKING BRAKE** must be set and properly engaged, and wheels **MUST** be chocked. Failure to comply may result in injury or death to personnel.

**WARNING**

Winch and front crossmember are removed/installed as an assembly. Winch and front crossmember weigh 214 lbs (97 kg). Do not lift or move winch and crossmember without the aid of an assistant and a lifting device. Failure to comply may result in injury or death to personnel.

**WARNING**

Winch and winch bracket are removed as an assembly. Winch and winch bracket weigh 167 lbs (76 kg). Do not lift or move winch bracket without the aid of an assistant and/or a lifting device. Failure to comply may result in injury or death to personnel.

**WARNING**

Winch is NOT to be used for lifting or moving of persons. Failure to comply may result in injury or death to personnel.

**WARNING**

Winch is only to be used to stow/unstow spare tire. Winch is not to be used to lift other components or material. Failure to comply may result in injury or death to personnel.

**WARNING**

Winch weighs 119 lbs (54 kg). Do not lift or move winch without the aid of an assistant and a lifting device. Failure to comply may result in injury or death to personnel.

**CAUTION**

A bearing is located directly behind seal in spindle. When prying seal from spindle, do not damage bearing. Failure to comply may result in damage to equipment.

**CAUTION**

A resistance load of 175 lbs (79 kg) must be applied to wire rope to overcome internal resistance and operate winch brake properly. Turning winch handle counterclockwise will remove winch handle from drive shaft and reel will not turn. Failure to comply may result in damage to equipment.

**CAUTION**

After charging, allow charge to set 10 to 15 minutes. This allows time for the gas temperature to stabilize. Failure to comply may result in damage to equipment.

**CAUTION**

After powertrain is lifted up, front rubber mounts and washers may need to be removed for oil pan clearance. Failure to comply may result in damage to equipment.

**CAUTION**

All air cleaner element maintenance must be performed above temperatures of -10°F (-23°C). Failure to comply may result in damage to equipment.

**CAUTION**

Avoid excess removal of surface finish to adjacent area. Failure to comply may result in damage to equipment.

**CAUTION**

Blower motor cover should be reinstalled prior to HVAC assembly removal to prevent damage to HVAC internal wiring harness and /or components. Failure to comply may result in damage to equipment.

**CAUTION**

Boot damage will result if hammer is allowed to strike soft boot material. Strike only the metal boot band. Failure to comply may result in damage to equipment.

**CAUTION**

Butt splice connector sizes vary by wire diameter. To ensure secure repair, use only butt splice connector size specified for the wire being repaired. Do not modify butt splice connector to fit. Failure to comply may result in damage to equipment.

**CAUTION**

Care must be used when installing 395/85R20 tire on tire carrier. Air valve on 395/85R20 tire is inserted through top driver side slot of tire carrier. Ensure spacer is aligned properly to avoid damage to CTIS valve. Failure to comply may result in damage to equipment.

**CAUTION**

Cargo deck side wall panel must be placed on a soft, flat surface before removing dyneema panel. Failure to comply may result in damage to equipment.

**CAUTION**

Caution must be used when installing spare tire on tire carrier. Air valve on spare tire is inserted through top driver side slot of tire carrier. Failure to comply may result in damage to equipment.

**CAUTION**

Caution must be used when removing spare tire from tire carrier. Air valve on spare tire is inserted through top driver side slot of tire carrier. Failure to comply may result in damage to equipment.

**CAUTION**

Charge air cooler is cumbersome. It should be installed with the aid of an assistant. Failure to comply may result in damage to equipment.

**CAUTION**

Charge air cooler is cumbersome. It should be removed with the aid of an assistant. Failure to comply may result in damage to equipment.

**CAUTION**

Clamp belt above retractor prior to removal to prevent belt from retracting completely. Failure to comply may result in damage to equipment.

**CAUTION**

CTIS controller and CTIS dash panel must be kept together before CTIS controller connector is connected and during installation in dash. Failure to comply may result in damage to equipment.

**CAUTION**

CTIS controller and CTIS dash panel must be kept together during removal until CTIS controller connector is removed. Failure to comply may result in damage to equipment.

**CAUTION**

Cutout for retractor is not centered on mat. Align cutout in mat with cutout in gunner's platform and check for proper positioning prior to cutting. Failure to comply may result in damage to equipment.

**CAUTION**

Differential housing must be secured to transmission jack with strap. Failure to comply may result in damage to equipment.

**CAUTION**

Do not allow slip yoke to come off propeller shaft. Failure to comply may result in misalignment of propeller shaft yokes and could cause damage to equipment.

**CAUTION**

Do not apply excessive heat to heat shrink tubing. Excessive heat may cause heat shrink tubing to split or melt. Failure to comply may result in damage to equipment.

**CAUTION**

Do not bend locking tabs in pitman arm slots. Failure to comply may result in damage to equipment.

**CAUTION**

Do not clean tires, rubber hoses, or electrical components with solvent mixture. Failure to comply may result in damage to equipment.

**CAUTION**

Do not fill ball joint boot with too much grease. If boot is bulging when installed, squeeze out excess grease. Failure to comply may result in damage to equipment.

**CAUTION**

Do not hold steering wheel at full left or full right for longer than 10 seconds. Oil overheating may occur. Failure to comply may result in damage to equipment.

**CAUTION**

Do not lubricate A/C system O-rings. O-ring material is only compatible with air conditioning type lubricants. Failure to comply may result damage to equipment.

**CAUTION**

Do not open cover for farther than is required to disconnect connector. Failure to comply may result in damage to equipment.

**CAUTION**

Do not operate vehicle system with the panel high-side valve in open position. Failure to comply may result in damage to equipment.

**CAUTION**

Do not over tighten threaded insert. Failure to comply may result in damage to equipment.

**CAUTION**

Do not overcharge system. The system is fully charged with 3.5 lbs (1.59 kg) of refrigerant. Failure to comply may result in damage to equipment.

**CAUTION**

Do not overtighten clamp on heater control valve. Failure to comply may result in damage to equipment.

**CAUTION**

Do not overtighten locknuts. Failure to comply may result in damage to hood.

**CAUTION**

Do not overtighten nuts (14). Failure to comply may result in damage to receiver/dryer, loss of refrigerant, and damage to equipment.

**CAUTION**

Do not overtighten screw. Failure to comply may result in damage to equipment.

**CAUTION**

Do not permit dirt, dust, or grit to enter transmission filler tube. Thoroughly clean dipstick handle and end of filler tube. Failure to comply may result in damage to equipment.

**CAUTION**

Do not shorten springs on CTIS seals. Failure to comply may result in damage to equipment.

**CAUTION**

Do not spray cleaning solvent on the front of the dash panels or gauges. This can cause discoloration and clouding of dash panels and gauges. Failure to comply may result in damage to equipment.

**CAUTION**

Do not use a hammer to pound halfshaft into wheel end. Failure to comply may result in damage to equipment.



**CAUTION**

Do not use a removal tool to aid in removal of tie rod from pitman arm. Failure to comply may result in damage to dust cover.

**CAUTION**

Do not use a removal tool to aid in removal of toe control link from steering arm. Failure to comply may result in damage to dust cover.

**CAUTION**

Do not use a wrench to tighten oil filter housing. Failure to comply may result in damage to equipment.

**CAUTION**

Do not use an abrasive brush to wash vehicle. Failure to comply may result in damage to equipment.

**CAUTION**

Do not use cool water when cleaning hot ballistic glass. Putting cool water on hot ballistic glass may cause window to crack or delaminate. Failure to comply may result in damage to equipment.

**CAUTION**

Do not use mounting screws to draw filter cover to the sump. Failure to comply may result in damage to cover, seals, or sump.

**CAUTION**

Do not use soap or alkalies for cleaning tank interiors. Failure to comply may result in damage to equipment.

**CAUTION**

Do not use wrench to tighten fuel filter. Failure to comply may result in damage to equipment.

**CAUTION**

Drain plug is magnetized and can not be exchanged with fill plug. Failure to comply may result in damage to equipment.

**CAUTION**

During installation of bottom brake shoe, an assistant is required to support brake shoe until springs are installed. Failure to comply may result in damage to equipment.

**CAUTION**

Ensure all connectors and wiring are free before lifting hood from vehicle. Failure to comply may result in damage to equipment.

**CAUTION**

Ensure all connectors remain disconnected while performing Steps (11) through (22). Failure to comply may result in damage to equipment.

**CAUTION**

Ensure all GFE cables, wire harnesses, fire suppression lines, and connectors are away from antenna platform. Remove antenna platform slowly from vehicle. Failure to comply may result in damage to equipment.

**CAUTION**

Ensure all GFE is disconnected prior to removal of GFE wire bundles. Failure to comply may result in damage to equipment.

**CAUTION**

Ensure all hoses, lines, harnesses, cables, and wires are clear of powertrain installation path. Failure to comply may result in damage to equipment.

**CAUTION**

Ensure all hoses, lines, harnesses, cables, and wires are not attached to powertrain. Failure to comply may result in damage to equipment.

**CAUTION**

Ensure all wires and cables are clear of HVAC installation path. Failure to comply may result in damage to equipment.

**CAUTION**

Ensure all wires and cables are clear of HVAC removal path. Failure to comply may result in damage to equipment.

**CAUTION**

Ensure any open tube, line, or fitting on the turbocharger and its related systems are capped and plugged. Failure to comply may result in damage to equipment.

**CAUTION**

Ensure assistant is holding knuckle securely. Failure to comply may result in damage to equipment.

**CAUTION**

Ensure batteries are disconnected. Batteries will discharge during storage if not disconnected. Failure to comply may result in damage to equipment.

**CAUTION**

Ensure battery disconnect switch is turned OFF prior to performing battery maintenance. Failure to comply may result in damage to equipment.

**CAUTION**

Ensure cables and hoses are positioned above transmission during installation. Failure to comply may result in damage to equipment.

**CAUTION**

Ensure cables and hoses are positioned above transmission during removal. Failure to comply may cause damage to equipment.

**CAUTION**

Ensure cables are installed correctly on NATO slave receptacle. Terminal assembly is offset from center of receptacle. Positive terminal (red cable) is closest to the center of receptacle. Negative (black cable) is farther away from center of receptacle. Failure to comply may result in damage to equipment.

**CAUTION**

Ensure connectors are completely seated. Failure to comply may result in damage to equipment.

**CAUTION**

Ensure correct oil level. Low level causes lack of lubrication and reduces durability. High level causes splashing and leads to overheating of transfer case.

**CAUTION**

Ensure engine is full of oil prior to starting engine. Failure to comply may result in damage to equipment.

**CAUTION**

Ensure longer bolt is installed in top position. Failure to comply may result in damage to equipment.

**CAUTION**

Ensure mating surfaces of differential lock chamber, shim plates, and differential assembly are clean to prevent differential leaks. Failure to comply may result in damage to equipment.

**CAUTION**

Ensure pilot is installed on base prior to removal. Failure to comply may result in damage to equipment.

**CAUTION**

Ensure retractor straps are secured prior to removing retractors. Failure to comply may result in damage to equipment.

**CAUTION**

Ensure setscrews are recessed no further than past side belly deflector panel or crossmember will not be held in place and may come off with panel. Failure to comply may result in damage to equipment.

**CAUTION**

Ensure spline cover is completely covering spindle splines and threads when installing hub assembly. Failure to comply may result in damage to equipment.

**CAUTION**

Ensure the rear light wire harness, fire suppression sensor wires, fire suppression lines, and Check-6 cables are properly routed prior to installing cargo deck on vehicle. Failure to comply may result in damage to equipment.

**CAUTION**

Ensure tires are not resting on surface containing grease or oil. Failure to comply may result in damage to equipment.

**CAUTION**

Ensure transmission oil level is at normal operating range. Failure to comply may result in damage to transmission.

**CAUTION**

Ensure wires, harnesses, lines, and hoses are clear from back of power steering reservoir during installation. Failure to comply may result in damage to equipment.

**CAUTION**

Excess sensor cable must be secured to air line to prevent it from contacting propeller shaft. Failure to comply may result in damage to equipment.

**CAUTION**

Failure to perform Step (1) may result in damage to equipment.

**CAUTION**

Failure to perform Step (3) may result in damage to equipment.

**CAUTION**

Fan shroud housing and fan are difficult to install. Use care not to damage radiator. Install with the aid of an assistant. Failure to comply may result in damage to equipment.

**CAUTION**

Fan shroud housing and fan are difficult to remove. Remove with the aid of an assistant and use care not to damage radiator. Failure to comply may result in damage to equipment.

**CAUTION**

Fill fuel filter with clean fuel before installing. Failure to comply may result in damage to equipment.

**CAUTION**

Fill shock slowly. Failure to comply may result in damage to equipment.

**CAUTION**

For installation of differential in housing, install 3/8 x 1/2 inch screw into differential lock-up screw hole prior to installing differential assembly into housing. Failure to comply may result in damage to equipment.

**CAUTION**

For removal of differential from housing, install 3/8 x 1/2 in. screw into differential assembly lock-up screw hole prior to removing inner shaft. Failure to comply may result in damage to equipment.

**CAUTION**

Front and rear brake drums are not interchangeable. Ensure brake drums are not switched during removal and installation. Failure to comply may result in damage to equipment.

**CAUTION**

Front rubber mounts may need to remain uninstalled until oil pan has cleared front mounting position. Failure to comply may result in damage to equipment.

**CAUTION**

Have an assistant monitor powertrain-to-chassis clearance during installation. Failure to comply may result in damage to equipment.

**CAUTION**

Have an assistant monitor powertrain-to-chassis clearance during removal. Failure to comply may result in damage to equipment.

**CAUTION**

HVAC hose needs at least one inch (2.54 cm) clearance from drive belt. Failure to comply may result in damage to equipment.

**CAUTION**

If coolant is being replaced, mix coolant into 50/50 mixture of coolant and distilled water. Do not have more than 60% coolant in mixture. Failure to comply may result in damage to equipment.

**CAUTION**

If tabs and notches do not line up, tighten beyond specified torque value until two tabs align. Never back off the retainer to align restraining tabs. Failure to comply may result in damage to equipment.

**CAUTION**

Install same number of shim plates as was removed. Failure to comply may result in damage to equipment.

**CAUTION**

Ladder structure panel utilizes foam inserts on underside. Ensure panel is supported in a way which protects the foam inserts while lifting into place on vehicle. Failure to comply may result in damage to equipment.

**CAUTION**

Ladder structure panel utilizes foam inserts on underside. Ensure panel is supported in a way which protects the foam inserts while removing from vehicle. Failure to comply may result in damage to equipment.

**CAUTION**

Litter door must be placed on a soft, flat surface before removing dyneema panel. Failure to comply may result in damage to equipment.

**CAUTION**

Loosen jam nut prior to removal of setscrew from differential lock chamber. Failure to comply may result in damage to equipment.

**CAUTION**

Only remove hood support bracket far enough away from capsule for access of remaining hardware. Failure to comply may result in damage to equipment.

**CAUTION**

Overtightening will cause deformation of the pipe fitting and damage to the joining fitting, flange, or component. Failure to comply may result in damage to equipment.

**CAUTION**

Perform Steps (5) through (8) for operation checks. Failure to comply may cause damage to vehicle.

**CAUTION**

Position tire assembly so that CTIS hole in tire assembly is aligned with CTIS port. Damage to CTIS system may result if tire assembly is not correctly installed. Failure to comply may result in damage to equipment.

**CAUTION**

Powertrain must be installed carefully with a combination of downward and rearward movements. Failure to comply may result in damage to equipment.

**CAUTION**

Powertrain must be removed carefully with a combination of forward and upward movements. Failure to comply may result in damage to equipment.

**CAUTION**

Prior to installing and adjusting setscrew, air system must be charged. Failure to comply may result in damage to equipment.

**CAUTION**

Prior to performing the installation process, ensure inside of canister and housing are clean. Place clean cloth on hard surface. Failure to comply may result in damage to equipment.

**CAUTION**

Prior to removing sensor, carefully remove sealant from cable and knuckle. Failure to comply may result in damage to equipment.

**CAUTION**

Raise transmission only enough to release pressure on spring support. Failure to comply will result in damage to equipment.

**CAUTION**

Rear cargo door must be placed on a soft, flat surface before removing dyneema panel. Failure to comply may result in damage to equipment.

**CAUTION**

Rear wall panel must be placed on a soft, flat surface before removing dyneema panel. Failure to comply may result in damage to equipment.

**CAUTION**

Remove old sealing remainders from threads on the shift cylinder cover, adjustment screw, and locknut. Failure to comply may result in damage to equipment.

**CAUTION**

Remove remaining gasket remnants from top surface of thermostat housing and bottom surface of thermostat outlet weldment. Prepare both surfaces for new gasket. Failure to comply may result in damage to equipment.

**CAUTION**

Retaining springs may fit loosely in seals. Ensure retaining springs are installed during installation of seals. Failure to comply may result in damage to equipment.

**CAUTION**

Small piece of tape wound around end of cable will aid in installation.

**CAUTION**

Strip wire after placing it through seal to prevent damage to individual wire strands. Failure to comply may result in damage to equipment.

**CAUTION**

Support ignition relay during installation to prevent relay from hanging by wires. Failure to comply may result in damage to equipment.

**CAUTION**

Support ignition relay during removal to prevent relay from hanging by wires. Failure to comply may result in damage to equipment.

**CAUTION**

Support power steering reservoir during front bracket removal. Power steering reservoir could shift when front bracket is removed. Failure to comply may result in damage to equipment.

**CAUTION**

Support power steering reservoir until mounting bracket is secured. Failure to comply may result in damage to equipment.

**CAUTION**

Take care to prevent kinks from forming in cable, as this will weaken cable. Failure to comply may result in damage to equipment.

**CAUTION**

Take care when removing brackets from hood. Hood will no longer be secured if removing both brackets. Failure to comply may result in damage to equipment.

**CAUTION**

Tension rods are loosened and not removed in Step (1). Failure to comply may result in damage to equipment.

**CAUTION**

Terminals come in different styles and sizes. To prevent damage, be sure to use only the exact replacements. Do not attempt to modify terminal to fit. Failure to comply may result in damage to equipment.



**CAUTION**

The life of a cable directly relates to its use and to the care it receives. A cable must be “stretched” or spooled onto the drum under a load of at least 500 lbs (227 kg). The objective of “stretching” is to produce tight, even wraps on the inner and outer layers of the cable, thus preventing binding or kinking. Failure to comply may result in damage to equipment.

**CAUTION**

The transmission must not be operated for extended periods of time until a hot check has verified proper oil level. Do not operate transmission for extended periods at improper oil level conditions. Failure to comply may result in damage to equipment.

**CAUTION**

Tighten screws in a crisscross pattern. Failure to comply may result in damage to equipment.

**CAUTION**

Torque adapter must be 90° to torque wrench. Failure to comply may result in damage to equipment.

**CAUTION**

Tube must be fully removed from tie down pass through prior to lifting cargo deck. Failure to comply may result in damage to equipment.

**CAUTION**

Turn battery disconnect switch to the OFF position prior to inspecting and/or disconnecting any electrical connector for the fire suppression system. Failure to comply may result in damage to equipment.

**CAUTION**

Use brass drift to tap in bearing cups. Failure to comply may result in damage to equipment.

**CAUTION**

Use care not to damage components while prying apart. Failure to comply may result in damage to equipment.

**CAUTION**

Use care when connecting connectors. Failure to comply may result in damage to equipment.

**CAUTION**

Use care when installing new bearing, to prevent accidental damage to bearing. Failure to comply may result in damage to equipment.

**CAUTION**

Use care when installing screws into threaded blocks for front seat. If a threaded block is loosened, removal of belly armor is required to properly secure the seat.

**CAUTION**

Use care when installing wheel/tire assembly. Dragging wheel/tire assembly across studs may result in damage to studs. Failure to comply may result in damage to equipment.

**CAUTION**

Use caution when inserting tension rods through vehicle. Ensure tension rods do not contact air lines, hydraulic hoses, or wire harnesses. Failure to comply may result in damage to equipment.

**CAUTION**

Use caution when removing tension rods from vehicle. Ensure tension rods do not contact air lines, hydraulic hoses, or wire harnesses. Failure to comply may result in damage to equipment.

**CAUTION**

Use caution while installing cargo deck on vehicle. Ensure nothing becomes caught or bound during installation. Failure to comply may result in damage to equipment.

**CAUTION**

Use caution while removing cargo deck from vehicle. Ensure wire harness, fire suppression sensor wires, fire suppression lines, and Check-6 cables do not become caught or bound during removal. Failure to comply may result in damage to equipment.

**CAUTION**

Vehicle armor is threaded; do not attempt to force screw out. Screw must be turned out. Failure to comply may result in damage to equipment.

**CAUTION**

Vehicles must not have ballistic glass cleaned with solvent or other strong cleaning compounds. Ballistic glass must only be cleaned with a lint-free cloth and a mild solution of warm water and soap. Failure to comply may result in damage to equipment.

**CAUTION**

Washer (5) and washer (8) are not interchangeable. Note their location. Failure to comply may result in damage to equipment.

**CAUTION**

Washers (5 and 8) are not interchangeable. Switching washers during installation may cause damage to equipment.

**CAUTION**

When drilling out threaded insert, do not enlarge existing hole. The new threaded insert will not seat properly if hole is enlarged. Failure to comply may result in damage to equipment.

**CAUTION**

When installing hub assembly on spindle, install hub assembly in one straight, smooth, continuous process. Do not stop during process and relax hub assembly on CTIS seals. Use care not to drag hub assembly along spindle shaft. Failure to comply may result in damage to equipment.

**CAUTION**

When installing pitman arm, timing marks on pitman arm and steering output shaft must be aligned as noted prior to removal. Failure to comply may result in damage to equipment.

**CAUTION**

When installing propeller shaft on yoke, ensure bearing caps remain on universal joint. Failure to comply may result in lost or damaged needle bearings.

**CAUTION**

When one brake shoe needs to be replaced, all brake shoes for that axle must be replaced. Failure to comply may result in damage to equipment.

**CAUTION**

When removing and installing battery terminals and cables from batteries, ensure they are removed and installed in proper sequence as described below. Failure to comply may result in damage to equipment.

**CAUTION**

When removing differential lock chamber from differential assembly, note number of shims removed. Same number of shims must be used when installing lock chamber. Failure to comply may result in damage to equipment.

**CAUTION**

When removing propeller shaft from yokes, ensure bearing caps remain on universal joint. Failure to comply may result in lost or damaged needle bearings.

**CAUTION**

When removing seal from spindle, do not damage spindle bore where seal is seated. Failure to comply may result in damage to equipment.

**CAUTION**

When removing washer from sun gear, do not damage surface of sun gear. Failure to comply may result in damage to equipment.

**CAUTION**

When tightening A/C hoses and fittings, always use a backup wrench. Failure to comply may result in damage to equipment.

**CAUTION**

When using a pressure washer to clean capsule interior, do not allow stream to contact dash, dash components, or other electrical components. Failure to comply may result in damage to equipment.

**CAUTION**

When using a pressure washer to clean capsule interior, keep nozzle of pressure washer away from vehicle or components a distance of 5 ft. (1.5 m) or more. Failure to comply may result in damage to equipment.

**CAUTION**

When using a pressure washer to clean vehicle, do not allow water stream to contact dash, dash components, or other electrical components. Failure to comply may result in damage to equipment.

**CAUTION**

While tightening nuts, hold screws with wrench. Failure to comply may result in damage to equipment.

## LIST OF EFFECTIVE PAGES/WORK PACKAGES

NOTE: This manual supersedes TM 9-2355-335-23-2 dated 15 June 2011. Zero in the "Change No." column indicates an original page or work package.

Date of issue for the original manual is:

Original    28 February 2013

**IN VOLUME 2, THE TOTAL NUMBER OF PAGES FOR FRONT AND REAR MATTER IS 158 AND TOTAL NUMBER OF WORK PACKAGES IS 114 , CONSISTING OF THE FOLLOWING:**

Page/WP No.	Change No.	Page/WP No.	Change No.
<b>Volume 2</b>		WP 0214 (10 pgs) . . . . .	0
Cover . . . . .	0	WP 0215 (2 pgs) . . . . .	0
Safety Summary ( 38 pgs) . . . . .	0	WP 0216 (2 pgs) . . . . .	0
i thru vi . . . . .	0	WP 0217 (4 pgs) . . . . .	0
WP 0184 (2 pgs) . . . . .	0	WP 0218 (34 pgs) . . . . .	0
WP 0185 (6 pgs) . . . . .	0	WP 0219 (6 pgs) . . . . .	0
WP 0186 (4 pgs) . . . . .	0	WP 0220 (2 pgs) . . . . .	0
WP 0187 (10 pgs) . . . . .	0	WP 0221 (2 pgs) . . . . .	0
WP 0188 (4 pgs) . . . . .	0	WP 0222 (4 pgs) . . . . .	0
WP 0189 (6 pgs) . . . . .	0	WP 0223 (8 pgs) . . . . .	0
WP 0190 (4 pgs) . . . . .	0	WP 0224 (4 pgs) . . . . .	0
WP 0191 ( 8 pgs) . . . . .	0	WP 0225 (2 pgs) . . . . .	0
WP 0192 (4 pgs) . . . . .	0	WP 0226 (2 pgs) . . . . .	0
WP 0193 (4 pgs) . . . . .	0	WP 0227 (4 6 pgs) . . . . .	0
WP 0194 (10 pgs) . . . . .	0	WP 0228 (12 pgs) . . . . .	0
WP 0195 (4 pgs) . . . . .	0	WP 0229 (2 pgs) . . . . .	0
WP 0196 (6 pgs) . . . . .	0	WP 0230 (2 pgs) . . . . .	0
WP 0197 (2 pgs) . . . . .	0	WP 0231 (2 pgs) . . . . .	0
WP 0198 (2 pgs) . . . . .	0	WP 0232 (4 pgs) . . . . .	0
WP 0199 (4 pgs) . . . . .	0	WP 0233 (2 pgs) . . . . .	0
WP 0200 (2 pgs) . . . . .	0	WP 0234 (2 pgs) . . . . .	0
WP 0201 (2 pgs) . . . . .	0	WP 0235 (8 pgs) . . . . .	0
WP 0202 (2 pgs) . . . . .	0	WP 0236 (2 pgs) . . . . .	0
WP 0203 (4 pgs) . . . . .	0	WP 0237 (2 pgs) . . . . .	0
WP 0204 (2 pgs) . . . . .	0	WP 0238 (4 pgs) . . . . .	0
WP 0205 (2 pgs) . . . . .	0	WP 0239 (2 pgs) . . . . .	0
WP 0206 (4 pgs) . . . . .	0	WP 0240 (4 pgs) . . . . .	0
WP 0207 (2 pgs) . . . . .	0	WP 0241 (6 pgs) . . . . .	0
WP 0208 (2 pgs) . . . . .	0	WP 0242 (4 pgs) . . . . .	0
WP 0209 (4 pgs) . . . . .	0	WP 0243 (46 pgs) . . . . .	0
WP 0210 (4 pgs) . . . . .	0	WP 0244 (2 6 pgs) . . . . .	0
WP 0211 (2 pgs) . . . . .	0	WP 0245 (6 pgs) . . . . .	0
WP 0212 (6 pgs) . . . . .	0	WP 0246 (4 pgs) . . . . .	0
WP 0213 (2 pgs) . . . . .	0	WP 0247 (8 pgs) . . . . .	0

Page/WP No.	Change No.	Page/WP No.	Change No.
WP 0248 (24 pgs)	0	WP 0275 (2 pgs)	0
WP 0249 (8 pgs)	0	WP 0276 (4 pgs)	0
WP 0250 (12 pgs)	0	WP 0277 (14 pgs)	0
WP 0251 (10 pgs)	0	WP 0278 (4 pgs)	0
WP 0252 (12 pgs)	0	WP 0279 (4 pgs)	0
WP 0253 (2 pgs)	0	WP 0280 (4 pgs)	0
WP 0254 (6 pgs)	0	WP 0281 (4 pgs)	0
WP 0255 (8 pgs)	0	WP 0282 (12 pgs)	0
WP 0256 (4 pgs)	0	WP 0283 (4 pgs)	0
WP 0257 (2 pgs)	0	WP 0284 (4 pgs)	0
WP 0258 (4 pgs)	0	WP 0285 (6 pgs)	0
WP 0259 (4 pgs)	0	WP 0286 (4 pgs)	0
WP 0260 (10 pgs)	0	WP 0287 (4 pgs)	0
WP 0261 (8 pgs)	0	WP 0288 (4 pgs)	0
WP 0262 (2 pgs)	0	WP 0289 (4 pgs)	0
WP 0263 (4 pgs)	0	WP 0290 (6 pgs)	0
WP 0264 (8 pgs)	0	WP 0291 (16 pgs)	0
WP 0265 (4 pgs)	0	WP 0292 (16 pgs)	0
WP 0266 (4 pgs)	0	Chp 5 Title page	0
WP 0267 (4 pgs)	0	WP 0293 (2 pgs)	0
WP 0268 (2 pgs)	0	WP 0294 (4 pgs)	0
WP 0269 (4 pgs)	0	WP 0295 (24 pgs)	0
WP 0270 (8 pgs)	0	WP 0296 (4 pgs)	0
WP 0271 (8 pgs)	0	WP 0297 (10 pgs)	0
WP 0272 (2 pgs)	0	Schematics (98 pgs)	0
WP 0273 (4 pgs)	0		
WP 0274 (4 pgs)	0		

HEADQUARTERS  
DEPARTMENT OF THE ARMY  
WASHINGTON, D.C., 28 February 2013

**MAINTENANCE MANUAL**  
**COMMERCIAL-OFF-THE-SHELF (COTS)**  
for  
**MINE RESISTANT AMBUSH PROTECTED**  
**ALL TERRAIN VEHICLE (M-ATV)**  
  
**M1240**  
**NSN: 2355-01-575-9632 (EIC 1UT)**  
  
**M1240A1**  
**NSN: 2355-01-596-1330 (EIC 1ZW)**  
  
**M1245**  
**NSN: 2355-01-586-8070 (EIC 1VE)**

**REPORTING ERRORS AND RECOMMENDING IMPROVEMENTS**

(A) Army - You can help improve this publication. If you find any errors, or if you would like to recommend any improvements to the procedures in this publication, please let us know. The preferred method is to submit your DA Form 2028 (Recommended Changes to Publications and Blank Forms) through the Internet on the TACOM Unique Logistics Support Applications (TULSA) Web site. The Internet address is <https://tulsa.tacom.army.mil>. Access to all applications requires CAC authentication, and you must complete the Access Request form the first time you use it. The DA Form 2028 is located under the TULSA Applications on the left-hand navigation bar. Fill out the form and click on SUBMIT. Using this form on the TULSA Web site will enable us to respond more quickly to your comments and to better manage the DA Form 2028 program. You may also mail, e-mail, or fax your comments or DA Form 2028 directly to the U.S. Army TACOM Life Cycle Management Command. The postal mail address is U.S. Army TACOM Life Cycle Management Command, ATTN: AMSTA-LCL-MPP/ TECH PUBS, MS 727, 6501 E. 11 Mile Road, Warren, MI 48397-5000. The e-mail address is [tacomlcmc.daform2028@us.army.mil](mailto:tacomlcmc.daform2028@us.army.mil). The fax number is DSN 786-1856 or Commercial (586) 282-1856. A reply will be furnished to you.

(F) Air Force - For users without access to JCALS, submit AFTO Form 22 directly to WR/ALC/GRVEB, Robins AFB GA. Send in your recommended changes via electronic mail. Our e-mail address is [robins.ce.afto22@robins.af.mil](mailto:robins.ce.afto22@robins.af.mil).

\*This manual supersedes TM 9-2355-335-23-2, dated 15 June 2011.

**COPYRIGHT RELEASE STATEMENT:** Oshkosh Corporation states this Commercial Off the Shelf (COTS) manual dated 28 February 2013 is free from copyright restrictions. The Government may edit, reprint, and distribute information in this manual as required.

**DISTRIBUTION STATEMENT C:** Distribution authorized to US Government agencies and their contractors; proprietary information. This publication is Administrative-Operational Use required for administrative and operational purposes, as determined on 02 October 2009. Other requests for this document shall be referred to U.S. Army TACOM Life Cycle Management Command, PM-MRAP, ATTN: AMSTA-LCC-MM/TECH PUBS, 6501 E. 11 Mile Road, Warren, MI 48397-5000.

**DESTRUCTION NOTICE:** Destroy by any method that will prevent disclosure of contents or reconstruction of the document.





## TABLE OF CONTENTS

WP Sequence No.

**VOLUME 2**

**CHAPTER 4 MAINTENANCE INSTRUCTIONS - CONTINUED**

**ELECTRICAL**

12-Volt Power Convertor Replacement . . . . .	WP 0184
Alternator Replacement . . . . .	WP 0185
Batteries Disconnect/Connect (M1240/M1240A1). . . . .	WP 0186
Batteries Disconnect/Connect (M1245). . . . .	WP 0187
Battery Disconnect Switch Replacement. . . . .	WP 0188
Battery Isolator Replacement . . . . .	WP 0189
Battery PDU Box Replacement (M1245). . . . .	WP 0190
Battery Replacement (M1240/M1240A1) . . . . .	WP 0191
Blackout Drivelight Replacement. . . . .	WP 0192
Check-6 Rear Composite Light Replacement . . . . .	WP 0193
Circuit Breaker Replacement, Auxiliary (M1240/M1240A1) . . . . .	WP 0194
Circuit Breaker Replacement, Dash . . . . .	WP 0195
Clearance Lights Replacement . . . . .	WP 0196
Deicer Circuit Breaker Replacement . . . . .	WP 0197
Dimmer Replacement . . . . .	WP 0198
Electromagnetic Interference (EMI) Filter Replacement . . . . .	WP 0199
Flasher Replacement . . . . .	WP 0200
Front Composite Light Replacement . . . . .	WP 0201
Headlight Replacement . . . . .	WP 0202
Ignition Relay Replacement. . . . .	WP 0203
Infrared (IR) Light Replacement (M1245) . . . . .	WP 0204
Mk-44 Receptacle Replacement (M1245). . . . .	WP 0205
NATO Slave Receptacle Replacement (For Vehicles With Updated SPARK Or M1245) . . . . .	WP 0206
Parking Brake Stoplight Switch Replacement . . . . .	WP 0207
PDU Deck Box Replacement (M1245) . . . . .	WP 0208
Pressure Switch Replacement . . . . .	WP 0209
Rear Composite Light Replacement . . . . .	WP 0210
Reverse Light Replacement (M1240/M1240A1) . . . . .	WP 0211

## TABLE OF CONTENTS (CONTINUED)

	<u>WP Sequence No.</u>
<b>ELECTRICAL (continued)</b>	
Spotlight Controller Replacement . . . . .	WP 0212
Spotlight Replacement . . . . .	WP 0213
Starter Replacement . . . . .	WP 0214
Stoplight Switch Replacement . . . . .	WP 0215
Transmission Control Module (TCM) Replacement . . . . .	WP 0216
Voltage Regulator Replacement . . . . .	WP 0217
Wiring Harness Repair . . . . .	WP 0218
<b>ENGINE/TRANSMISSION</b>	
Air Compressor Replacement . . . . .	WP 0219
Air Conditioner Drive Belt Replacement . . . . .	WP 0220
Alternator Drive Belt Replacement . . . . .	WP 0221
Crankshaft Rear Seal Replacement . . . . .	WP 0222
Engine Electronic Control Module (ECM) Replacement . . . . .	WP 0223
Engine Oil Drain/Fill . . . . .	WP 0224
Engine Oil Filter Replacement . . . . .	WP 0225
Passenger Side Engine Panel Replacement (M1240/M1245) . . . . .	WP 0226
Powertrain Replacement . . . . .	WP 0227
Engine/Transmission Assembly/Disassembly . . . . .	WP 0228
Ring Gear and Flexplate Adapter Replacement . . . . .	WP 0229
Transmission Breather Replacement . . . . .	WP 0230
Transmission Cooler Replacement . . . . .	WP 0231
Transmission Drain/Fill . . . . .	WP 0232
Transmission Filter Replacement . . . . .	WP 0233
Transmission Spring Support and Bracket Replacement . . . . .	WP 0234
Turbocharger Assembly Replacement . . . . .	WP 0235
Vehicle Interface Module (VIM) Replacement . . . . .	WP 0236
Water Pump Belt Adjustment . . . . .	WP 0237
Water Pump Belt Replacement . . . . .	WP 0238
<b>EXHAUST</b>	
Exhaust Pipe Replacement (M1240/M1245) . . . . .	WP 0239
Exhaust Pipe Replacement (M1240A1) . . . . .	WP 0240
Muffler Replacement (M1240/M1245) . . . . .	WP 0241

**TABLE OF CONTENTS (CONTINUED)**

**WP Sequence No.**

**EXHAUST (continued)**

Muffler Replacement (M1240A1) . . . . . WP 0242

**FRAME**

Cargo Deck Replacement (M1245) . . . . . WP 0243

Cargo Deck Replacement (M1240/M1240A1) . . . . . WP 0244

Cargo Deck Litter Door Replacement (M1245) . . . . . WP 0245

Cargo Deck Litter Door Frame Replacement (M1245) . . . . . WP 0246

Cargo Deck Rear Wall Replacement (M1245) . . . . . WP 0247

Cargo Deck Rear Door Replacement (M1245) . . . . . WP 0248

Cargo Deck Side Wall Replacement (M1245) . . . . . WP 0249

Front Bumper Replacement (Standard SPARK) . . . . . WP 0250

Front Bumper Replacement (Updated SPARK) . . . . . WP 0251

GFE Cabinet Replacement (M1245) . . . . . WP 0252

Push Bumper Replacement (M1245) . . . . . WP 0253

Quick Lock Floor Replacement (M1245) . . . . . WP 0254

Rear Crossmember Replacement (M1240/M1240A1) . . . . . WP 0255

Spark Bar and Strut Replacement (Updated SPARK) . . . . . WP 0256

**FUEL**

Air Cleaner Assembly Replacement (M1240/M1245) . . . . . WP 0257

Air Cleaner Assembly Replacement (M1240A1) . . . . . WP 0258

Air Filter Replacement . . . . . WP 0259

Air Intake Hoses Replacement (M1240/M1245) . . . . . WP 0260

Air Intake Hoses Replacement (M1240A1) . . . . . WP 0261

Fuel Filter Replacement . . . . . WP 0262

Fuel Lines Replacement . . . . . WP 0263

Fuel Tank Replacement . . . . . WP 0264

Fuel/Water Separator Base Replacement . . . . . WP 0265

Fuel/Water Separator Filter Replacement . . . . . WP 0266

**WINCH**

Winch Cable Guide and Guard Replacement . . . . . WP 0267

Winch Cable Replacement (Standard SPARK) . . . . . WP 0268

Winch Cable Replacement (Updated SPARK) . . . . . WP 0269

Winch/Front Crossmember Replacement (Updated SPARK) . . . . . WP 0270

## TABLE OF CONTENTS (CONTINUED)

	<u>WP Sequence No.</u>
<b>WINCH (continued)</b>	
Winch Replacement (Standard SPARK) . . . . .	WP 0271
<b>STEERING</b>	
Lower Steering Shaft Replacement . . . . .	WP 0272
Middle Steering Shaft Replacement . . . . .	WP 0273
Pitman Arm Replacement . . . . .	WP 0274
Power Steering Filter Replacement . . . . .	WP 0275
Power Steering Pump Replacement . . . . .	WP 0276
Power Steering Reservoir and Bracket Replacement . . . . .	WP 0277
Power Steering Reservoir Drain/Fill . . . . .	WP 0278
Primary Steering Gear Replacement . . . . .	WP 0279
Secondary Steering Gear Replacement . . . . .	WP 0280
Steering Arm Replacement . . . . .	WP 0281
Steering Column and Bracket Replacement . . . . .	WP 0282
Steering Gear Mitre Replacement . . . . .	WP 0283
Steering Gear Relief Adjustment . . . . .	WP 0284
Steering Gear Tray Replacement . . . . .	WP 0285
Steering Wheel Replacement . . . . .	WP 0286
Tie Rod Replacement . . . . .	WP 0287
Toe Control Link Replacement, Axle No. 1 . . . . .	WP 0288
Toe Control Link Replacement, Axle No. 2 . . . . .	WP 0289
Upper Steering Shaft Replacement . . . . .	WP 0290
<b>TECHNICAL SUPPORT</b>	
General Maintenance . . . . .	WP 0291
Torque Instructions . . . . .	WP 0292
<b>CHAPTER 5 SUPPORTING INFORMATION</b>	
References . . . . .	WP 0293
Introduction For Standard Two-Level Maintenance Allocation Chart (MAC) . . . . .	WP 0294
Maintenance Allocation Chart (MAC) . . . . .	WP 0295
Expendable and Durable Items List . . . . .	WP 0296
Schematics Symbols . . . . .	WP 0297
Schematics . . . . .	Foldouts

---

**12-VOLT POWER CONVERTOR REPLACEMENT**

---

**Preconditions**

Park vehicle  
Engine OFF  
Wheels chocked  
Batteries disconnected (M1240/M1240A1)  
(WP 0186)  
Batteries disconnected (M1245) (WP 0187)

**Materials/Parts**

Locknuts (2) (Item 3)

**Follow-On Maintenance**

Connect batteries (M1240/1240A1) (WP 0186)  
Connect batteries (M1245) (WP 0187)  
Remove and stow wheel chocks

**Tools and Special Tools**

Tool Kit, General Mechanic's: Automotive

---

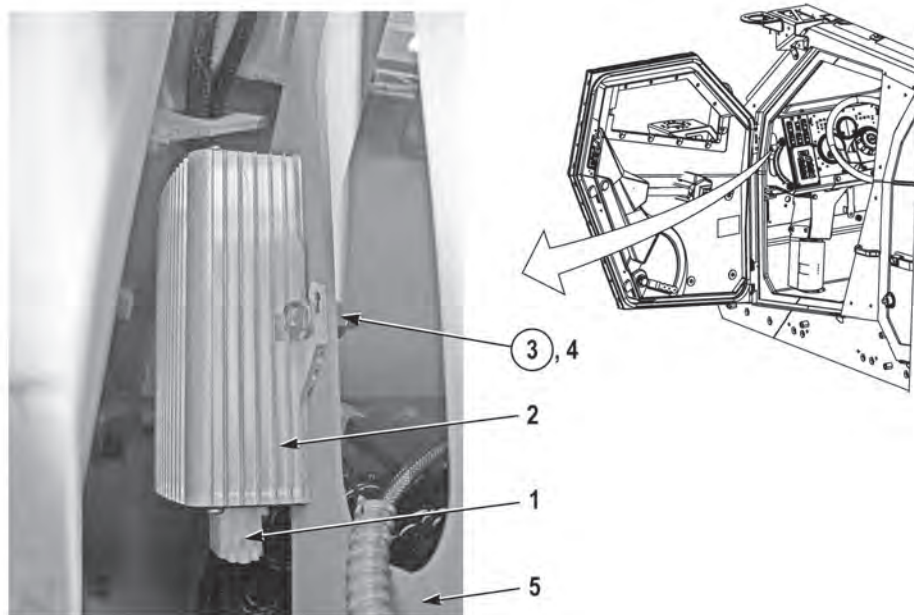
**REMOVAL**

1. Disconnect connector (1) from 12-volt converter (2).
2. Remove two locknuts (3), screws (4), and 12-volt converter (2) from dash (5). Discard locknuts (3).

**END OF TASK**

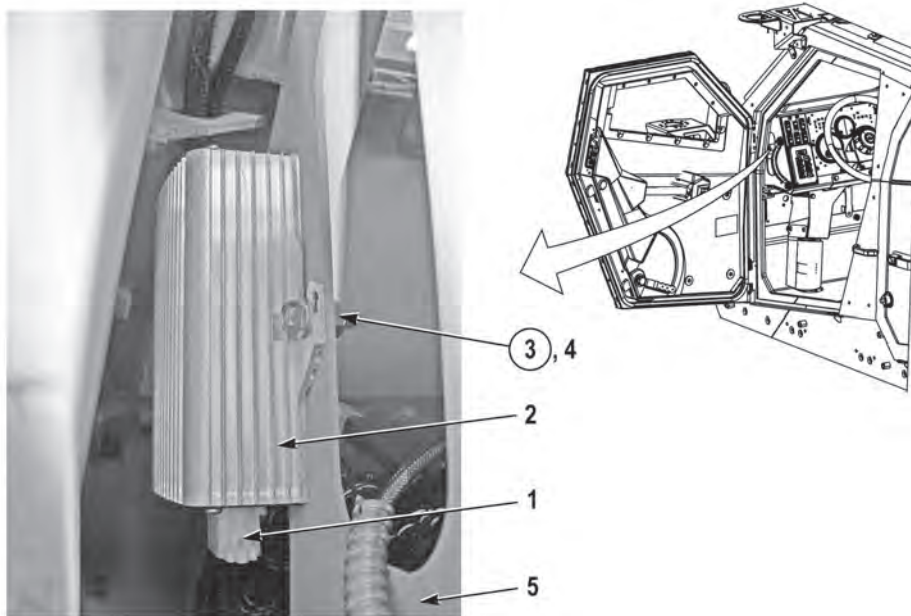
**INSTALLATION**

1. Install 12-volt converter (2) on dash (5) with two screws (4) and new locknuts (3).
2. Connect connector (1) to 12-volt converter (2).
3. Perform all Follow-On Maintenance tasks.

**END OF TASK****END OF WORK PACKAGE**

---

**ALTERNATOR REPLACEMENT**

---

**Preconditions**

Park vehicle  
Engine OFF  
Wheels chocked  
Hood opened and secured  
Alternator drive belt removed (WP 0221)  
Air cleaner assembly removed (WP 0257)  
Charge air cooler inlet hoses removed (M1240/  
M1245) (WP 0260)  
Charger air cooler inlet hoses removed  
(M1240A1) (WP 0261)

**Tools and Special Tools**

Lifting Device  
Tool Kit, General Mechanic's: Automotive  
Wrench, Torque, 250 ft-lb

**Materials/Parts**

Lockwasher (4) (Item 2, 7, 13, 17)  
Lockwasher (2) (Item 21)

**Materials/Parts (continued)**

Locknut (Item 25)  
Compound, Sealing, Novagard 200-257  
Tags, Identification  
Ties, Cable

**Personnel Required**

Three

**Follow-On Maintenance**

Install charge air cooler inlet hoses (M1240/  
M1245) (WP 0260)  
Install charge air cooler inlet hoses (M1240A1)  
(WP 0261)  
Install air cleaner assembly (WP 0257)  
Install alternator drive belt (WP 0221)  
Close hood and secure  
Remove and stow wheel chocks

---

**REMOVAL****WARNING**

**Engine components become hot during normal operation. Allow engine to cool completely prior to performing this task. Failure to comply may result in injury to personnel.**

**NOTE**

- Tag and mark cables and wires prior to removal to ensure proper installation.
- Remove cable ties as required.



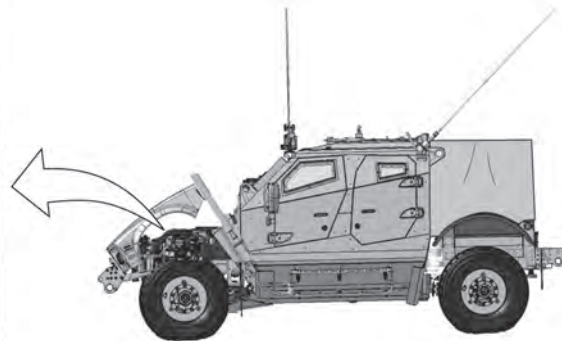
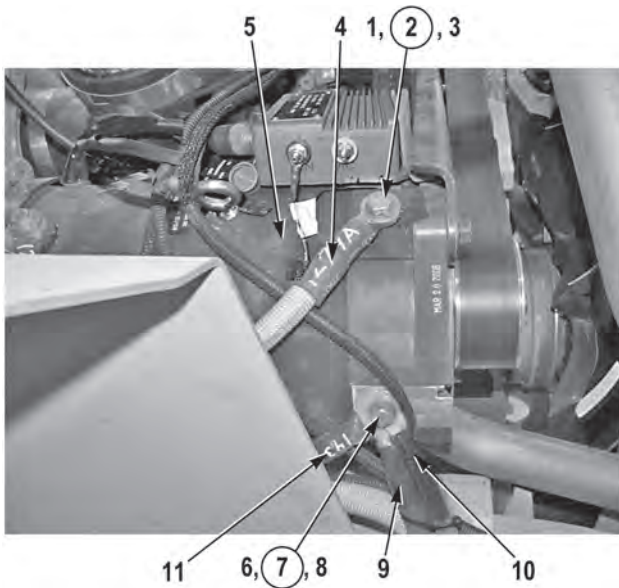

1. Remove screw (1), lockwasher (2), washer (3), and cable (4) from alternator (5). Discard lockwasher (2).
2. Remove screw (6), lockwasher (7), washer (8), ground strap (9), and two negative cables (10 and 11) from alternator (5). Discard lockwasher (7).

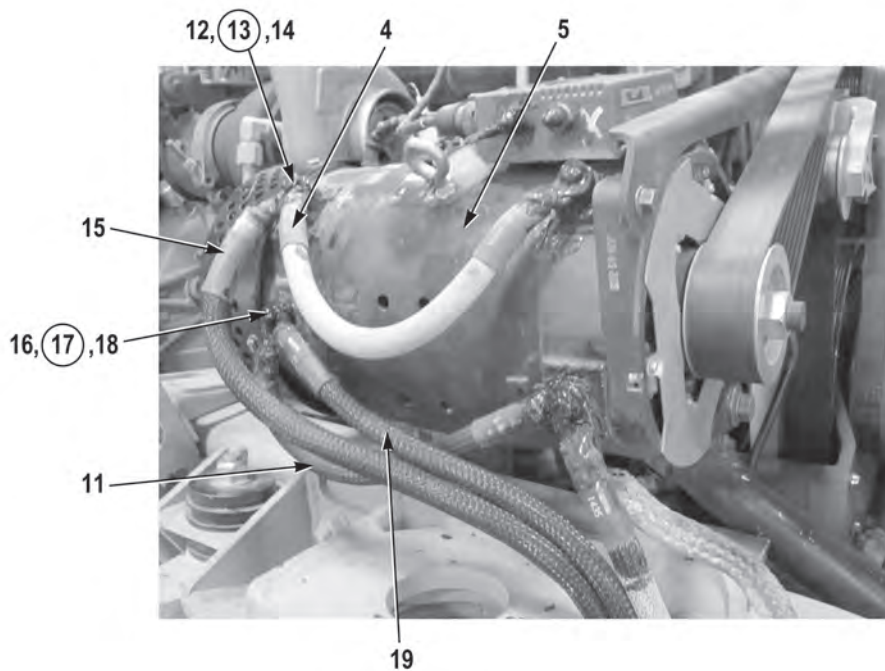

3. Remove screw (12), lockwasher (13), washer (14), and two cables (4 and 15) from alternator (5). Discard lockwasher (13).
4. Remove screw (16), lockwasher (17), washer (18), and cables (11 and 19) from alternator (5). Discard lockwasher (17).



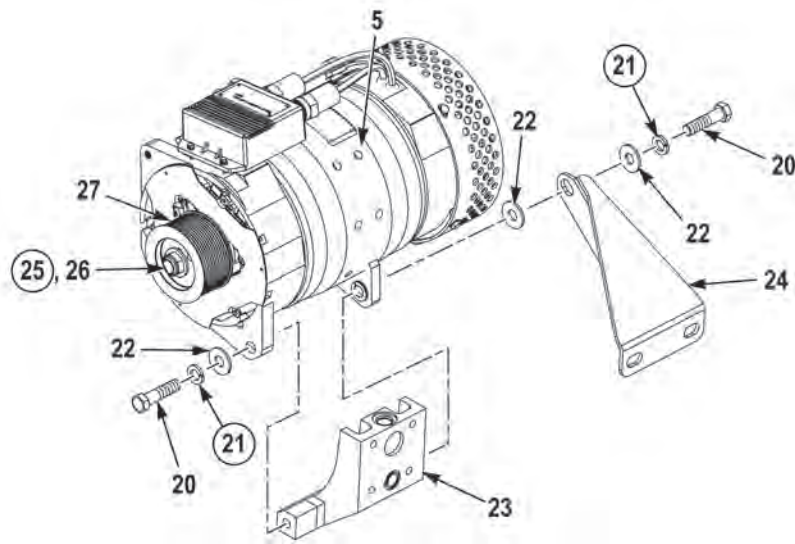

5. Remove support bracket from alternator and engine (WP 0217).

**WARNING**

**Alternator weighs 115 lbs (52 kg). Do not lift or move alternator without the aid of an assistant and lifting device. Failure to comply may result in injury or death to personnel.**

6. With the aid of an assistant and lifting device, remove two screws (20), lockwashers (21), three washers (22), and alternator (6) from two mounting brackets (23 and 24). Discard lockwashers (21).
7. Remove locknut (25), washer (26), and pulley (27) from alternator (6). Discard locknut (25).

**END OF TASK**

## INSTALLATION

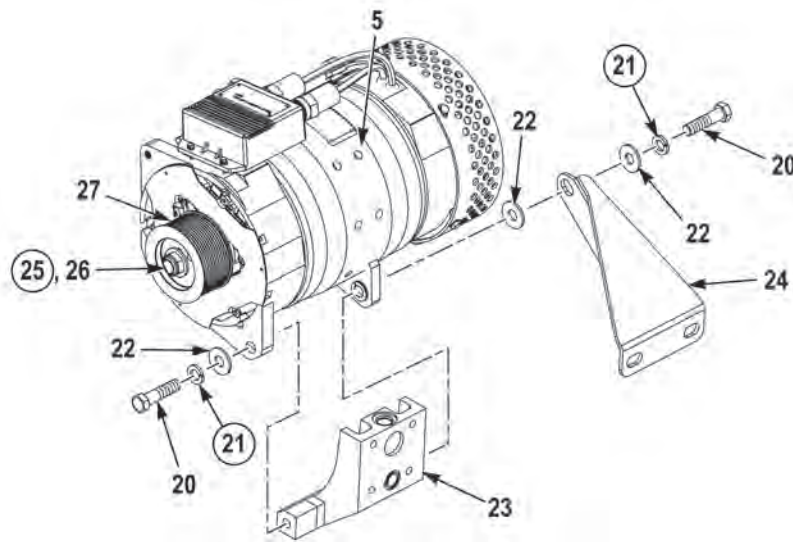

1. Install pulley (27) on alternator (5) with washer (26) and new locknut (25).

**WARNING**

**Alternator weighs 115 lbs (52 kg). Do not lift or move alternator without the aid of an assistant and lifting device. Failure to comply may result in injury or death to personnel.**

2. With the aid of two assistants and a lifting device, install alternator (5) on two mounting brackets (23 and 24) with three washers (22), two new lockwashers (21), and screws (20). Do not tighten screws.
3. Install support bracket on engine and alternator (WP 0217).
4. Tighten two screws (20) to 110 lb-ft (149 N•m).

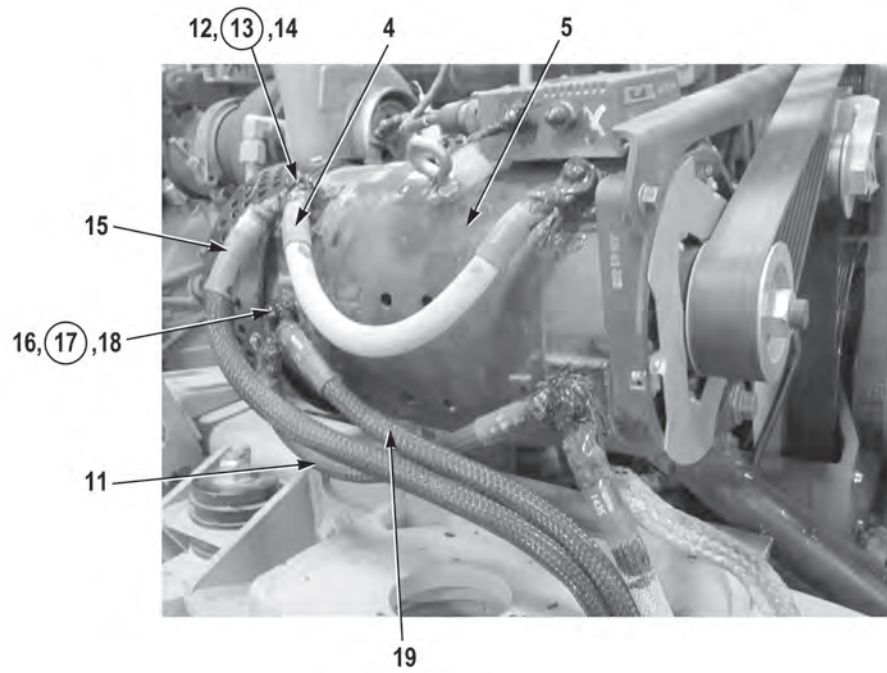

5. Install cables (19 and 11) on alternator (5) with washer (14), new lockwasher (13), and screw (12).
6. Install two cables (15 and 4) on alternator (5) with washer (18), new lockwasher (17), and screw (16).

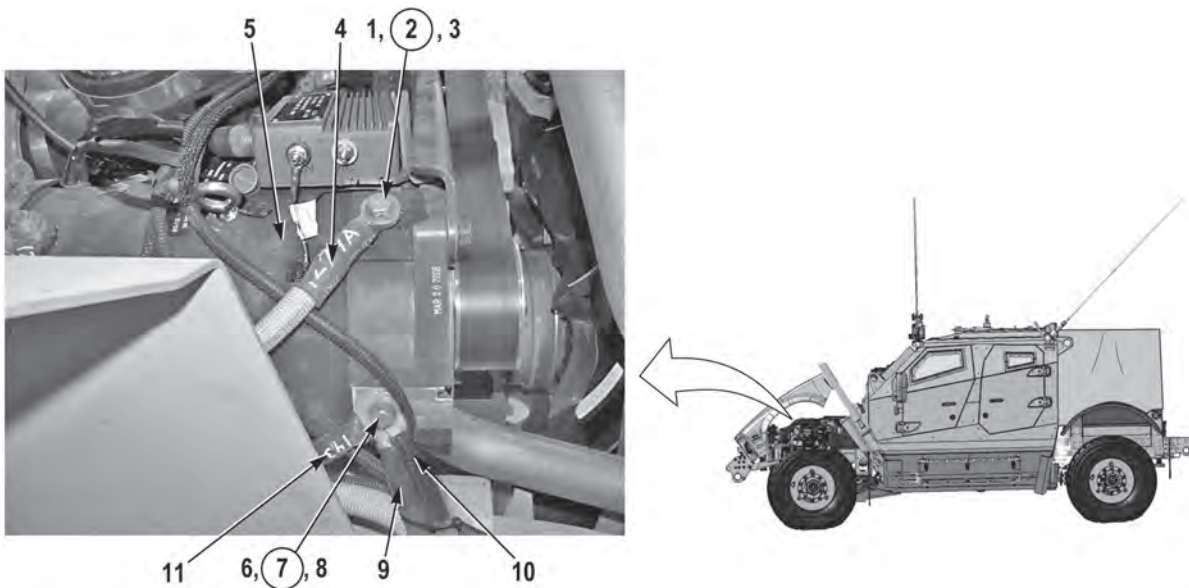

7. Install two negative cables (11 and 10) and ground strap (9) on alternator (5) with washer (8), new lockwasher (7), and screw (6).

#### NOTE

Install cable ties as required.

8. Install cable (4) on alternator (5) with washer (3), new lockwasher (2), and screw (1).

#### WARNING

**Adhesives, solvents, and sealing compounds can burn easily, can give off harmful vapors, and are harmful to skin and clothing. To avoid injury or death, keep away from open fire and use in well-ventilated area. If adhesive, solvent, or sealing compound gets on skin or clothing, wash immediately with soap and water. Failure to comply may result in injury or death to personnel.**

9. Apply sealing compound, Novagard 200-257, to four screws (1, 6, 12, and 16), lockwashers (2, 7, 13, and 17), washers (3, 8, 14, and 18), five cables (4, 10, 11, 15, and 19) and ground strap (9).
10. Perform all Follow-On Maintenance tasks.

**END OF TASK**

**END OF WORK PACKAGE**

---

**BATTERIES DISCONNECT/CONNECT (M1240/M1240A1)**

---

**Preconditions**

Park vehicle  
Engine OFF  
Wheels chocked

**Materials/Parts**

Cable Ties, Plastic  
Connector, Lubricant

**Tools and Special Tools**

Crowfoot, Flare Nut, 3/8 Dr., 1/2 in.  
Puller, Cable Clamp  
Tool Kit, General Mechanic's: Automotive  
Wrench, Torque, 0 to 300 in-lb

**Follow-On Maintenance**

Remove and stow wheel chocks

---

**DISCONNECT BATTERY****WARNING**

- **Use extreme care not to short out battery terminals. Remove all jewelry such as rings, ID tags, bracelets, etc. prior to working on or around vehicle. Jewelry and tools can catch on equipment, contact positive electrical circuits, and cause severe burns or electrical shock. Failure to comply may result in injury or death to personnel.**
- **Do not smoke, have open flame, or cause sparks near batteries. Batteries may explode. Failure to comply may result in injury or death to personnel.**
- **Battery acid is harmful to skin and eyes. Always wear safety goggles, acid-proof gloves, and a rubber apron when performing battery maintenance. Failure to comply may result in injury or death to personnel.**
- **Avoid electrolyte contact with skin and eyes. Failure to comply may result in injury or death to personnel.**

**NOTE**

- Two batteries are located in the cargo deck, on the driver side, used to start vehicle.
- Two batteries are located in the cargo deck, on the passenger side, used to power GFE in silent watch operations.
- The battery cases are marked with a (+) positive and a (-) negative to help identify battery polarity.

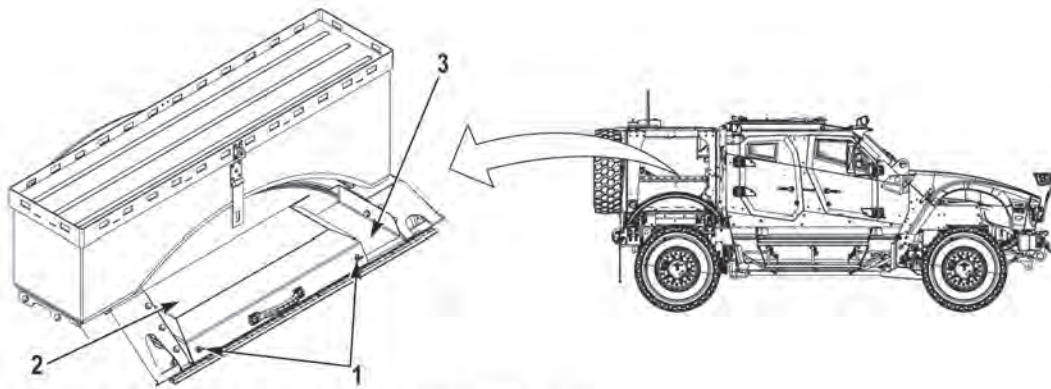

ANTENNA PLATFORM SHOWN REMOVED FOR CLARITY

### NOTE

- When removing terminal clamps from battery terminals, note position and location of connections prior to removal to ensure proper installation.
- Remove negative terminal clamp from front driver side and front passenger side battery only.
- Driver side and passenger side terminal clamps are disconnected the same way. Front passenger side shown.

1. Remove two thumbscrews (1) and battery cover (2) from cargo deck (3).

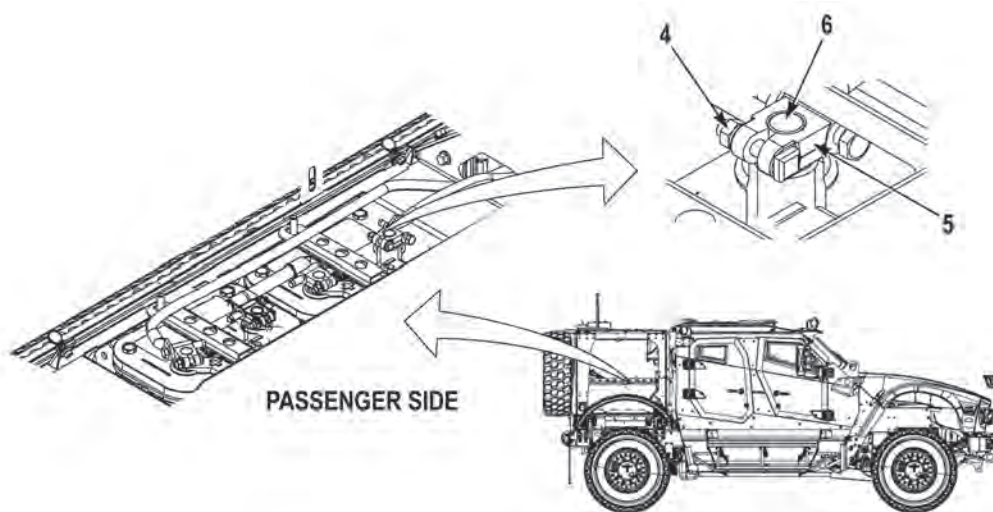

PASSENGER SIDE

### WARNING

Upon removal of terminal clamps, avoid accidental contact between terminal clamps and battery terminals. This will prevent accidental shorting, arcing, or sparks. Secure terminal clamps, cables, and wires away from battery terminals with cable ties as required. Failure to comply may result in injury or death to personnel.

2. Loosen nut (4) on terminal clamp (5).

3. Using cable clamp puller, remove terminal clamp (5) from negative battery terminal (6).
4. Repeat Steps (1) through (3) for driver side.

#### END OF TASK

#### CONNECT BATTERY

#### **WARNING**

- Use extreme care not to short out battery terminals. Remove all jewelry such as rings, ID tags, bracelets, etc. prior to working on or around vehicle. Jewelry and tools can catch on equipment, contact positive electrical circuits, and cause severe burns or electrical shock. Failure to comply may result in injury or death to personnel.
- Do not smoke, have open flame, or cause sparks near batteries. Batteries may explode. Failure to comply may result in injury or death to personnel.
- Battery acid is harmful to skin and eyes. Always wear safety goggles, acid-proof gloves, and a rubber apron when performing battery maintenance. Failure to comply may result in injury or death to personnel.
- Avoid electrolyte contact with skin and eyes. Failure to comply may result in injury or death to personnel.

#### **CAUTION**

**While tightening nuts, hold screws with wrench. Failure to comply may result in damage to equipment.**

1. Install terminal clamp (5) on negative battery terminal (6) and tighten nut (4). Tighten nut (4) to 84 to 96 lb-in (9.5 to 10.8 N•m).

#### **WARNING**

**Adhesives, solvents, and sealing compounds can burn easily, can give off harmful vapors, and are harmful to skin and clothing. To avoid injury or death, keep away from open fire and use in well-ventilated area. If adhesive, solvent, or sealing compound gets on skin or clothing, wash immediately with soap and water. Failure to comply may result in injury or death to personnel.**

2. Apply connector lubricant to battery terminals and terminal clamps.
3. Install battery cover (2) on cargo deck (3) with two thumbscrews (1).
4. Repeat Steps (1) through (3) for driver side.
5. Perform all Follow-On Maintenance tasks.

#### END OF TASK

#### END OF WORK PACKAGE





---

**BATTERIES DISCONNECT/CONNECT (M1245)**

---

**Preconditions**

Park Vehicle  
Engine OFF  
Wheels Chocked

**Tools and Special Tools**

Tool Kit, General Mechanic's: Automotive  
Wrench, Torque, 0 - 300 in-lb.

**Materials/Parts**

Lubricant, Connector  
Lockwasher (4) (Item 2)

**Follow-On Maintenance**

Remove and Stow Wheel Chocks

---

**DISCONNECT****WARNING**

- **Be careful not to short out battery terminal. Do not smoke or use open flame near batteries. Batteries may explode from spark. Failure to comply may result in injury or death to personnel.**
- **Lead-acid batteries contain sulfuric acid, which can cause severe burns. Avoid contact with skin, eyes, or clothing. Wear safety goggles and gloves. If battery electrolyte is spilled, take immediate action to stop its corrosive (burning) effects. If battery acid is spilled on clothing or vehicle, wash immediately with cold water. Neutralize with baking soda or household ammonia solution. If battery acid comes in contact with skin, flush with cold water to remove acid. If eyes are contacted, flush with cold water for at least 15 minutes. Seek immediate medical attention. If swallowed, drink large amounts of water or milk, follow with milk of magnesia, beaten egg, or vegetable oil. Seek immediate medical attention. Failure to comply may result in injury or death to personnel.**
- **Remove all jewelry, such as rings, dog tags, bracelets, etc. If jewelry contacts battery terminal or positive electrical circuit, a direct short may result in instant heating of tools, injury or death to personnel, or damage to equipment.**
- **To prevent arcing, do not allow tools to contact batteries or other battery terminals. Failure to comply may result in injury or death to personnel.**
- **Upon removal of wires and cables, ensure no contact is made with battery terminals or other wires and cables. Secure wires and cables away from battery terminals and other wires and cables as required. Failure to comply may result in injury or death to personnel or damage to equipment.**
- **Ensure batteries are disconnected when performing maintenance on or near batteries or electrical systems. Always remove negative battery terminals first. When reconnecting, always connect negative terminals last to avoid arcing or sparks that could cause an explosion.**

**DISCONNECT – CONTINUED****NOTE**

- Two batteries are located in the cargo deck, on the driver side, and are used to start the vehicle.
- Two batteries are located in the cargo deck, on the passenger side, and are used to power Government Furnished Equipment.
- The battery cases are marked with a (+) positive and a (-) negative to identify battery polarity.

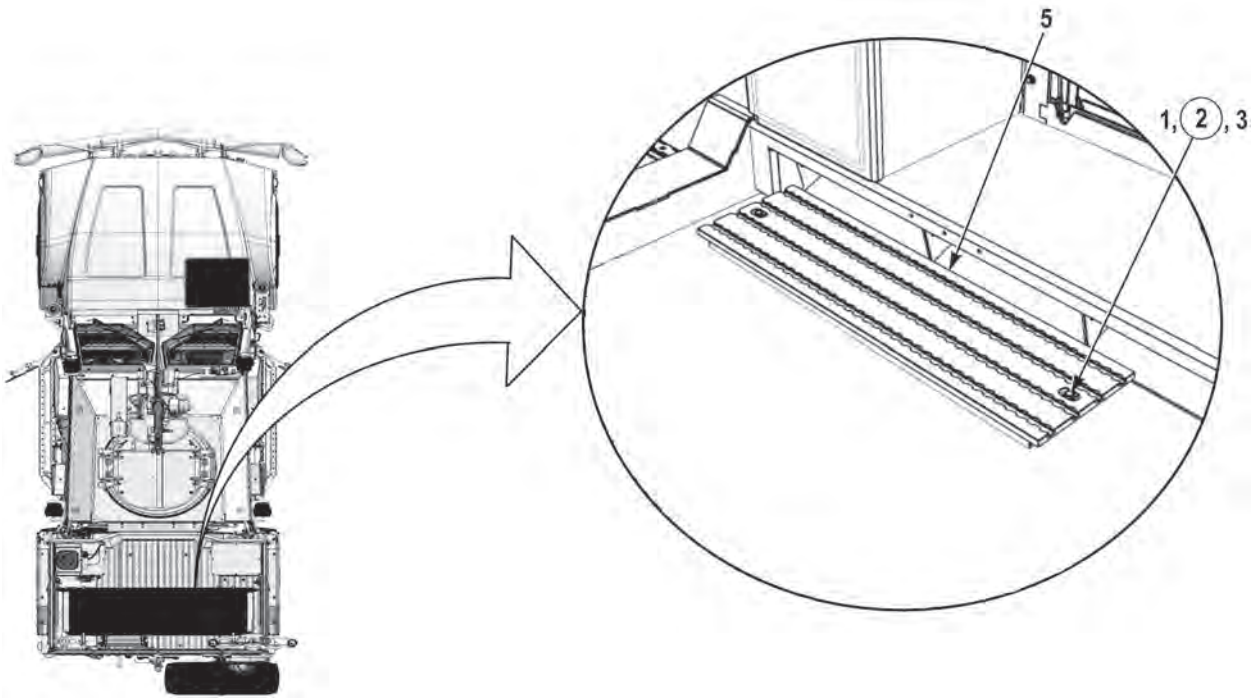

1. Remove two screws (1), two lockwashers (2), two washers (3), and passenger side battery box cover (4). Discard lockwashers (2).

**DISCONNECT – CONTINUED****NOTE**

- When removing terminal clamps from battery terminals, note position and location of connections prior to removal to ensure proper installation.
- All battery terminal clamps are disconnected the same way.

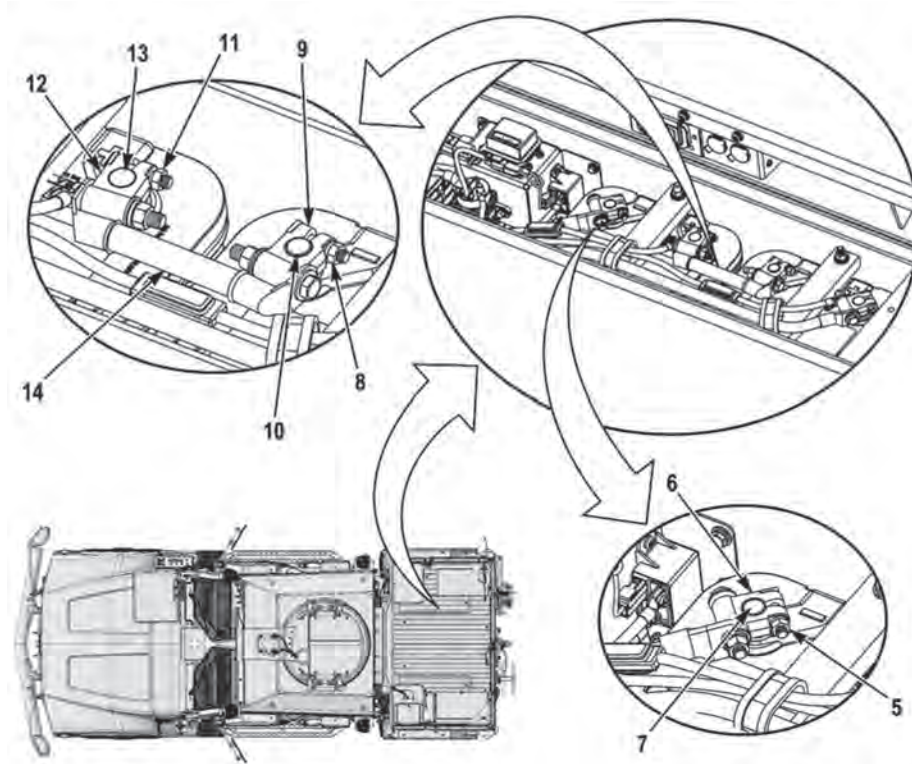

2. Loosen nut (5) on negative battery clamp (6).
3. Remove negative battery clamp (6) from negative battery terminal (7).
4. Loosen nut (8) on negative battery clamp (9).
5. Remove negative battery clamp (9) from negative battery terminal (10).
6. Loosen nut (11) on positive battery clamp (12).
7. Remove positive battery clamp (12) from positive battery terminal (13).
8. Remove center battery connecting cable (14) from battery compartment.

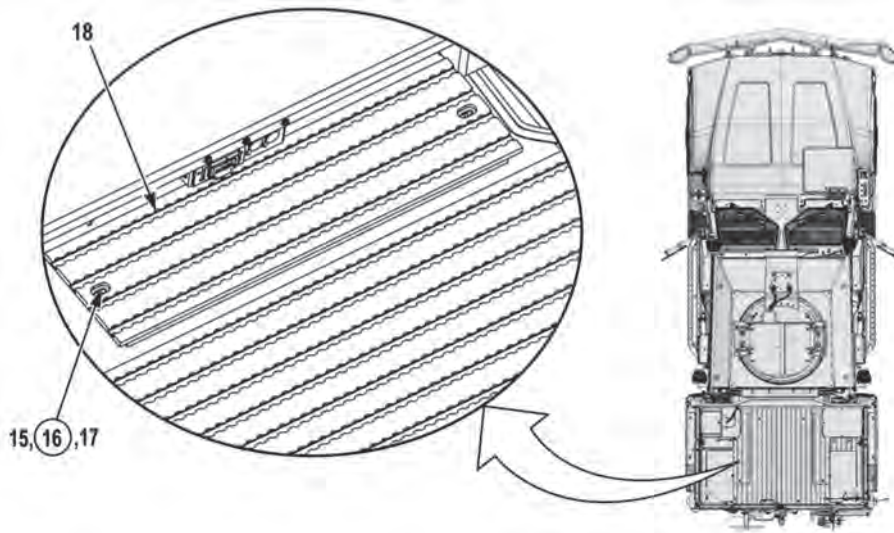
**DISCONNECT – CONTINUED**

9. Remove two screws (15), two lockwashers (16), two washers (17), and driver side battery box cover (18). Discard lockwashers (16).

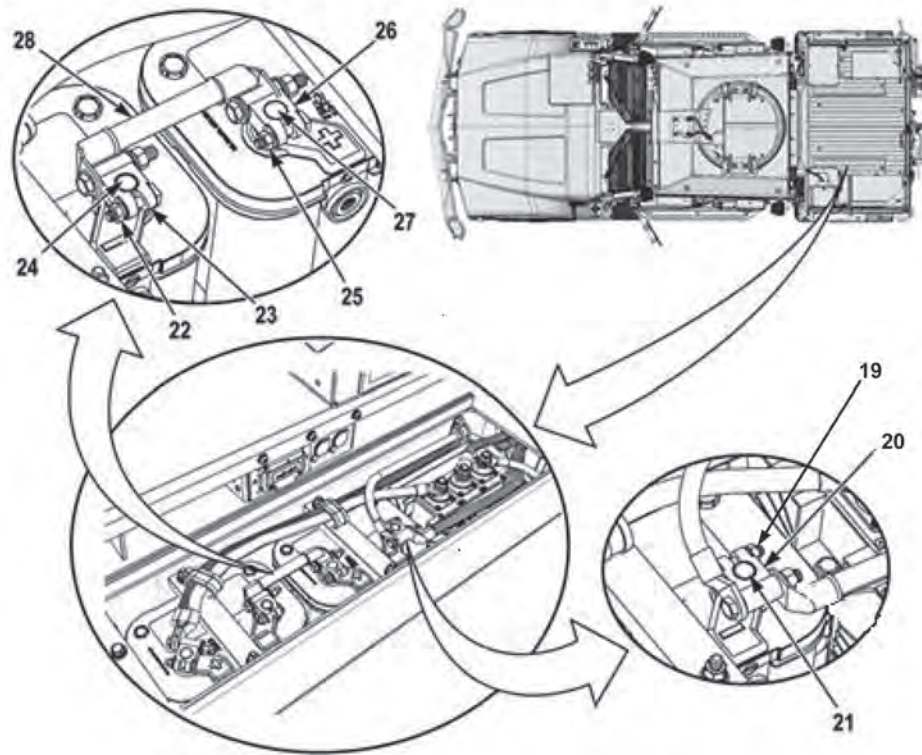
**DISCONNECT – CONTINUED**

10. Loosen nut (19) on negative battery clamp (20).
11. Remove negative battery clamp (20) from negative battery terminal (21).
12. Loosen nut (22) on negative battery clamp (23).
13. Remove negative battery clamp (23) from negative battery terminal (24).
14. Loosen nut (25) on positive battery clamp (26).
15. Remove positive battery clamp (26) from positive battery terminal (27).
16. Remove center battery connecting cable (28) from battery compartment.

**END OF TASK**

---

**CONNECT****WARNING**

- **Be careful not to short out battery terminal. Do not smoke or use open flame near batteries. Batteries may explode from spark. Failure to comply may result in injury or death to personnel.**
- **Lead-acid batteries contain sulfuric acid, which can cause severe burns. Avoid contact with skin, eyes, or clothing. Wear safety goggles and gloves. If battery electrolyte is spilled, take immediate action to stop its corrosive (burning) effects. If battery acid is spilled on clothing or vehicle, wash immediately with cold water. Neutralize with baking soda or household ammonia solution. If battery acid comes in contact with skin, flush with cold water to remove acid. If eyes are contacted, flush with cold water for at least 15 minutes. Seek immediate medical attention. If swallowed, drink large amounts of water or milk, follow with milk of magnesia, beaten egg, or vegetable oil. Seek immediate medical attention. Failure to comply may result in injury or death to personnel.**
- **Remove all jewelry, such as rings, dog tags, bracelets, etc. If jewelry contacts battery terminal or positive electrical circuit, a direct short may result in instant heating of tools, injury or death to personnel, or damage to equipment.**
- **To prevent arcing, do not allow tools to contact batteries or other battery terminals. Failure to comply may result in injury or death to personnel.**
- **Ensure batteries are disconnected when performing maintenance on or near batteries or electrical systems. Always remove negative battery terminals first. When reconnecting, always connect negative terminals last to avoid arcing or sparks that could cause an explosion.**

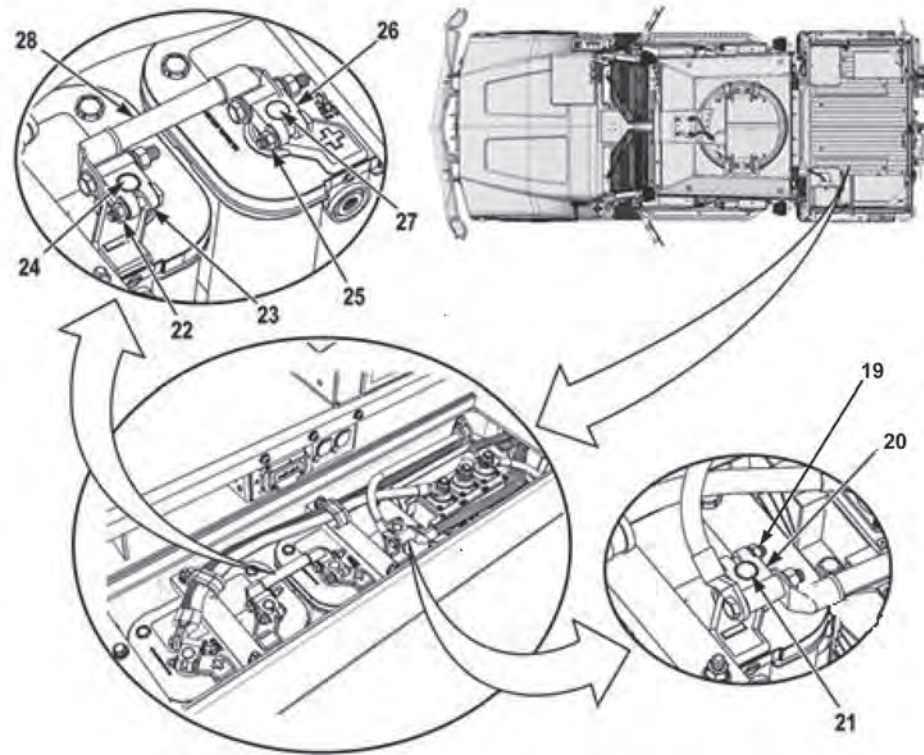

## CONNECT – CONTINUED

**NOTE**

- When installing terminal clamps on battery terminals, install as noted prior to removal to ensure proper installation.
  - All battery terminal clamps are connected the same way.
1. Position center battery connecting cable (28) in driver side battery compartment and connect positive battery clamp (26) on positive terminal (27) of front battery.
  2. Install rear battery negative clamp (23) on negative battery terminal (24).
  3. Tighten nuts (22 and 25) on battery clamps (23 and 26) to 84 – 96 lb-in (9.5 – 10.8 N·m).
  4. Install front battery negative clamp (20) on negative battery terminal (21).
  5. Tighten nut (19) on battery clamp (20) to 84 – 96 lb-in (9.5 – 10.8 N·m).
  6. Apply connector lubricant to battery terminals (21, 24, and 27) and battery clamps (20, 23, and 26).

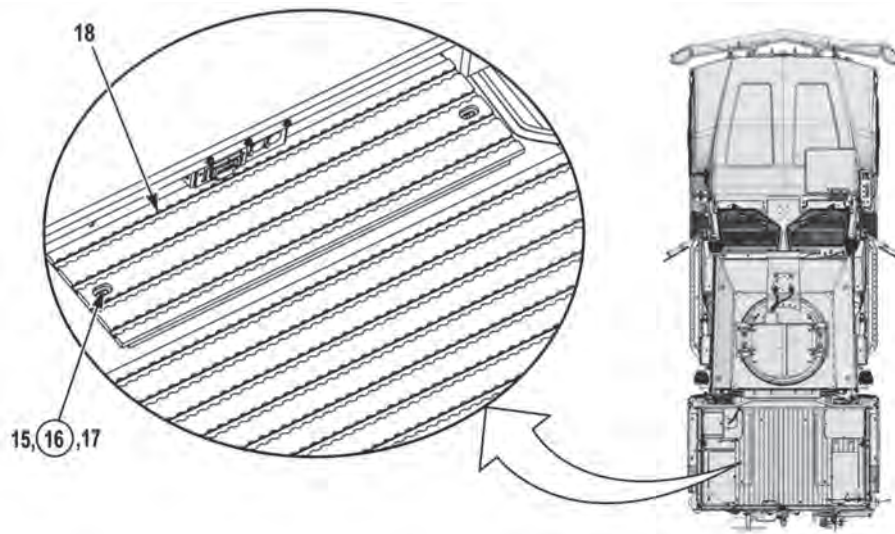
**CONNECT – CONTINUED**

7. Position driver side battery box cover (18) on cargo deck. Install two washers (17), two new lockwashers (16), and two screws (15).



## CONNECT – CONTINUED

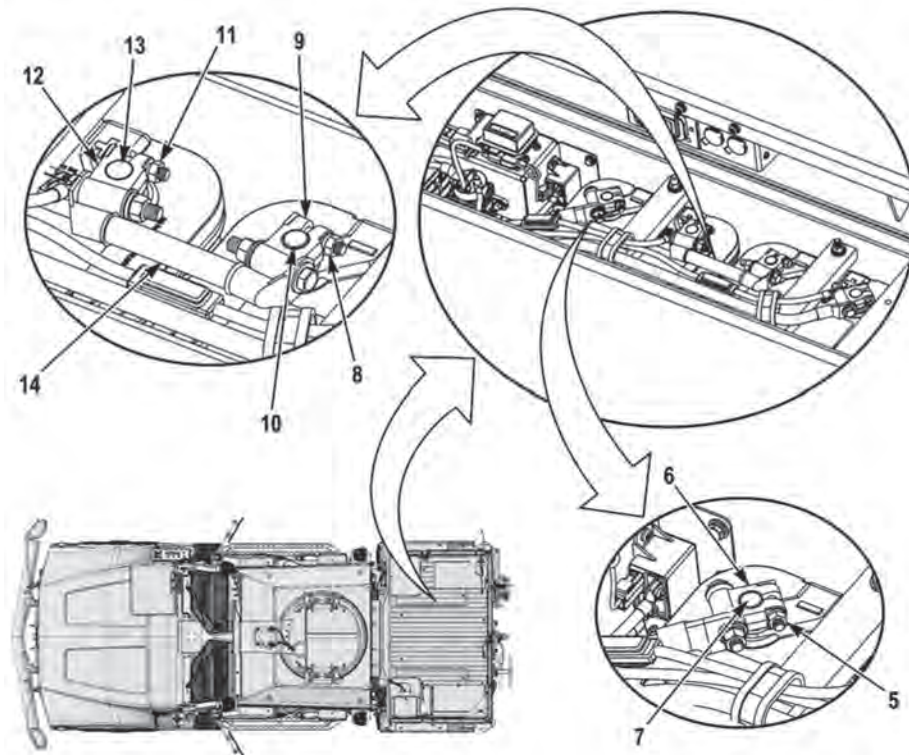

8. Position center battery connecting cable (14) in passenger side battery compartment and connect positive battery clamp (12) on positive terminal (13) of front battery.
9. Install rear battery negative clamp (9) on negative battery terminal (10).
10. Tighten nuts (8 and 11) on battery clamps (9 and 12) to 84 – 96 lb-in (9.5 – 10.8 N·m).
11. Install front battery negative clamp (6) on negative battery terminal (7).
12. Tighten nut (5) on battery clamp (6) to 84 – 96 lb-in (9.5 – 10.8 N·m).
13. Apply connector lubricant to battery terminals (7, 10, and 13) and battery clamps (6, 9, and 12).

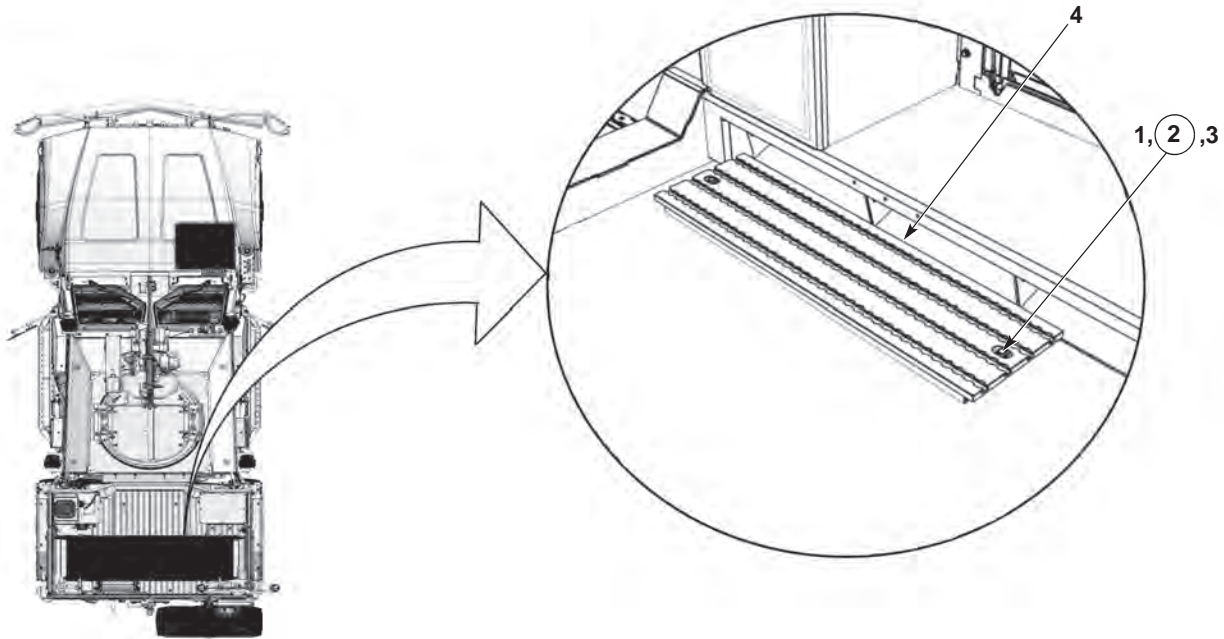
**CONNECT – CONTINUED**

14. Position passenger side battery box cover (4) on cargo deck. Install two washers (3), two new lockwashers (2), and two screws (1).
15. Perform all Follow-On Maintenance Tasks.

**END OF TASK****END OF WORK PACKAGE**

---

**BATTERY DISCONNECT SWITCH REPLACEMENT**

---

**Preconditions**

Park vehicle  
 Engine OFF  
 Wheels chocked  
 Batteries disconnected (M1240/M1240A1)  
 (WP 0186)  
 Batteries disconnected (M1245) (WP 0187)

**Tools and Special Tools**

Tool Kit, General Mechanic's: Automotive  
 Wrench, Torque, 40 to 200 in-lb

**Materials/Parts**

Locknut (4) (Item 1)  
 Lockwasher (3) (Item 12, 16, and 19)  
 Locknut (2) (Item 22)  
 Tags, Identification

**Follow-On Maintenance**

Connect batteries (M1240/M1240A1) (WP 0186)  
 Connect batteries (M1245) (WP 0187)  
 Remove and stow wheel chocks

---

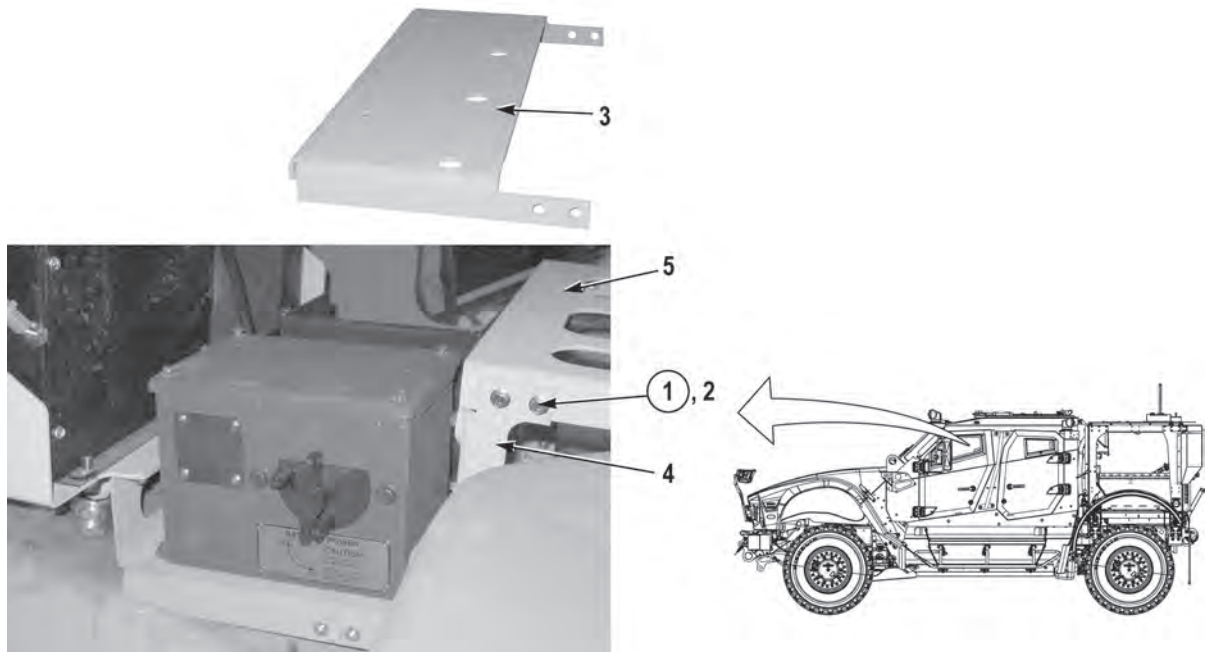
**REMOVAL**

1. Remove four locknuts (1), screws (2), and platform (3) from two brackets (4) and platform (5). Discard locknuts (1).

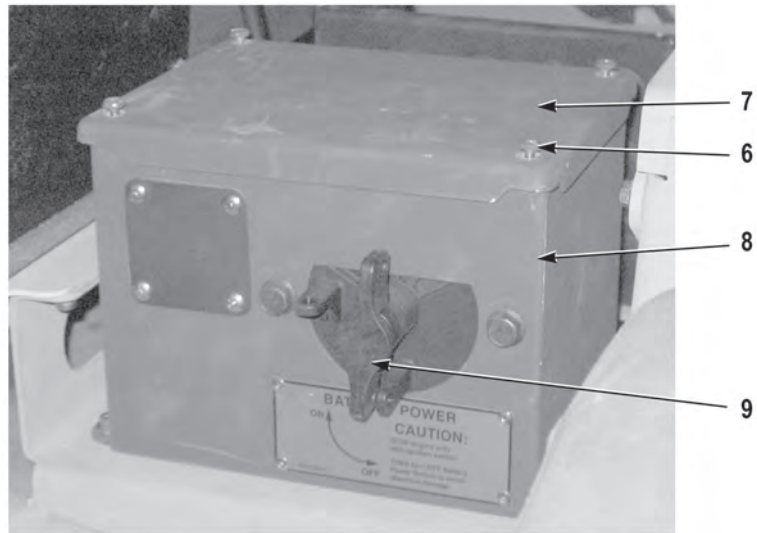

2. Remove four screws (6) and cover (7) from enclosure (8).

### NOTE

Note position of switch in relation to ON/OFF decal.

3. Turn battery disconnect switch (9) to ON position.

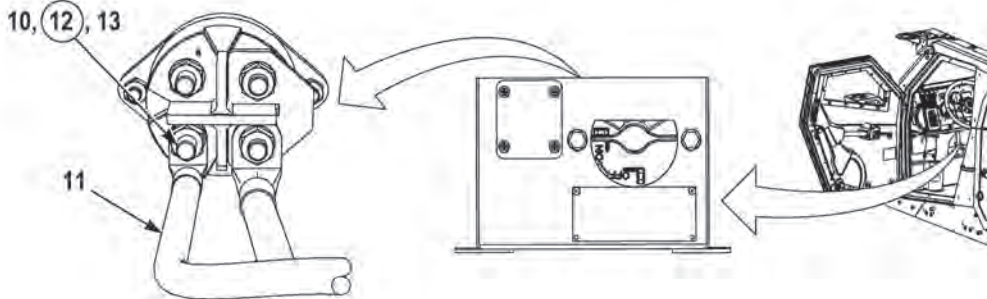

### NOTE

- Tag and mark wires prior to removal to ensure proper installation.

4. Remove nut (10), wire (11), and lockwasher (12) from stud (13). Discard lockwasher (12).

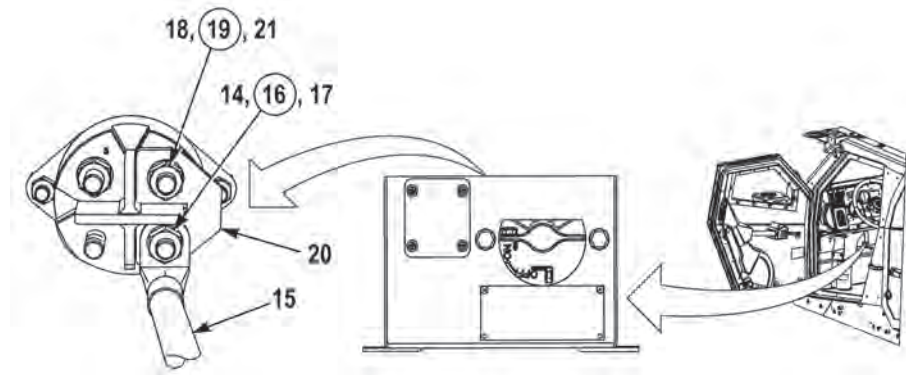

5. Remove nut (14), wire (15), and lockwasher (16) from stud (17). Discard lockwasher (16).
6. Remove nut (18), lockwasher (19), and busbar (20) from stud (21). Discard lockwasher (19).

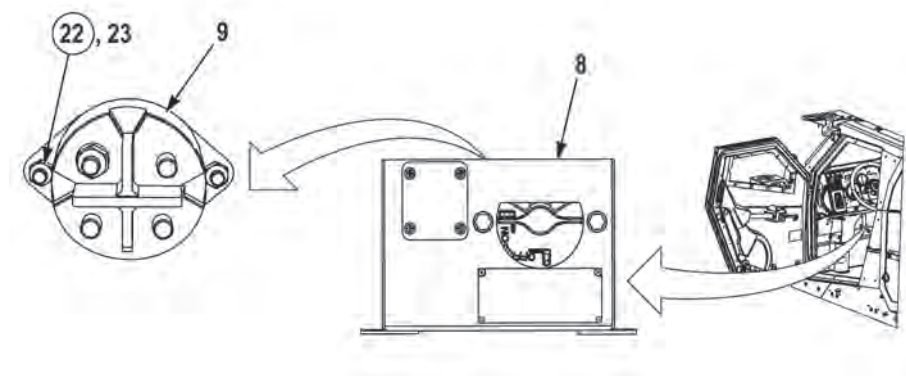

7. Remove two locknuts (22), screws (23), and battery disconnect switch (9) from enclosure (8). Discard locknuts (22).

#### END OF TASK

#### INSTALLATION

1. Install battery disconnect switch (9) on enclosure (8) with two screws (23) and new locknuts (22).
2. Install busbar (20) on stud (21) with new lockwasher (19) and nut (18). Tighten nut (18) to 14 lb-ft (19 N•m).
3. Install wire (15) on stud (17) with new lockwasher (16) and nut (14). Tighten nut (14) to 14 lb-ft (19 N•m).
4. Install wire (11) on stud (13) with new lockwasher (12) and nut (10). Tighten nut (10) to 14 lb-ft (19 N•m).

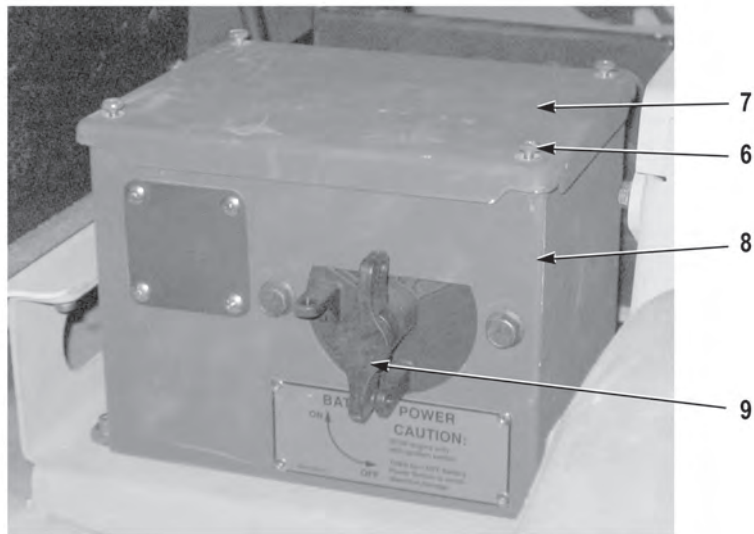

5. Turn battery disconnect switch (9) to ON position.
6. Install cover (7) on enclosure (8) with four screws (6).

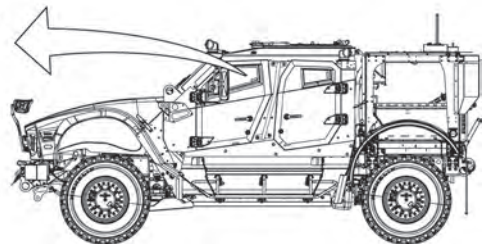
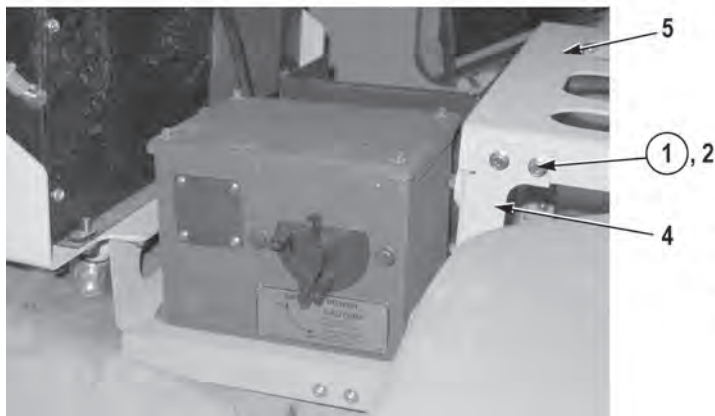

7. Install platform (3) on platform (5) and two brackets (4) with four screws (2) and new locknuts (1).
8. Perform all Follow-On Maintenance tasks.

**END OF TASK**

**END OF WORK PACKAGE**



---

**BATTERY ISOLATOR REPLACEMENT**

---

**Preconditions**

Park vehicle  
 Engine OFF  
 Wheels chocked  
 Batteries disconnected (M1240/M1240A1)  
 (WP 0186)  
 Batteries disconnected (M1245) (WP 0187)

**Tools and Special Tools**

Tool Kit, General Mechanic's: Automotive  
 Wrench, Torque, 0 to 300 in-lb

**Materials/Parts**

Lockwasher (3) (Item 2, 8, and 13)

**Materials/Parts (continued)**

Locknut (2) (Item 17)  
 Lockwasher (Item 23)  
 Sealant, RTV  
 Tags, Identification

**Personnel Required**

Two

**Follow-On Maintenance**

Connect batteries (M1240/M1240A1) (WP 0186)  
 Connect batteries (M1245) (WP 0187)  
 Remove and stow wheel chocks

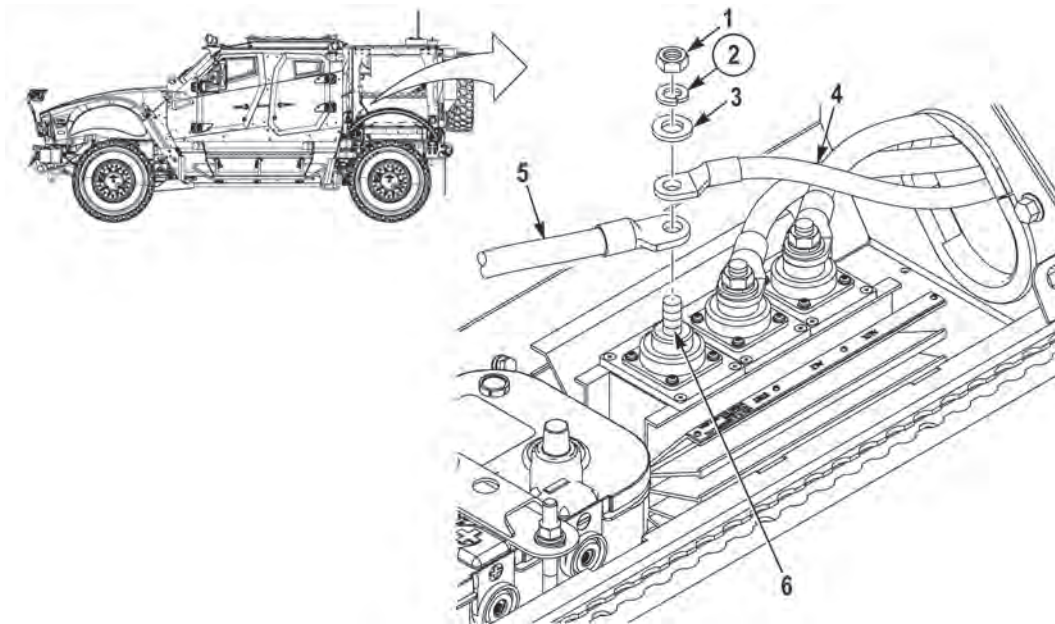
**REMOVAL****WARNING**

**All batteries must be disconnected prior to performing battery isolator removal. Failure to comply may result in injury or death to personnel.**

**NOTE**

- Tag and mark cables prior to removal to ensure proper installation.
  - Note position of cables prior to removal to ensure proper installation.
1. Remove nut (1), lockwasher (2), washer (3), cable (4), and cable (5) from STRT terminal (6). Discard lockwasher (2).

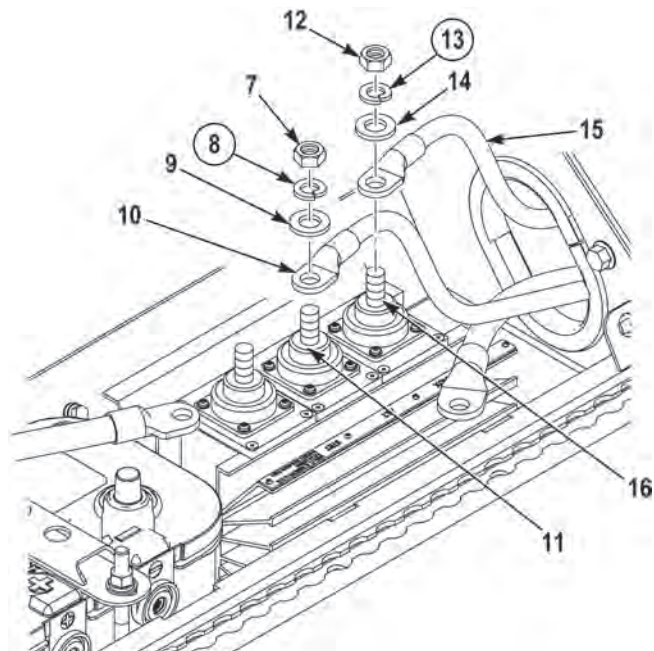

2. Remove nut (7), lockwasher (8), washer (9), and cable (10) from ALT terminal (11). Discard lockwasher (8).
3. Remove nut (12), lockwasher (13), washer (14), and cable (15) from AUX terminal (16). Discard lockwasher (13).

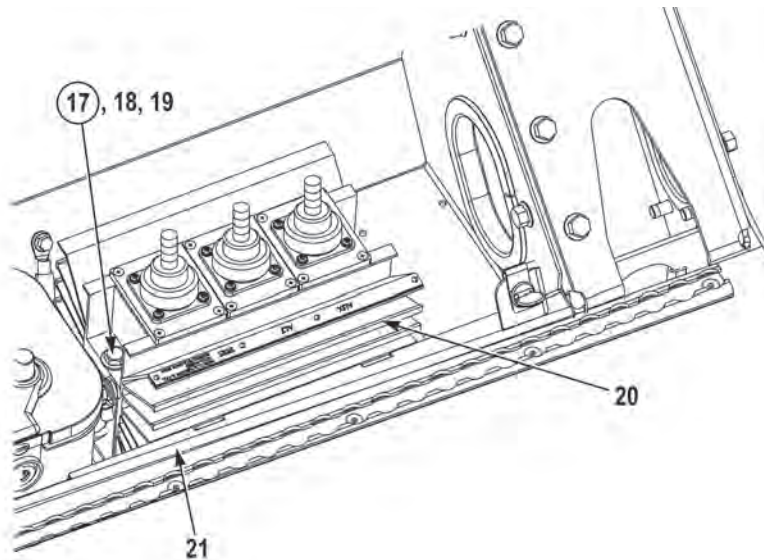

#### NOTE

- Note position of battery isolator prior to removal to ensure proper installation.
  - Battery isolator is not being removed from the vehicle in Step (4).
4. With the aid of an assistant, remove two locknuts (17), screws (18), washers (19), and battery isolator (20) from battery box (21). Discard locknuts (17).



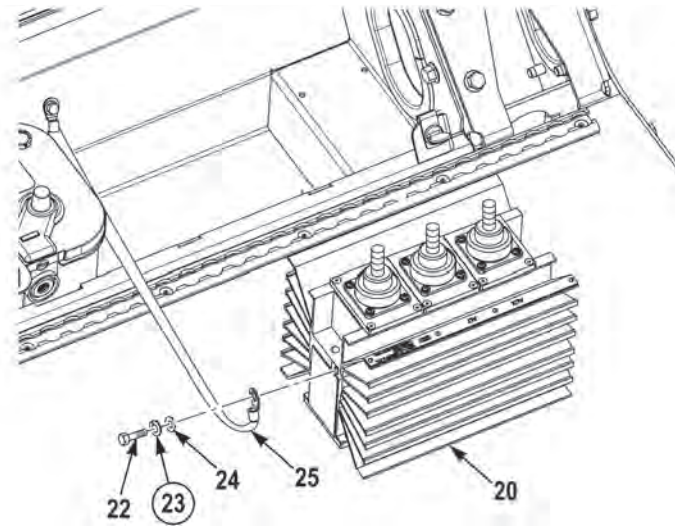

5. Remove screw (22), lockwasher (23), washer (24), and ground strap (25) from battery isolator (20). Discard lockwasher (23).
6. Remove battery isolator (20) from vehicle.

#### END OF TASK

#### INSTALLATION

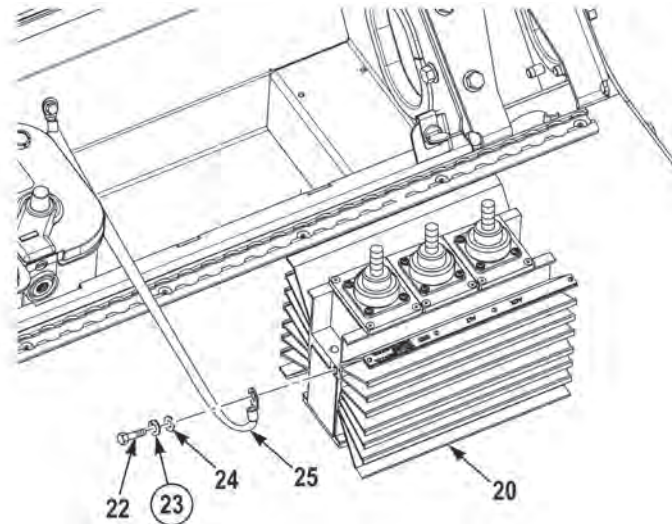

#### NOTE

Ensure mating surface of battery isolator and ground strap is clean, bare metal prior to installation.

1. Install ground strap (25) on battery isolator (20) with washer (24), new lockwasher (23), and screw (22). Tighten screw (22) to 133 lb-in (15 N•m).

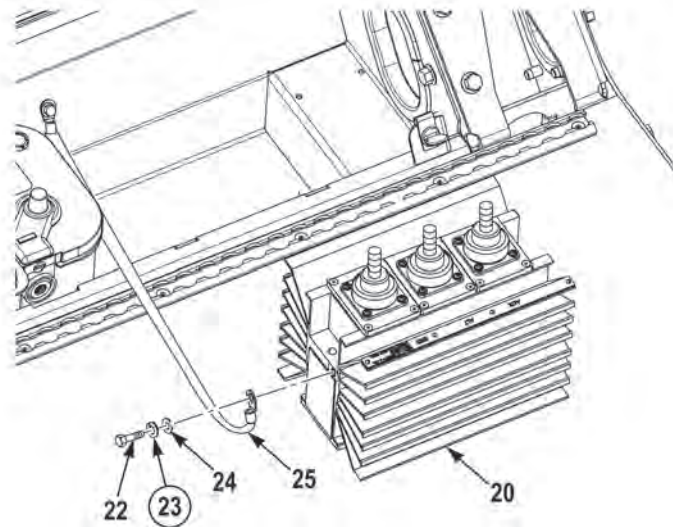

### **WARNING**

Adhesives, solvents, and sealing compounds can burn easily, can give off harmful vapors, and are harmful to skin and clothing. To avoid injury or death, keep away from open fire and use in well-ventilated area. If adhesive, solvent, or sealing compound gets on skin or clothing, wash immediately with soap and water. Failure to comply may result in injury or death to personnel.

2. Apply sealant RTV, to head of screw (22), new lockwasher (23), washer (24), and ground strap (25).

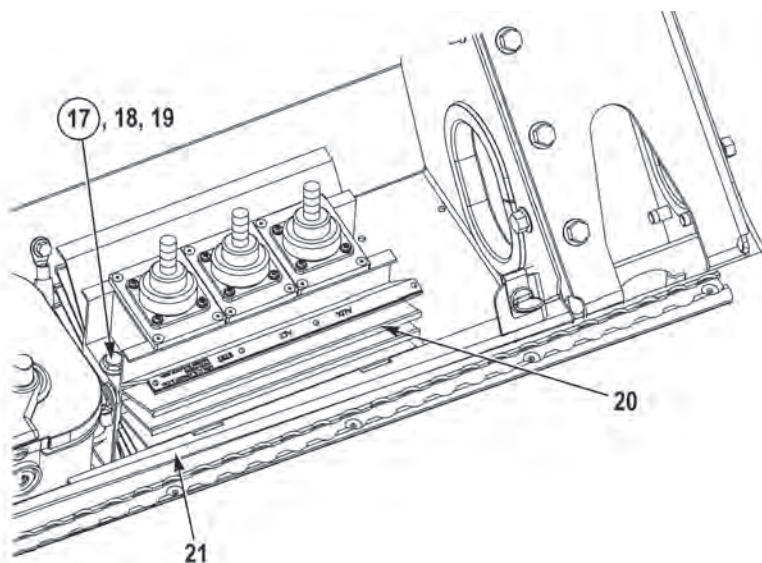

### **NOTE**

Install battery isolator as noted prior to removal.

3. Position battery isolator (20) in battery box (21).

4. With the aid of an assistant, secure battery isolator (20) in battery box (21) with two washers (19), screws (18), and new locknuts (17).

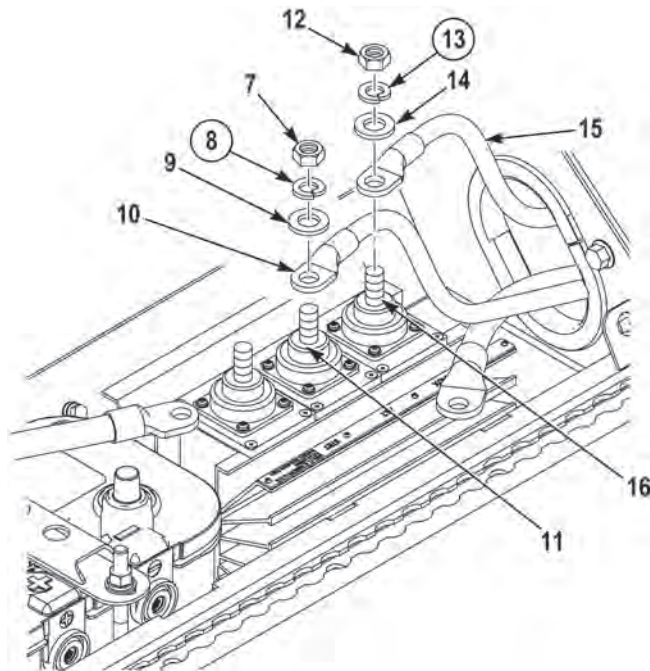

### NOTE

Install cables as noted prior to removal.

5. Install cable (15) on AUX terminal (16) with washer (14), new lockwasher (13), and nut (12). Tighten nut (12) to 265 lb-in (30 N•m).
6. Install cable (10) on ALT terminal (11) with washer (9), new lockwasher (8), and nut (7). Tighten nut (7) to 265 lb-in (30 N•m).

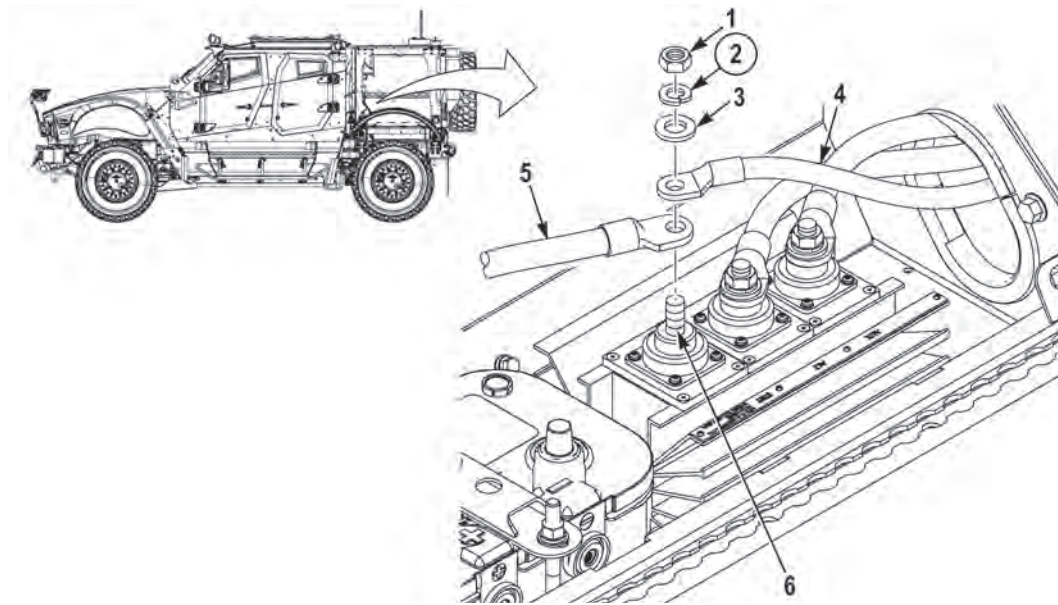

7. Install cable (5) and cable (4) on STRT terminal (6) with washer (3), new lockwasher (2), and nut (1). Tighten nut (1) to 265 lb-in (30 N•m).

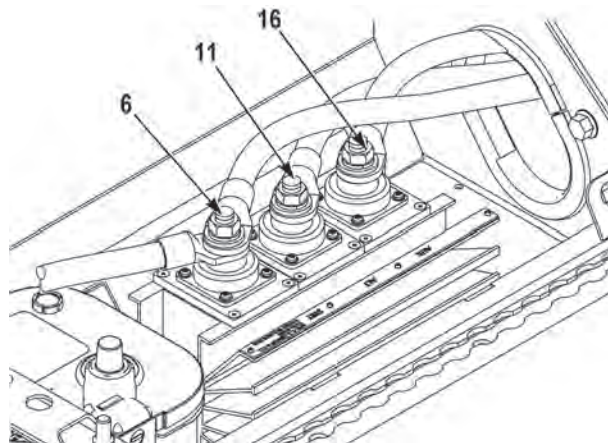

### **WARNING**

Adhesives, solvents, and sealing compounds can burn easily, can give off harmful vapors, and are harmful to skin and clothing. To avoid injury or death, keep away from open fire and use in well-ventilated area. If adhesive, solvent, or sealing compound gets on skin or clothing, wash immediately with soap and water. Failure to comply may result in injury or death to personnel.

8. Apply sealant RTV, to STRT terminal (6), ALT terminal (11), an AUX terminal (16).
9. Perform all Follow-On Maintenance tasks.

**END OF TASK**

**END OF WORK PACKAGE**



---

**BATTERY PDU BOX REPLACEMENT (M1245)**

---

**Preconditions**

Park Vehicle  
 Engine OFF  
 Wheels Chocked  
 Batteries Disconnected (WP 0187)

**Tools and Special Tools**

Tool Kit, General Mechanic's: Automotive

**Materials/Parts**

Adhesive - Sealant, Silicone, RTV  
 Lockwasher (4) (Item 15)

**Follow-On Maintenance**

Connect batteries (WP 0187)  
 Remove and Stow Wheel Chocks

---

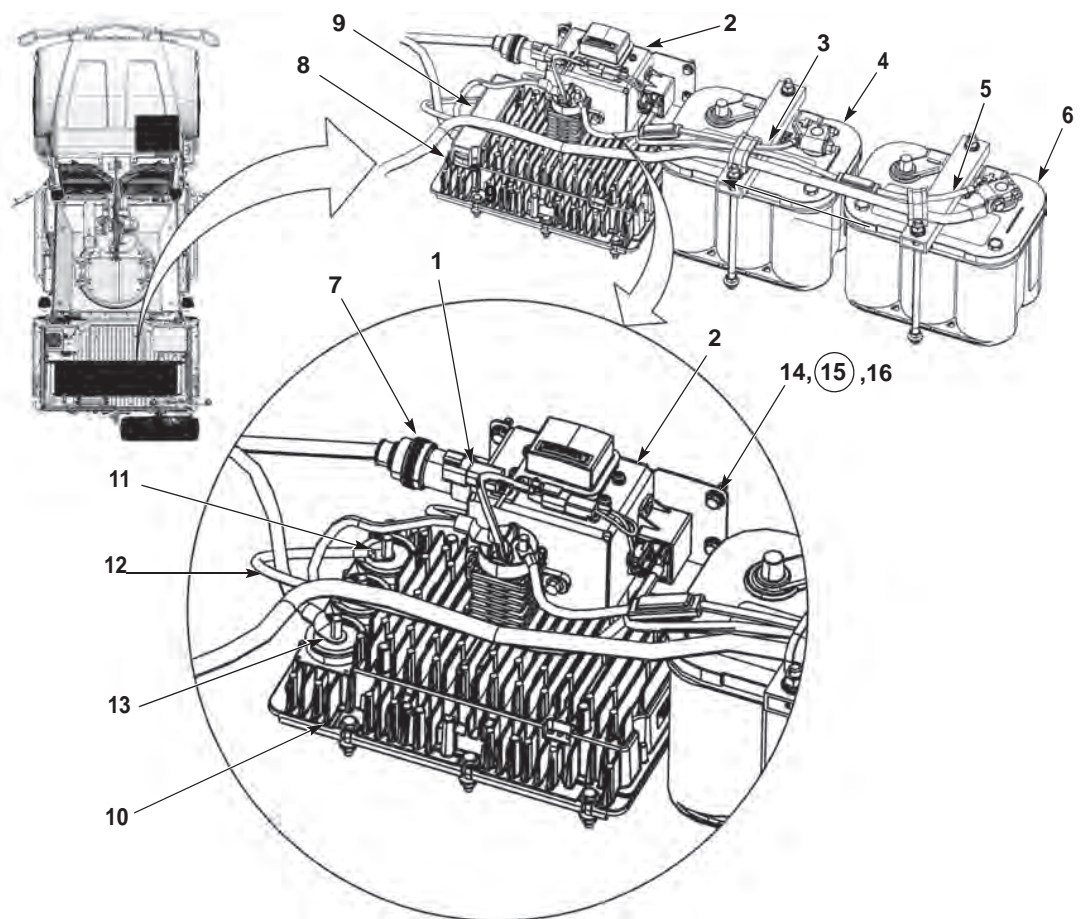
**REMOVAL****NOTE**

- Truck shown removed for clarity.
- Tag and mark wires and connectors and note all wire harness routing prior to removal to ensure proper installation.
- Remove cable ties as required

1. Disconnect electrical connector (1) from the PDU (2).

## REMOVAL – CONTINUED

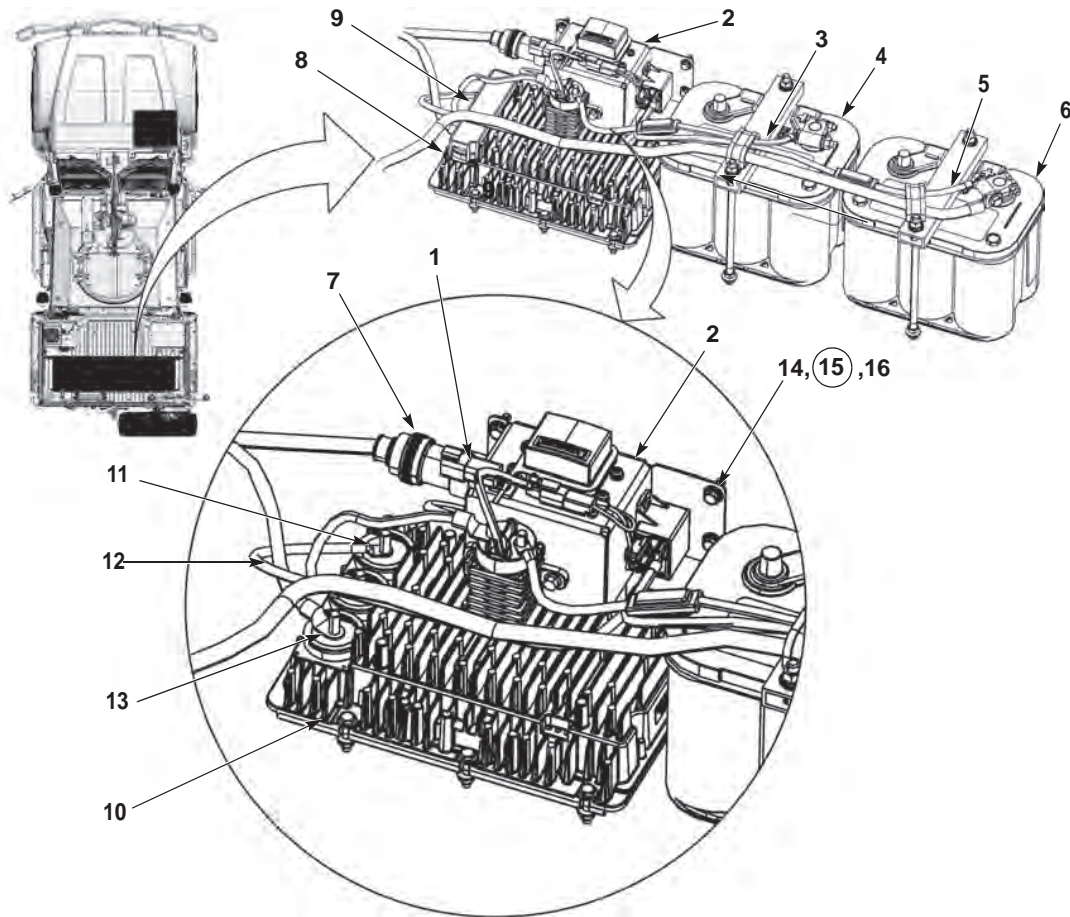

2. Disconnect cable 1973 (3) from the positive terminal of the forward battery (4).
3. Disconnect cable 1141 (5) from the positive terminal of the rear battery (6).
4. Disconnect the electrical connector (7) from the PDU (2).
5. Remove four screws (8) and remove cover (9) from equalizer (10).
6. Remove cables 1141A (11), 1973A (12) and BLK GND wire (13) from equalizer (10).
7. Remove four screws (14), four lockwashers (15), four washers (16) and remove PDU (2). Discard lockwashers (15).

**END OF TASK**

## INSTALLATION

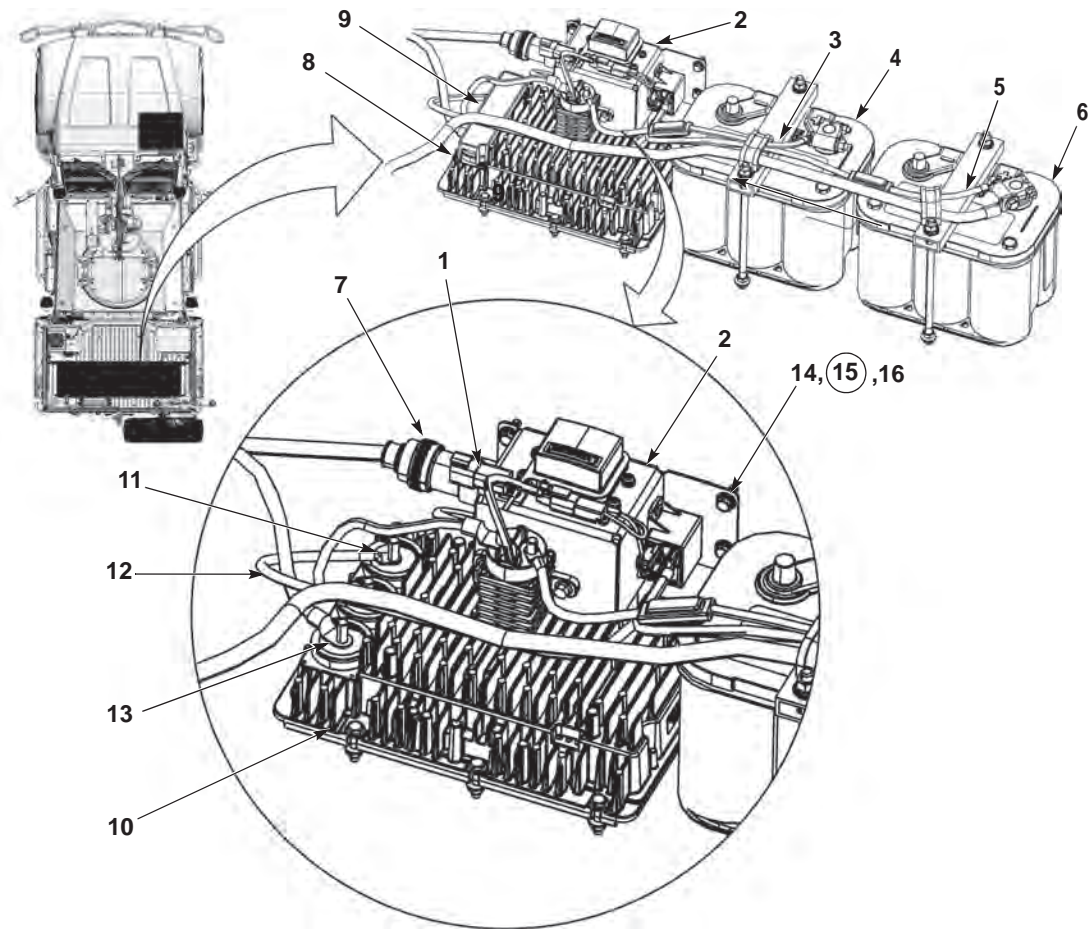

## NOTE

- Truck shown removed for clarity.
  - Install cable ties as required.
1. Position the battery PDU box (2) in passenger side battery compartment.
  2. Install four washers (16), four new lockwashers (15), and four screws (14).
  3. Connect cables 1141A (11), 1973A (12) and BLK GND wire (13) to equalizer (10).

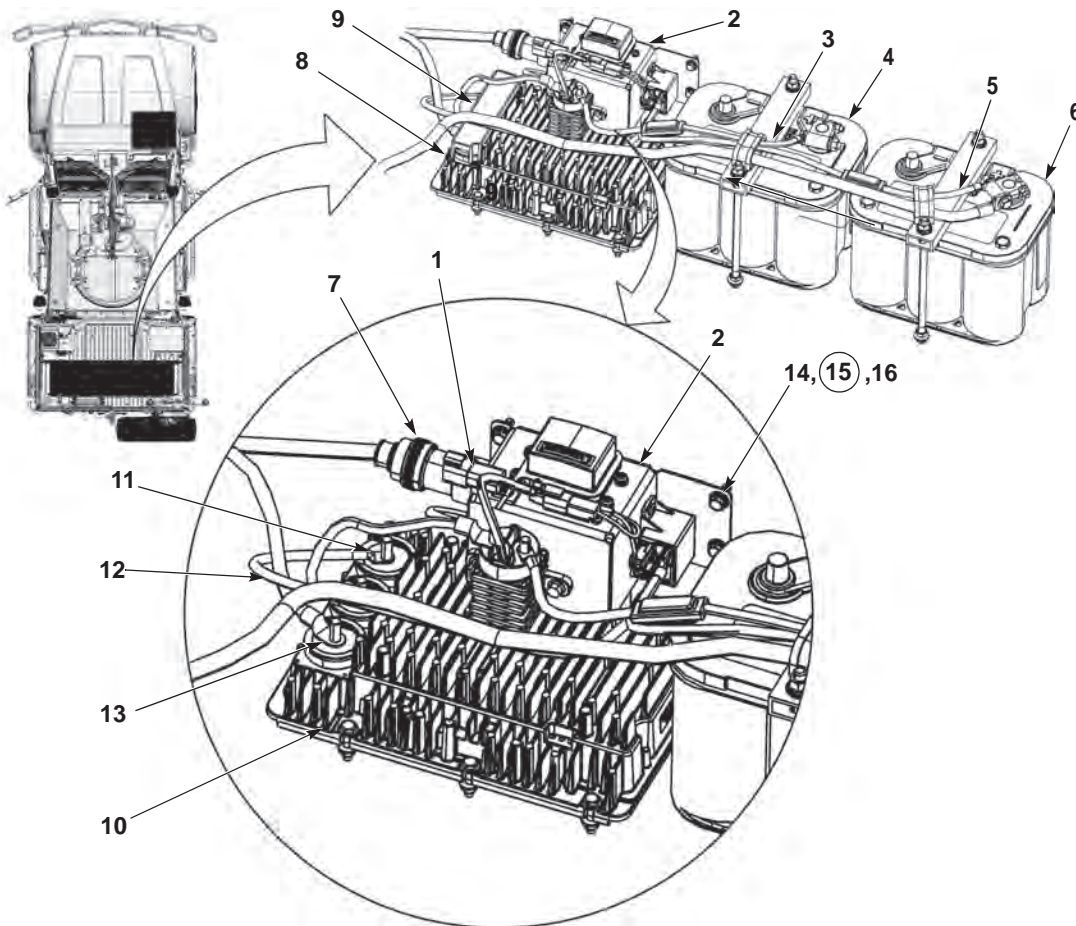

**INSTALLATION – CONTINUED****NOTE**

- Truck shown removed for clarity.
  - Install cable ties as required.
4. Apply RTV sealant to connectors for cables 1141A (11), 1973A (12) and BLK GND wire (13).
  5. Position cover (9) on equalizer (10) and install four screws (8).
  6. Connect electrical connector (7) to PDU (2).
  7. Connect cable 1141 (5) to positive terminal of rear battery (6).
  8. Connect cable 1973 (3) from the positive terminal of the forward battery (4).
  9. Connect electrical connector (1) to PDU (2).
  10. Perform all Follow-On Maintenance Tasks.

**END OF TASK****END OF WORK PACKAGE**



---

**BATTERY REPLACEMENT (M1240/M1240A1)**

---

**Preconditions**

Park vehicle  
Engine OFF  
Wheels chocked

**Tools and Special Tools**

Crowfoot, Flare Nut, 3/8 Dr., 1/2 in.  
Puller, Cable Clamp  
Socket, Universal, 12P, 9/16 in., 3/8 Drive  
Tool Kit, General Mechanic's: Automotive  
Wrench, Torque, 0 to 300 in-lb

**Materials/Parts**

Lockwasher (Item 5)  
Lockwasher (2) (Item 18)  
Lubricant, Connector  
Ties, Cable

**Follow-On Maintenance**

Remove and stow wheel chocks

---

**REMOVAL****WARNING**

- Use extreme care not to short out battery terminals. Remove all jewelry such as rings, ID tags, bracelets, etc. prior to working on or around vehicle. Jewelry and tools can catch on equipment, contact positive electrical circuits, and cause severe burns or electrical shock. Failure to comply may result in injury or death to personnel.
- Upon removal of terminal clamps, avoid accidental contact between terminal clamps and battery terminals. This will prevent accidental shorting, arcing, or sparks. Secure terminal clamps, cables, and wires away from battery terminals with cable ties as required. Failure to comply may result in injury or death to personnel.
- Do not smoke, have open flame, or cause sparks near batteries. Batteries may explode. Failure to comply may result in injury or death to personnel.
- Battery acid is harmful to skin and eyes. Always wear safety goggles, acid-proof gloves, and a rubber apron when performing battery maintenance. Failure to comply may result in injury or death to personnel.
- Avoid electrolyte contact with skin and eyes. Failure to comply may result in injury or death to personnel.

**CAUTION**

- When removing and installing battery terminals and cables from batteries, ensure they are removed and installed in proper sequence as described below. Failure to comply may result in damage to equipment.
- Ensure battery disconnect switch is turned OFF prior to performing battery maintenance. Failure to comply may result in damage to equipment.

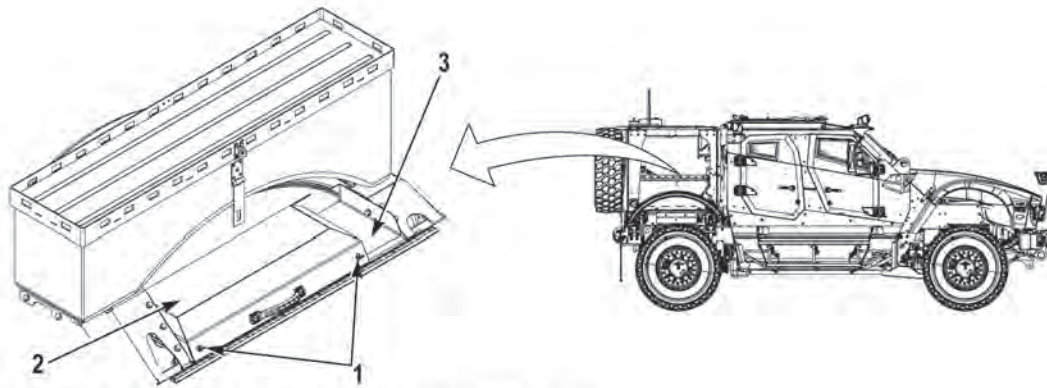

ANTENNA PLATFORM SHOWN REMOVED FOR CLARITY

### NOTE

- Two batteries are located in the cargo deck, on the driver side, used to start vehicle.
- Two batteries are located in the cargo deck, on the passenger side, used to power GFE in silent watch operations.
- The battery cases are marked with a (+) positive and/or a (-) negative to help identify battery polarity.
- When removing terminal clamps, note position and location of connections prior to their removal to ensure proper installation.
- All battery terminal clamps are removed the same way except where noted. Passenger side shown.

1. Remove two thumbscrews (1) and battery cover (2) from cargo deck (3).

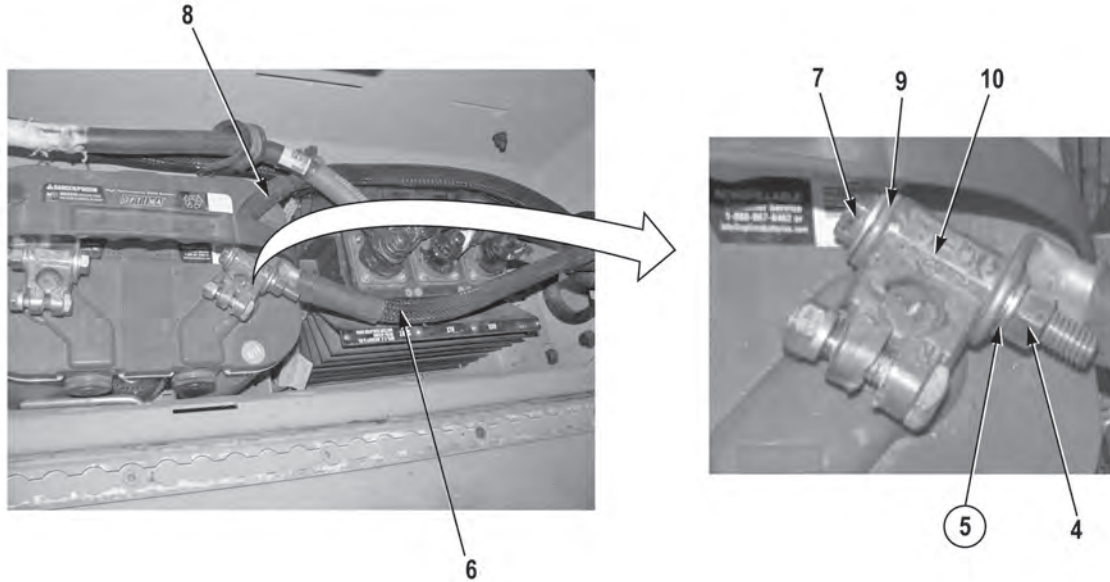

### NOTE

Perform Step (2) if removing driver side front battery.

2. Remove nut (4), lockwasher (5), cable (6), screw (7), cable (8), and washer (9) from terminal clamp (10). Discard lockwasher (5).

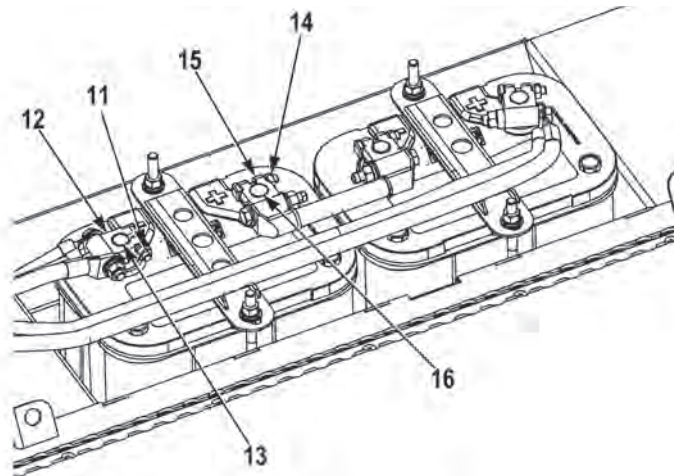

3. Loosen nut (11) on terminal clamp (12).
4. Using cable clamp puller, remove terminal clamp (12) from negative battery terminal (13).
5. Loosen nut (14) on terminal clamp (15).
6. Using cable clamp puller, remove terminal clamp (15) from positive battery terminal (16).

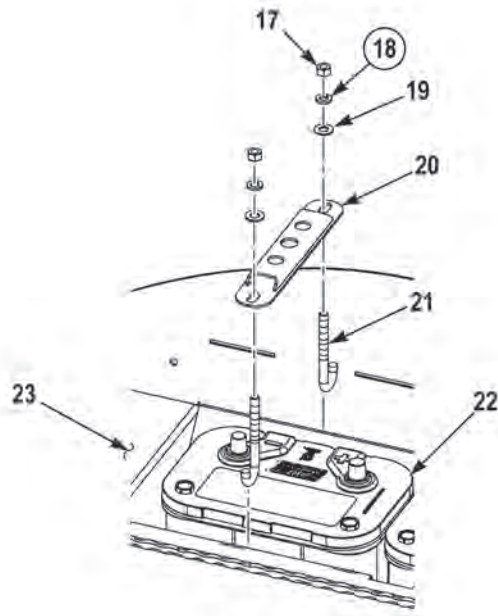
**NOTE**

- Driver side batteries will have two cushion clips.
- Note position of cushion clips prior to removal to ensure proper installation.

7. Remove two nuts (17), lockwashers (18), washers (19), and battery hold down bracket (20) from two J-hooks (21) and battery (22). Discard lockwashers (18).

**NOTE**

Note position of battery prior to removal to ensure proper installation.

8. Remove battery (22) from battery box (23).
9. Remove two J-hooks (21) from battery box (23).

**END OF TASK**

---

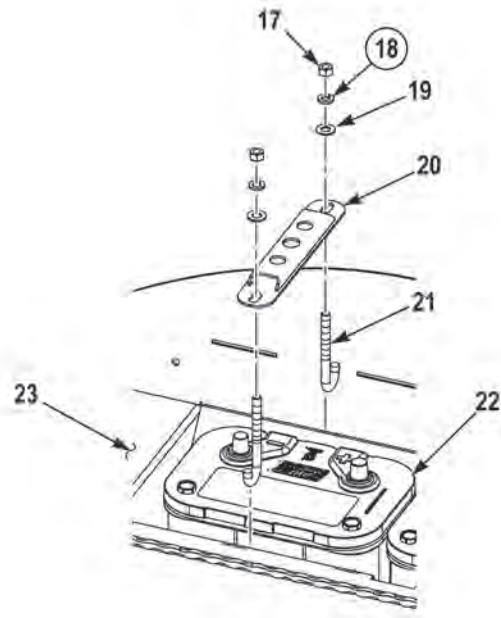
**INSTALLATION**

1. Position two J-hooks (21) in battery box (23).

**NOTE**

Install battery as noted prior to removal.

2. Install battery (22) in battery box (23).

**NOTE**

- Driver side batteries will have two cushion clips.
  - Install cushion clips as noted prior to removal.
3. Secure battery (22) in battery box (23) with two J-hooks (21), battery hold down bracket (20), two washers (19), new lockwashers (18), and nuts (17). Tighten nuts (17) to 20 to 30 lb-in (2 to 3 N•m).

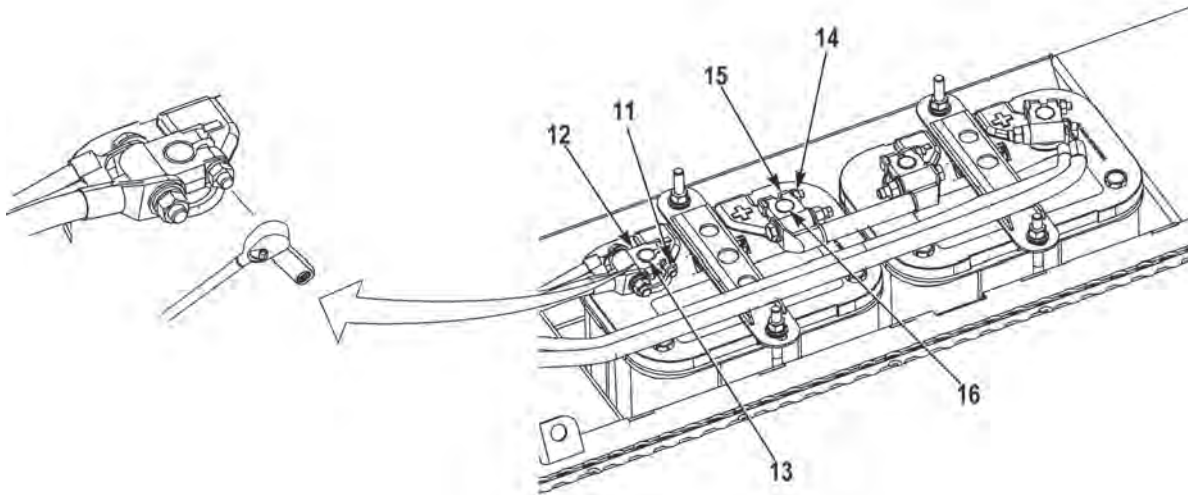

### **CAUTION**

**While tightening nuts, hold screws with wrench. Failure to comply may result in damage to equipment.**

### **NOTE**

- All battery terminals are connected the same way except where noted. Front passenger side shown.
  - Install terminal clamps as noted prior to removal.
  - Ensure torque wrench is 90° to crowfoot when torquing terminal clamps.
4. Install terminal clamp (15) on positive battery terminal (16) with nut (14). Tighten nut (14) to 84 to 96 lb-in (9 to 11 N•m).
  5. Install terminal clamp (12) on negative battery terminal (13) with nut (11). Tighten nut (11) to 84 to 96 lb-in (9 to 11 N•m).

### **WARNING**

**Adhesives, solvents, and sealing compounds can burn easily, can give off harmful vapors, and are harmful to skin and clothing. To avoid injury or death, keep away from open fire and use in well-ventilated area. If adhesive, solvent, or sealing compound gets on skin or clothing, wash immediately with soap and water. Failure to comply may result in injury or death to personnel.**

6. Apply connector lubricant to terminal clamp (15), positive battery terminal (16), terminal clamp (1), and negative battery terminal (12).



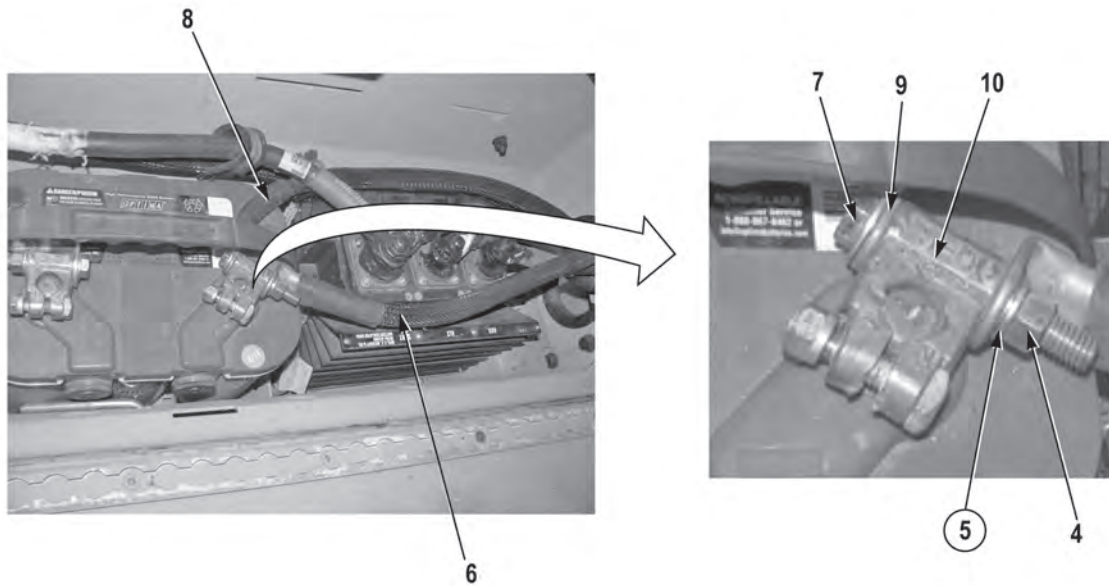

### NOTE

Perform Step (7) if driver side front battery was removed.

7. Install washer (9), cable (8), screw (7), cable (6), new lockwasher (5), and nut (4) on terminal (10). Tighten nut (4) to 84 to 96 lb-in.

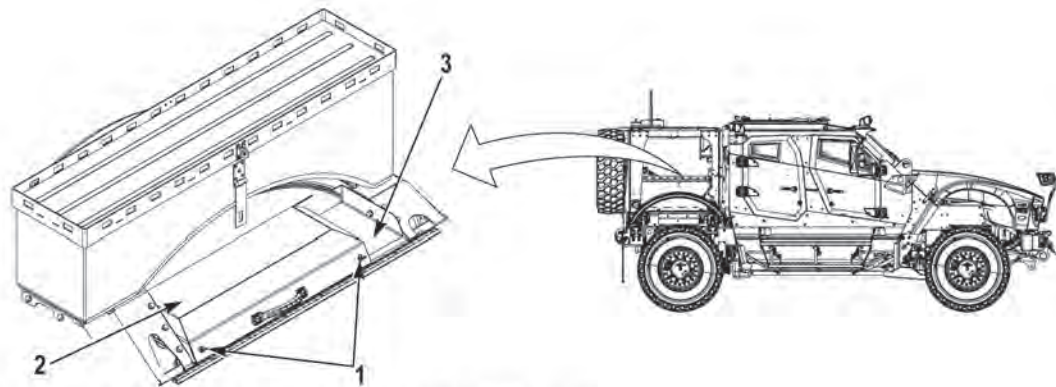

ANTENNA PLATFORM SHOWN REMOVED FOR CLARITY

8. Install battery cover (2) on cargo deck (3) with two thumbscrews (1).
9. Perform all Follow-On Maintenance tasks.

**END OF TASK**

**END OF WORK PACKAGE**





---

**BLACKOUT DRIVELIGHT REPLACEMENT**

---

**Preconditions**

Park vehicle  
 Engine OFF  
 Wheels chocked  
 Batteries disconnected (M1240/1240A1)  
 (WP 0186)  
 Batteries disconnected (M1245) (WP 0187)

**Tools and Special Tools**

Tool Kit, General Mechanic's: Automotive

**Materials/Parts**

Locknut (3) (Item 1)  
 Compound, Corrosion Preventive, Ultra Tef-Gel  
 05SA2  
 Lubricant, Connector, Nyogel 760G  
 Tags, Identification

**Follow-On Maintenance**

Connect batteries (M1240/M1240A1) (WP 0186)  
 Connect batteries (M1245) (WP 0187)  
 Remove and stow wheel chocks

---

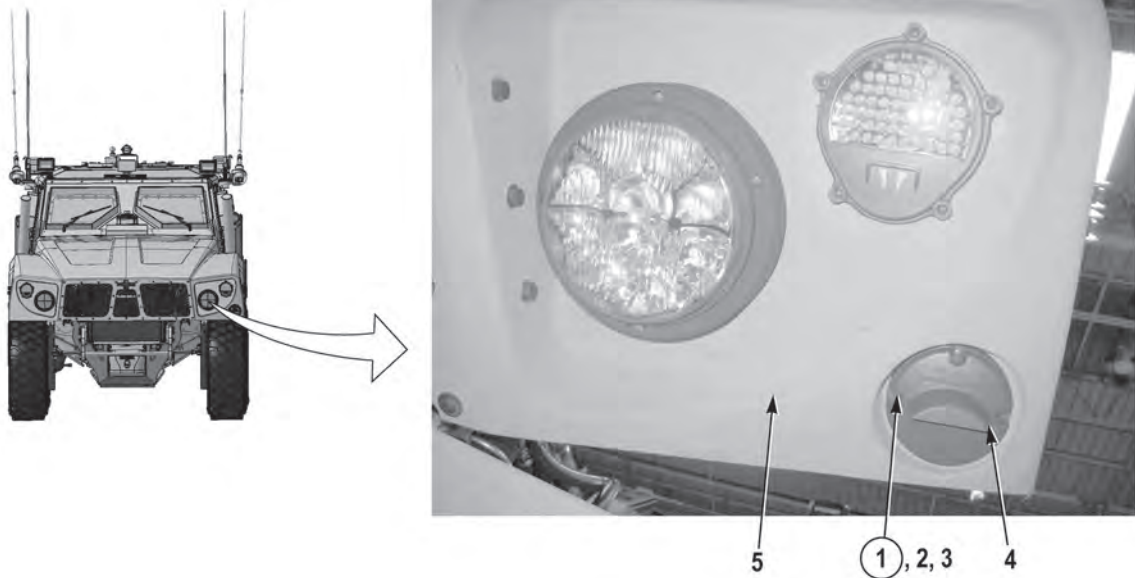
**REMOVAL****NOTE**

Tag and mark wires prior to removal to ensure proper installation.

1. Remove three locknuts (1), screws (2), washers (3), and blackout drivelight (4) from hood (5). Discard locknuts (1).

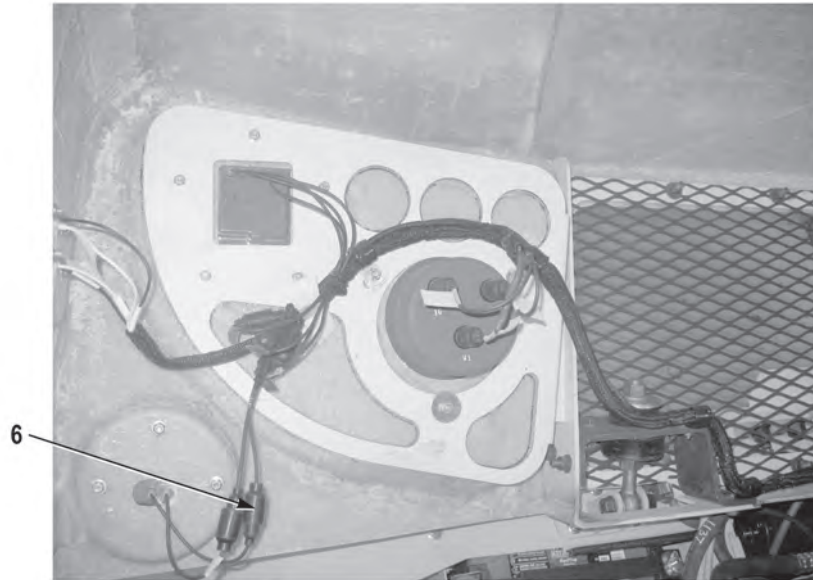

2. Disconnect two connectors (6).

#### END OF TASK

#### INSTALLATION

#### NOTE

Install wires as noted prior to removal to ensure proper installation.

1. Connect two connectors (6).

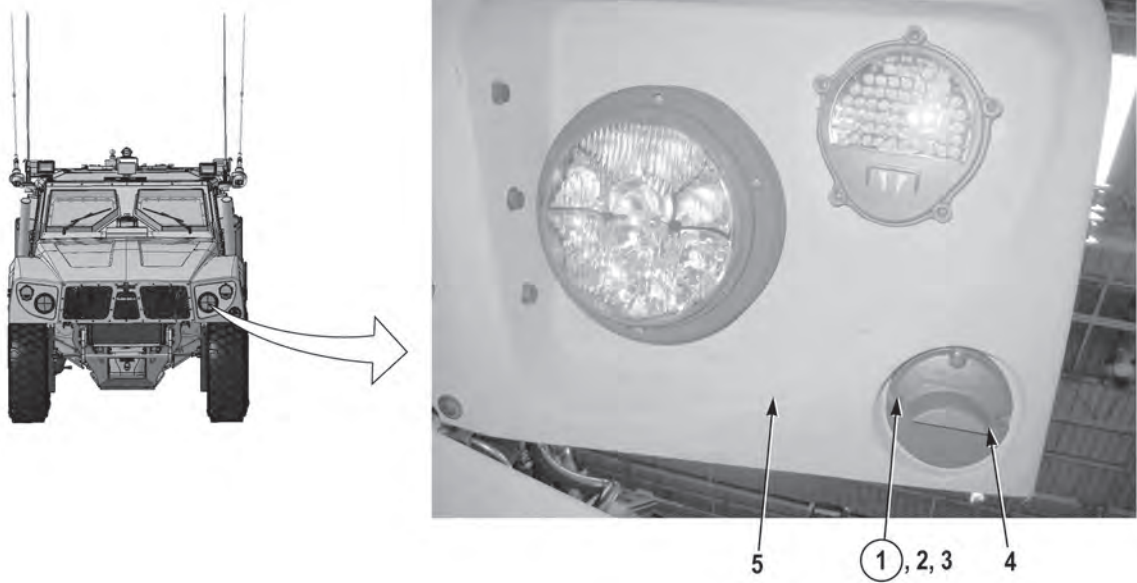

2. Install blackout drivelight (4) on hood (5) with two screws (2), washers (3) and new locknuts (1).
3. Perform all Follow-On Maintenance tasks.

**END OF TASK**

**END OF WORK PACKAGE**



---

**CHECK-6 REAR COMPOSITE LIGHT REPLACEMENT**

---

**Preconditions**

Park vehicle  
 Engine OFF  
 Wheels chocked  
 Batteries disconnected (M1240/M1240A1)  
 (WP 0186)  
 Batteries disconnected (M1245) (WP 0187)

**Materials/Parts**

Tags, Identification

**Follow-On Maintenance**

Connect batteries (M1240/M1240A1) (WP 0186)  
 Connect batteries (M1245) (WP 0187)  
 Remove and stow wheel chocks

**Tools and Special Tools**

Tool Kit, General Mechanic's: Automotive

---

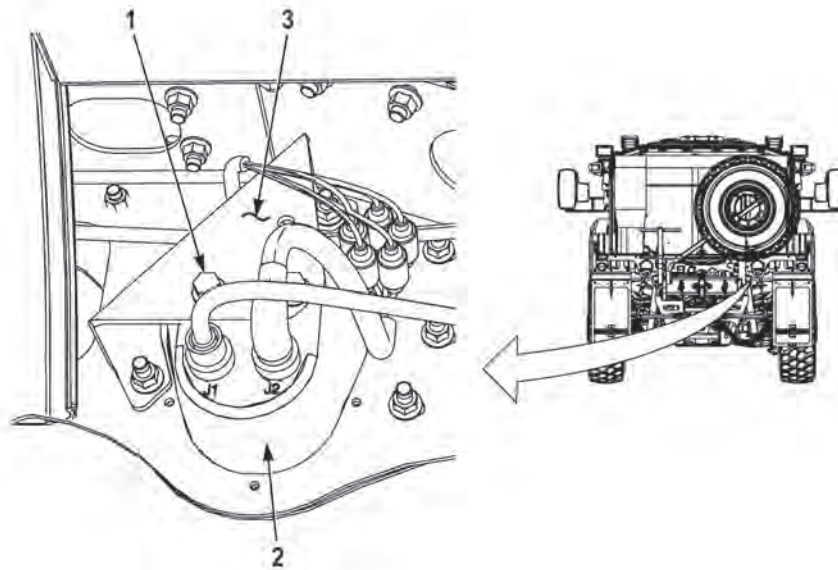
**REMOVAL****NOTE**

- Driver side and passenger side Check-6 rear composite lights are removed the same way.
- Passenger side shown.
- Tag and mark connectors prior to removal to ensure proper installation.

1. Remove two screws (1) and Check-6 rear composite light (2) from bracket (3).

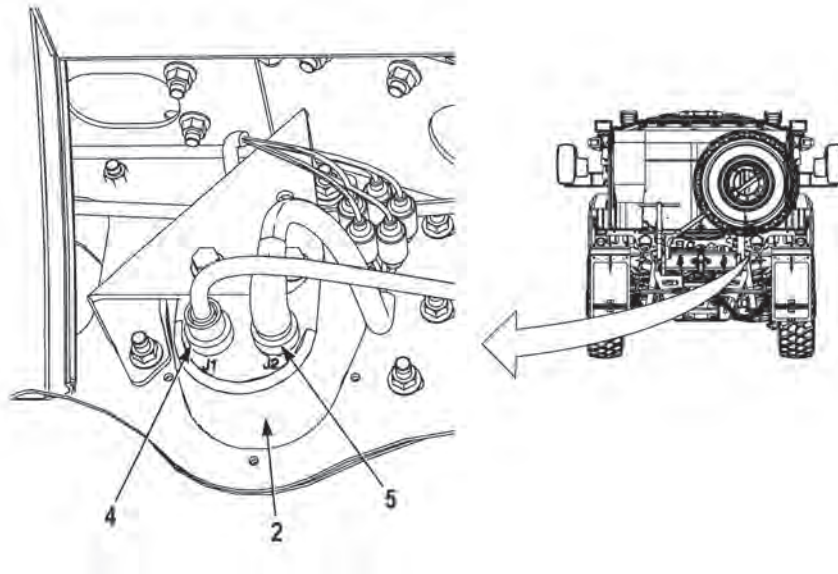

### NOTE

- Driver side and passenger side Check-6 rear composite lights are removed the same way.
- Passenger side shown.

2. Disconnect connector (4) from Check-6 rear composite light (2).
3. Disconnect connector (5) from Check-6 rear composite light (2).

### END OF TASK

### INSTALLATION

1. Connect connector (4) to Check-6 rear composite light (2).
2. Connect connector (5) to Check-6 rear composite light (2).

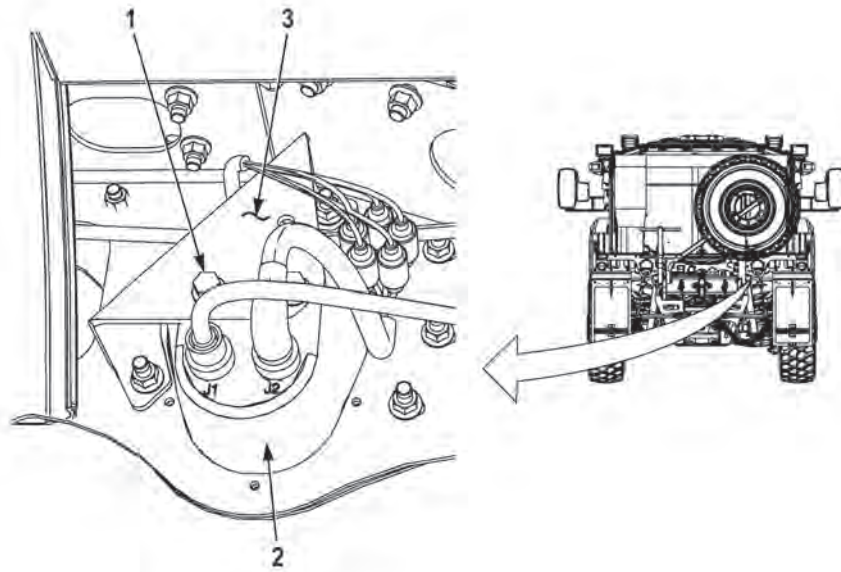

3. Install Check-6 rear composite light (2) on bracket (3) with two screws (1).
4. Perform all Follow-On Maintenance tasks.

**END OF TASK**

**END OF WORK PACKAGE**





---

**CIRCUIT BREAKER REPLACEMENT, AUXILIARY (M1240/M1240A1)**

---

**Preconditions**

Park vehicle  
Engine OFF  
Wheels chocked  
Batteries disconnected (M1240/M1240A1)  
(WP 0186)

**Tools and Special Tools**

Tool Kit, General Mechanic's: Automotive

**Materials/Parts**

Locknut (2) (Item 1)  
Locknut (2) (Item 6)

**Materials/Parts (Continued)**

Lockwasher (2) (Item 18)  
Lockwasher (2) (Item 22)  
Lockwasher (8) (Item 27)  
Lockwasher (Item 31)

**Follow-On Maintenance**

Connect batteries (M1240/M1240A1) (WP 0186)  
Remove and stow wheel chocks

---

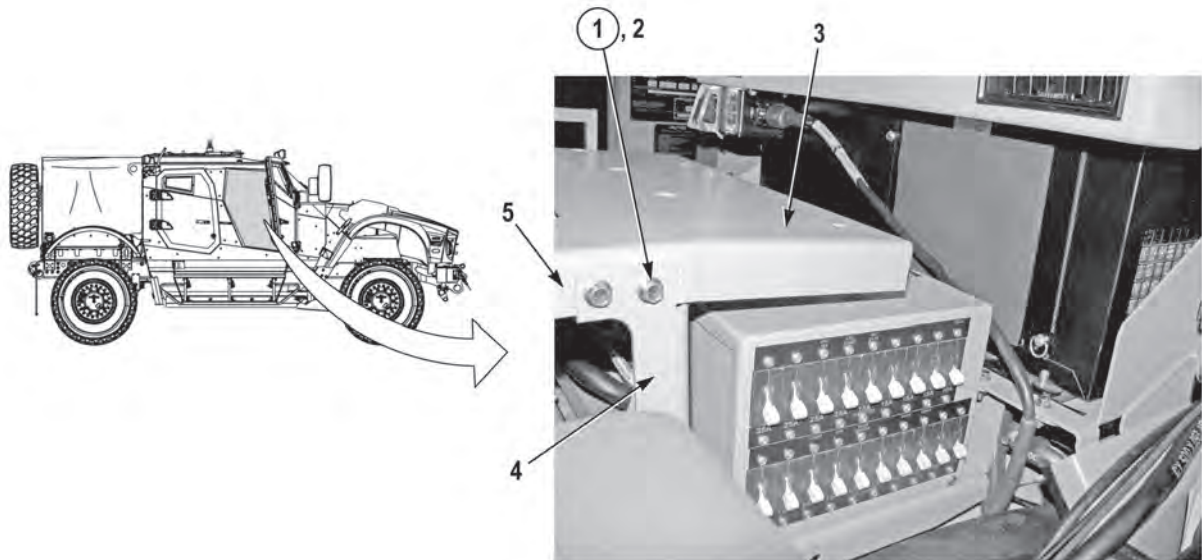
**REMOVAL**

1. Remove two locknuts (1), and screws (2) from front radio mount (3), bracket (4), and rear radio mount (5). Discard locknuts (1).

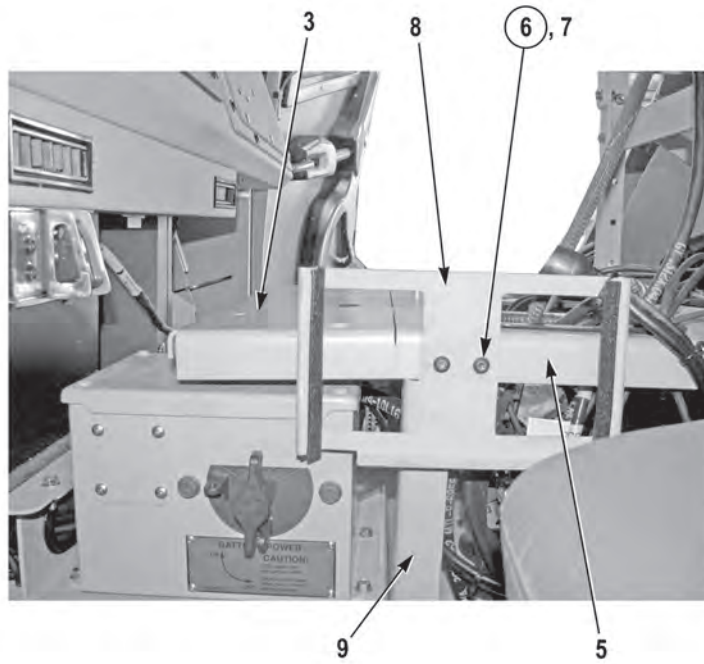

2. Remove two locknuts (6), screws (7), bracket (8), and front radio mount (3) from rear radio mount (5) and bracket (9). Discard locknuts (6).

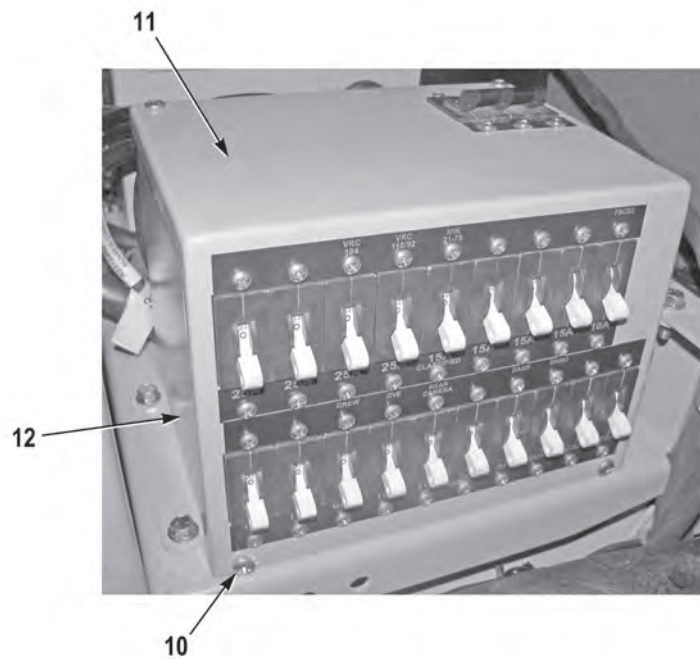

3. Remove four screws (10) and circuit breaker cover (11) from breather case (12).

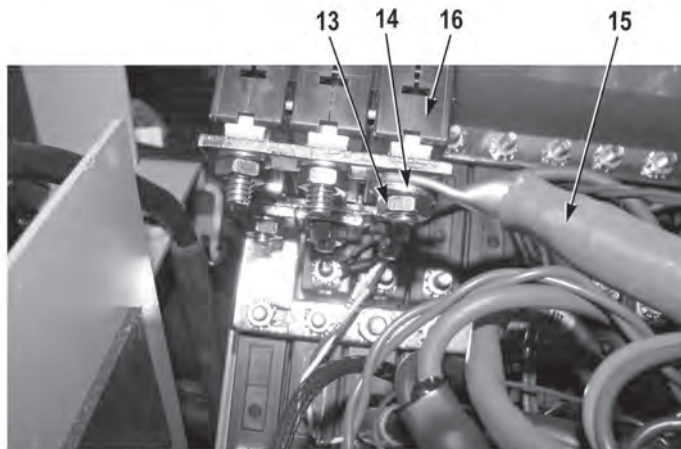

4. Remove nut (13), washer (14), and wire (15) from main circuit breaker (16).

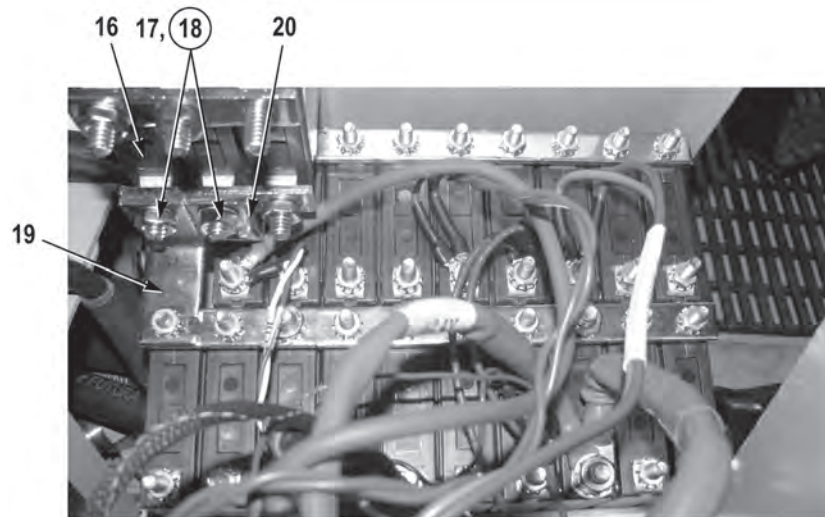

#### NOTE

If removing circuit breaker(s) on top row, main circuit breaker must first be removed.

5. Remove two nuts (17) and lockwashers (18) from tie bar (19), tie bar (20), and main circuit breaker (16). Discard lockwashers (18).

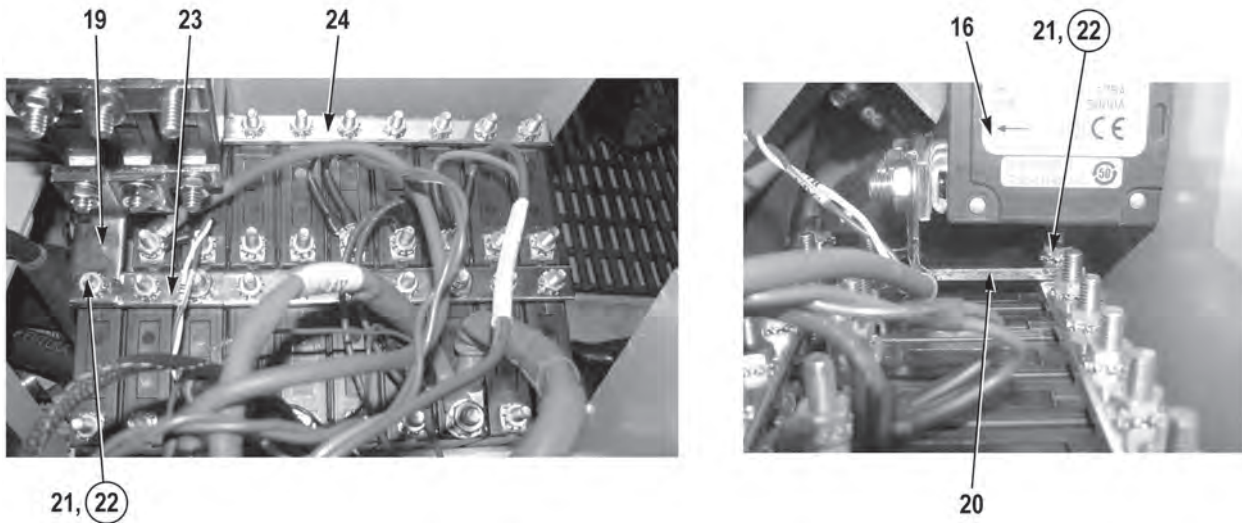

6. Remove two nuts (21), lockwashers (22), tie bar (19), and tie bar (20) from main circuit breaker (16), bus bar (23) and bus bar (24). Discard lockwashers (22).

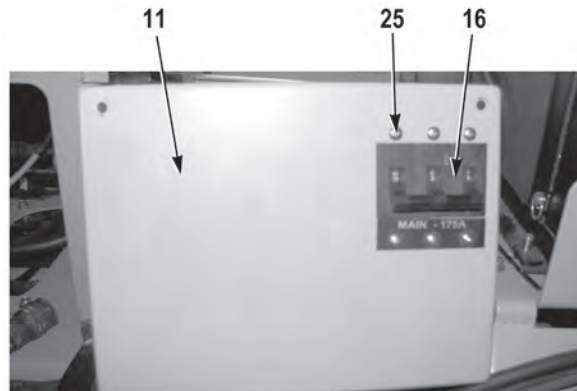

7. Remove six screws (25) and main circuit breaker (16) from circuit breaker cover (11).

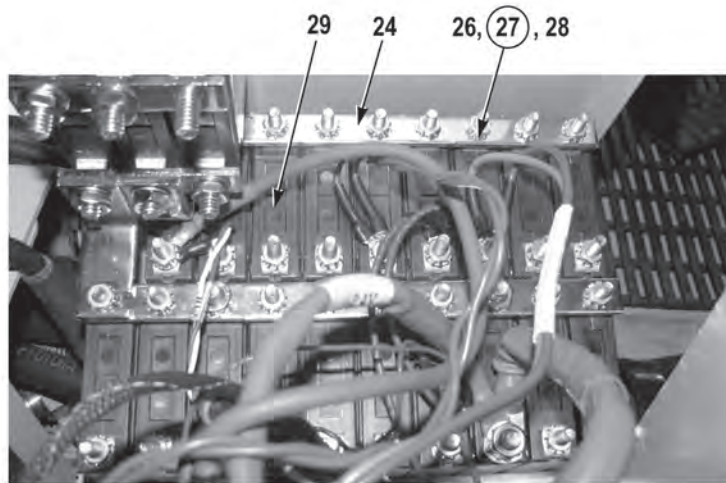

8. Remove eight nuts (26), lockwashers (27), bus bar (24), and nine washers (28) from nine circuit breakers (29). Discard lockwashers (27).

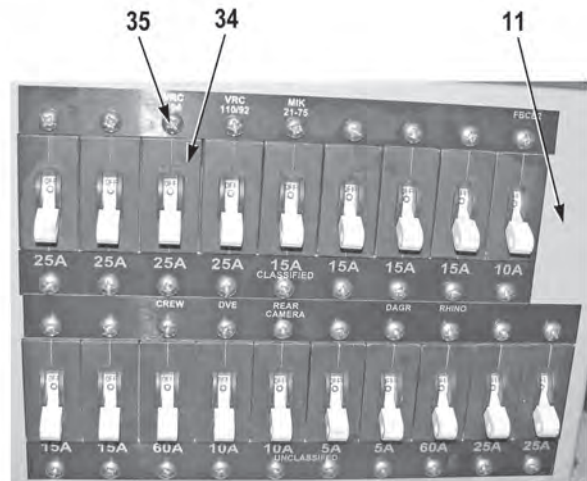
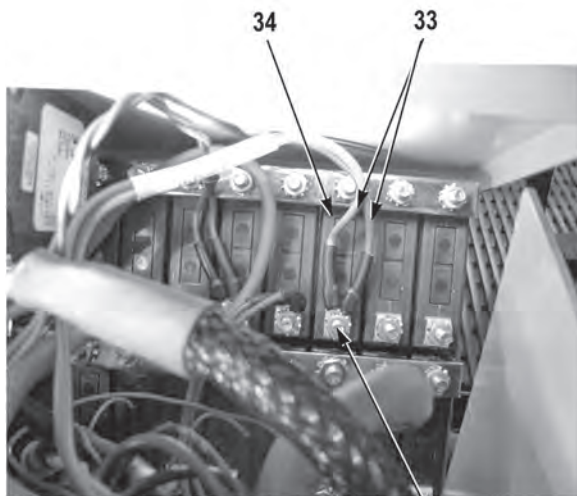

30, (31), 32

**NOTE**

All circuit breakers are removed the same way. Number of wires required to remove circuit breakers may vary, depending on equipment connected to circuit breakers.

9. Remove nut (30), lockwasher (31), washer (32), and two wires (33) from circuit breaker (34). Discard lockwasher (31).
10. Remove two screws (35) and circuit breaker (34) from circuit breaker cover (11).

**END OF TASK**



**INSTALLATION**

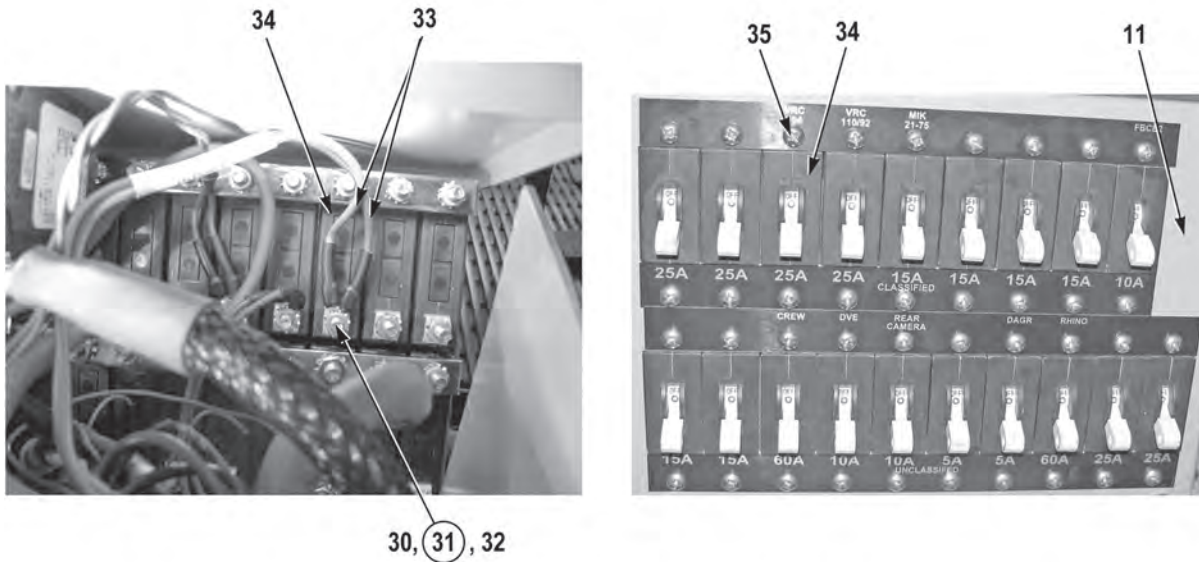

1. Install circuit breaker (34) on circuit breaker cover (11) with two screws (35).
2. Install two wires (33) on circuit breaker (34) with washers (32), new lockwashers (31), and nut (30).

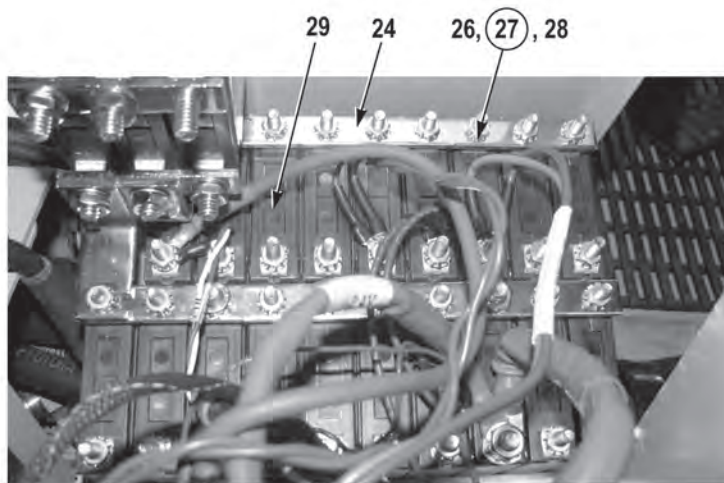

**NOTE**

All circuit breakers are removed the same way. Number of wires required to install circuit breakers may vary, depending on equipment connected to circuit breakers.

3. Position nine washers (28) on circuit breakers (29).
4. Install bus bar (24) on nine circuit breakers (29) with eight new lockwashers (27) and nuts (26).

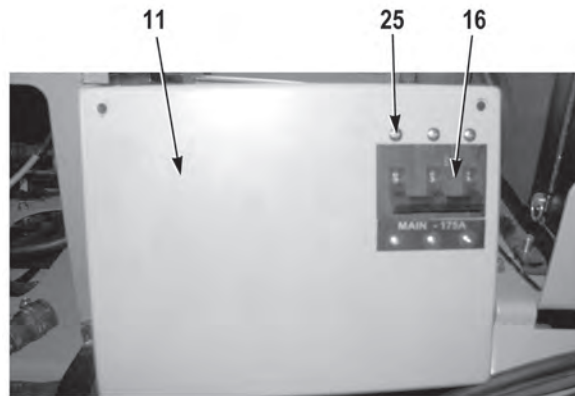

5. Install main circuit breaker (16) on circuit breaker cover (11) with six screws (25).

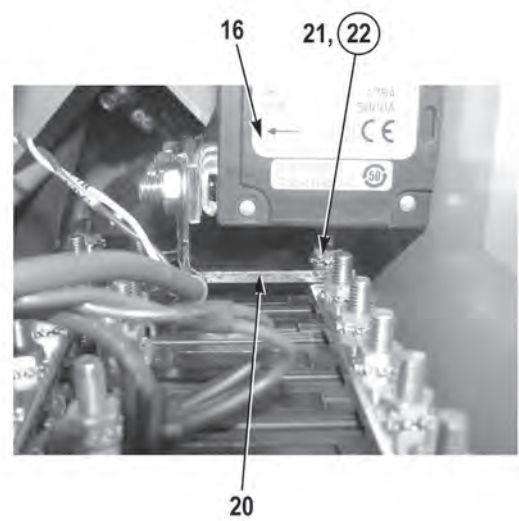
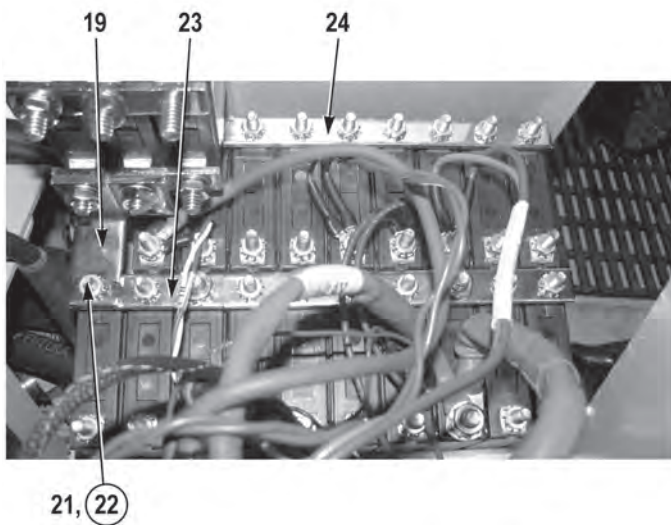

6. Install tie bar (20) and tie bar (19) on bus bar (24), bus bar (23), and main circuit breaker (16) with two new lockwashers (22) and nuts (21).



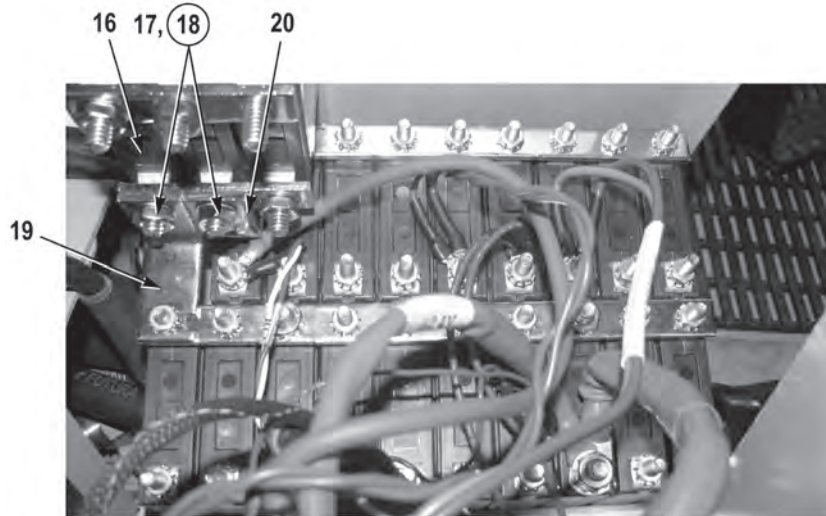

7. Secure tie bar (19) and tie bar (20) on main circuit breaker (16) with two new lockwashers (18) and nuts (17).

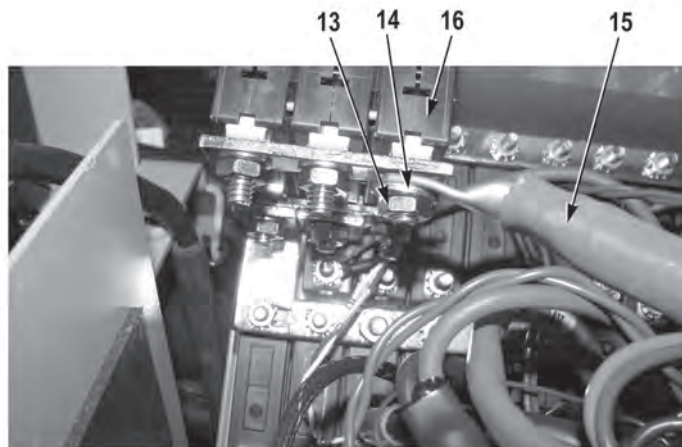

8. Install wire (15) on main circuit breaker (16) with washer (14) and nut (13).

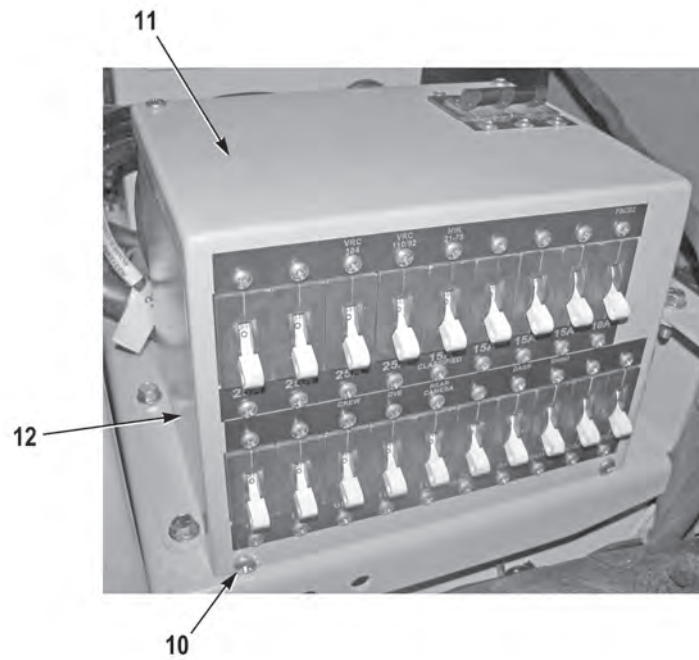

9. Install circuit breaker cover (11) on breather case (12) with four screws (10).

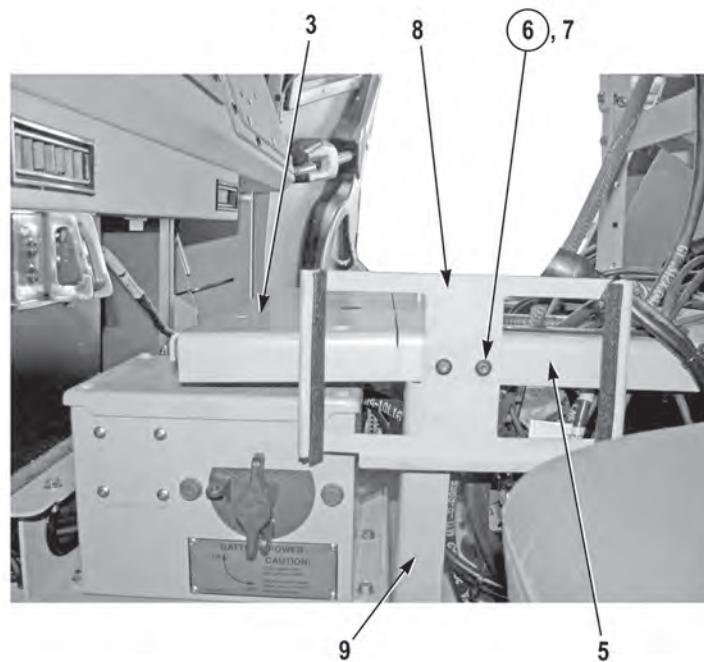

10. Install front radio mount (3) and bracket (8) on rear radio mount (5) and bracket (9) with two screws (7) and new locknuts (6).

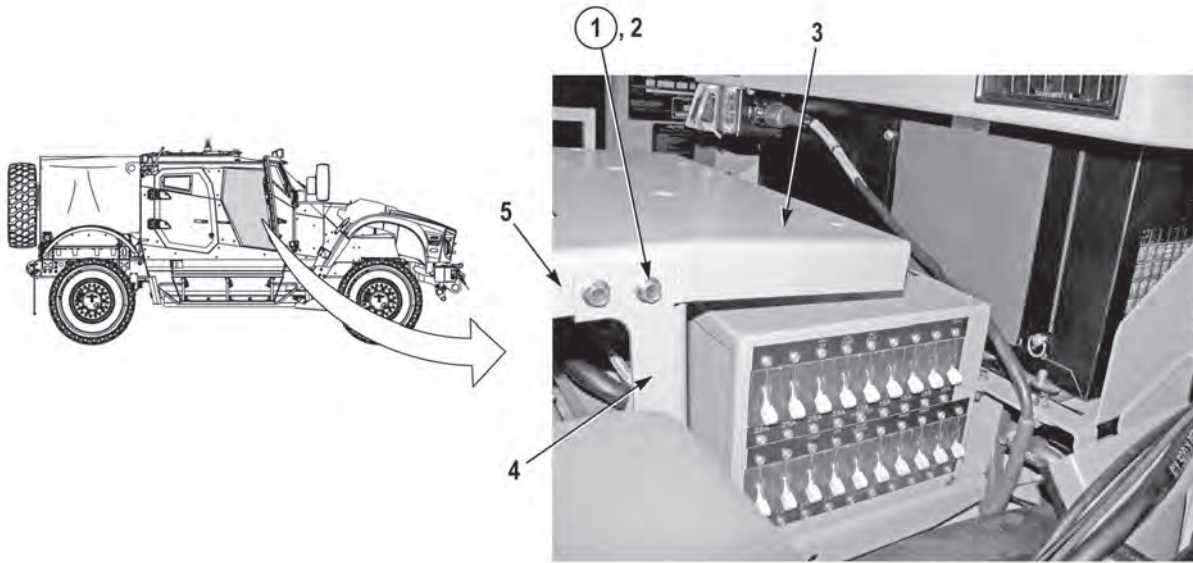

11. Install front radio mount (3) on bracket (4) and rear radio mount (5) with two screws (2) and new locknuts (1).
12. Perform all Follow-On Maintenance tasks.

**END OF TASK**

**END OF WORK PACKAGE**

---

## CIRCUIT BREAKER REPLACEMENT, DASH

---

**Preconditions**

Park vehicle  
 Engine OFF  
 Wheels chocked  
 Batteries disconnected (M1240/M1240A1)  
 (WP 0186)  
 Batteries disconnected (M1245) (WP 0187)

**Materials/Parts**

Lubricant, Connector, Nyogel, 760G

**Follow-On Maintenance**

Connect batteries (M1240/M1240A1) (WP 0186)  
 Connect batteries (M1245) (WP 0187)  
 Remove and stow wheel chocks

**Tools and Special Tools**

Tool Kit, General Mechanic's: Automotive

---

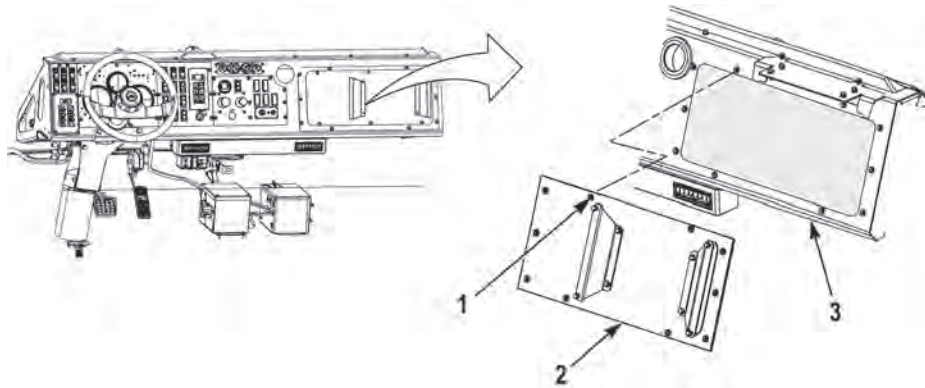
**REMOVAL****NOTE**

- Manual and automatic reset circuit breakers are used. Both are removed the same way. Manual circuit breaker shown.
  - Note the amp and type of circuit breaker prior to removal to ensure proper installation.
  - Before performing replacement, depress and hold button on manual circuit breaker for 15 seconds, or wait 15 seconds for automatic circuit breaker to attempt reset.
1. Remove ten screws (1) and dash circuit breaker cover (2) from dash (3).

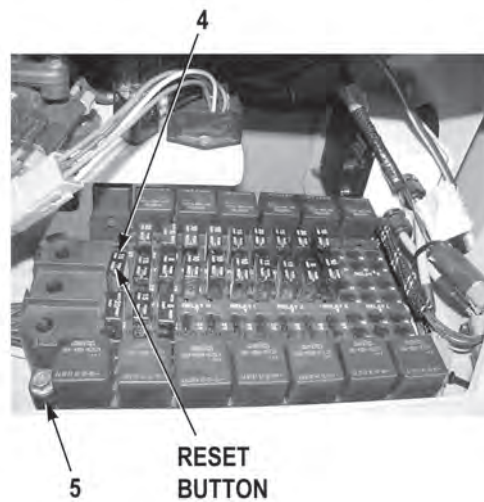

2. Remove circuit breaker (4) from circuit breaker panel (5).
3. Position circuit breaker (4) on clean work surface.

#### END OF TASK

#### INSTALLATION

#### WARNING

Connector lubricant is harmful to skin. Prolonged or repeated contact with skin or contact with eyes may cause irritation. If eyes are contacted, rinse thoroughly and contact physician if irritation persists. If skin is contacted, wash thoroughly with soap and water. Failure to comply may result in injury or death to personnel.

#### NOTE

Manual and automatic reset circuit breakers are used. Both are installed the same way. Manual circuit breaker shown.

1. Apply connector lubricant, Nyogel 760G, to circuit breaker (4).
2. Install circuit breaker (4) on circuit breaker panel (5).

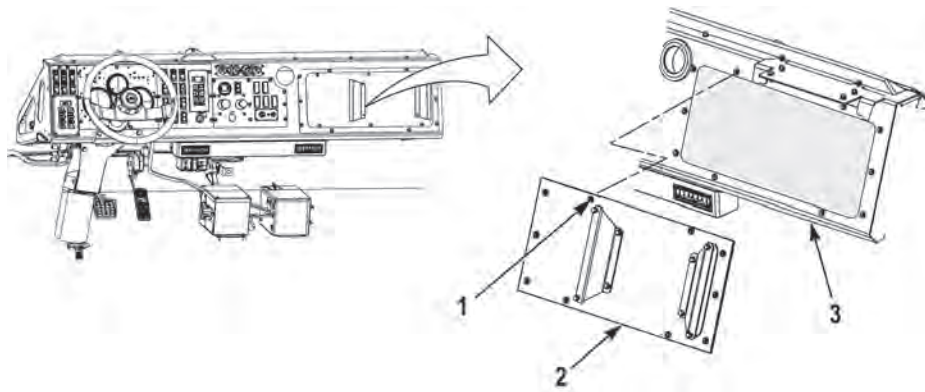
**NOTE**

Perform Step (3) only when installing manual circuit breakers.

3. Depress and hold reset button for 15 seconds.
4. Install dash circuit breaker cover (2) on dash (3) with ten screws (1).

**END OF TASK**

**END OF WORK PACKAGE**





---

**CLEARANCE LIGHTS REPLACEMENT**

---

**Preconditions**

Park vehicle  
 Engine OFF  
 Wheels chocked  
 Batteries disconnected (M1240/M1240A1)  
 (WP 0186)  
 Batteries disconnected (M1245) (WP 0187)

**Tools and Special Tools**

Tool Kit, General Mechanic's: Automotive

**Materials/Parts**

Locknut (4) (Item 1)  
 Locknut (2) (Item 1)  
 Lockwasher (2) (Item 2)  
 Ties, Cable

**Follow-On Maintenance**

Connect batteries (M1240/M1240A1) (WP 0186)  
 Connect batteries (M1245) (WP 0187)  
 Remove and stow wheel chocks

---

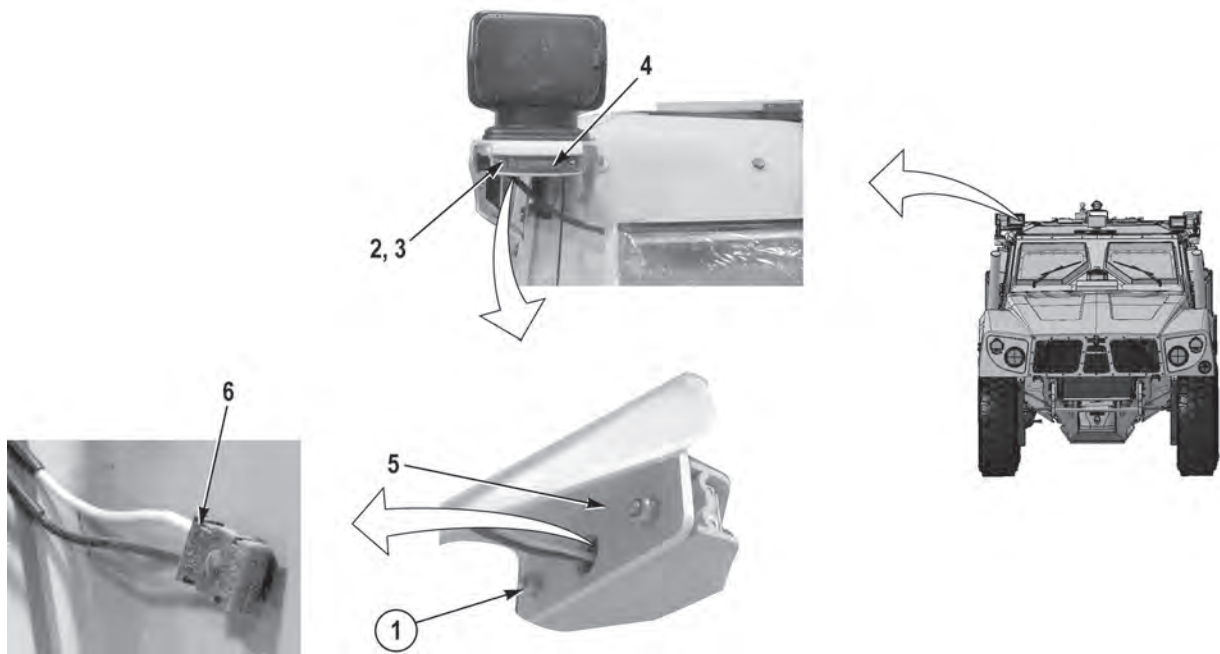
**SPOTLIGHT CLEARANCE LIGHTS REMOVAL****NOTE**

Driver side and passenger side clearance lights are removed the same way. Passenger side shown.

1. Remove two locknuts (1), screws (2), washers (3), and pull spotlight clearance light (4) away from bracket (5). Discard locknuts (1).
2. Disconnect connector (6) from spotlight clearance light (4) and remove spotlight clearance light (4) from vehicle.
3. Repeat Steps (1) and (2) for driver side.

**END OF TASK**

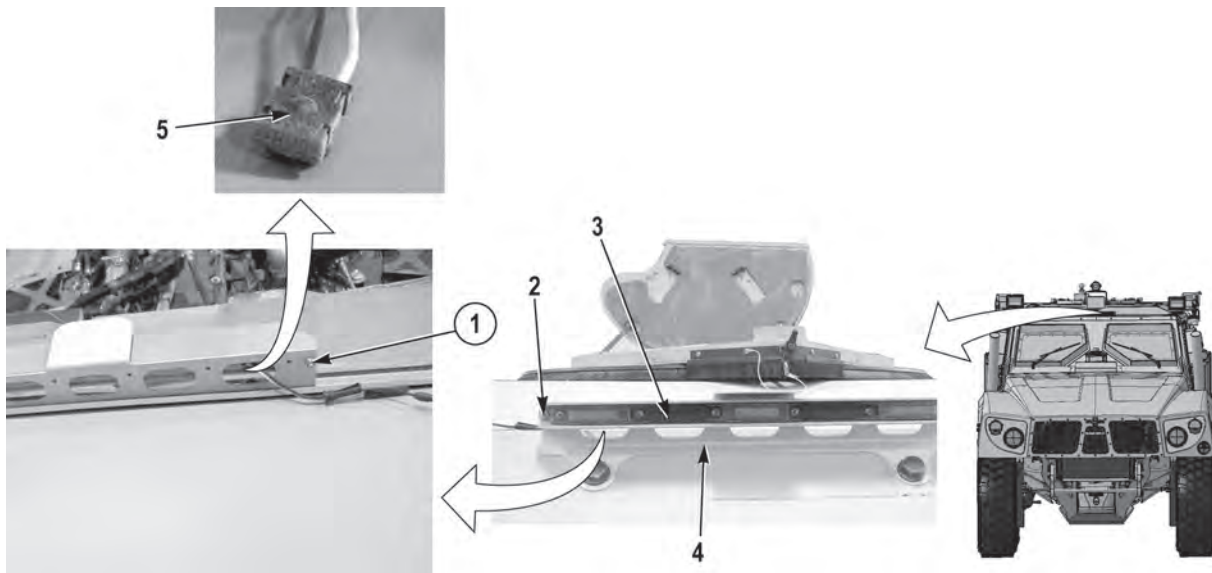
**CAPSULE CLEARANCE LIGHT ASSEMBLY REMOVAL****NOTE**

Remove cable ties as required.

1. Remove two locknuts (1), screws (2), and pull capsule clearance light assembly (3) away from bracket (4). Discard locknuts (1).
2. Disconnect three connectors (5) from capsule clearance light assembly (3) and remove capsule clearance light assembly (3) from vehicle.

**END OF TASK**

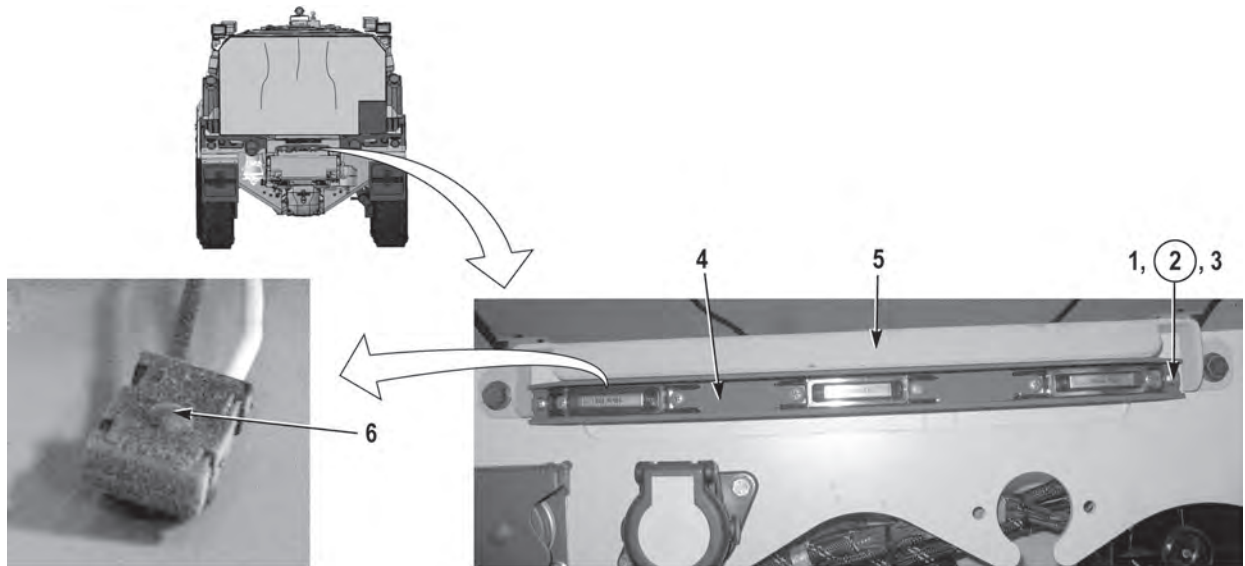
**REAR CLEARANCE LIGHT ASSEMBLY REMOVAL**

1. Remove two nuts (1), lockwashers (2), screws (3), and pull rear clearance light assembly (4) from bracket (5). Discard lockwashers (2).
2. Disconnect three connectors (6) from spotlight clearance light assembly (4) and remove spotlight clearance light assembly (4) from vehicle.

**END OF TASK**

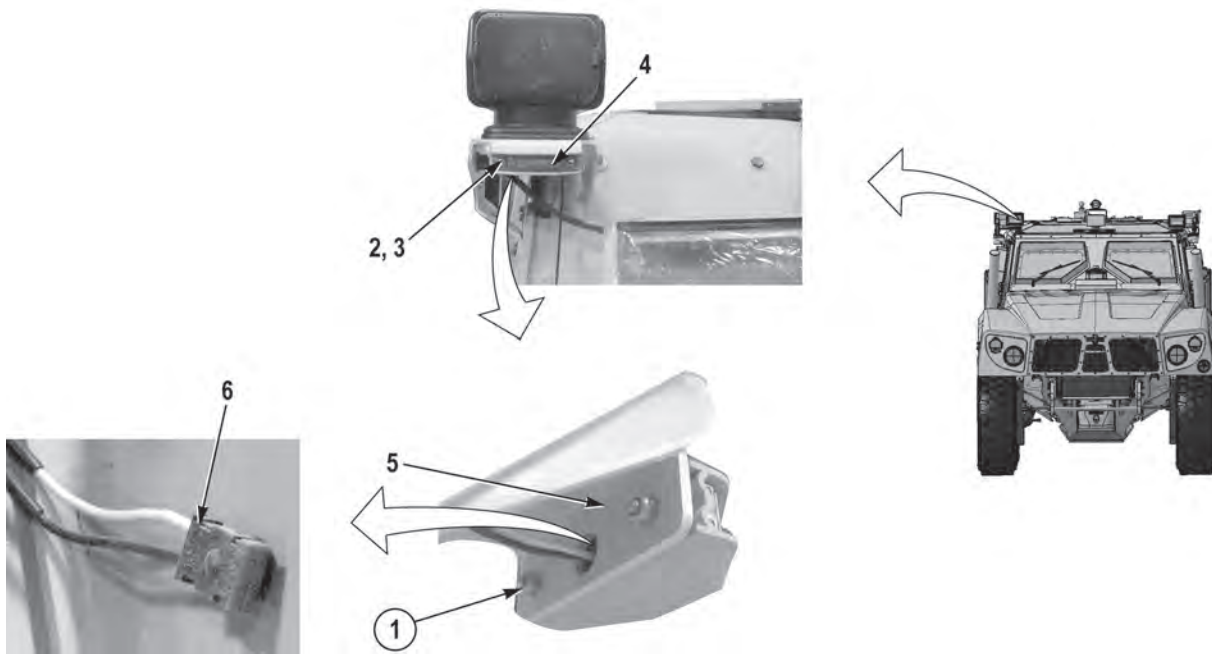
**SPOTLIGHT CLEARANCE LIGHTS INSTALLATION****NOTE**

Driver side and passenger side clearance lights are installed the same way. Passenger side shown.

1. Connect connector (6) to spotlight clearance light (4).
2. Install spotlight clearance light (4) on bracket (5) with two washers (3), screws (2), and new locknuts (1).
3. Repeat Steps (1) and (2) for driver side.
4. Perform all Follow-On Maintenance tasks.

**END OF TASK**

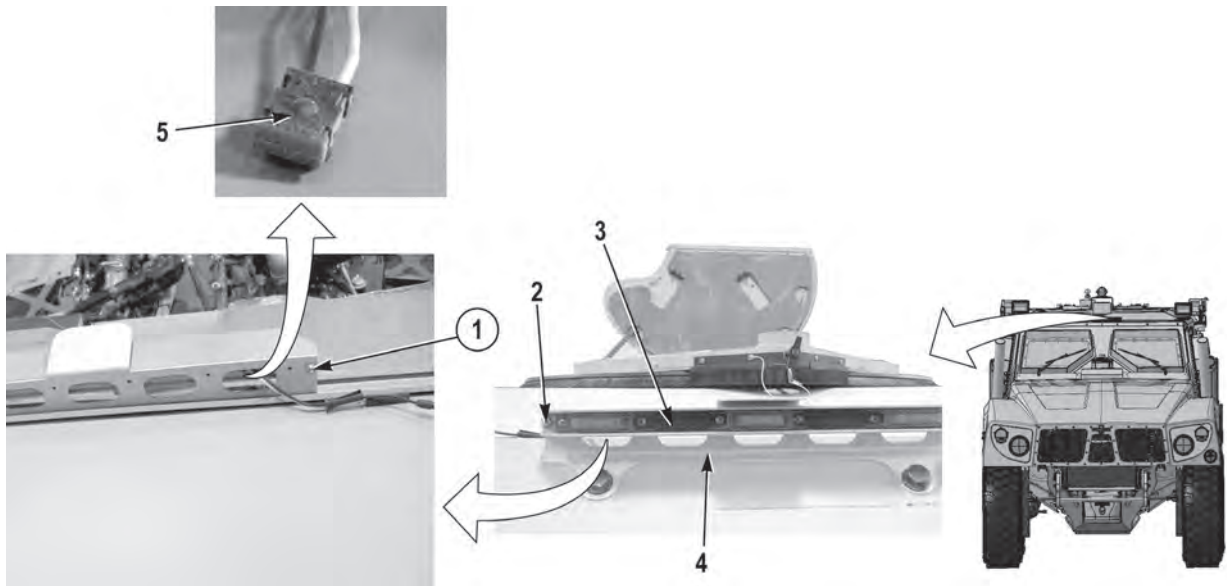
**CAPSULE CLEARANCE LIGHT ASSEMBLY INSTALLATION**

1. Connect three connectors (5) on capsule clearance light assembly (3).

**NOTE**

Install cable ties as required.

2. Install capsule clearance light assembly (3) on bracket (4) with two screws (2) and new locknuts (1).
3. Perform all Follow-On Maintenance tasks.

**END OF TASK**

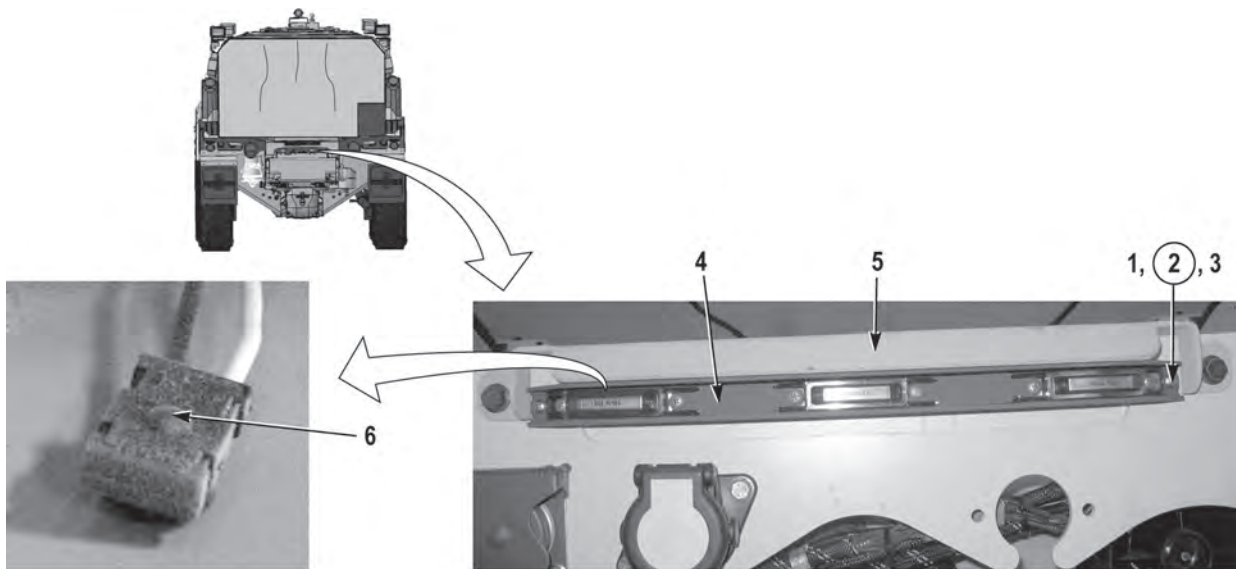
**REAR CLEARANCE LIGHT ASSEMBLY INSTALLATION**

1. Connect three connectors (6) on rear clearance light assembly (4).
2. Install rear clearance light assembly (4) on bracket (5) with two screws (3), new lockwashers (2), and nuts (1).
3. Perform all Follow-On Maintenance tasks.

**END OF TASK****END OF WORK PACKAGE**

---

**DEICER CIRCUIT BREAKER REPLACEMENT**

---

**Preconditions**

Park vehicle  
 Engine OFF  
 Wheels chocked  
 Transmission dash panel removed (WP 0150)

**Tools and Special Tools**

Tool Kit, General Mechanic's: Automotive

**Materials/Parts**

Locknut (2) (Item 3)  
 Locknut (2) (Item 6)  
 Tags, Identification

**Follow-On Maintenance**

Install transmission dash panel (WP 0150)  
 Remove and stow wheel chocks

---

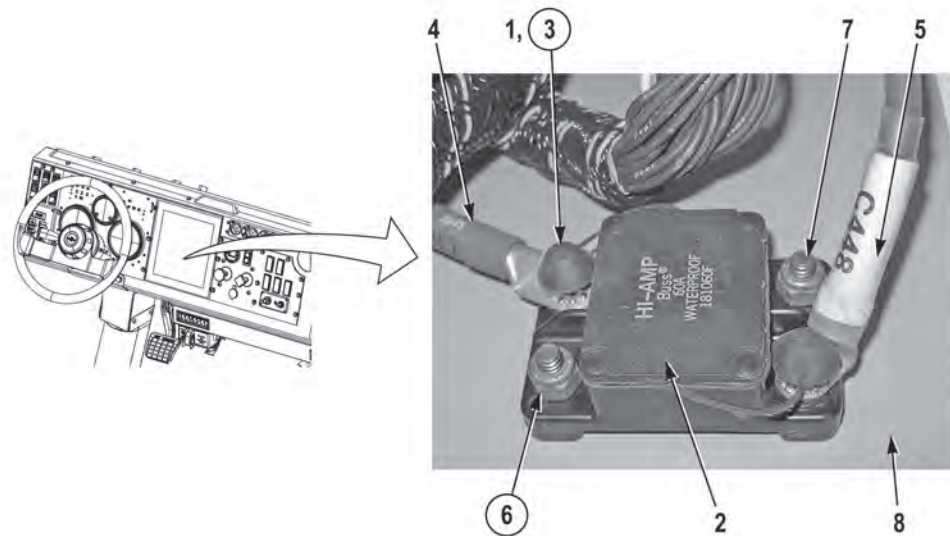
**REMOVAL****NOTE**

Tag and mark wires prior to removal to ensure proper installation.

1. Remove two rubber plugs (1) from deicer circuit breaker (2).
2. Remove two locknuts (3) and wires (4 and 5) from deicer circuit breaker (2). Discard locknuts (3).
3. Remove two locknuts (6), screws (7) and deicer circuit breaker (2) from dash assembly (8). Discard locknuts (6).

**END OF TASK**

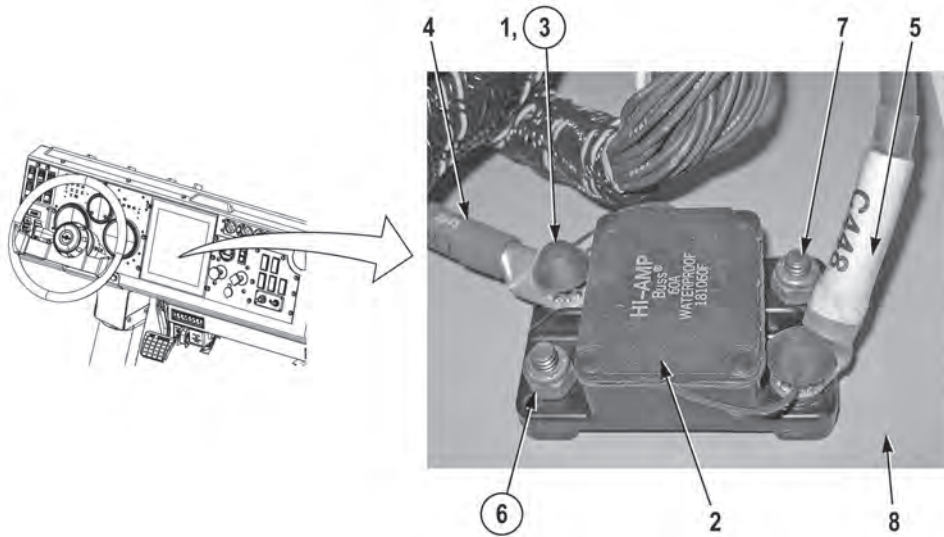

**INSTALLATION****NOTE**

Install wire connectors as noted prior to removal.

1. Install deicer circuit breaker (2) on dash assembly (8) with two screws (7) and new locknuts (6).
2. Install two wires (4 and 5) on deicer circuit breaker (2) with two new locknuts (3).
3. Install two rubber plugs (1) on deicer circuit breaker (2).
4. Perform all Follow-On Maintenance tasks.

**END OF TASK**

**END OF WORK PACKAGE**

---

**DIMMER REPLACEMENT**

---

**Preconditions**

Park vehicle  
 Engine OFF  
 Wheels chocked  
 Batteries disconnected (M1240/M1240A1)  
 (WP 0186)  
 Batteries disconnected (M1245) (WP 0187)

**Tools and Special Tools**

Tool Kit, General Mechanic's: Automotive

**Materials/Parts**

Locknuts (2) (Item 6)  
 Tags, Identification

**Follow-On Maintenance**

Connect batteries (M1240/M1240A1) (WP 0186)  
 Connect batteries (M1245) (WP 0187)  
 Remove and stow wheel chocks

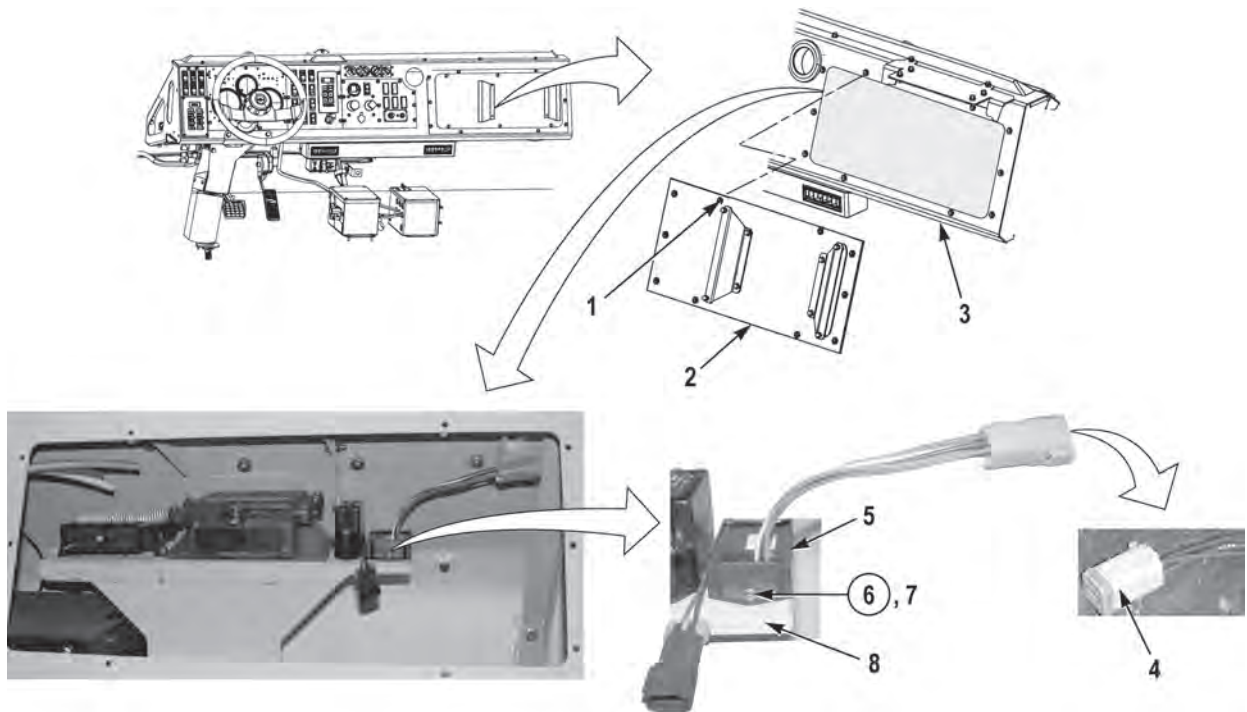
**REMOVAL**

1. Remove ten screws (1) and dash circuit breaker cover (2) from dash (3).

**NOTE**

Tag and mark connectors prior to removal to ensure proper installation.

2. Disconnect connector (4) from dimmer (5).
3. Remove two locknuts (6), screws (7), and dimmer (5) from dash panel compartment tray (8). Discard locknuts (6).

**END OF TASK**

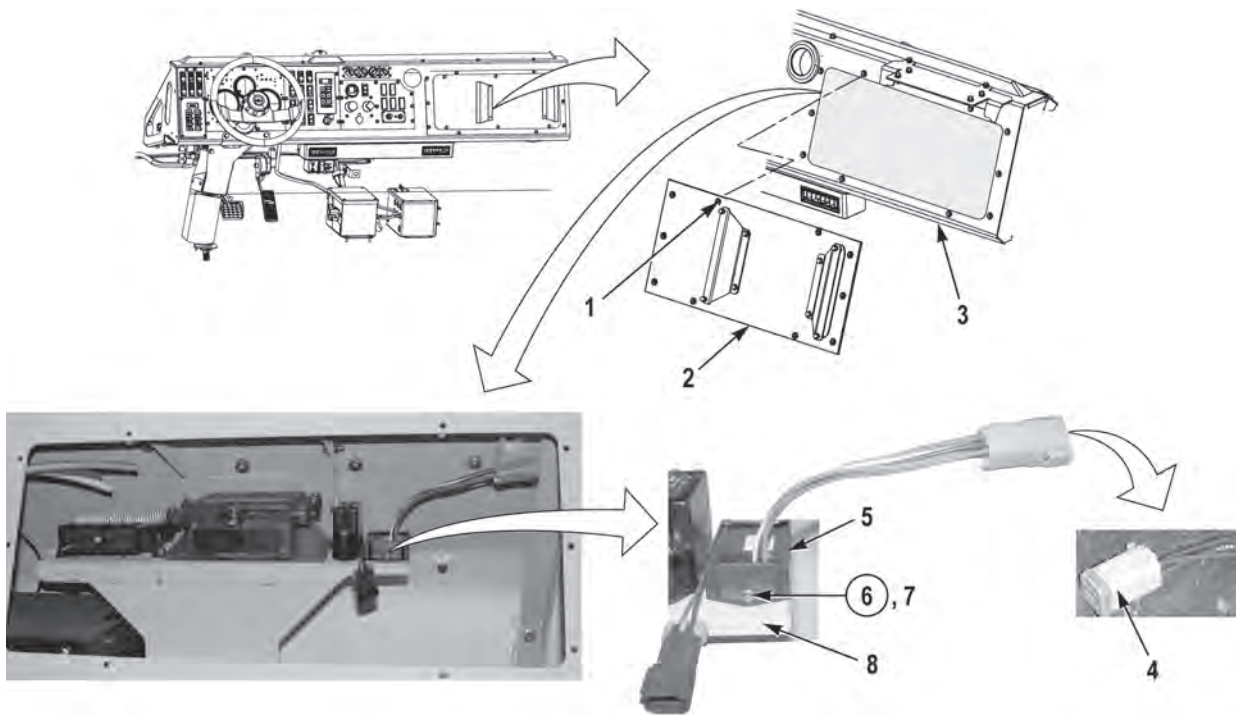
**INSTALLATION**

1. Install dimmer (5) on dash panel compartment tray (8) with two screws (7) and new locknuts (6).
2. Connect connector (4) to dimmer (5).
3. Install dash circuit breaker cover (2) on dash (3) with ten screws (1).
4. Perform all Follow-On Maintenance tasks.

**END OF TASK****END OF WORK PACKAGE**

---

**ELECTROMAGNETIC INTERFERENCE (EMI) FILTER REPLACEMENT**

---

**Preconditions**

Park vehicle  
 Engine OFF  
 Wheels chocked  
 Hood opened and secured  
 Batteries disconnected (M1240/M1240A1)  
 (WP 0186)  
 Batteries disconnected (M1245) (WP 0187)

**Tools and Special Tools**

Tool Kit, General Mechanic's: Automotive

**Materials/Parts**

Lockwasher (2) (Item 10)  
 Compound, Sealing, Loctite 242  
 Tags, Identification  
 Ties, Cable

**Follow-On Maintenance**

Connect batteries (M1240/M1240A1) (WP 0186)  
 Connect batteries (M1245) (WP 0187)  
 Close and secure hood  
 Remove and stow wheel chocks

---

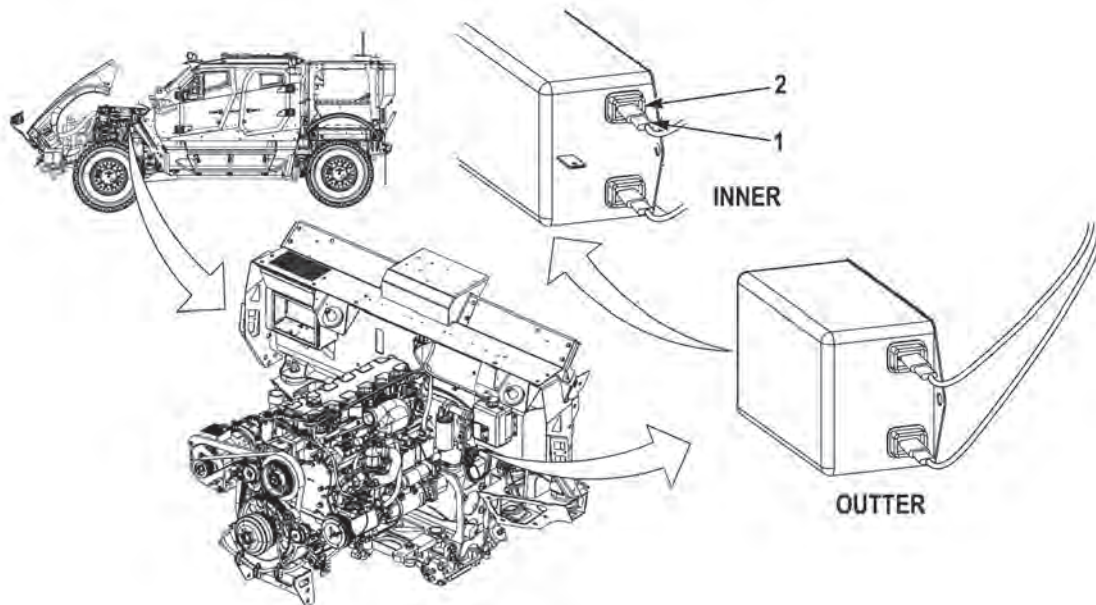
**REMOVAL****NOTE**

- Tag and mark wires prior to removal to ensure proper installation.
- Remove cable ties as required.

1. Disconnect wire (1) from EMI filter positive line terminal (2).

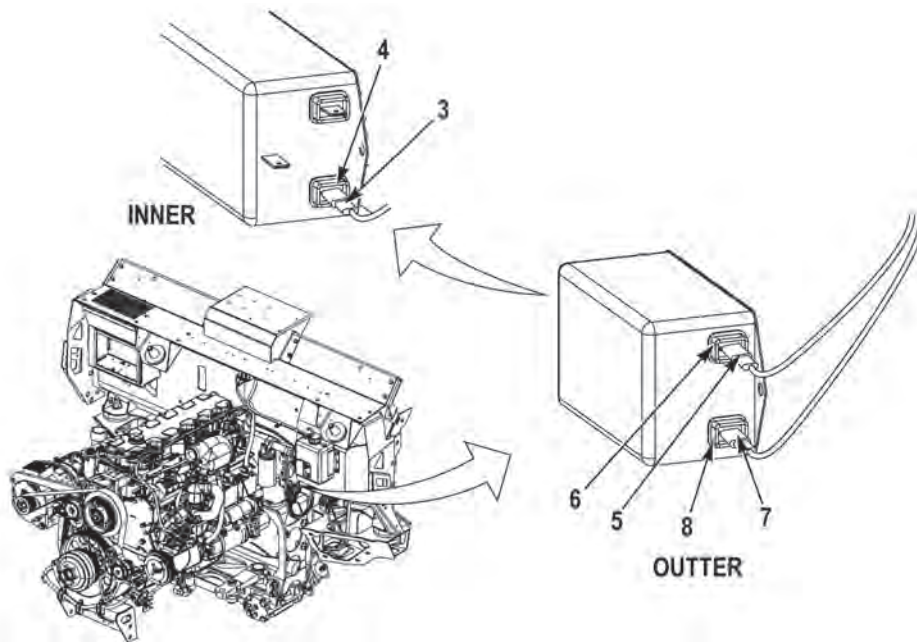

2. Disconnect wire (3) from EMI filter negative line terminal (4).
3. Disconnect wire (5) from EMI filter positive load terminal (6).
4. Disconnect wire (7) from EMI filter negative load terminal (8).

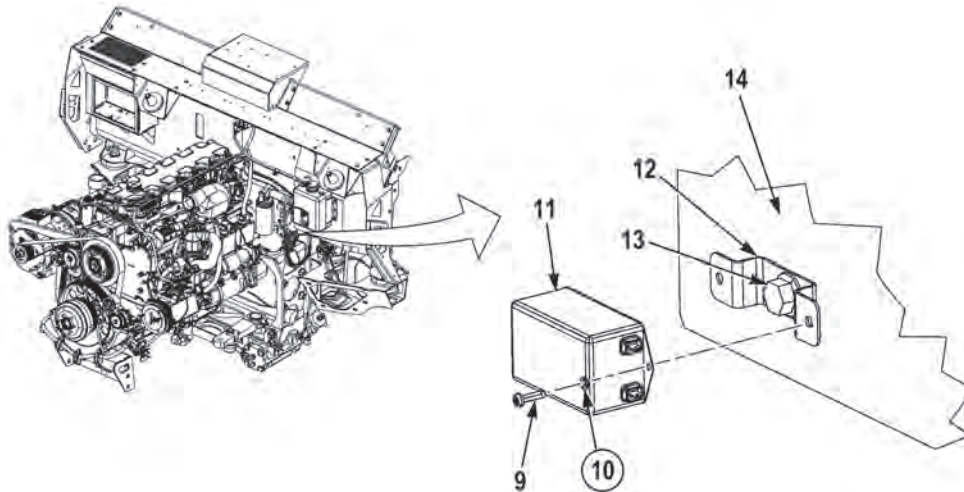

5. Remove two screws (9), lockwashers (10), and EMI filter (11) from EMI filter mounting bracket (12). Discard lockwashers (10).

### NOTE

Perform Step (6) if EMI filter mounting bracket needs to be removed.

6. Remove screw (13) and EMI filter mounting bracket (12) from firewall panel (14).

**END OF TASK**



**INSTALLATION****WARNING**

Adhesives, solvents, and sealing compounds can burn easily, can give off harmful vapors, and are harmful to skin and clothing. To avoid injury or death, keep away from open fire and use in well-ventilated area. If adhesive, solvent, or sealing compound gets on skin or clothing, wash immediately with soap and water. Failure to comply may result in injury or death to personnel.

**NOTE**

Perform Steps (1) and (2) if EMI filter mounting bracket was removed.

1. Apply sealing compound, Loctite 242, to threads of screw (13).
2. Install EMI filter mounting bracket (12) on firewall panel (14) with screw (13).
3. Install EMI filter (11) on EMI filter mounting bracket (12) with two new lockwashers (10) and screws (9).

**NOTE**

Install cable ties as required.

4. Connect wire (7) to EMI filter negative load terminal (8).
5. Connect wire (5) to EMI filter positive load terminal (6).
6. Connect wire (3) to EMI filter negative line terminal (4).

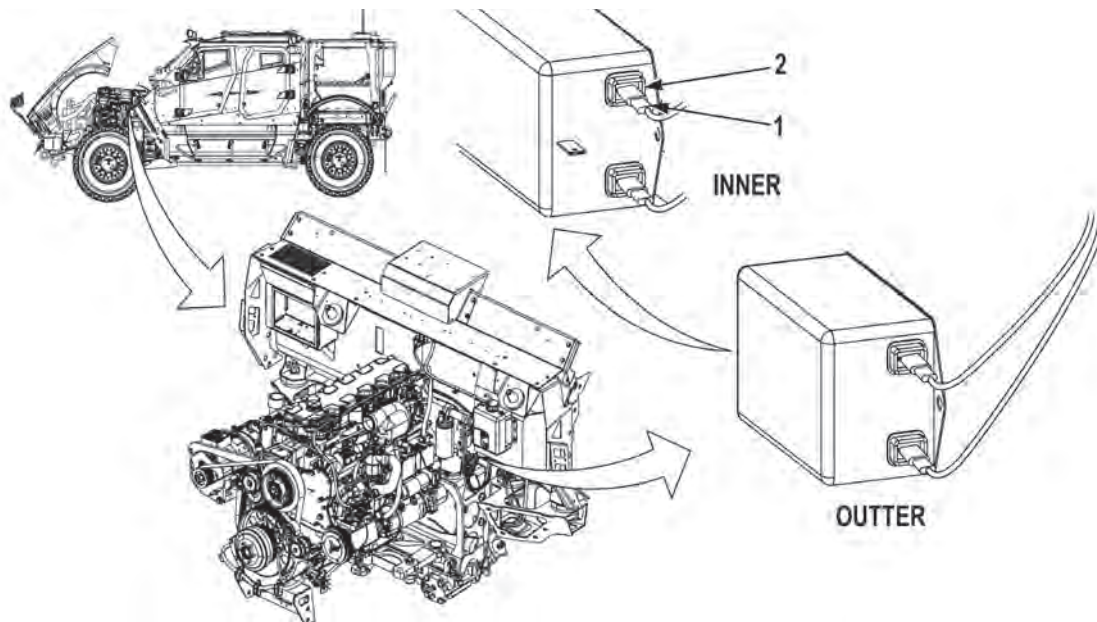

7. Connect wire (1) to EMI filter positive line terminal (2).
8. Perform all Follow-On Maintenance tasks.

**END OF TASK**

**END OF WORK PACKAGE**





---

**FLASHER REPLACEMENT**

---

**Preconditions**

Park vehicle  
 Engine OFF  
 Wheels chocked  
 Batteries disconnected (M1240/M1240A1)  
 (WP 0186)  
 Batteries disconnected (M1245) (WP 0187)

**Tools and Special Tools**

Tool Kit, General Mechanic's: Automotive

**Materials/Parts**

Locknuts (2) (Item 6)  
 Tags, Identification

**Follow-On Maintenance**

Connect batteries (M1240/M1240A1) (WP 0186)  
 Connect batteries (M1245) (WP 0187)  
 Remove and stow wheel chocks

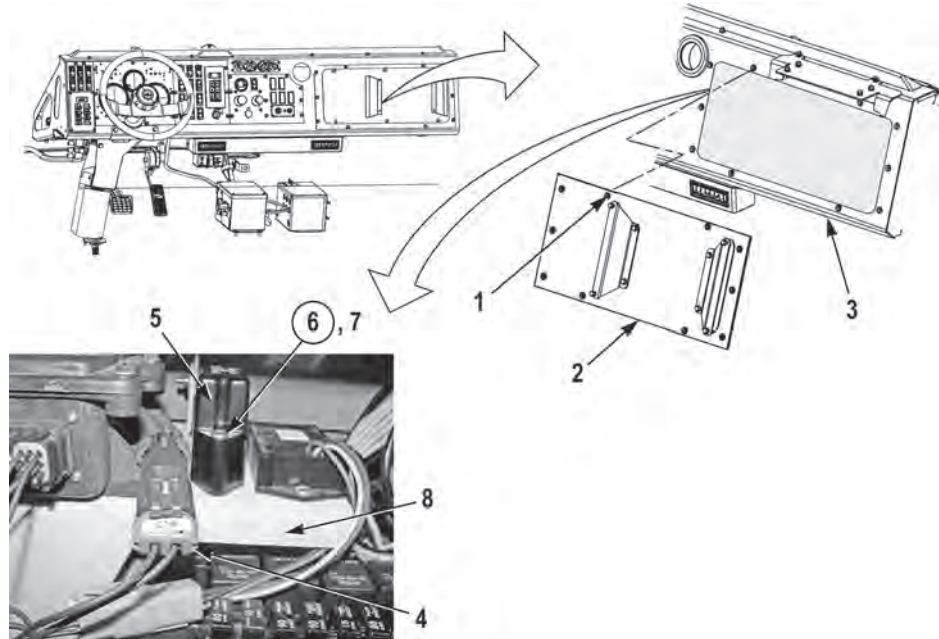
**REMOVAL**

1. Remove ten screws (1) and dash circuit breaker cover (2) from dash (3).

**NOTE**

Tag and mark connectors prior to removal to ensure proper installation.

2. Disconnect connector (4) from flasher (5).
3. Remove two locknuts (6), screws (7), and flasher (5) from dash panel compartment tray (8). Discard locknuts (6).

**END OF TASK**

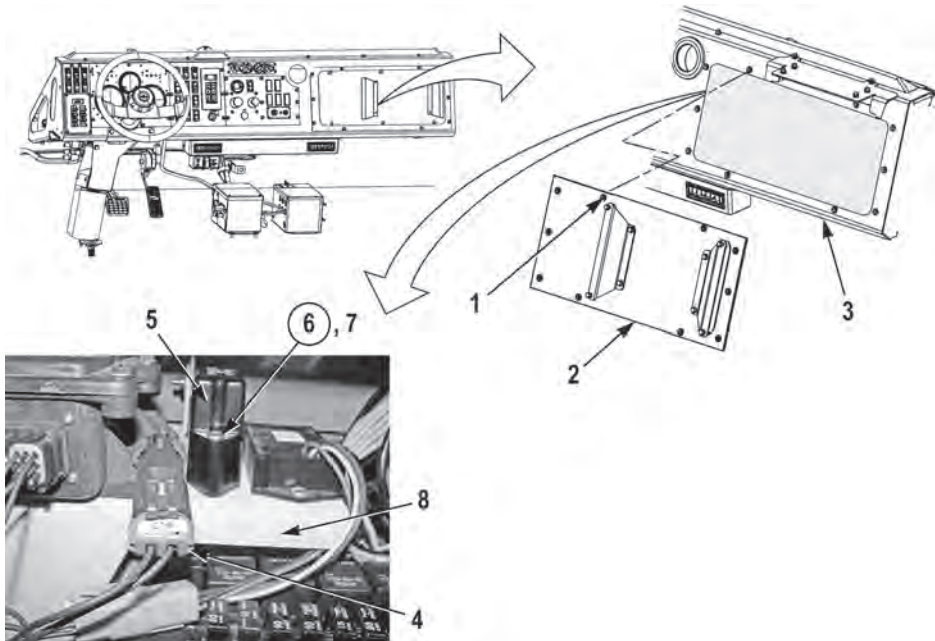
**INSTALLATION**

1. Install flasher (5) on dash panel compartment tray (8) with two screws (7) and new locknuts (6).
2. Connect connector (4) to flasher (5).
3. Install dash circuit breaker cover (2) on dash (3) with ten screws (1).
4. Perform all Follow-On Maintenance tasks.

**END OF TASK****END OF WORK PACKAGE**

---

**FRONT COMPOSITE LIGHT REPLACEMENT**

---

**Preconditions**

Park vehicle  
 Engine OFF  
 Wheels chocked  
 Hood opened and secured  
 Batteries disconnected (M1240/M1240A1)  
 (WP 0186)  
 Batteries disconnected (M1245) (WP 0187)

**Tools and Special Tools**

Tool Kit, General Mechanic's: Automotive

**Materials/Parts**

Locknut (5) (Item 1)  
 Compound, Corrosion Preventive, Ultra Tef-Gel  
 05SA2  
 Lubricant, Connector, Nyogel 760G  
 Tags, Identification  
 Ties, Cable

**Follow-On Maintenance**

Connect batteries (M1240/M1240A1) (WP 0186)  
 Connect batteries (M1245) (WP 0187)  
 Close hood and secure  
 Remove and stow wheel chocks

---

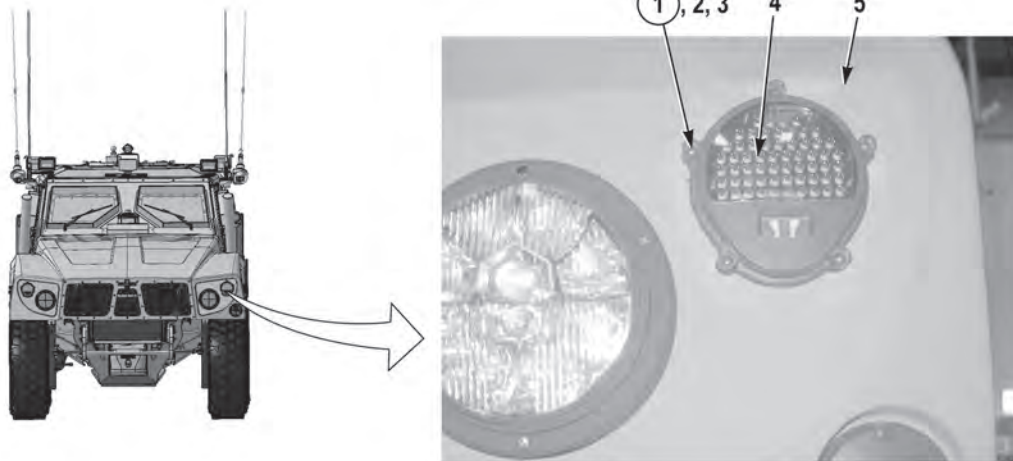
**REMOVAL****NOTE**

- Both front composite lights are removed the same way. Driver side shown.
  - Remove cable ties as required.
  - Tag and mark wires prior to removal to ensure proper installation.
1. Remove five locknuts (1), washers (2), screws (3), and front composite light (4) from hood (5). Discard locknuts (1).

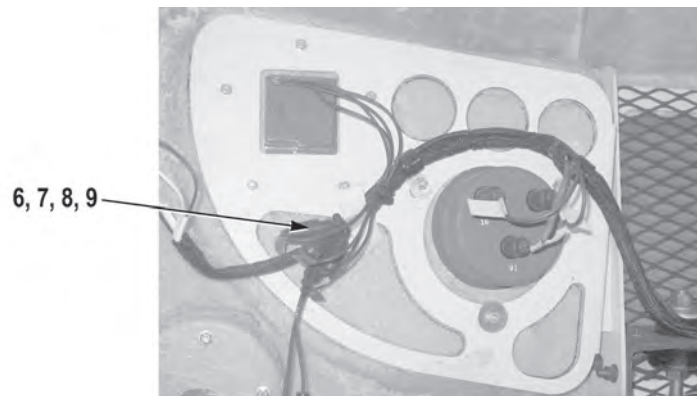

2. Disconnect four connectors (6, 7, 8, and 9).

### END OF TASK

### INSTALLATION

#### NOTE

- Install wires as noted prior to removal.
- Install cable ties as required.

1. Connect four connectors (9, 8, 7, and 6).

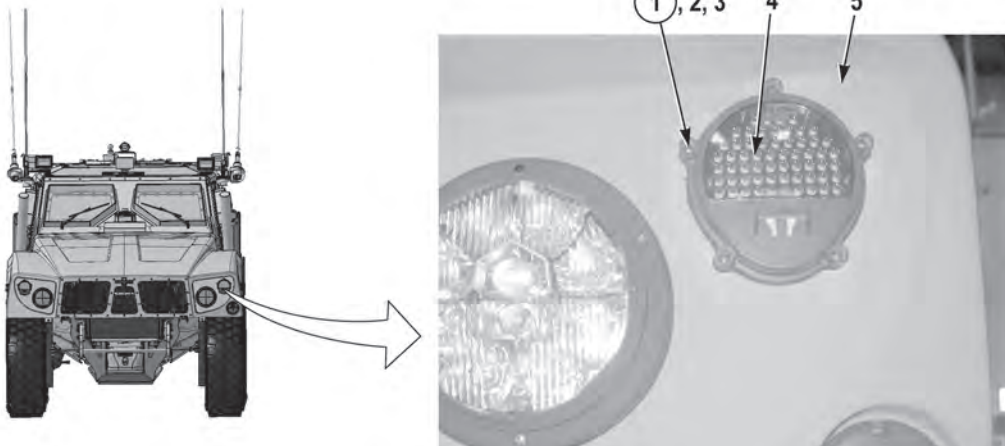

#### NOTE

Both front composite lights are installed the same way. Driver side shown.

2. Install front composite light (4) on hood (5) with five screws (3), washers (2), and new locknuts (1).
3. Perform all Follow-On Maintenance tasks.

### END OF TASK

### END OF WORK PACKAGE

---

**HEADLIGHT REPLACEMENT**

---

**Preconditions**

Park vehicle  
 Engine OFF  
 Wheels chocked  
 Hood opened and secured  
 Batteries disconnected (M1240/M1240A1)  
 (WP 0186)  
 Batteries disconnected (M1245) (WP 0187)

**Materials/Parts**

Locknut (3) (Item 8)  
 Tags, Identification

**Follow-On Maintenance**

Connect batteries (M1240/M1240A1) (WP 0186)  
 Connect batteries (M1245) (WP 0187)  
 Close hood and secure  
 Remove and stow wheel chocks

**Tools and Special Tools**

Tool Kit, General Mechanic's: Automotive

---

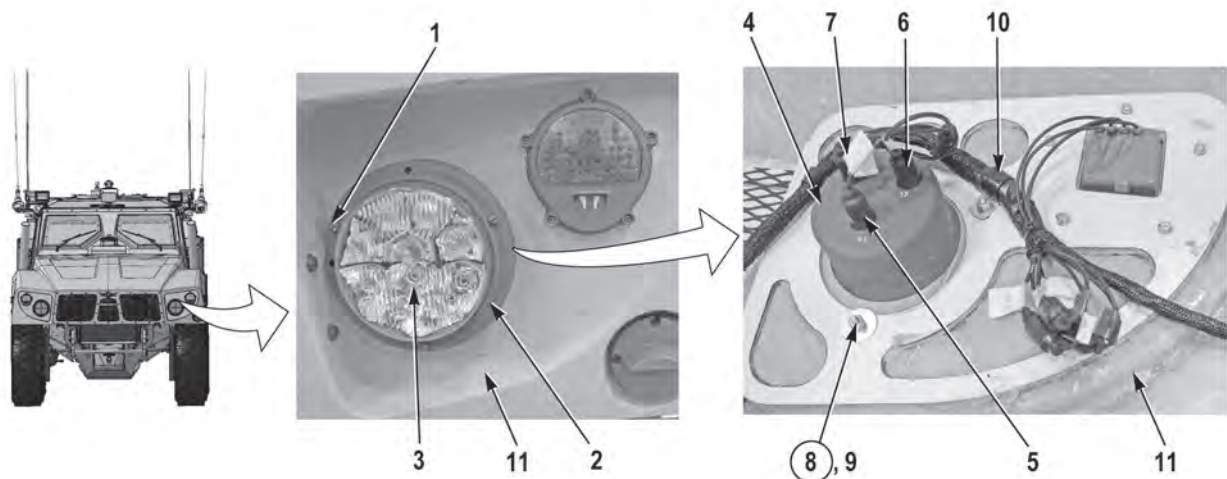
**REMOVAL****NOTE**

Both headlight lamps are removed the same way. Driver side shown.

1. Loosen three screws (1) and remove headlight retaining ring (2) and headlight (3) from headlight bracket (4).

**NOTE**

Tag and mark wires prior to removal to ensure proper installation.

2. Disconnect three connectors (5, 6, and 7) from headlight bracket (4).

**NOTE**

Note position of cushion clips and washer prior to removal to ensure proper installation.

3. Remove three locknuts (8), washers (9), two cushion clips (10), and headlight bracket (4) from hood (11). Discard locknuts (8).

**END OF TASK**

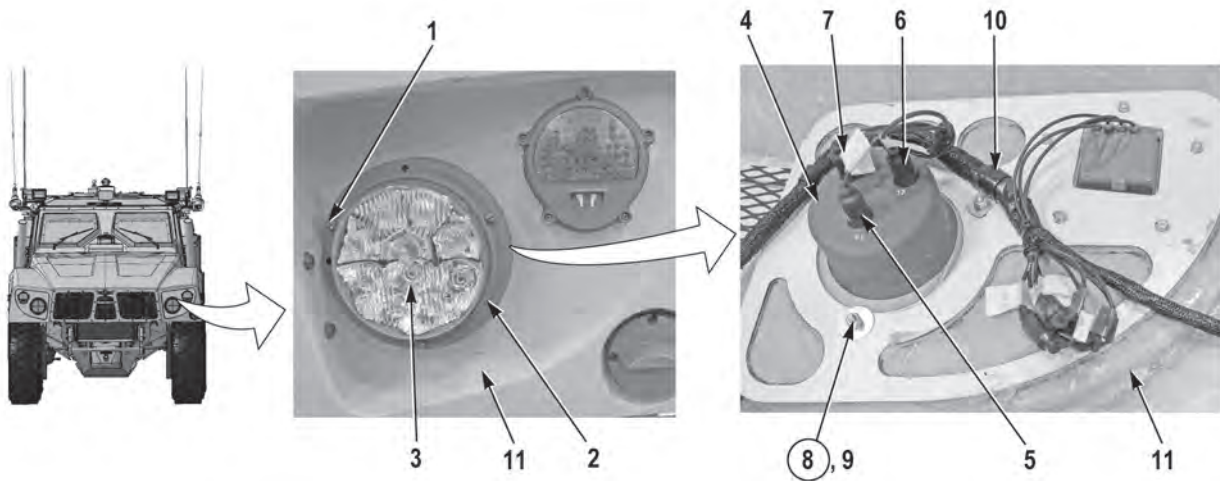
**INSTALLATION****NOTE**

- Both headlight lamps are installed the same way. Driver side shown.
- Install cushion clips and washer as noted prior to removal.

1. Install headlight bracket (4) and two cushion clips (10) on hood (11) with three washers (9) and new locknuts (8).
2. Connect three connectors (7, 6, and 5) to headlight bracket (4).
3. Install headlight (3) and headlight retaining ring (2) on headlight bracket (4) with three screws (1).
4. Perform all Follow-On Maintenance tasks.

**END OF TASK****END OF WORK PACKAGE**



---

**IGNITION RELAY REPLACEMENT**

---

**Preconditions**

Park vehicle  
 Engine OFF  
 Wheels chocked  
 Transmission dash panel removed (WP 0150)

**Tools and Special Tools**

Tool Kit, General Mechanic's: Automotive

**Materials/Parts**

Locknut (2) (Item 2)  
 Tags, Identification

**Follow-On Maintenance**

Install transmission dash panel (WP 0150)  
 Remove and stow wheel chocks

---

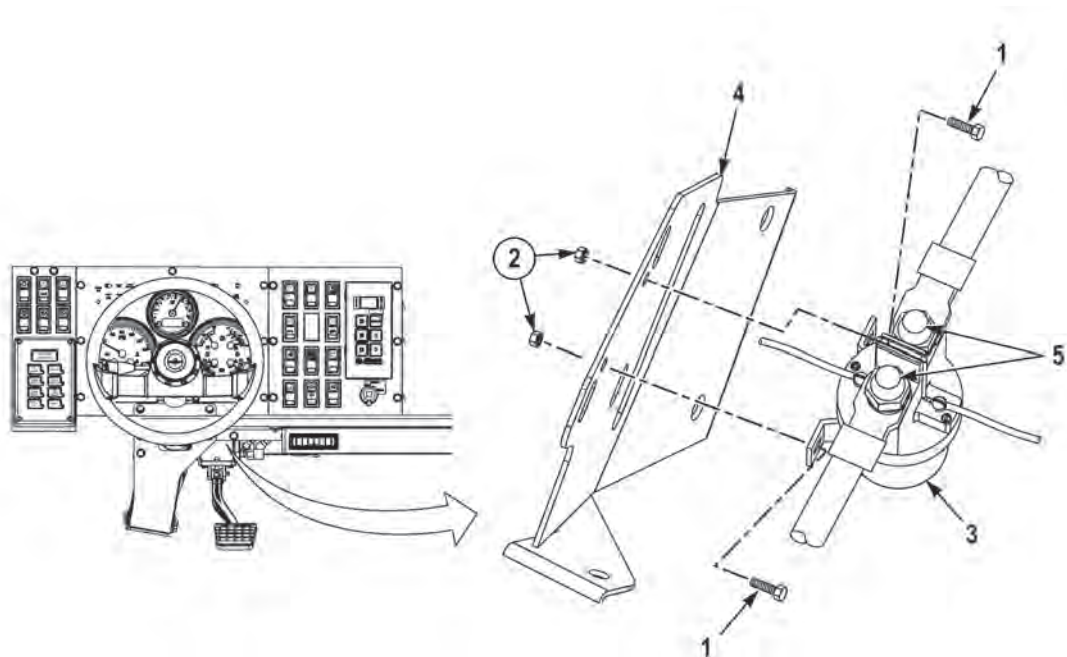
**REMOVAL****CAUTION**

**Support ignition relay during removal to prevent relay from hanging by wires.  
 Failure to comply may result in damage to equipment.**

1. Remove two screws (1), locknuts (2), and ignition relay (3) from steering column (4). Discard locknuts (2).

**NOTE**

Tag and mark wires prior to removal to ensure proper installation.

2. Remove two rubber caps (5) from ignition relay (3).



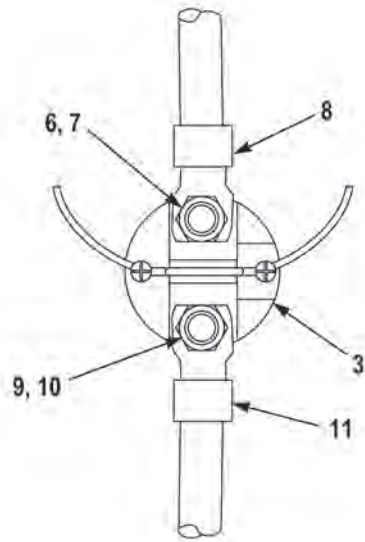

3. Remove nut (6), washer (7), and wire (8) from ignition relay (3).
4. Remove nut (9), washer (10), and wire (11) from ignition relay (3).

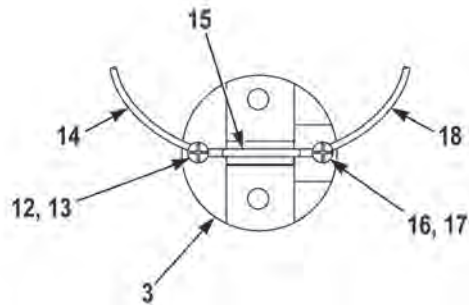

5. Remove screw (12), washer (13), and wire (14) from diode (15) and ignition relay (3).

### NOTE

Note position of diode prior to removal to ensure proper installation.

6. Remove screw (16), washer (17), wire (18), and diode (15) from ignition relay (3).

**END OF TASK**

**INSTALLATION****CAUTION**

Support ignition relay during installation to prevent relay from hanging by wires.  
Failure to comply may result in damage to equipment.

**NOTE**

Install diode as noted prior to removal.

1. Install diode (15) and wire (18) on ignition relay (3) with washer (17), and screw (16).
2. Install diode (15) and wire (14), on ignition relay (3) with washer (13), and screw (12).

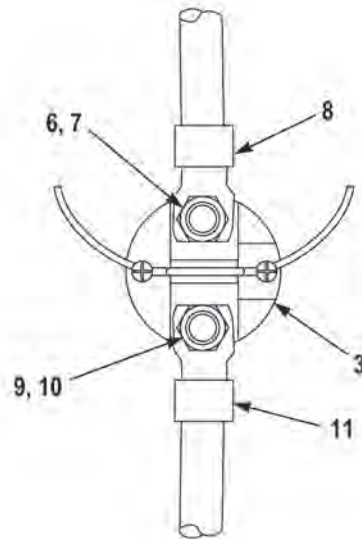

3. Install wire (11) on ignition relay (3) with washer (10) and nut (9).
4. Install wire (8) on ignition relay (3) with washer (7) and nut (6).

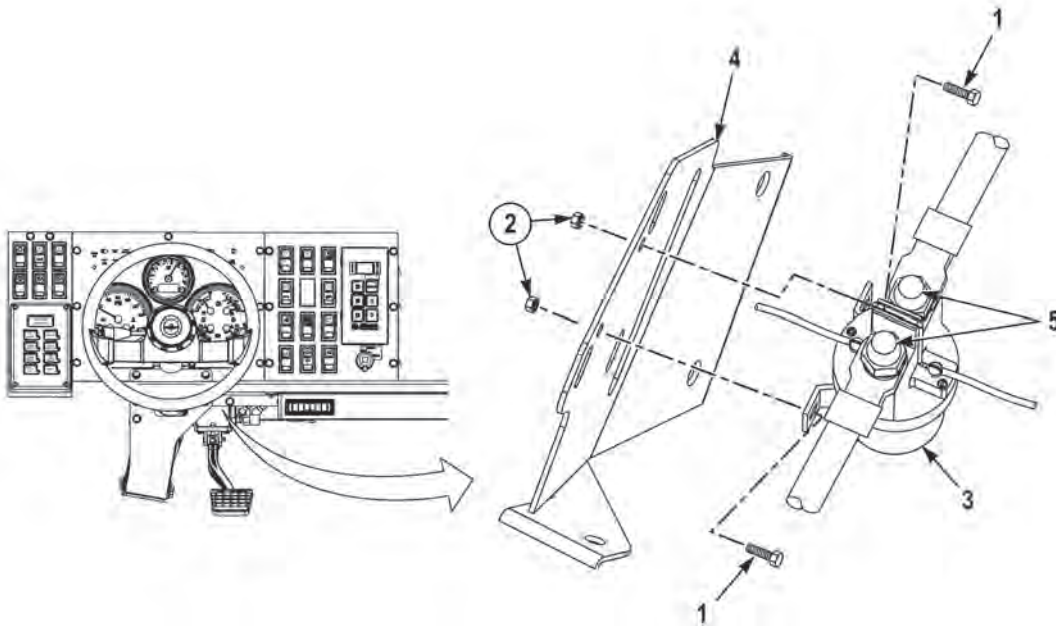

5. Install two rubber caps (5) on ignition relay (3).
6. Install ignition relay (3) on steering column (4) with two new locknuts (2) and screws (1).
7. Perform all Follow-On Maintenance tasks.

**END OF TASK**

**END OF WORK PACKAGE**

---

**INFRARED (IR) LIGHT REPLACEMENT (M1245)**

---

**Preconditions**

Park Vehicle  
 Engine OFF  
 Wheels Chocked  
 Batteries Disconnected (WP 0187)

**Tools and Special Tools**

Tool Kit, General Mechanic's: Automotive

**Materials/Parts**

Locknut (2) (Item 6)  
 Locknut (2) (Item 9)

**Follow-On Maintenance**

Batteries Disconnected (WP 0187)  
 Remove and Stow Wheel Chocks

---

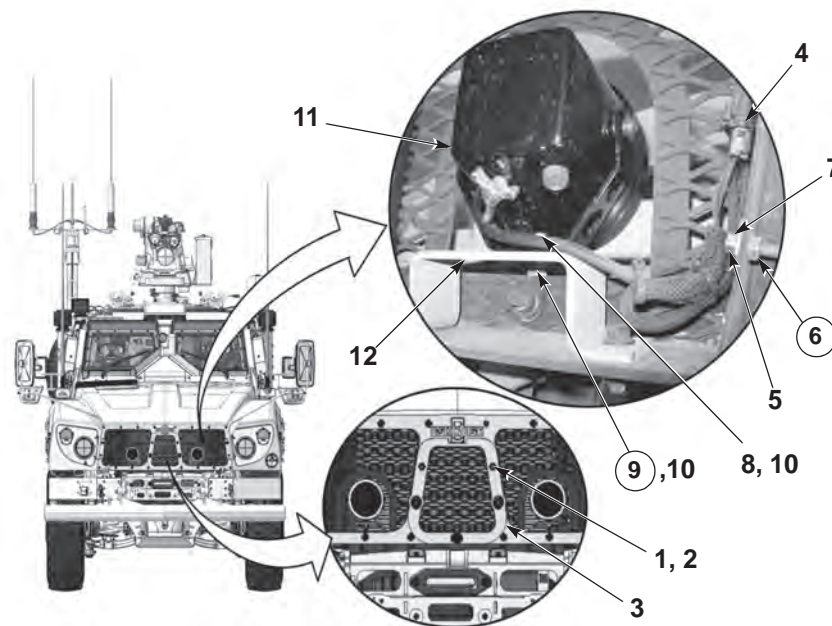
**REMOVAL****NOTE**

Removal procedure is the same for both driver side and passenger side IR lights.

1. Remove three screws (1) and three washers (2) from the center grill plate (3).
2. Disconnect infrared (IR) light electrical connector (4).
3. Remove screw (5) and locknut (6) from cushion clip (7). Discard locknut.
4. Remove locknut (8), two washers (10), and screw (9). Discard locknuts.
5. Remove IR light assembly (11) from bracket (12).

**END OF TASK**

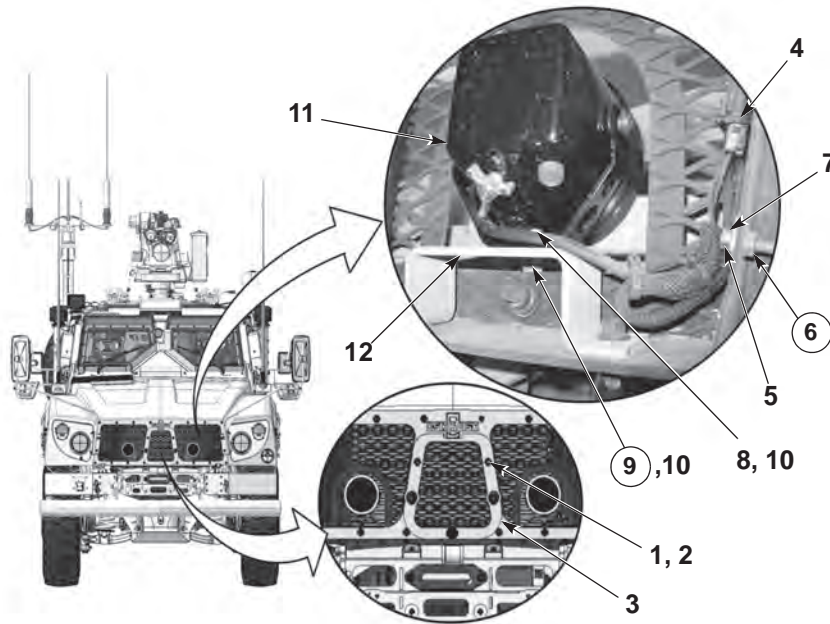
**INSTALLATION**

1. Position IR light assembly (11) from bracket (12).
2. Install two washers (10), screw (9), and locknut (8).
3. Install cushion clip (7), screw (5), and locknut (6).
4. Connect infrared (IR) light electrical connector (4).
5. Install center grill plate (3), three washers (2), and three screws (1).
6. Perform all Follow-On Maintenance Tasks.

**END OF TASK****END OF WORK PACKAGE**

---

**MK-44 RECEPTACLE REPLACEMENT (M1245)**

---

**Preconditions**

Park Vehicle  
 Engine OFF  
 Wheels Chocked  
 Batteries Disconnected (WP 0187)

**Materials/Parts**

Locknut (4) (Item 1)

**Follow-On Maintenance**

Batteries Disconnected (WP 0187)  
 Remove and Stow Wheel Chocks

**Tools and Special Tools**

Tool Kit, General Mechanic's: Automotive

---

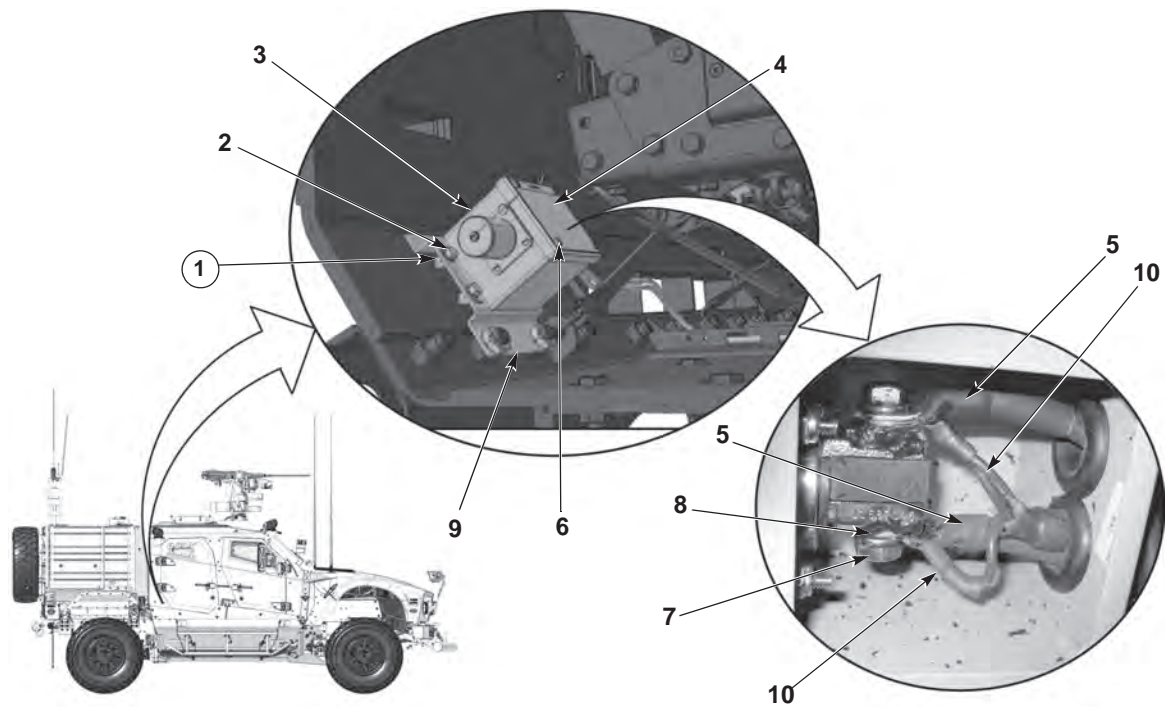
**REMOVAL**

1. Remove four screws (6) and receptacle cover (4).

**NOTE**

Note position of power cables prior to removal to ensure proper installation.

2. Remove two screws (7) and two washers (8).
3. Disconnect power cables (5), cables (10), and remove from Mk-44 receptacle (3) through grommets.
4. Remove four locknuts (1) and four screws (2). Discard locknuts.
5. Remove Mk-44 receptacle (3) from bracket (9).

**END OF TASK**

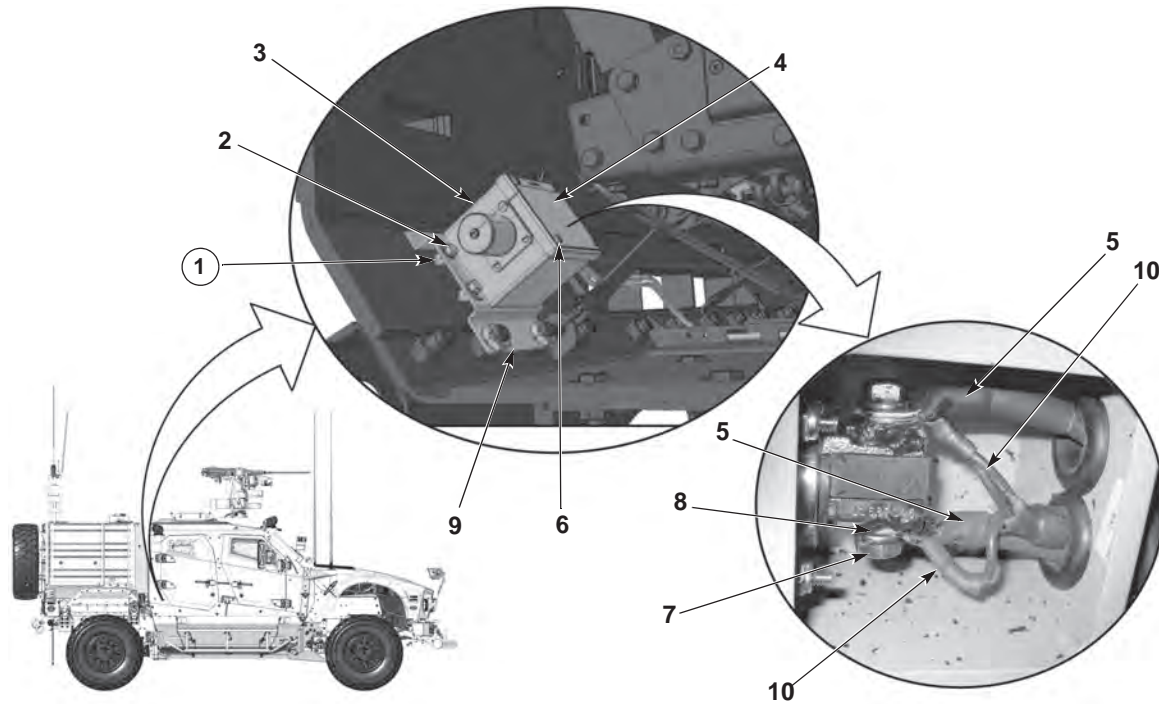
**INSTALLATION**

1. Position Mk-44 receptacle (3) on bracket (9).
2. Install four screws (2) and four new locknuts (1).

**NOTE**

Install power cables as noted prior to removal.

3. Position power cables (5), cables (10) and install two washers (8) and two screws (7).
4. Install receptacle cover (4) and four screws (6).
5. Perform all Follow-On Maintenance Tasks.

**END OF TASK**

**END OF WORK PACKAGE**



---

**NATO SLAVE RECEPTACLE REPLACEMENT (FOR VEHICLES WITH UPDATED SPARK OR M1245)**

---

**Preconditions**

Park vehicle  
 Engine OFF  
 Wheels chocked  
 Hood opened and secured  
 Batteries disconnected (M1240/M1240A1)  
 (WP 0186)  
 Batteries disconnected (M1245) (WP 0187)

**Tools and Special Tools**

Tool Kit, General Mechanic's: Automotive

**Materials/Parts**

Lockwasher (2) (Item 2 and 6)

**Material/Parts (continued)**

Locknut (4) (Item 8)  
 Gasket (Item 15)  
 Sealant, RTV Electric  
 Tags, Identification

**Follow-On Maintenance**

Connect batteries (M1240/M1240A1) (WP 0186)  
 Connect batteries (M1245) (WP 0187)  
 Close and secure hood  
 Remove and stow wheel chocks

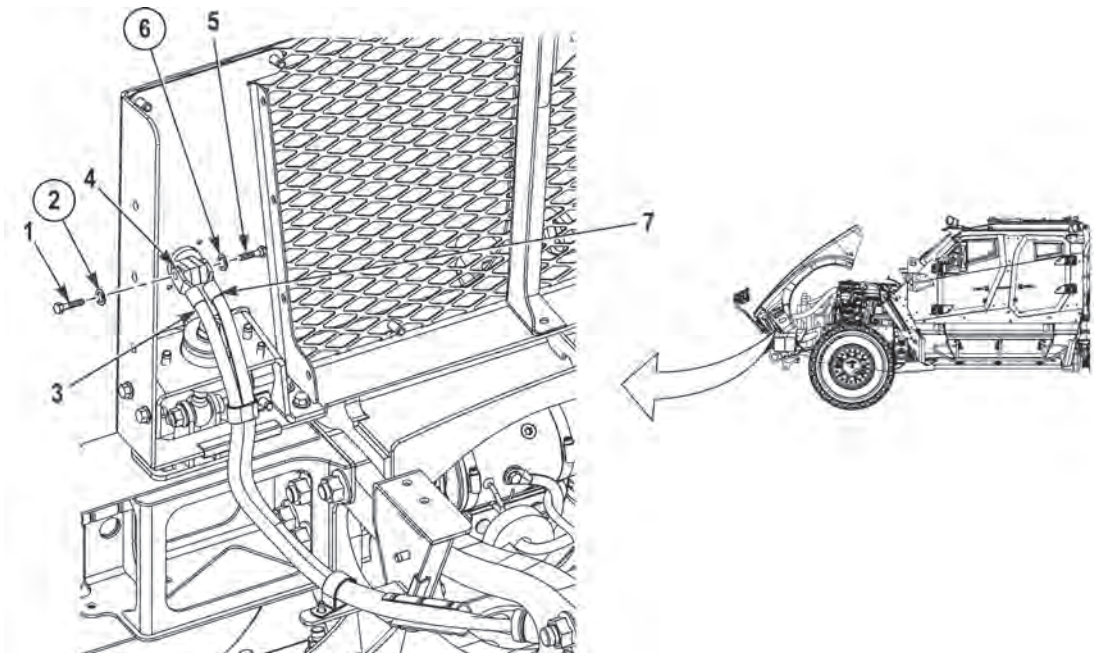
**REMOVAL****NOTE**

- Tag and mark cables prior to removal to ensure proper installation.
- NATO slave receptacle is marked with a + (positive) and a - (negative). Note position of cables prior to removal to ensure proper installation.

1. Remove screw (1), lockwasher (2), and cable (3) from negative terminal of NATO slave receptacle (4). Discard lockwasher (2).
2. Remove screw (5), lockwasher (6), and cable (7) from positive terminal of NATO slave receptacle (4). Discard lockwasher (6).

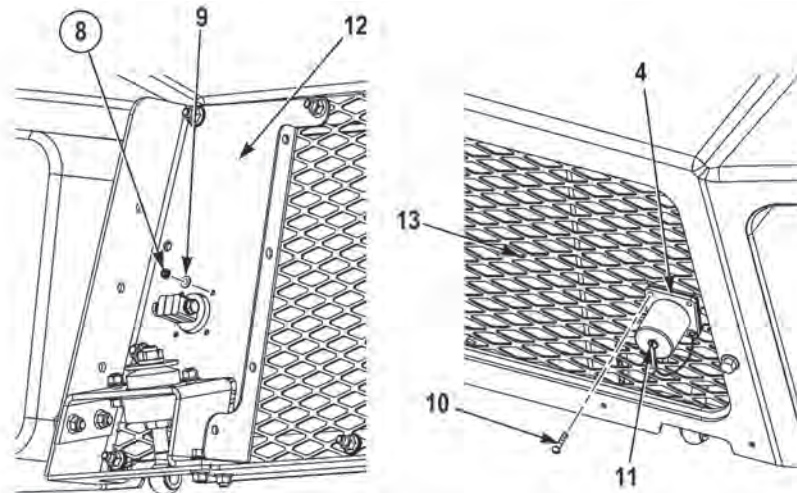

### NOTE

- Note placement of lanyard prior to removal to ensure proper installation.
  - Note position of NATO slave receptacle prior to removal to ensure proper installation.
3. Remove four locknuts (8), washers (9), screws (10), lanyard (11), and NATO slave receptacle (4) from driver side grill panel (12) and grill (13). Discard locknuts (8).

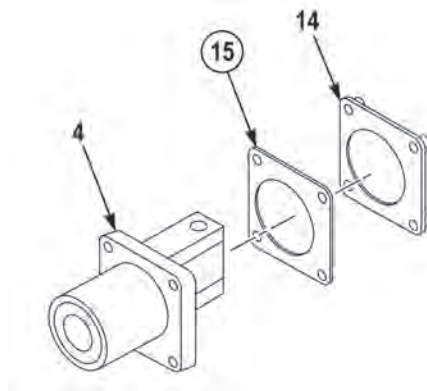

4. Remove insulator (14) and gasket (15) from NATO slave receptacle (4). Discard gasket (15).

### END OF TASK

### INSTALLATION

1. Install new gasket (15) and insulator (14) on NATO slave receptacle (4).

### NOTE

- Install lanyard as noted prior to removal.
- Install NATO slave receptacle as noted prior to removal.

2. Install NATO slave receptacle (4) and lanyard (11) on grill (13) and driver side grill panel (12) with four screws (10), washers (9), and new locknuts (8).

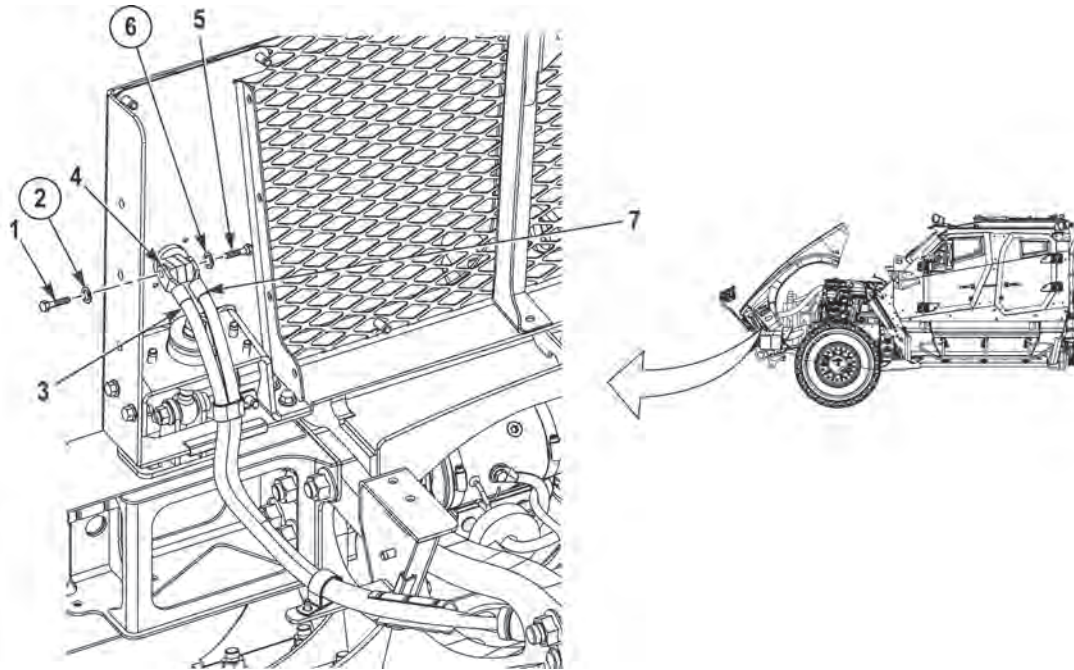

### **CAUTION**

Ensure cables are installed correctly on NATO slave receptacle. Terminal assembly is offset from center of receptacle. Positive terminal (red cable) is closest to the center of receptacle. Negative (black cable) is farther away from center of receptacle. Failure to comply may result in damage to equipment.

### **NOTE**

Install cables as noted prior to removal.

3. Install cable (7) on positive terminal of NATO slave receptacle (4) with new lockwasher (6) and screw (5).
4. Install cable (3) on negative terminal of NATO slave receptacle (4) with new lockwasher (2) and screw (1).

### **WARNING**

Adhesives, solvents, and sealing compounds can burn easily, can give off harmful vapors, and are harmful to skin and clothing. To avoid injury or death, keep away from open fire and use in well-ventilated area. If adhesive, solvent, or sealing compound gets on skin or clothing, wash immediately with soap and water. Failure to comply may result in injury or death to personnel.

5. Apply sealant, RTV to two screws (5 and 1), lockwashers (6 and 2), and cables (7 and 3).
6. Perform all Follow-On Maintenance tasks.

**END OF TASK**

**END OF WORK PACKAGE**



---

## PARKING BRAKE STOPLIGHT SWITCH REPLACEMENT

---

**Preconditions**

Park vehicle  
 Engine OFF  
 Wheels chocked  
 Air system drained  
 Batteries disconnected (M1240/M1240A1)  
 (WP 0186)  
 Batteries disconnected (M1245) (WP 0187)

**Materials/Parts**

Compound, Sealing, Loctite 592  
 Tags, Identification

**Follow-On Maintenance**

Connect batteries (M1240/M1240A1) (WP 0186)  
 Connect batteries (M1245) (WP 0187)  
 Remove and stow wheel chocks

**Tools and Special Tools**

Tool Kit, General Mechanic's: Automotive

---

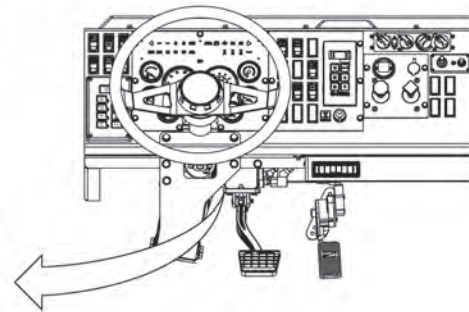
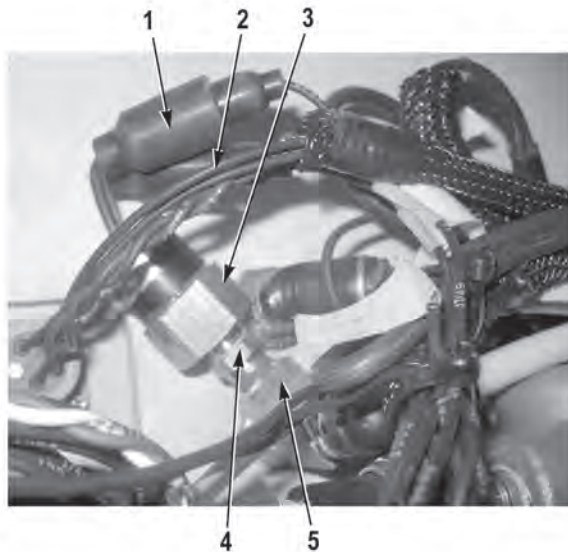
**REMOVAL****WARNING**

**Ensure air system is drained prior to working on air system components. Failure to comply may result in injury or death to personnel.**

**NOTE**

Tag and mark wires prior to removal to ensure proper installation.

1. Disconnect connector (1).
2. Disconnect connector (2).
3. Remove parking brake stoplight switch (3) from fitting (4).
4. Remove fitting (4) from fitting (5).

**END OF TASK**

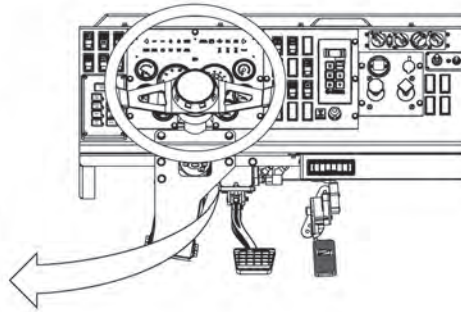
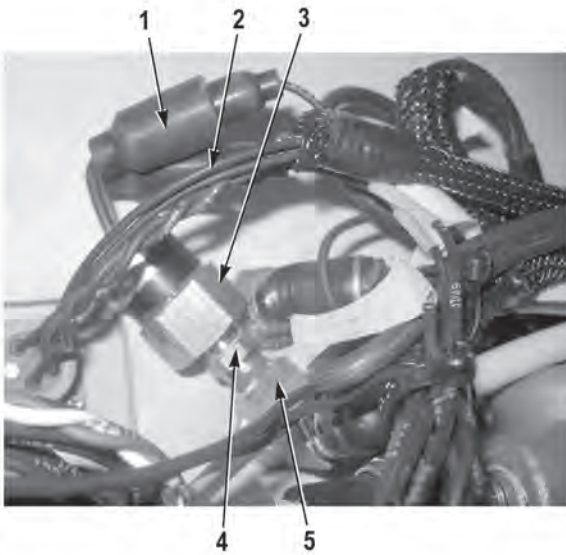
**INSTALLATION****WARNING**

Adhesives, solvents, and sealing compounds can burn easily, can give off harmful vapors, and are harmful to skin and clothing. To avoid injury or death, keep away from open fire and use in well-ventilated area. If adhesive, solvent, or sealing compound gets on skin or clothing, wash immediately with soap and water. Failure to comply may result in injury or death to personnel.

1. Apply sealing compound, Loctite 592, to threads of fitting (4) and parking brake stoplight switch (3).
2. Install fitting (4) on fitting (5).
3. Install parking brake stoplight switch (3) on fitting (4).

**NOTE**

Install wires as noted prior to removal for proper installation.

4. Connect connector (2).
5. Connect connector (1).
6. Perform all Follow-On Maintenance tasks.

**END OF TASK**

**END OF WORK PACKAGE**



---

**PDU DECK BOX REPLACEMENT (M1245)**

---

**Preconditions**

Park Vehicle  
 Engine OFF  
 Wheels Chocked  
 Batteries Disconnected (WP 0187)

**Tools and Special Tools**

Tool Kit, General Mechanic's: Automotive  
 Crowfoot Wrench, 7/16" - 3/8" Drive

**Materials/Parts**

Lockwasher (2) (Item 4)  
 Locknut (4) (Item 5)  
 Tags

**Follow-On Maintenance**

Batteries Disconnected (WP 0187)  
 Remove and Stow Wheel Chocks

---

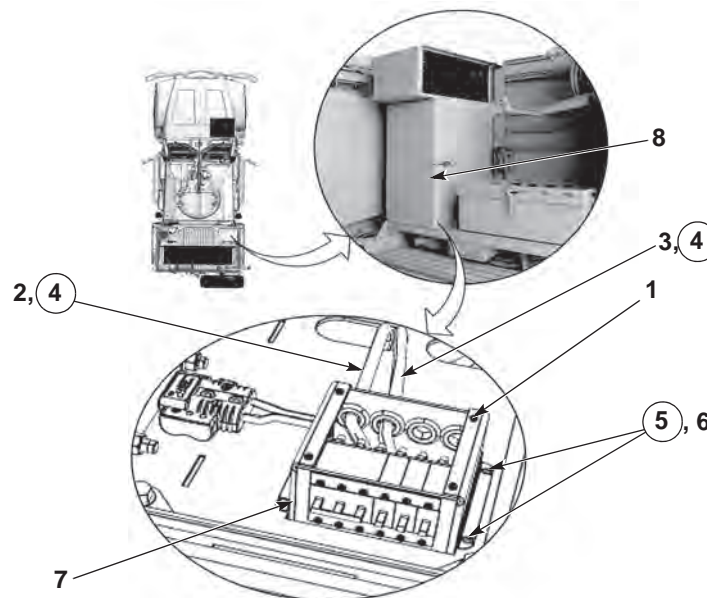
**REMOVAL****NOTE**

- Tag and mark wires and cables and note all wire harness and cable routing prior to removal to ensure proper installation.
- Right side GFE cabinet may be removed for additional access to lockwashers and screws.

1. Remove four screws (1) and lift PDU cover off.
2. Disconnect cable 1141(2) and cable 1436 (3) from PDU (6) and route through PDU cable opening. Discard lockwashers (4).
3. Remove four locknuts (5) and four screws (6) from PDU (7). Discard locknuts (5).
4. Lift and remove PDU (7) from inside passenger side GFE cabinet (8).

**END OF TASK**

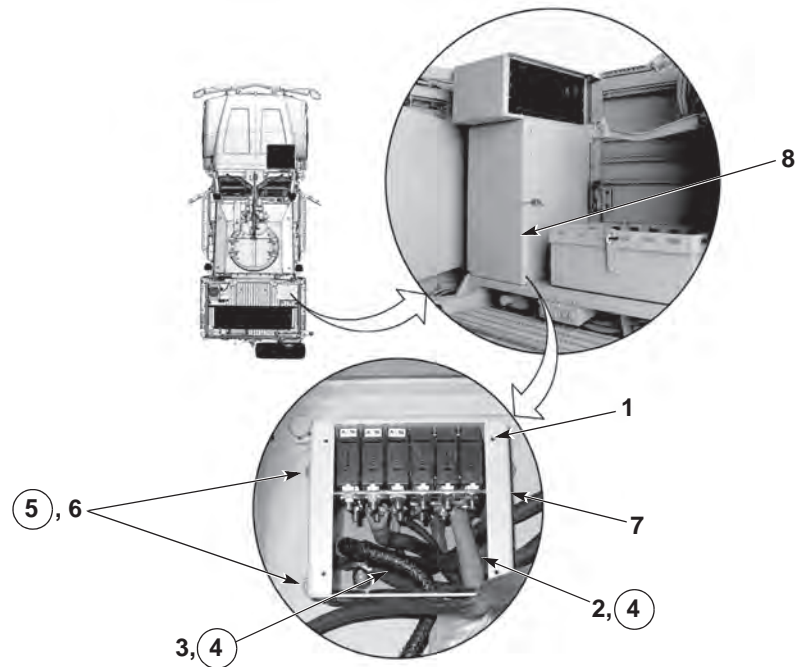

**INSTALLATION**

1. Install PDU (7) into passenger side GFE cabinet (8).
2. Install four screws (6) and four new locknuts (5), securing PDU (7) to passenger side GFE cabinet (8).

**NOTE**

Install cables as noted prior to removal.

3. Connect cable 1141 (2) and cable 1436 (3) to PDU (6) with two new lockwashers (4).
4. Install PDU cover and secure with four screws (1).
5. Perform all Follow-On Maintenance Tasks.

**END OF TASK**

**END OF WORK PACKAGE**

---

**PRESSURE SWITCH REPLACEMENT**

---

**Preconditions**

- Park vehicle
- Engine OFF
- Wheels chocked
- Air system drained
- Batteries disconnected (M1240/M1240A1) (WP 0186)
- Batteries disconnected (M1245) (WP 0187)

**Tools and Special Tools**

- Tool Kit, General Mechanic's: Automotive

**Materials/Parts**

- Cap and Plug Set
- Compound, Sealing, Loctite 592
- Tags, Identification

**Follow-On Maintenance**

- Connect batteries (M1240/M1240A1) (WP 0186)
- Connect batteries (M1245) (WP 0187)
- Remove and stow wheel chocks

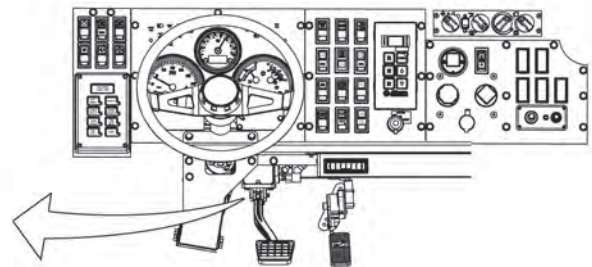
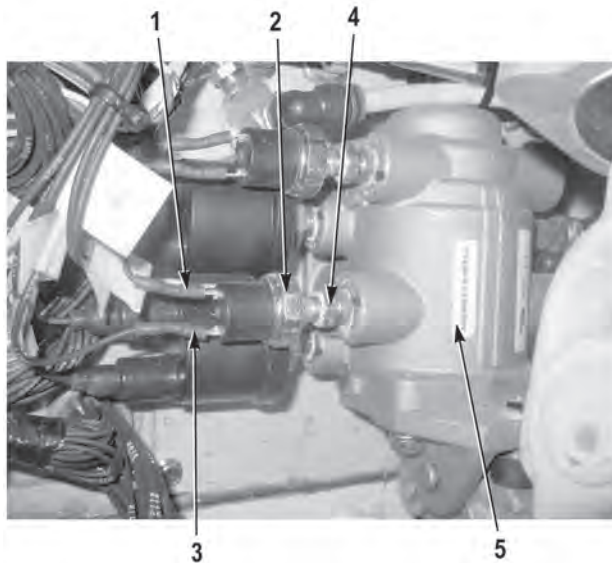
**REMOVAL****WARNING**

Ensure air system is drained prior to working on air system components. Failure to comply may result in injury or death to personnel.

**NOTE**

- Both pressure switches are removed the same way.
  - Tag and mark wires prior to removal to ensure proper installation.
1. Disconnect connector (1) from pressure switch (2).
  2. Disconnect connector (3) from pressure switch (2).
  3. Remove pressure switch (2) from fitting (4).

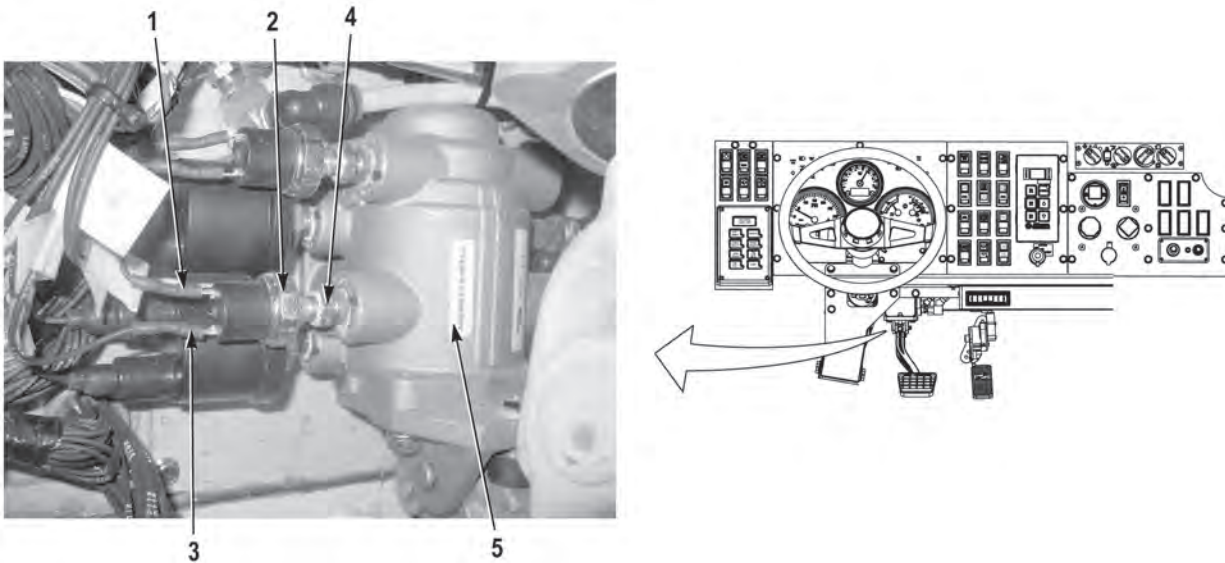
**NOTE**

Perform Step (4) if fitting is damaged.

4. Remove fitting (4) from treadle valve (5).

**END OF TASK****INSTALLATION****WARNING**

**Adhesives, solvents, and sealing compounds can burn easily, can give off harmful vapors, and are harmful to skin and clothing. To avoid injury or death, keep away from open fire and use in well-ventilated area. If adhesive, solvent, or sealing compound gets on skin or clothing, wash immediately with soap and water. Failure to comply may result in injury or death to personnel.**

1. Apply sealing compound, Loctite 592, to threads of fitting (4) and pressure switch (2).

**NOTE**

Both pressure switches are installed the same way.

2. Install fitting (4) on treadle valve (5).
3. Install pressure switch (2) on fitting (4).

**NOTE**

Install wires as noted prior to removal.

4. Install connector (3) on pressure switch (2).
5. Install connector (1) on pressure switch (2).
6. Perform all Follow-On Maintenance tasks.

**END OF TASK**

**END OF WORK PACKAGE**



---

## REAR COMPOSITE LIGHT REPLACEMENT

---

**Preconditions**

Park vehicle  
 Engine OFF  
 Wheels chocked  
 Batteries disconnected (M1240/M1240A1)  
 (WP 0186)  
 Batteries disconnected (M1245) (WP 0187)

**Tools and Special Tools**

Tool Kit, General Mechanic's: Automotive

**Materials/Parts**

Lockwasher (6) (Item 4)  
 Tags, Identification  
 Ties, Cable

**Follow-On Maintenance**

Connect batteries (M1240/M1240A1) (WP 0186)  
 Connect batteries (M1245) (WP 0187)  
 Remove and stow wheel chocks

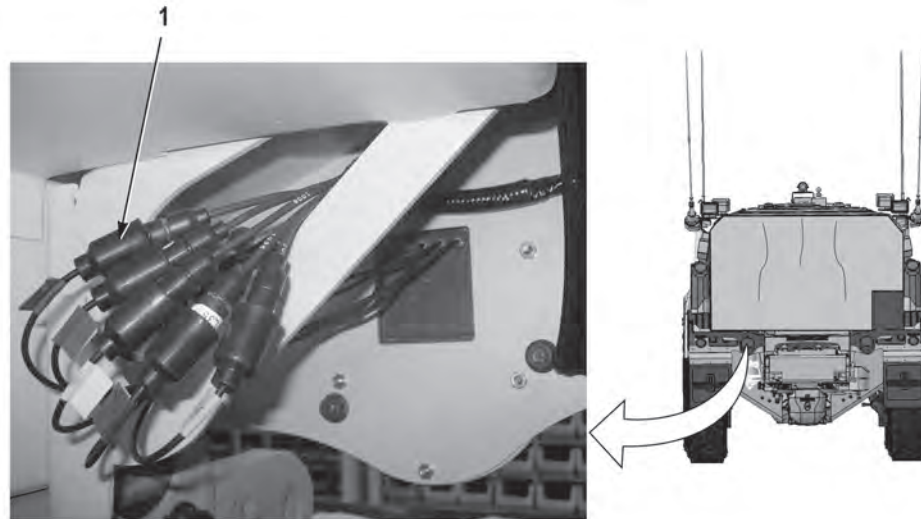
**REMOVAL****NOTE**

- Both rear composite lights are removed the same way. Driver side shown.
- Tag and mark wires prior to removal to ensure proper installation.
- Remove cable ties as required.

1. Disconnect five connectors (1).

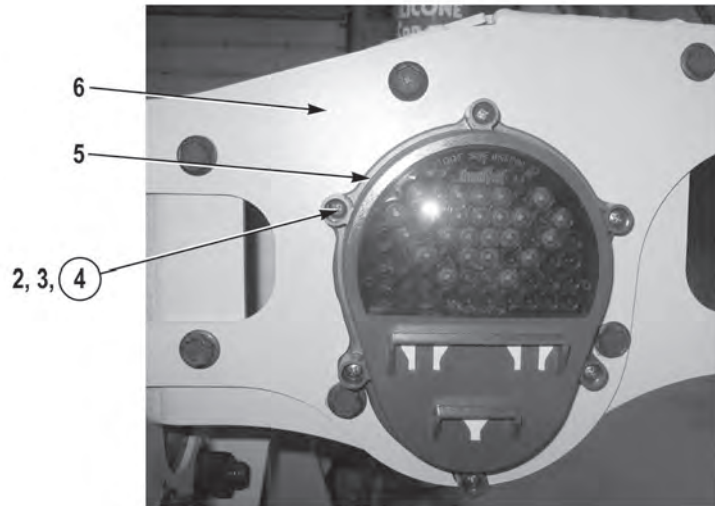

2. Remove six screws (2), nuts (3), lockwashers (4), and composite light (5) from bumper (6). Discard lockwashers (4).

#### END OF TASK

#### INSTALLATION

#### NOTE

- Both rear composite lights are installed the same way. Driver side shown.
  - Install wires as noted prior to removal.
  - Install cable ties as required.
1. Install composite light (5) on bumper (6) with six screws (2), new lockwashers (4), and nuts (3).



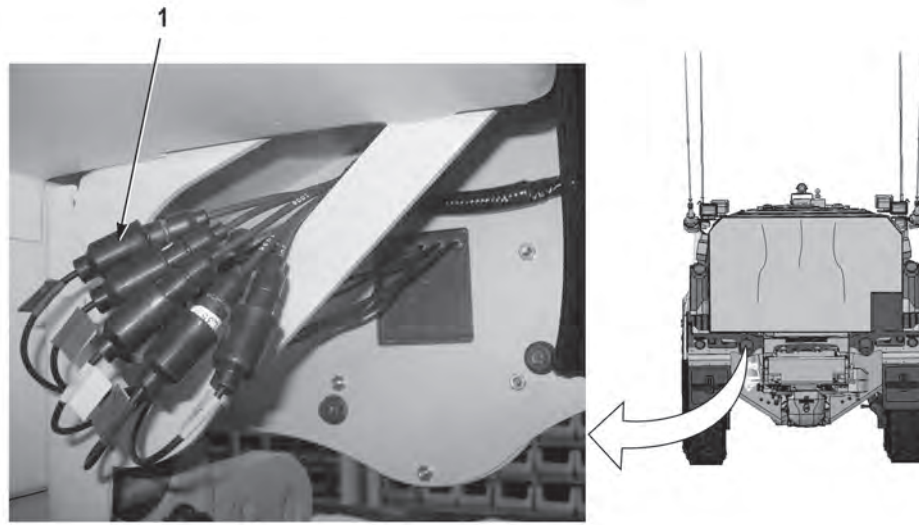

2. Connect five connectors (1).
3. Perform all Follow-On Maintenance tasks.

**END OF TASK**

**END OF WORK PACKAGE**



---

**REVERSE LIGHT REPLACEMENT (M1240/M1240A1)**

---

**Preconditions**

Park vehicle  
Engine OFF  
Wheels chocked  
Batteries disconnected (WP 0186)

**Tools and Special Tools**

Tool Kit, General Mechanic's: Automotive

**Materials/Parts**

Locknut (Item 2)  
Lubricant, Connector, Nyogel 760G

**Follow-On Maintenance**

Connect batteries (WP 0186)  
Remove and stow wheel chocks

---

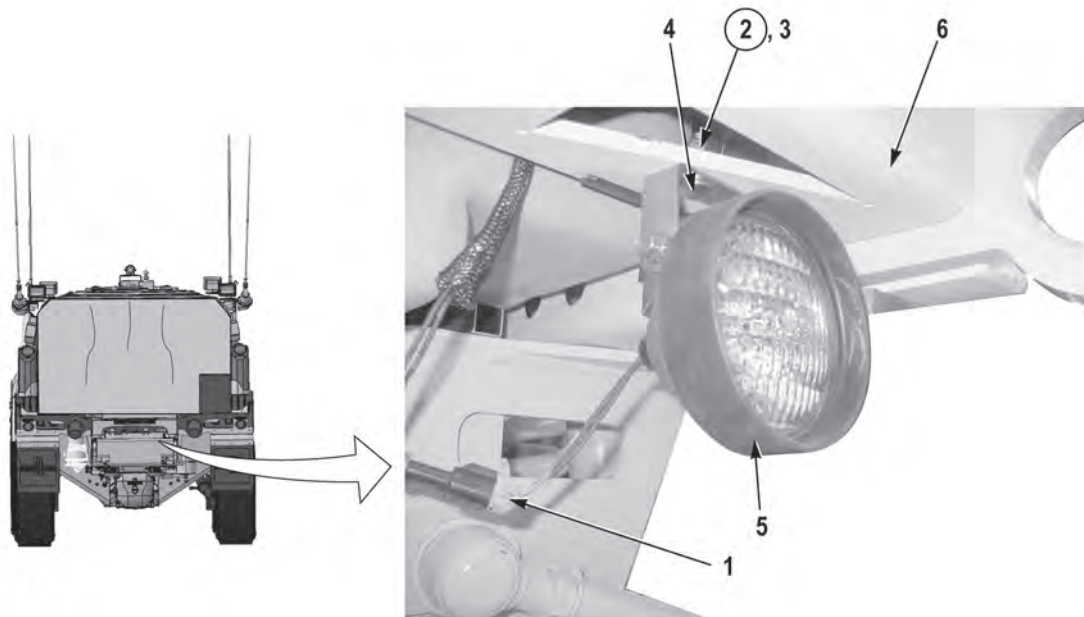
**REMOVAL**

1. Disconnect connector (1).
2. Remove locknut (2), washer (3), screw (4), and reverse light (5) from rear crossmember (6). Discard locknut (2).

**END OF TASK**

**INSTALLATION****WARNING**

Connector lubricant is harmful to skin. Prolonged or repeated contact with skin or contact with eyes may cause irritation. If eyes are contacted, rinse thoroughly and contact physician if irritation persists. If skin is contacted, wash thoroughly with soap and water. Failure to comply may result in injury or death to personnel.

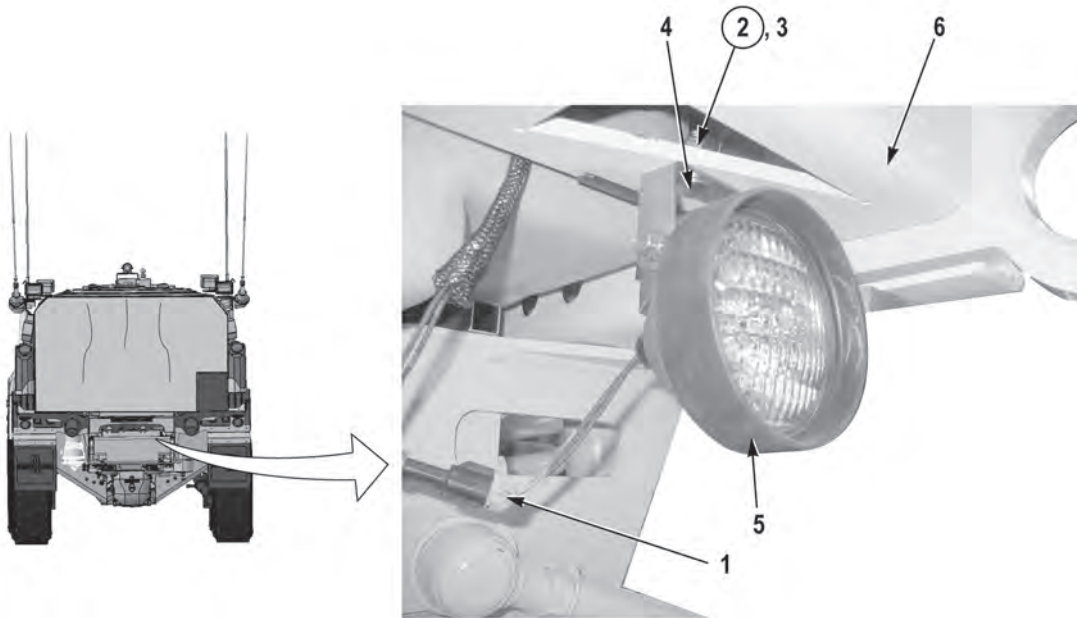

1. Install reverse light (5) on rear cross-member (6) with screw (4), washer (3), and new locknut (2).
2. Apply connector lubricant, Nyogel 760G, to connector (1).
3. Connect connector (1).
4. Perform all Follow-On Maintenance tasks.

**END OF TASK****END OF WORK PACKAGE**

---

## SPOTLIGHT CONTROLLER REPLACEMENT

---

**Preconditions**

Park vehicle  
 Engine OFF  
 Wheels chocked  
 Batteries disconnected (M1240/M1240A1)  
 (WP 0186)  
 Batteries disconnected (M1245) (WP 0187)

**Tools and Special Tools**

Tool Kit, General Mechanic's: Automotive

**Materials/Parts**

Compound, Sealing, Loctite 242  
 Lubricant, Connector, Nyogel 760G  
 Tags, Identification

**Follow-On Maintenance**

Connect batteries (M1240/M1240A1) (WP 0186)  
 Connect batteries (M1245) (WP 0187)  
 Remove and stow wheel chocks

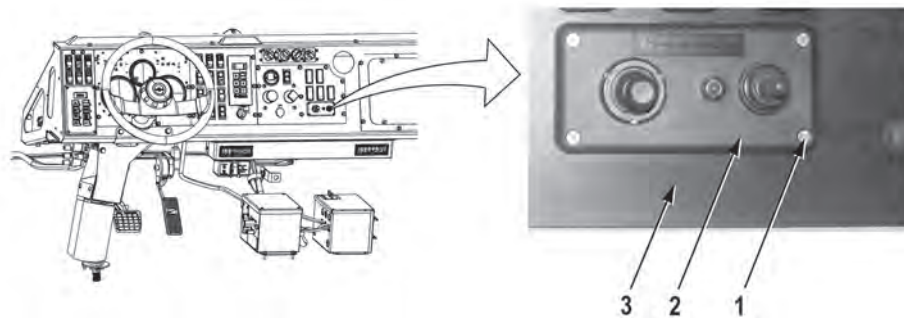
**REMOVAL****NOTE**

- Perform Steps (1) and (2) to remove front spotlight controller.
  - Perform Steps (3) and (4) to remove rear spotlight controller.
1. Remove four screws (1) and front spotlight controller (2) from dash (3).

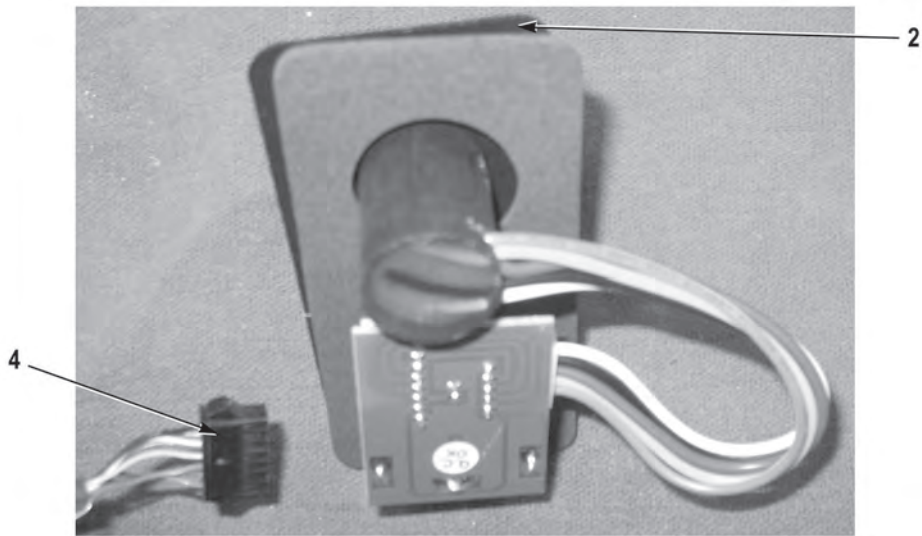
**NOTE**

Tag and mark wire connectors prior to removal to ensure proper installation.

2. Disconnect connector (4) from front spotlight controller (2).

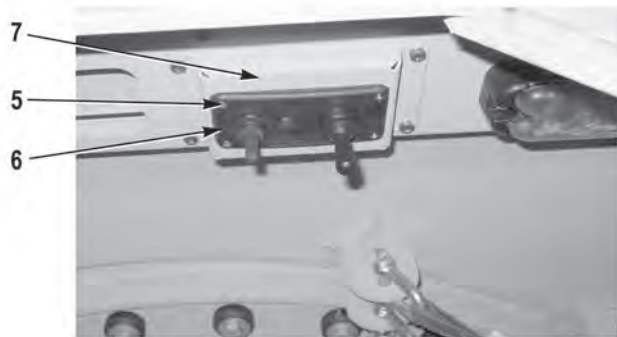

3. Remove four screws (5) and rear spotlight controller (6) from bracket (7).

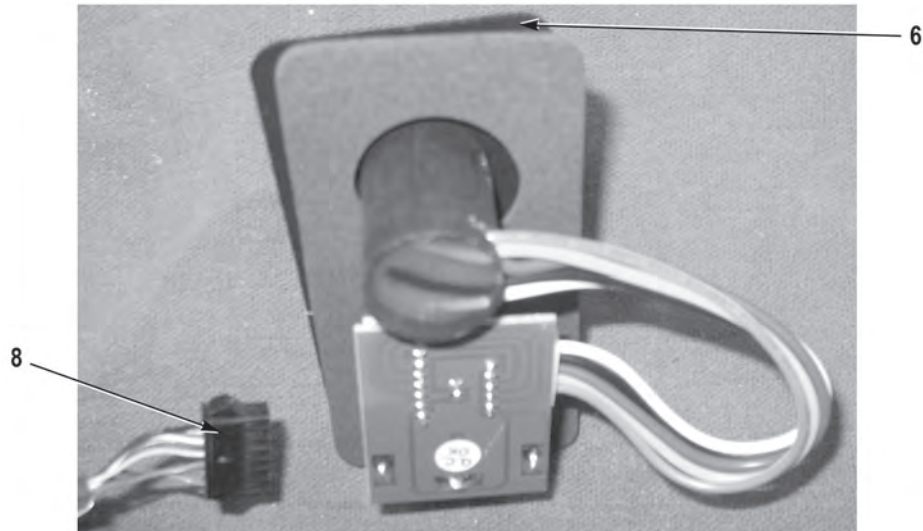

### NOTE

Tag and mark wire connectors prior to removal to ensure proper installation.

4. Disconnect connector (8) from rear spotlight controller (6).

### END OF TASK

### INSTALLATION

### WARNING

**Connector lubricant is harmful to skin. Prolonged or repeated contact with skin or contact with eyes may cause irritation. If eyes are contacted, rinse thoroughly and contact physician if irritation persists. If skin is contacted, wash thoroughly with soap and water. Failure to comply may result in injury or death to personnel.**

### NOTE

- Perform Steps (1) through (4) to install rear spotlight controller.
  - Perform Steps (5) through (8) to install front spotlight controller.
1. Apply connector lubricant, Nyogel 760G, to connector (8).
  2. Connect connector (8) to rear spotlight controller (6).



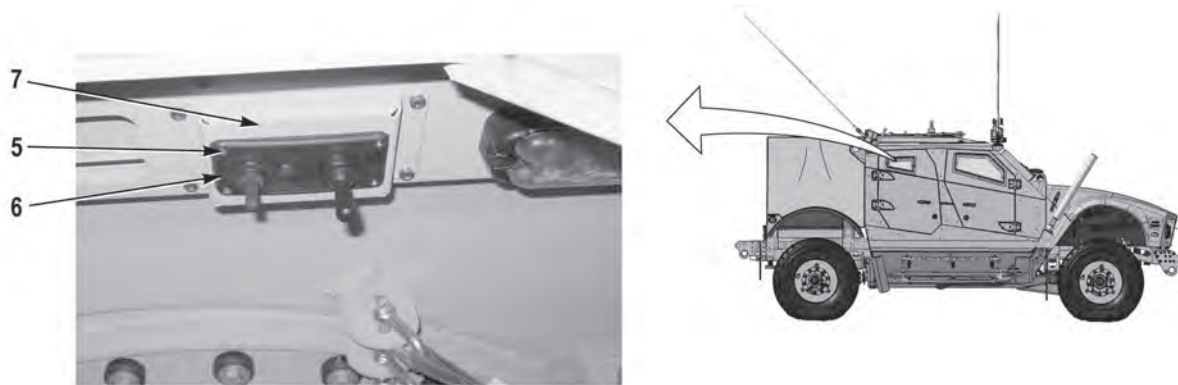

### **WARNING**

Adhesives, solvents, and sealing compounds can burn easily, can give off harmful vapors, and are harmful to skin and clothing. To avoid injury or death, keep away from open fire and use in well-ventilated area. If adhesive, solvent, or sealing compound gets on skin or clothing, wash immediately with soap and water. Failure to comply may result in injury or death to personnel.

3. Apply sealing compound, Loctite 242, to threads of four screws (5).
4. Install rear spotlight controller (6) on bracket (7) with four screws (5).

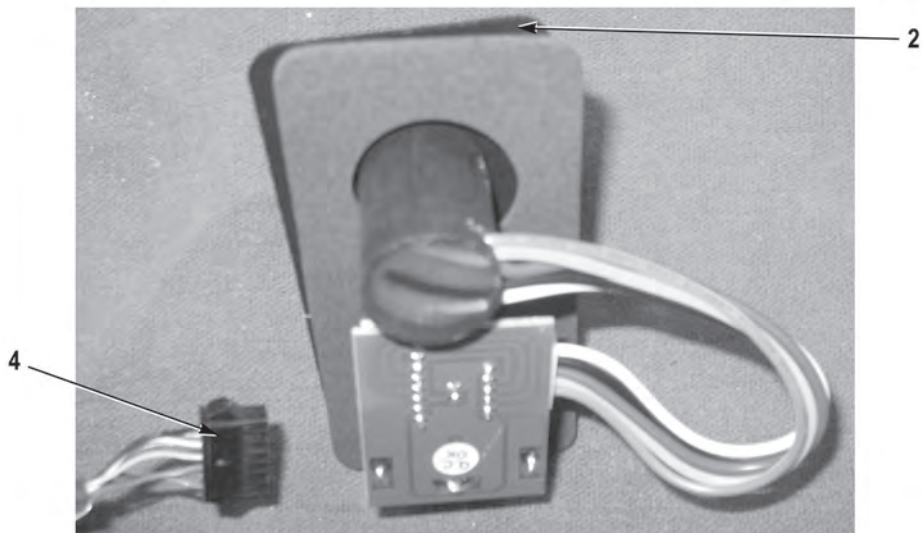

### **WARNING**

Connector lubricant is harmful to skin. Prolonged or repeated contact with skin or contact with eyes may cause irritation. If eyes are contacted, rinse thoroughly and contact physician if irritation persists. If skin is contacted, wash thoroughly with soap and water. Failure to comply may result in injury or death to personnel.

5. Apply connector lubricant, Nyogel 760G, to connector (4).
6. Connect connector (4) to front spotlight controller (2).

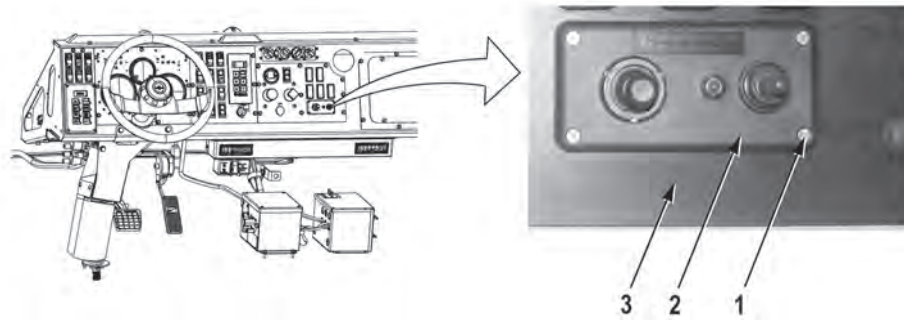

### NOTE

Adhesives, solvents, and sealing compounds can burn easily, can give off harmful vapors, and are harmful to skin and clothing. To avoid injury or death, keep away from open fire and use in well-ventilated area. If adhesive, solvent, or sealing compound gets on skin or clothing, wash immediately with soap and water. Failure to comply may result in injury or death to personnel.

7. Apply sealing compound, Loctite 242, to threads of four screws (1).
8. Install front spotlight controller (2) on dash (3) with four screws (1).
9. Perform all Follow-On Maintenance tasks.

**END OF TASK**

**END OF WORK PACKAGE**



---

**SPOTLIGHT REPLACEMENT**

---

**Preconditions**

Park vehicle  
 Engine OFF  
 Wheels chocked  
 Batteries disconnected (M1240/M1240A1)  
 (WP 0186)  
 Batteries disconnected (M1245) (WP 0187)

**Tools and Special Tools**

Tool Kit, General Mechanic's: Automotive

**Materials/Parts**

Adhesive, RTV, Silicone  
 Locknut (4) (Item 1)  
 Tags, Identification  
 Ties, Cable

**Follow-On Maintenance**

Connect batteries (M1240/M1240A1) (WP 0186)  
 Connect batteries (M1245) (WP 0187)  
 Remove and stow wheel chocks

---

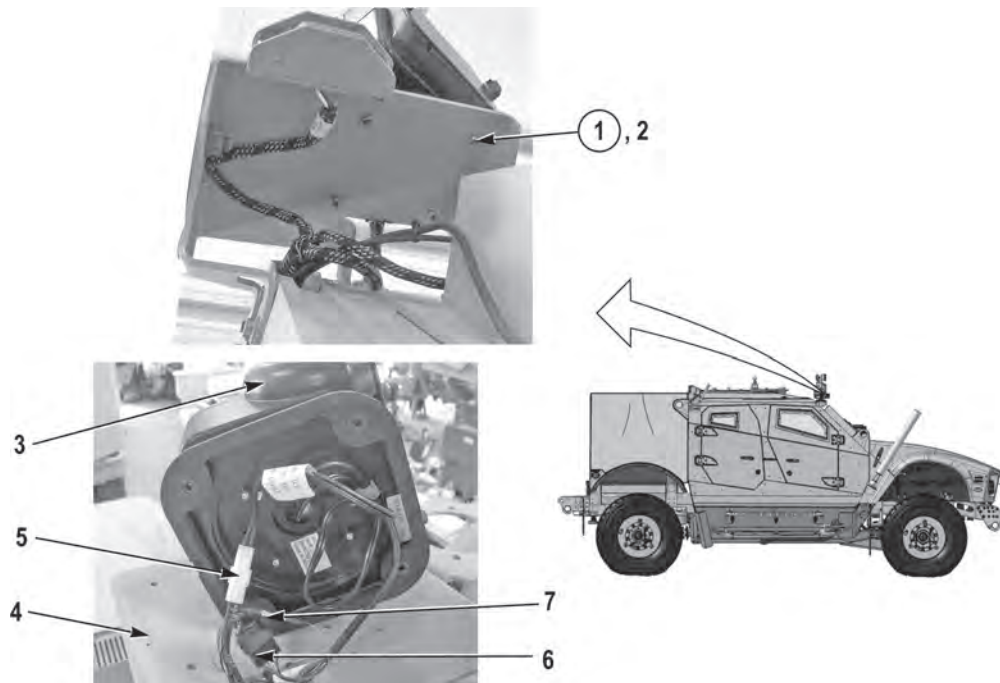
**REMOVAL****NOTE**

- All four spotlights are removed the same way. Passenger side front spotlight shown.
- Tag and mark wires prior to removal to ensure proper installation.
- Remove cable ties as required.

1. Remove four locknuts (1), screws (2), and spotlight (3) from bracket (4). Discard four locknuts (1).
2. Disconnect three connectors (5, 6, and 7).

**END OF TASK**

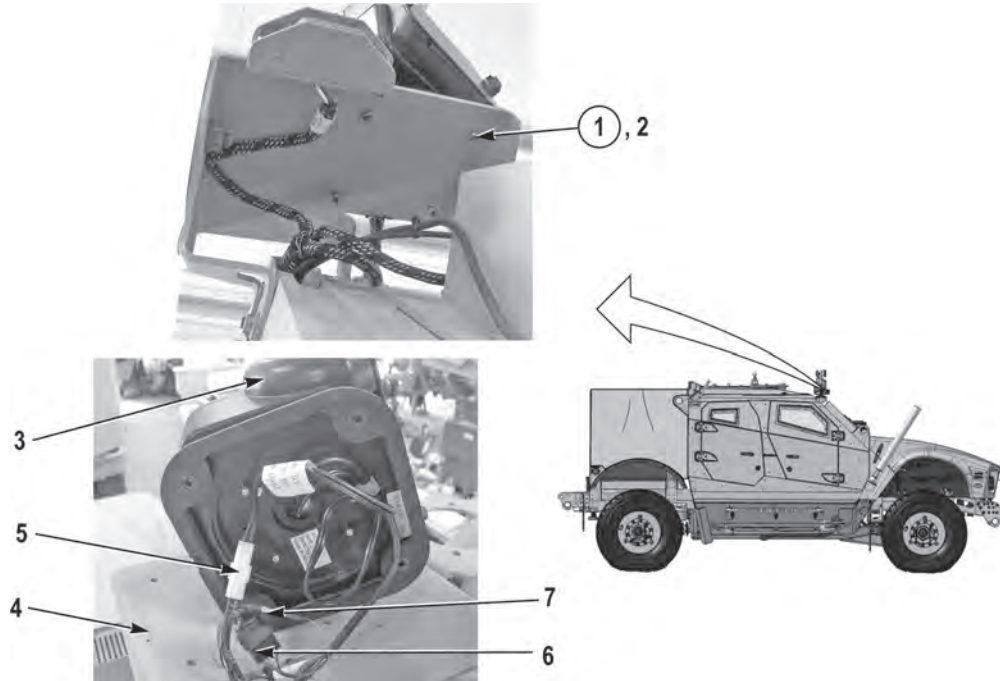
**INSTALLATION**

1. Connect three connectors (7, 6, and 5).
2. Install spotlight (3) on bracket (4) with four screws (2) and new locknuts (1).

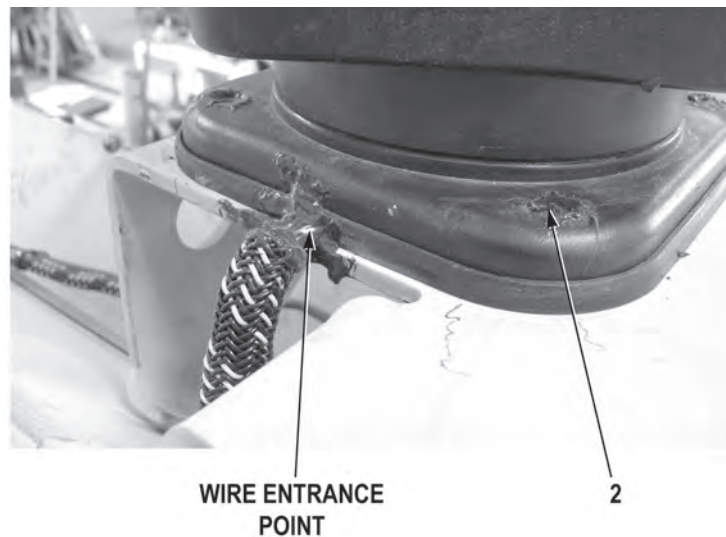

3. Apply adhesive, RTV to heads of four screws (2) and wire entrance point.
4. Perform all Follow-On Maintenance tasks.

**END OF TASK****END OF WORK PACKAGE**

---

**STARTER REPLACEMENT**

---

**Preconditions**

Park vehicle  
 Engine OFF  
 Wheels chocked  
 Batteries disconnected (M1240/M1240A1)  
 (WP 0186)  
 Batteries disconnected (M1245) (WP 0187)  
 Power steering pump removed (WP 0276)

**Tools and Special Tools**

Tool Kit, General Mechanic's: Automotive  
 Wrench, Combination, 1-1/16 in.  
 Wrench, Combination, 1-1/8 in.  
 Wrench, Combination, 1-5/16 in.

**Materials/Parts**

Locknut (Item 10)

**Materials/Parts (continued)**

Locknut (2) (Item 45 and 49)  
 Lockwasher (3) (Item 53)  
 Cap and Plug Set  
 Compound, Sealing, Loctite 592  
 Compound, Sealing, Novagard 200-257  
 Tags, Identification  
 Ties, Cable

**Personnel Required**

Two

**Follow-On Maintenance**

Install power steering pump (WP 0276)  
 Connect batteries (M1240/M1240A1) (WP 0186)  
 Connect batteries (M1245) (WP 0187)  
 Remove and stow wheel chocks

---

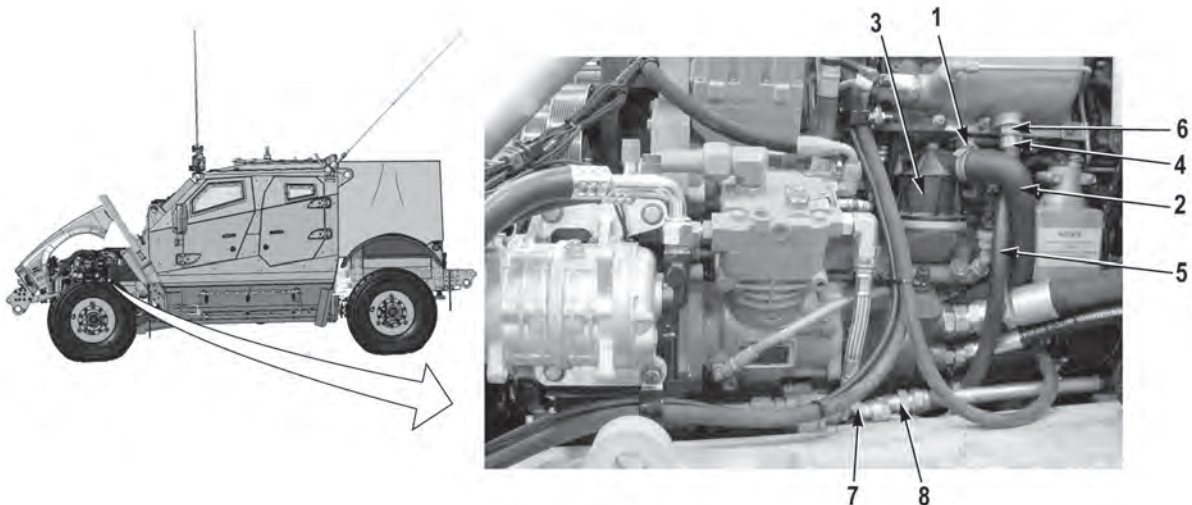
**REMOVAL****NOTE**

- Tag and mark hoses and fittings prior to removal to ensure proper installation.
- Cap and plug hoses and fittings upon removal.
- Remove cable ties as required.
- Perform Steps (1) through (7) for vehicles with 90 degree compressor outlet fitting.

1. Remove clamp (1) and hose (2) from breather assembly (3).
2. Remove clamp (4) and hose (5) from fitting (6).
3. Remove hose (7) from fitting (8).



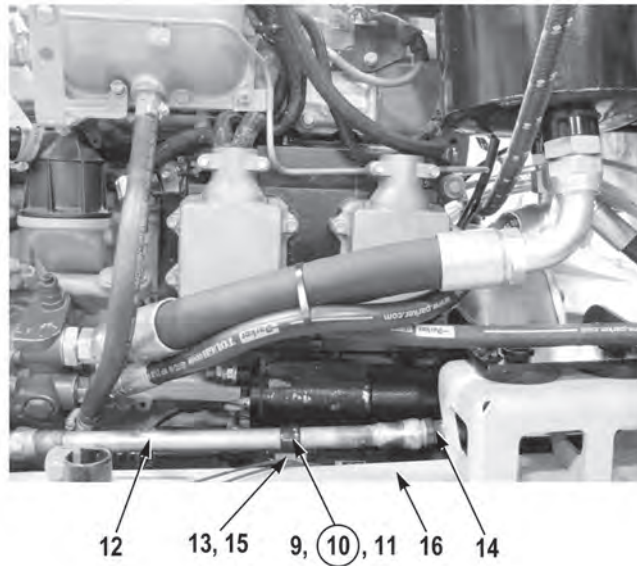

4. Remove screw (9), locknut (10), cushion clip (11), and tube (12) from bracket (13). Discard locknut (10).
5. Remove tube (12) from tube (14).
6. Remove screw (15) and bracket (13) from frame rail (16).

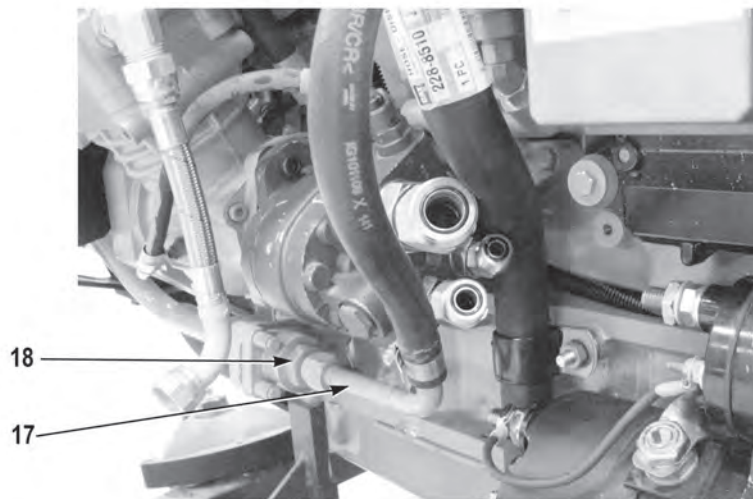

7. Remove tube (17) from fitting (18).



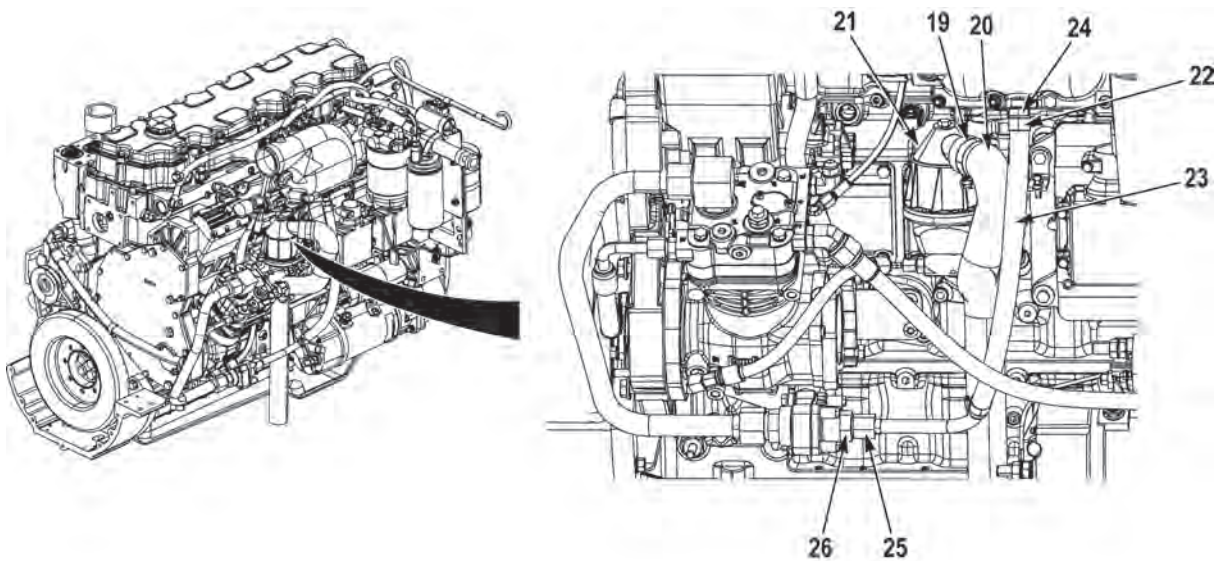

### NOTE

Perform Steps (8) through (13) for vehicles with 45 degree compressor outlet fitting.

8. Remove clamp (19) and hose (20) from breather assembly (21).
9. Remove clamp (22) and hose (23) from fitting (24).
10. Remove tube (25) from fitting (26).

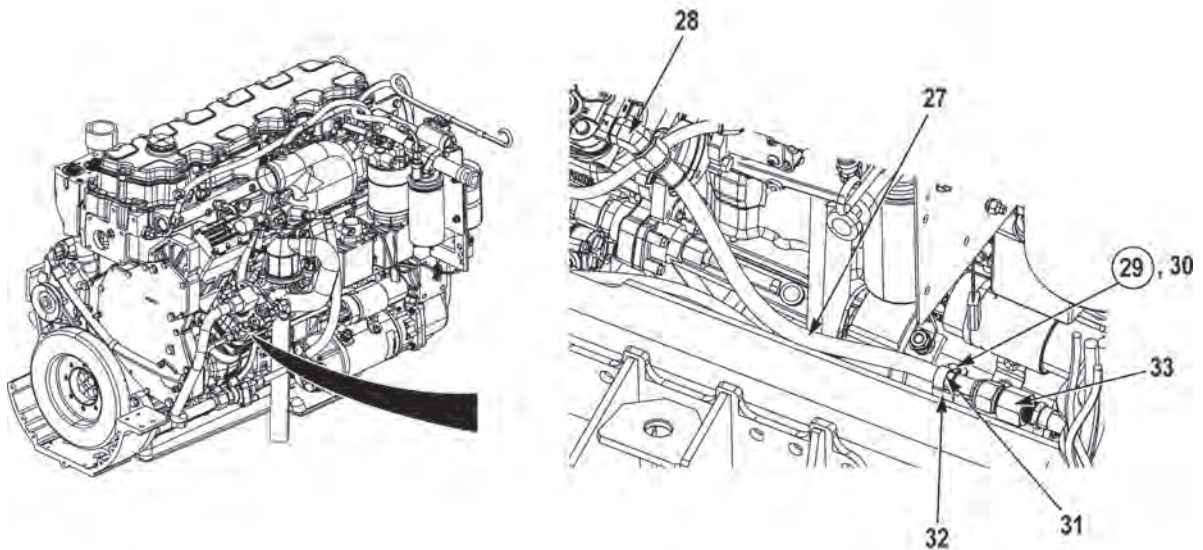

11. Remove hose (27) from fitting (28).
12. Remove locknut (29), screw (30), cushion clip (31), and hose (27) from standoff bracket (32). Discard locknut (29).
13. Remove hose (27) from fitting (33).

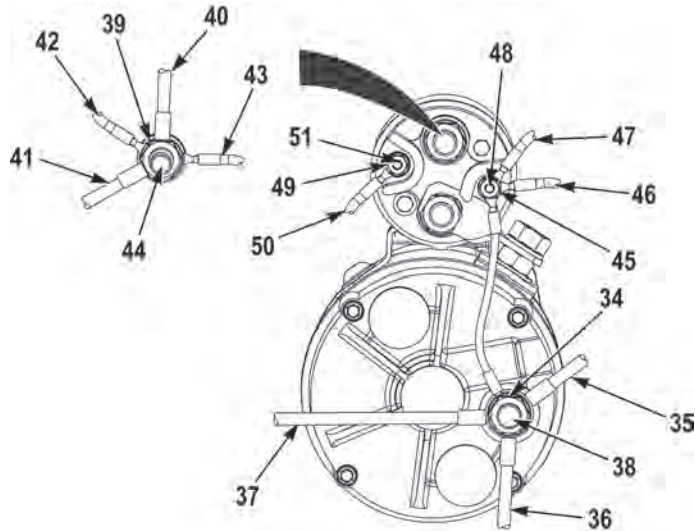

### NOTE

- Tag and mark cables and wires prior to removal to ensure proper installation.
  - Ground wire going from ground stud to solenoid should remain with starter assembly.
14. Remove nut (34) and three cables (35, 36, and 37) from starter ground stud (38).
  15. Remove nut (39), two cables (40 and 41) and two wires (42 and 43) from solenoid stud (44).
  16. Remove locknut (45) and two wires (46 and 47) from solenoid stud (48). Discard locknut (45).
  17. Remove locknut (49) and wire (50) from solenoid stud (51). Discard locknut (49).

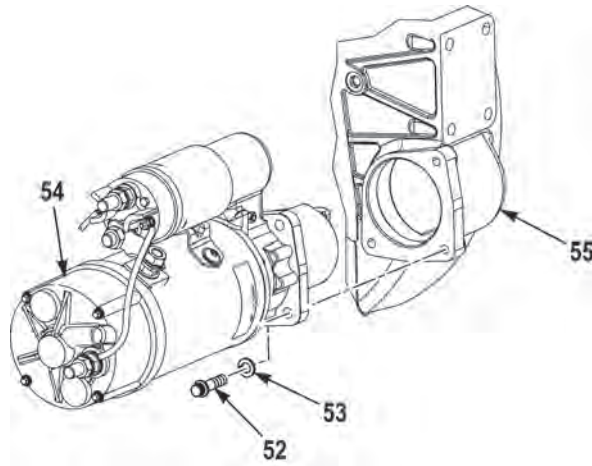
**WARNING**

**Starter weighs 50 lbs (23kg). Do not lift or move starter without the aid of an assistant. Failure to comply may result in injury to personnel.**

18. With the aid of an assistant, remove three screws (52), lockwashers (53), and starter assembly (54) from engine (55). Discard lockwashers (53).

**END OF TASK****INSTALLATION****WARNING**

**Starter weighs 50 lbs (23kg). Do not lift or move starter without the aid of an assistant. Failure to comply may result in injury to personnel.**

1. With the aid of an assistant, install starter assembly (54) on engine (55) with three new lockwashers (53) and screws (52).

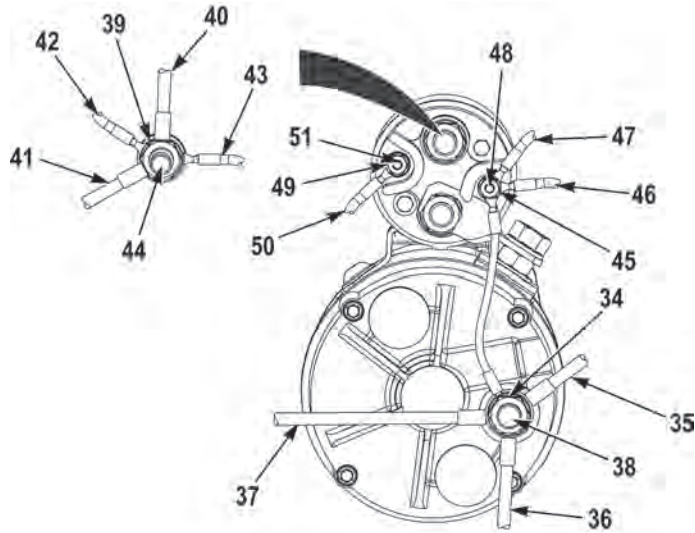

2. Install wire (50) on solenoid stud (51) with new locknut (49).
3. Install two wires (47 and 46) on solenoid stud (48) with new locknut (45).
4. Install two cables (41 and 40) and two wires (43 and 42) on solenoid stud (44) with nut (39).
5. Install three cables (37, 36, and 35) on starter ground stud (38) with nut (34).



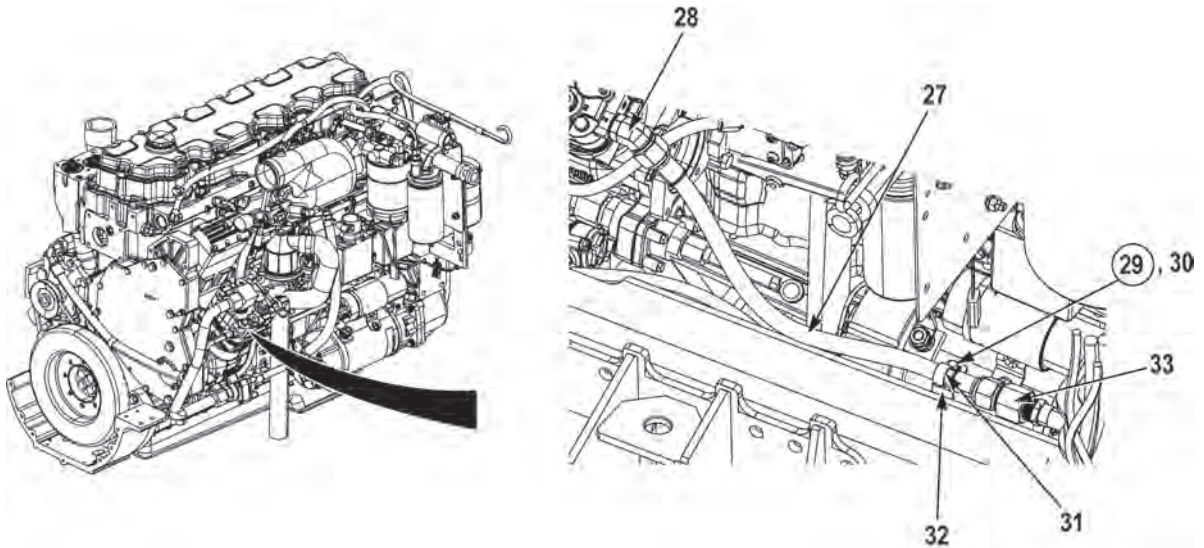

### NOTE

Perform Steps (6) through (11) for vehicles with 45 degree compressor outlet fitting.

6. Install hose (27) on fitting (33).
7. Install hose (27) on standoff bracket (32) with cushion clip (31), screw (30), and locknut (29).
8. Install hose (27) on fitting (28).

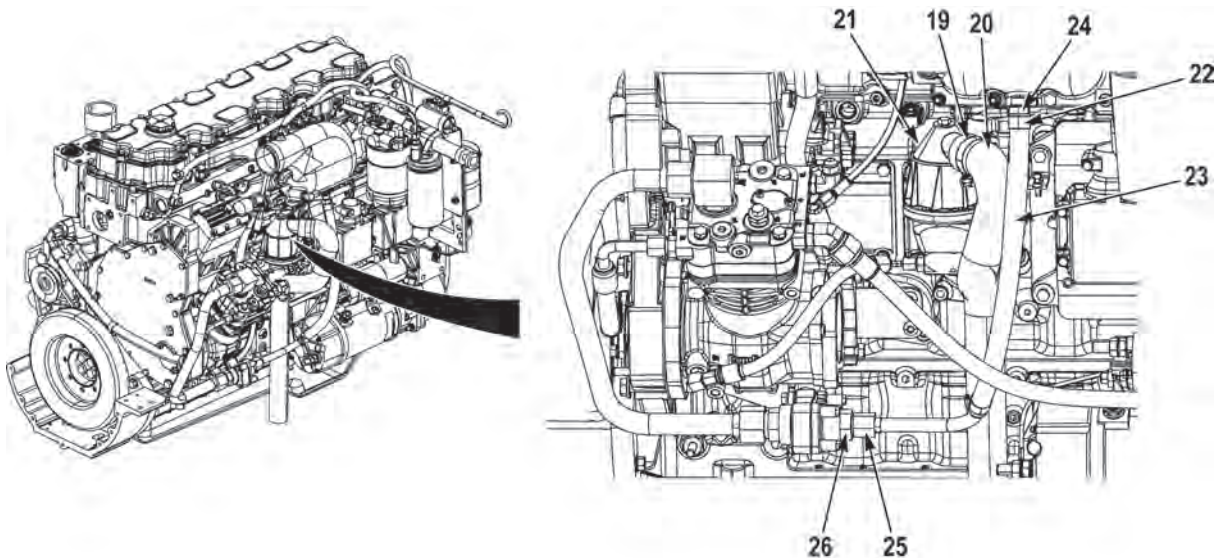

9. Install tube (25) on fitting (26).
10. Install hose (23) on fitting (24) with clamp (22).
11. Install hose (20) on breather assembly (21) with clamp (19).

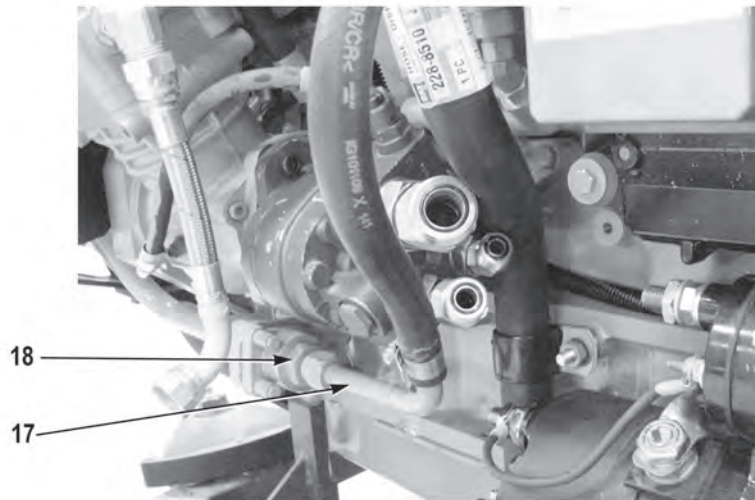

### NOTE

Perform Steps (12) through (18) for vehicles with 90 degree compressor outlet fitting.

12. Install tube (17) on fitting (18).

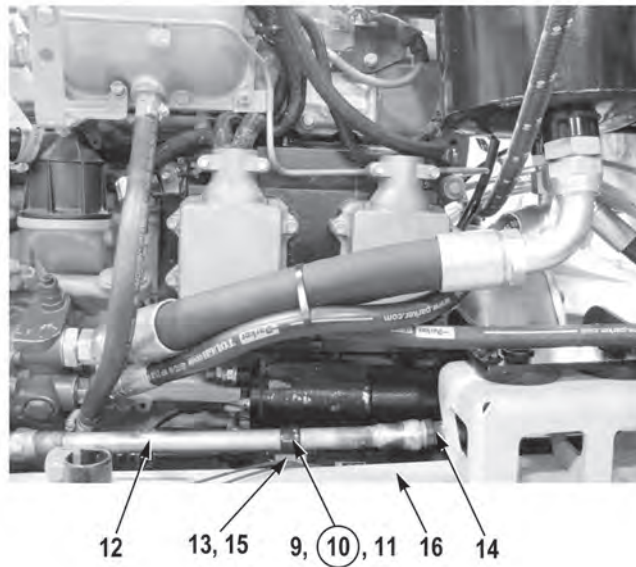

13. Install bracket (13) on frame rail (16) with screw (15).

**WARNING**

Adhesives, solvents, and sealing compounds can burn easily, can give off harmful vapors, and are harmful to skin and clothing. To avoid injury or death, keep away from open fire and use in well-ventilated area. If adhesive, solvent, or sealing compound gets on skin or clothing, wash immediately with soap and water. Failure to comply may result in injury or death to personnel.

14. Apply sealing compound, Loctite 592, to threads of tube (14) and install tube (12) on tube (14).
15. Install cushion clip (11) and tube (12) on bracket (13) with screw (9) and new locknut (10).

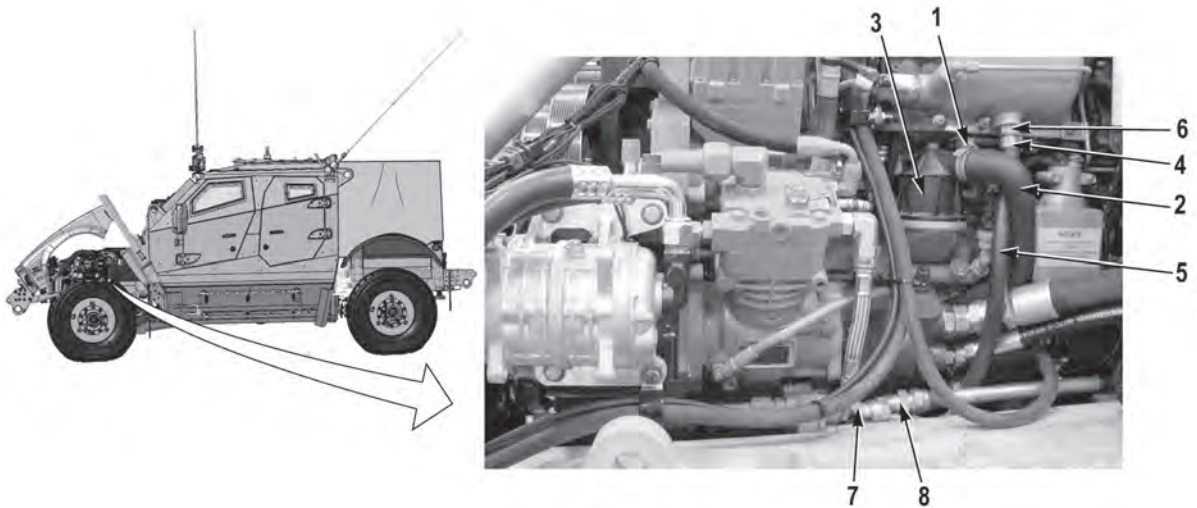

16. Install hose (7) on fitting (8).
17. Install hose (5) on fitting (6) with clamp (4).
18. Install hose (2) on breather assembly (3) with clamp (1).
19. Perform all Follow-On Maintenance tasks.

**END OF TASK**

**END OF WORK PACKAGE**





---

**STOPLIGHT SWITCH REPLACEMENT**

---

**Preconditions**

Park vehicle  
 Engine OFF  
 Wheels chocked  
 Air system drained  
 Batteries disconnected (M1240/M1240A1)  
 (WP 0186)  
 Batteries disconnected (M1245) (WP 0187)

**Tools and Special Tools**

Tool Kit, General Mechanic's: Automotive

**Materials/Parts**

Compound, Sealing, Loctite 592  
 Tags, Identification  
 Ties, Cable

**Follow-On Maintenance**

Connect batteries (M1240/M1240A1) (WP 0186)  
 Connect batteries (M1245) (WP 0187)  
 Remove and stow wheel chocks

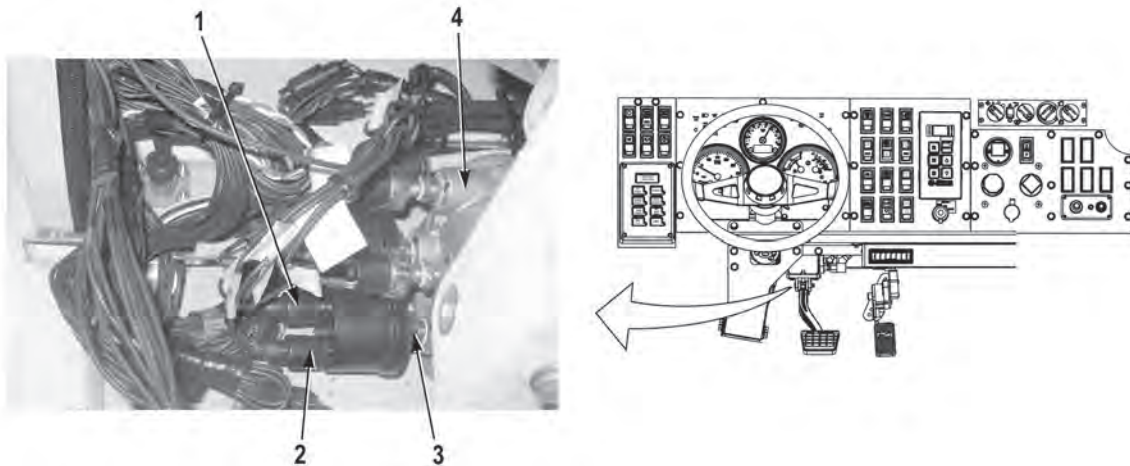
**REMOVAL****WARNING**

**Ensure air system is drained prior to working on air system components. Failure to comply may result in injury or death to personnel.**

**NOTE**

- Tag and mark wires prior to removal to ensure proper installation.
  - Remove cable ties as required.
  - Both stoplight switches are removed the same way.
1. Disconnect connectors (1 and 2) from stoplight switch (3).
  2. Remove stoplight switch (3) from treadle valve (4).

**END OF TASK**

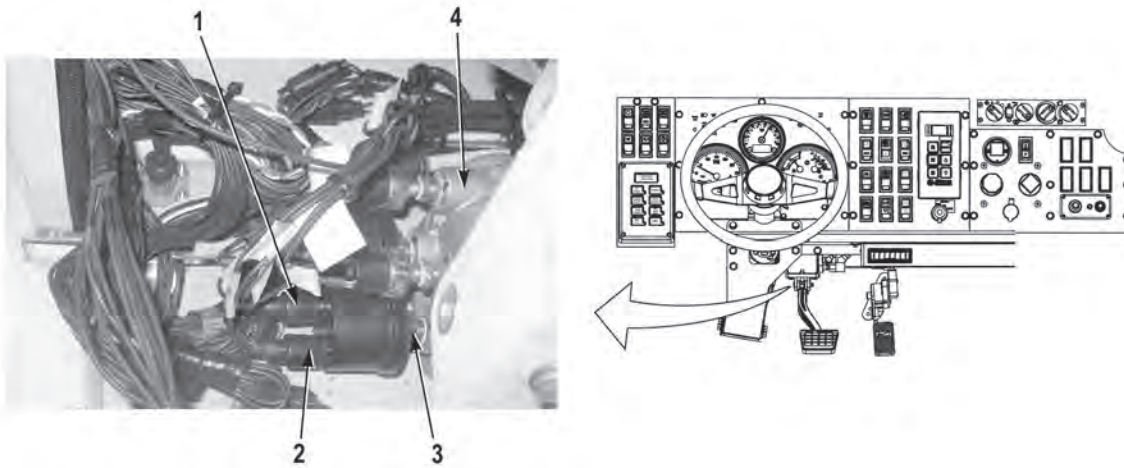
**INSTALLATION****WARNING**

Adhesives, solvents, and sealing compounds can burn easily, can give off harmful vapors, and are harmful to skin and clothing. To avoid injury or death, keep away from open fire and use in well-ventilated area. If adhesive, solvent, or sealing compound gets on skin or clothing, wash immediately with soap and water. Failure to comply may result in injury or death to personnel.

**NOTE**

- Install cable ties as required.
  - Both stoplight switches are installed the same way.
1. Apply sealing compound, Loctite 592, to stoplight switch (3).
  2. Install stoplight switch (3) on treadle valve (4).

**NOTE**

Install wires as noted prior to removal.

3. Connect connectors (1 and 2) on stoplight switch (3).
4. Perform all Follow-On Maintenance tasks.

**END OF TASK**

**END OF WORK PACKAGE**

---

**TRANSMISSION CONTROL MODULE (TCM) REPLACEMENT**

---

**Preconditions**

- Park vehicle
- Engine OFF
- Wheels chocked
- Batteries disconnected (M1240/M1240A1)  
(WP 0186)
- Batteries disconnected (M1245) (WP 0187)

**Tools and Special Tools**

- Tool Kit, General Mechanic's: Automotive

**Materials/Parts**

- Locknut (2) (Item 7)
- Tags, Identification

**Follow-On Maintenance**

- Connect batteries (M1240/M1240A1) (WP 0186)
- Connect batteries (M1245) (WP 0187)
- Remove and stow wheel chocks

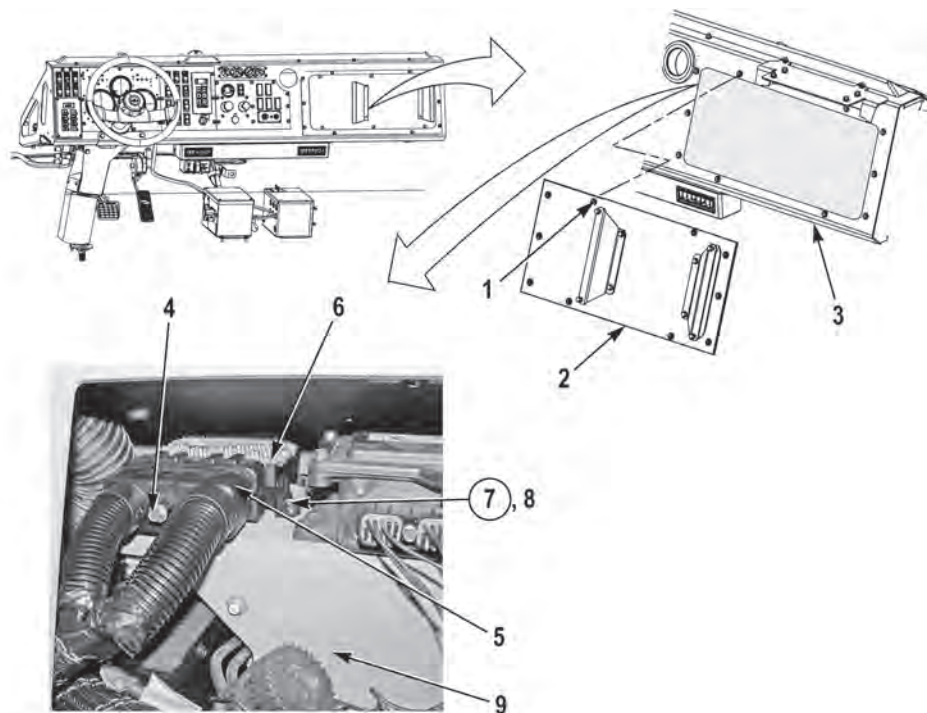
**REMOVAL**

1. Remove ten screws (1) and dash circuit breaker cover (2) from dash (3).

**NOTE**

Tag and mark connector prior to removal to ensure proper installation.

2. Loosen screw (4) and disconnect connector (5) from transmission control module (6).
3. Remove two locknuts (7), screws (8), and transmission control module (6) from dash panel compartment tray (9). Discard locknuts (7).

**END OF TASK**

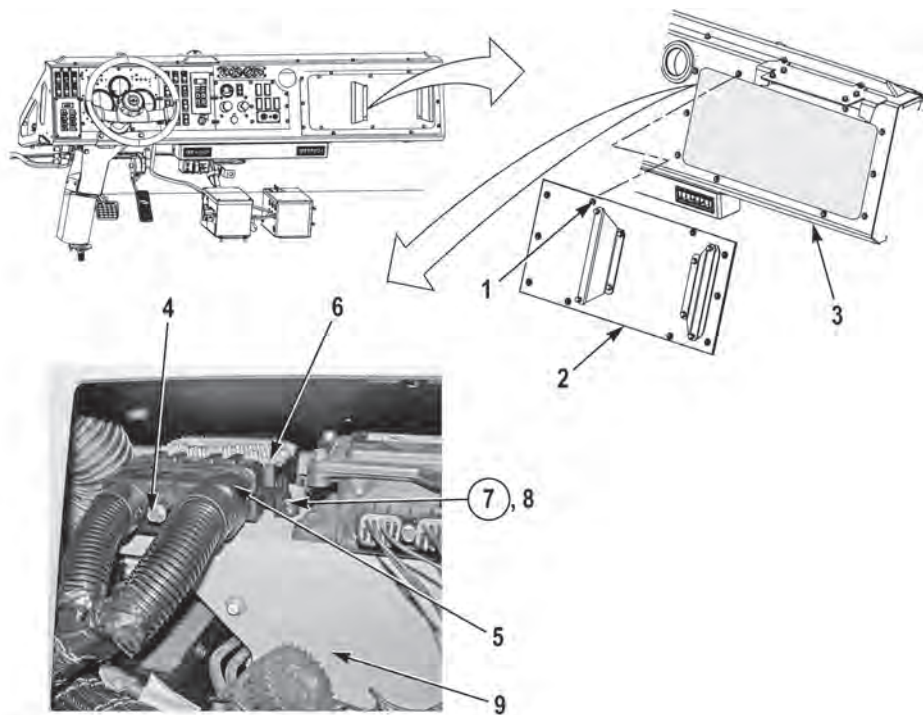
**INSTALLATION**

1. Install transmission control module (6) on dash panel compartment tray (9) with two screws (8) and new locknuts (7).
2. Connect connector (5) to transmission control module (6) and tighten screw (4).
3. Install dash circuit breaker cover (2) on dash (3) with ten screws (1).
4. Perform all Follow-On Maintenance tasks.

**END OF TASK****END OF WORK PACKAGE**

---

**VOLTAGE REGULATOR REPLACEMENT**

---

**Preconditions**

Park vehicle  
Engine OFF  
Wheels chocked  
Hood opened and secured  
Batteries disconnected (M1240/M1240A1)  
(WP 0186)  
Batteries disconnected (M1245) (WP 0187)

**Tools and Special Tools**

Lifting Device  
Tool Kit, General Mechanic's: Automotive

**Materials/Parts**

Locknut (Item 4)  
Compound, Sealing, Novagard 200-257  
Lubricant, Connector, Nyogel 760G  
Tags, Identification  
Ties, Cable

**Follow-On Maintenance**

Connect batteries (M1240/M1240A1) (WP 0186)  
Connect batteries (M1245) (WP 0187)  
Close and secure hood  
Remove and stow wheel chocks

---

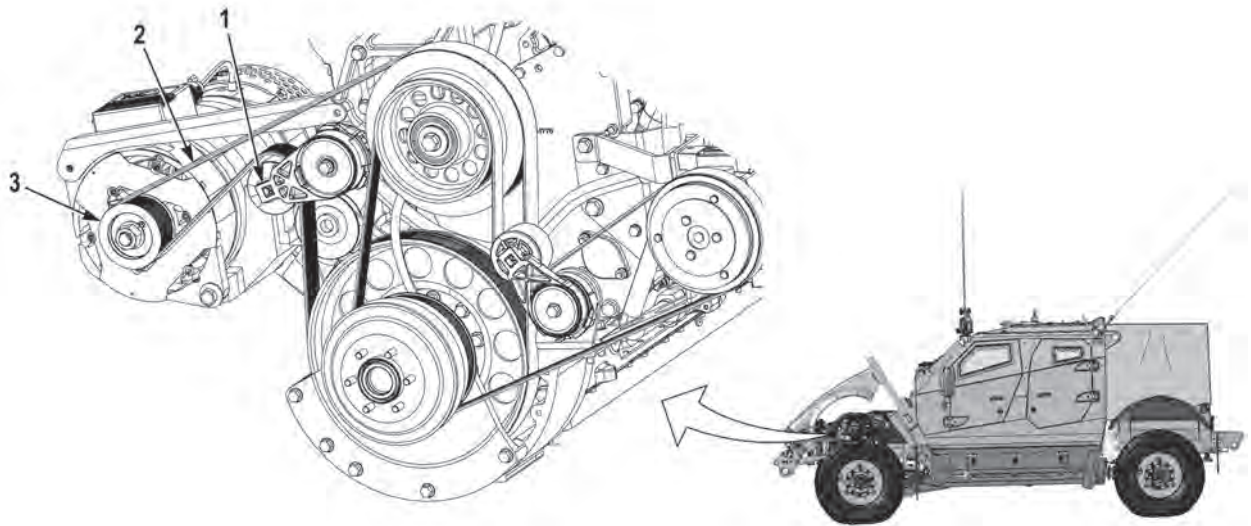
**REMOVAL**

1. Release tension of belt tensioner idler pulley (1) and remove belt (2) from tensioner idler pulley (1) and alternator pulley (3).



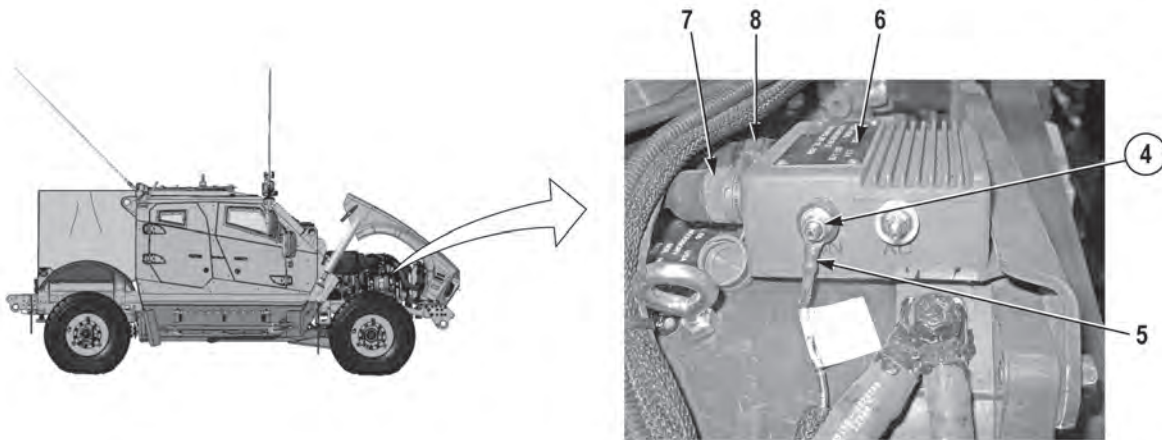

### **WARNING**

Engine components become hot during normal operation. Allow engine to cool completely prior to performing this task. Failure to comply may result in injury to personnel.

### **NOTE**

- Tag and mark wires and connectors prior to removal to ensure proper installation.
  - Remove cable ties as required.
2. Remove locknut (4) and wire (5) from voltage regulator (6). Discard locknut (4).
  3. Disconnect two connectors (7 and 8) from voltage regulator (6).

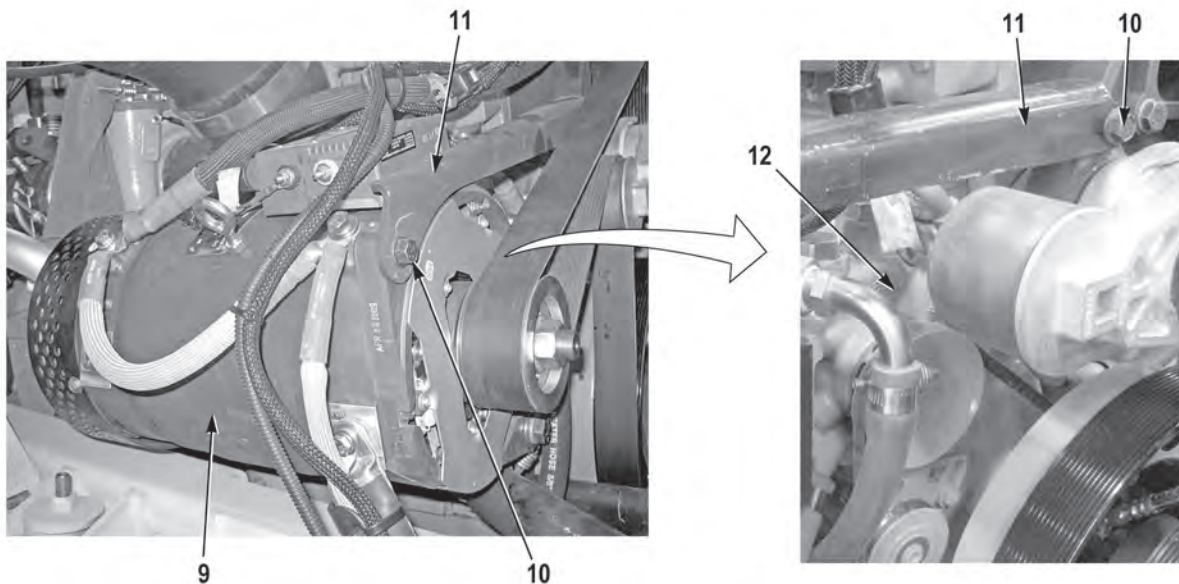



**WARNING**

**Alternator weighs 115 lbs (52 kg). Support alternator with lifting device prior to removing support bracket. Failure to comply may result in injury to personnel.**

4. Support alternator (9) with lifting device and remove two screws (10), and support bracket (11) from engine (12) and alternator (9).

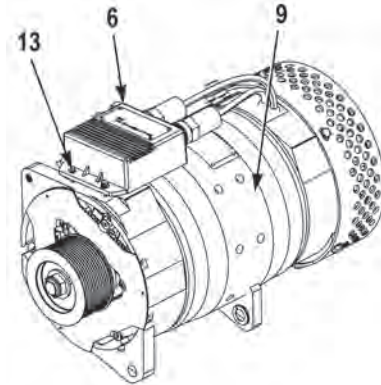

5. Remove three screws (13) and voltage regulator (6) from alternator (9).

**END OF TASK****INSTALLATION**

1. Install voltage regulator (6) on alternator (9) with three screws (13).
2. Install support bracket (11) on engine (12) and alternator (9) with two screws (10).
3. Remove lifting device from alternator (9).

**WARNING**

**Connector lubricant is harmful to skin. Prolonged or repeated contact with skin or contact with eyes may cause irritation. If eyes are contacted, rinse thoroughly and contact physician if irritation persists. If skin is contacted, wash thoroughly with soap and water. Failure to comply may result in injury or death to personnel.**

4. Apply connector lubricant, Nyogel 760G, to connectors (7 and 8) and connect two connectors (7 and 8) to voltage regulator (6).

**NOTE**

Install cable ties as required.

5. Install wire (5) on voltage regulator (6) with new locknut (4).

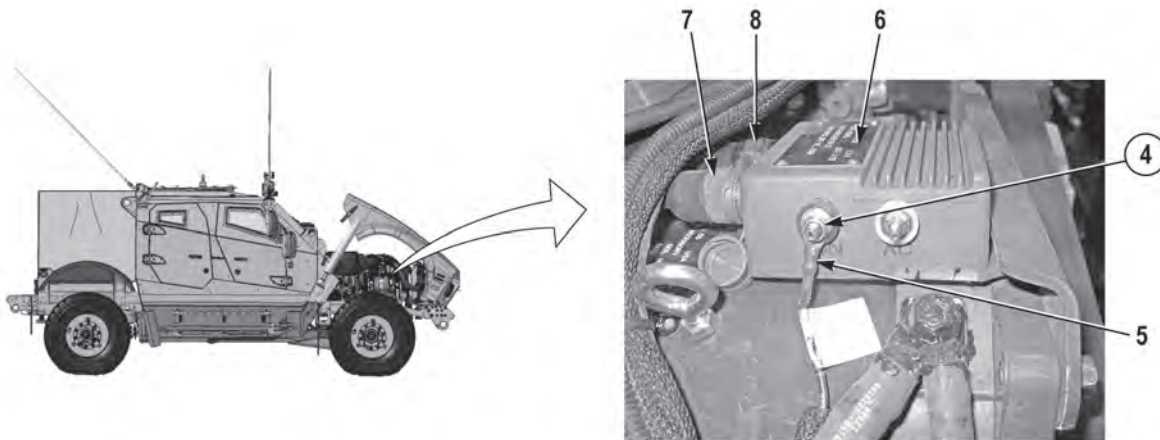

### **WARNING**

Adhesives, solvents, and sealing compounds can burn easily, can give off harmful vapors, and are harmful to skin and clothing. To avoid injury or death, keep away from open fire and use in well-ventilated area. If adhesive, solvent, or sealing compound gets on skin or clothing, wash immediately with soap and water. Failure to comply may result in injury or death to personnel.

6. Apply sealing compound, Novagard 200-257, to locknut (4) and wire (5).

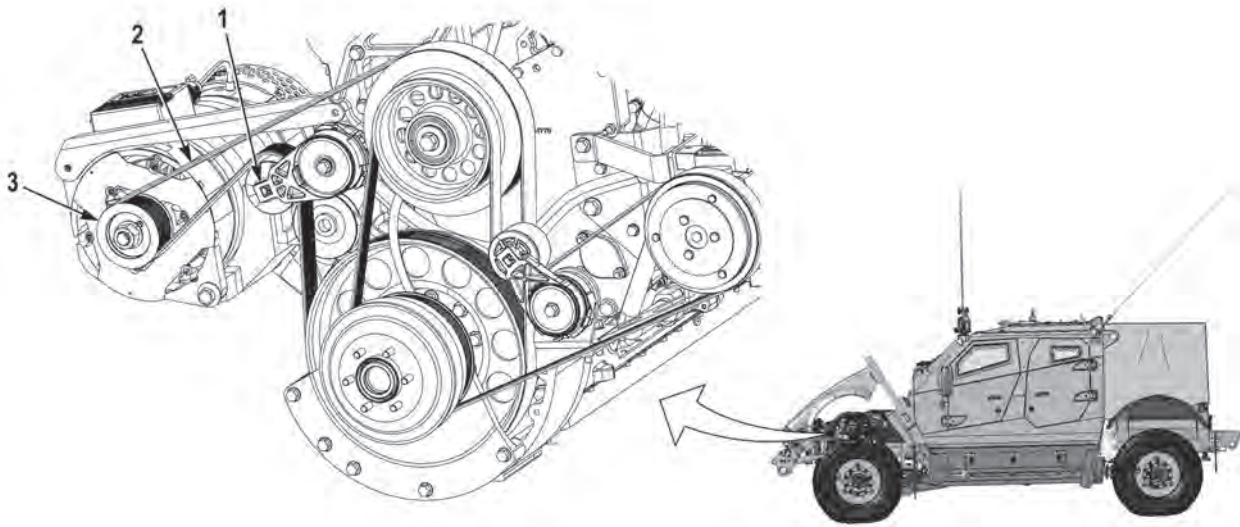

7. Release tension of belt tensioner idler pulley (1) and install belt (2) on alternator pulley (3) and belt tensioner idler pulley (1).
8. Perform all Follow-On Maintenance tasks.

**END OF TASK**

**END OF WORK PACKAGE**

---

**WIRING HARNESS REPAIR**

---

**Preconditions**

Park vehicle  
Engine OFF  
Wheels chocked  
Batteries disconnected (M1240/M1240A1)  
(WP 0186)  
Batteries disconnected (M1245) (WP 0187)

**Tools and Special Tools**

Crimping Tool, Terminal, Hand  
(NSN 5120-01-481-2194)  
Crimping Tool, Terminal, Hand  
(NSN 5120-01-374-8936)  
Crimping Tool, Terminal (NSN 5120-01-355-0844)  
Extractor, Electrical Connector, Plug  
Tool Kit, General Mechanic's: Automotive  
Remover, Electrical Connector  
(NSN 5120-01-394-0296)  
Remover, Electrical Connector  
(NSN 5120-01-374-8969)  
Remover, Electrical Connector  
(NSN 5120-01-015-2154)  
Remover, Electrical Connector  
(NSN 5120-01-353-2534)

**Materials/Parts**

Locknut (4) (Item 1)  
Coating, Conformal, Sealant, 75297  
Compound, Anti-Corrosion Spray, 2233850  
Heatshrink, Sealed  
Lubricant, Connector, Nyogel 760G  
Tags, Identification  
Ties, Cable

**Follow-On Maintenance**

Connect batteries (M1240/M1240A1) (WP 0186)  
Connect batteries (M1245) (WP 0187)  
Remove and stow wheel chocks

## TYPE 1 CONNECTOR REPAIR

### CAUTION

Terminals come in different styles and sizes. To prevent damage, be sure to use only the exact replacements. Do not attempt to modify terminal to fit. Failure to comply may result in damage to equipment.

### NOTE

- All type 1 connectors are repaired the same way. Number of wires in connection may vary.
- Repeat procedure as necessary.
- Tag and mark wires prior to disassembly to ensure proper assembly.
- Remove cable ties and loosen cushion clips as required.

### 1. Disassembly

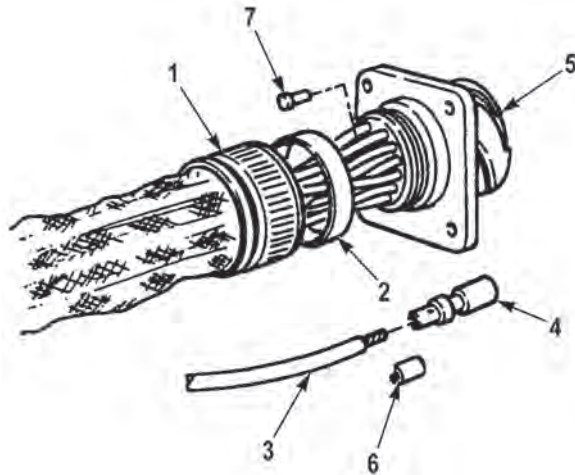

- Unscrew cover (1).
- Slide plastic sleeve (2) back.
- Remove wire (3) and terminal (4) from connector (5).

### NOTE

Cut as close to damaged terminal as possible.

- Cut off terminal (4) at end of wire (3). Remove insulation (6) 0.25 in. (0.64 cm) from end of wire (3). Discard terminal (4).

---

## 2. Assembly

- a. Install terminal (4) on wire (3) and crimp in place.
- b. Install terminal (4) on connector (5).
- c. Install sealing plugs (7) in unused holes.
- d. Slide plastic sleeve (2) against connector (5).
- e. Install cover (1) on connector (5).

### **WARNING**

**Anti-corrosion compound is toxic. Use only in well-ventilated area. Use NIOSH/MSHA-approved respirator with dual organic vapor/mist and particulate cartridge. Do not get in eyes; wear chemical safety goggles and full face shield when using. Avoid contact with skin and wear rubber or plastic, solvent-resistant gloves. In case of contact, remove contaminated clothing and immediately wash area with soap and water. If eyes are contacted, flush eyes with large amounts of water for at least 15 minutes and get immediate medical attention. If swallowed, do not induce vomiting; contact a physician immediately. Failure to comply may result in injury or death to personnel.**

- f. Apply anti-corrosion spray, 2233850, to cushion clips that were removed and installed.
- g. Perform all Follow-On Maintenance tasks.

## END OF TASK

## TYPE 2 CONNECTOR REPAIR

### **CAUTION**

**Terminals come in different styles and sizes. To prevent damage, be sure to use only the exact replacements. Do not attempt to modify terminal to fit. Failure to comply may result in damage to equipment.**

### **NOTE**

- All type 2 connectors are repaired the same way. Number of wires in connection may vary.
- Repeat procedure as necessary.
- Tag and mark wires prior to disassembly to ensure proper assembly.
- Remove cable ties and loosen cushion clips as required.

## 1. Disassembly

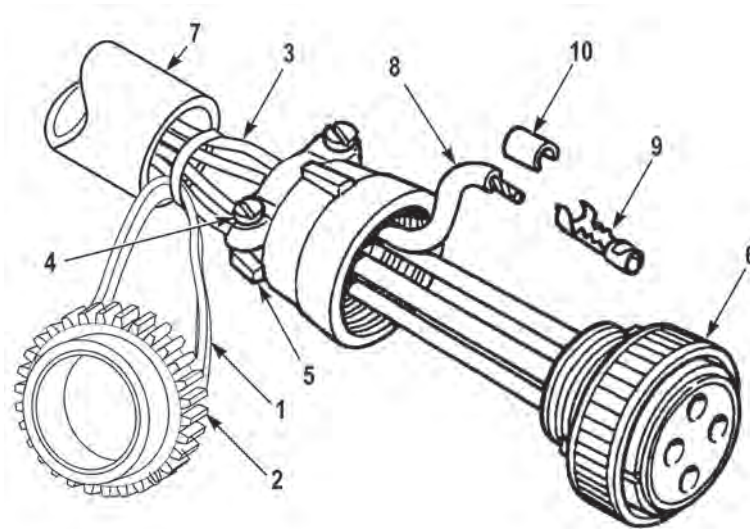

### NOTE

- Some type 2 connectors have a dust cover attached to wire harness.
  - Perform Step (a) only if connecting wire harness has an attached dust cover.
- a. Remove dust cover retaining strap (1) and dust cover (2) from wire harness (3).
  - b. Remove two screws (4) and cable clamp (5) from connector (6).
  - c. Remove heat shrink (7).
  - d. Remove wire (8) and terminal (9) from connector (6).

### NOTE

Cut as close to damaged terminal as possible.

- e. Cut off terminal (9) at end of wire (8). Remove insulation (10) 0.25 in. (0.64 cm) from end of wire (8). Discard terminal (9).

## 2. Assembly

- a. Install terminal (9) on wire (8) and crimp in place.
- b. Install terminal (9) in connector (6).
- c. Install cable clamp (5) on connector (6) with two screws (4).
- d. Install heat shrink (7) around wire harness (3).

---

**NOTE**

- Some type 2 connectors have a dust cover attached to wire harness.
  - Perform Step (e) only if wire harness previously had an attached dust cover.
- e. Install dust cover (2) with retaining strap (1) on wire harness (3).

**WARNING**

**Anti-corrosion compound is toxic. Use only in well-ventilated area. Use NIOSH/MSHA-approved respirator with dual organic vapor/mist and particulate cartridge. Do not get in eyes; wear chemical safety goggles and full face shield when using. Avoid contact with skin and wear rubber or plastic, solvent-resistant gloves. In case of contact, remove contaminated clothing and immediately wash area with soap and water. If eyes are contacted, flush eyes with large amounts of water for at least 15 minutes and get immediate medical attention. If swallowed, do not induce vomiting; contact a physician immediately. Failure to comply may result in injury or death to personnel.**

- f. Apply anti-corrosion spray, 2233850, to cushion clips that were removed and installed.
- g. Perform all Follow-On Maintenance tasks.

**END OF TASK**



## TYPE 3 CONNECTOR REPAIR

### 1. Disassembly

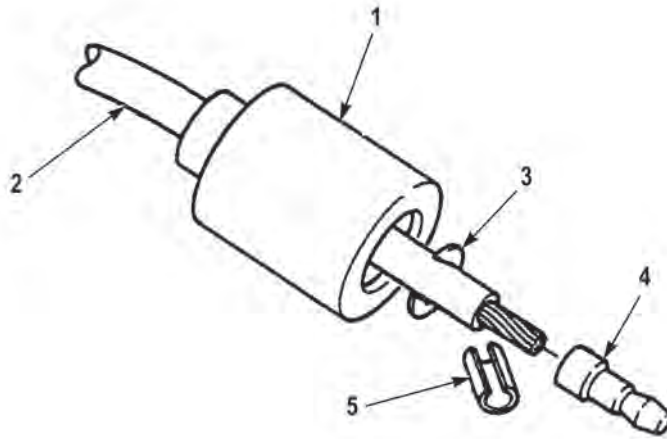

### NOTE

- Tag and mark wires prior to disassembly to ensure proper assembly.
- Repeat procedure as necessary.
- Remove cable ties and loosen cushion clips as required.

- a. Slide outer shell (1) back on wire (2).
- b. Remove C-washer (3) from wire (2).
- c. Cut terminal (4) from wire (2).
- d. Trim end of wire (2) as needed.
- e. Remove 0.375 in. (1.0 cm) of insulation (5) from end of wire (2).

### 2. Assembly

- a. Install terminal (4) on wire (2).
- b. Install C-washer (3) on wire (2) just below terminal (4).
- c. Slide outer shell (1) over C-washer (3) and terminal (4).
- d. Be sure no bare wire (2) is visible outside of outer shell (1).

**WARNING**

Anti-corrosion compound is toxic. Use only in well-ventilated area. Use NIOSH/MSHA-approved respirator with dual organic vapor/mist and particulate cartridge. Do not get in eyes; wear chemical safety goggles and full face shield when using. Avoid contact with skin and wear rubber or plastic, solvent-resistant gloves. In case of contact, remove contaminated clothing and immediately wash area with soap and water. If eyes are contacted, flush eyes with large amounts of water for at least 15 minutes and get immediate medical attention. If swallowed, do not induce vomiting; contact a physician immediately. Failure to comply may result in injury or death to personnel.

- e. Apply anti-corrosion spray, 2233850, to cushion clips that were removed and installed.
- f. Perform all Follow-On Maintenance tasks.

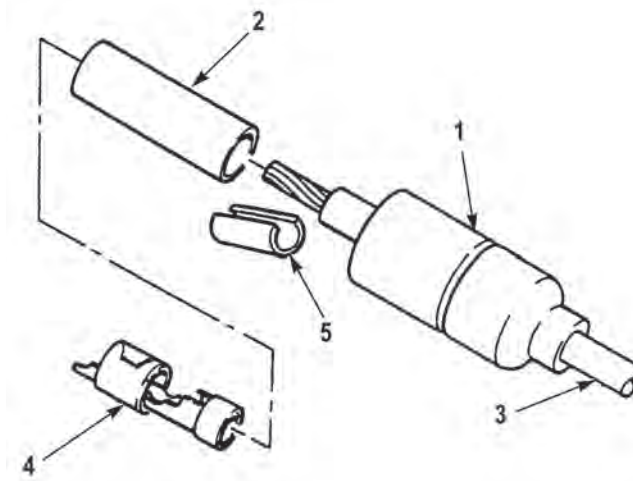
**END OF TASK****TYPE 4 CONNECTOR REPAIR****1. Disassembly****NOTE**

- Tag and mark wires prior to disassembly to ensure proper assembly.
  - Repeat procedure as necessary.
  - Remove cable ties and loosen cushion clips as required.
- a. Slide outer shell (1) and sleeve (2) back on wire (3).
  - b. Remove contact (4) from wire (3).
  - c. Trim end of wire (3) as needed to make an undamaged end.
  - d. Remove 0.25 in. (0.64 cm) of insulation (5) from end of wire (3).

## Assembly

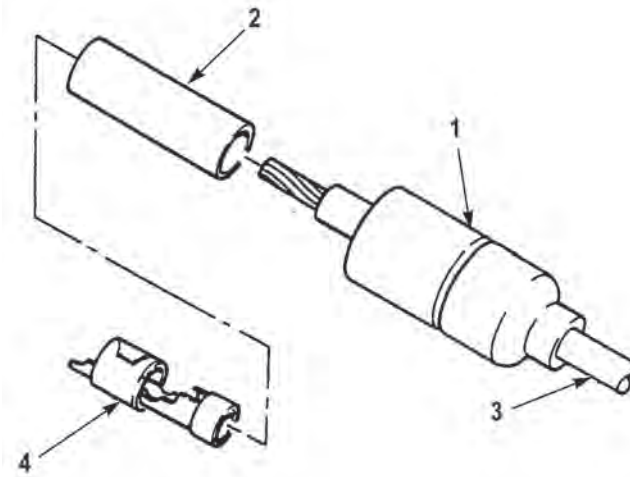

- a. Install sleeve (2) over end of wire (3).
- b. Install contact (4) over end of wire (3).
- c. Crimp contact (4) securely in place.
- d. Slide outer shell (1) over sleeve (2) and contact (4).
- e. Be sure no bare wire (3) shows outside of outer shell (1).

### **WARNING**

**Anti-corrosion compound is toxic. Use only in well-ventilated area. Use NIOSH/MSHA-approved respirator with dual organic vapor/mist and particulate cartridge. Do not get in eyes; wear chemical safety goggles and full face shield when using. Avoid contact with skin and wear rubber or plastic, solvent-resistant gloves. In case of contact, remove contaminated clothing and immediately wash area with soap and water. If eyes are contacted, flush eyes with large amounts of water for at least 15 minutes and get immediate medical attention. If swallowed, do not induce vomiting; contact a physician immediately. Failure to comply may result in injury or death to personnel.**

- f. Apply anti-corrosion spray, 2233850, to cushion clips that were removed and installed.
- g. Perform all Follow-On Maintenance tasks.

**END OF TASK**

---

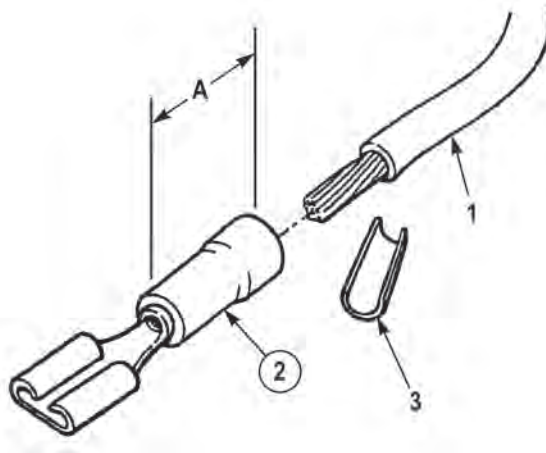
**TYPE 5 CONNECTOR REPAIR****1. Disassembly****CAUTION**

Terminals come in different styles and sizes. To prevent damage, be sure to use only the exact replacements. Do not attempt to modify terminal to fit. Failure to comply may result in damage to equipment.

**NOTE**

- Tag and mark wires prior to disassembly to ensure proper assembly.
  - Repeat procedure as necessary.
  - Remove cable ties and loosen cushion clips as required.
  - Cut as close to damaged terminal as possible.
- a. Cut wire (1) at end of terminal (2). Discard terminal (2).
  - b. Remove insulation (3) from wire (1) equal to dimension (A).

**2. Assembly****NOTE**

All strands of wire must be inside terminal when installing wire.

- a. Install terminal (2) on wire (1) and crimp securely.
- b. Perform all Follow-On Maintenance tasks.

**END OF TASK**

### 3. TYPE 6 CONNECTOR REPAIR

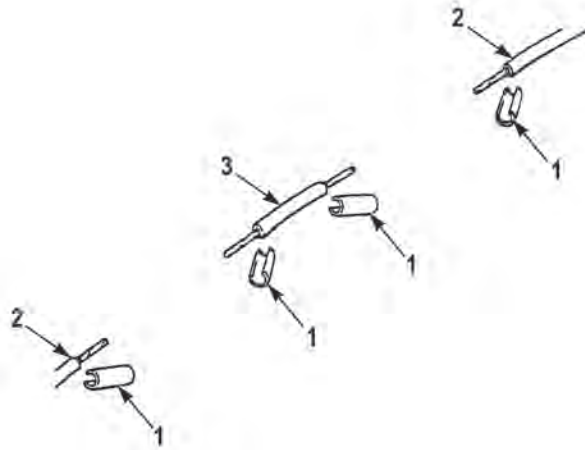

### 4. Disassembly

#### NOTE

- Tag and mark wires prior to disassembly to ensure proper assembly.
  - Repeat procedure as necessary.
  - Remove cable ties and loosen cushion clips as required.
  - Replace original butt connectors with solder and heat shrink as described in Type 6 connector repair.
  - Perform Step (a) if repairing broken wire.
- a. Remove 0.75 in. (1.9 cm) of insulation (1) from both ends of wire (2).

#### NOTE

Perform Steps (b) through (d) if section of wire is being replaced.

- b. Measure distance of wire (2) being replaced.
- c. Cut section of new wire (3) 2 in. (5.08 cm) longer than distance of wire (2) being replaced.
- d. Remove 0.75 in. (1.9 cm) of insulation (1) from both ends of new wire (3).

## 5. Assembly

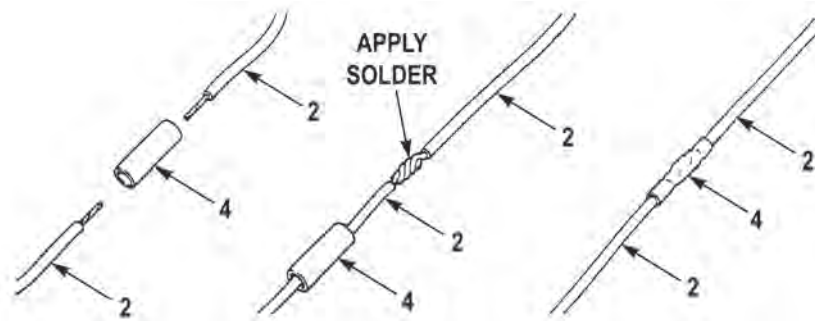

### NOTE

Perform Steps (a) through (d) if repairing broken wire.

- a. Slide 3 in. (7.62 cm) piece of heat shrink tubing (4) over one end of wire (2).

### WARNING

**Allow solder to cool before handling. Failure to comply may result in injury to personnel.**

### NOTE

Solder must flow evenly onto both ends of wire.

- b. Twist two ends of wire (2) together and solder.
- c. Slide heat shrink tubing (4) over solder joint.

### WARNING

- **Never use open flame to apply heat to heat shrink tubing. Heat shrinking tubing may catch fire using open flame. Failure to comply may result in injury to personnel.**
- **Allow heat shrink tubing to cool before handling. Failure to comply may result in injury to personnel.**

### CAUTION

**Do not apply excessive heat to heat shrink tubing. Excessive heat may cause heat shrink tubing to split or melt. Failure to comply may result in damage to equipment.**

### NOTE

- Center solder joint in heat shrink tubing.
  - Allow heat shrink tubing to shrink until tight on solder joint and insulation of wire.
- d. Apply heat to heat shrink tubing (4) covering two wires (2).

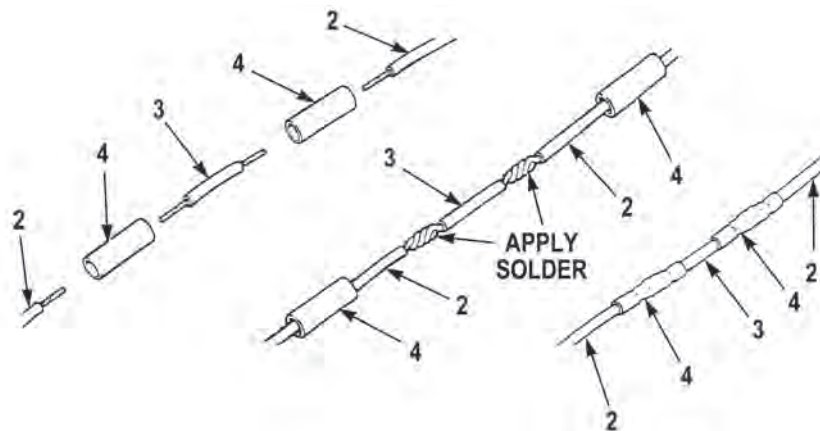

### NOTE

Perform Steps (e) through (h) if section of wire is being replaced.

- e. Slide two 3 in. (7.62 cm) pieces of heat shrink tubing (4) over both ends of wire (2).

### WARNING

**Allow solder to cool before handling. Failure to comply may result in injury to personnel.**

### NOTE

Solder must flow evenly onto both ends of wire.

- f. Twist two ends of wire (2) and new wire (3) together and solder.  
g. Slide heat shrink tubing (4) over solder joints.

### WARNING

- **Never use open flame to apply heat to heat shrink tubing. Heat shrinking tubing may catch fire using open flame. Failure to comply may result in injury to personnel.**
- **Allow heat shrink tubing to cool before handling. Failure to comply may result in injury to personnel.**

### CAUTION

**Do not apply excessive heat to heat shrink tubing. Excessive heat may cause heat shrink tubing to split or melt. Failure to comply may result in damage to equipment.**

### NOTE

- Center solder joints in heat shrink tubing.
  - Allow heat shrink tubing to shrink until tight on solder joint and insulation of wire.
- h. Apply heat to heat shrink tubing (4) covering solder joints, two wires (2 and 3).  
i. Perform all Follow-On Maintenance tasks.

**END OF TASK**



## TYPE 7 CONNECTOR REPAIR

### 1. Removal

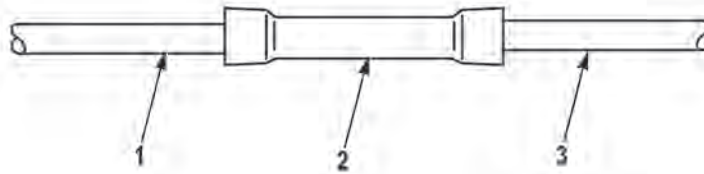

### CAUTION

Butt splice connector sizes vary by wire diameter. To ensure secure repair, use only butt splice connector size specified for the wire being repaired. Do not modify butt splice connector to fit. Failure to comply may result in damage to equipment.

### NOTE

- Tag and mark wires prior to repair to ensure proper assembly.
- Remove cable ties and loosen cushion clips as required.
- If replacing butt splice connector, cut wire as close to butt connector as possible.
  - a. Cut wire (1) as close to butt splice connector (2) as possible.
  - b. Cut wire (3) as close to butt splice connector (2) as possible.
  - c. Discard butt splice connector (2).

### 2. Installation

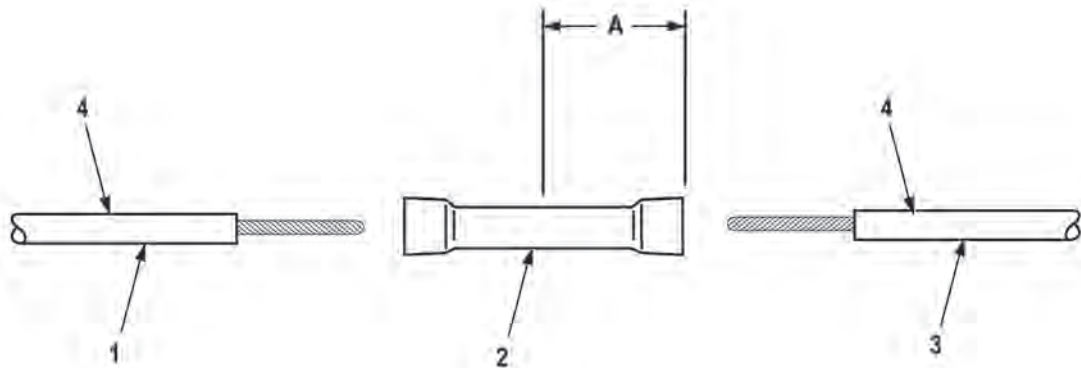

- a. Remove insulation (4) from two wires (1 and 3) equal to dimension (A).
- b. Install wire (1) in butt splice connector (2) until end of wire (1) is at middle of butt splice connector (2).
- c. Install wire (3) in opposite end of butt splice connector (2) until wire (3) touches wire (1).
- d. Crimp butt splice connector (2) on two wires (1 and 3) securely.
- e. Perform all Follow-On Maintenance tasks.

**END OF TASK**

## GROUP I TERMINAL REPAIR

### 1. Disassembly

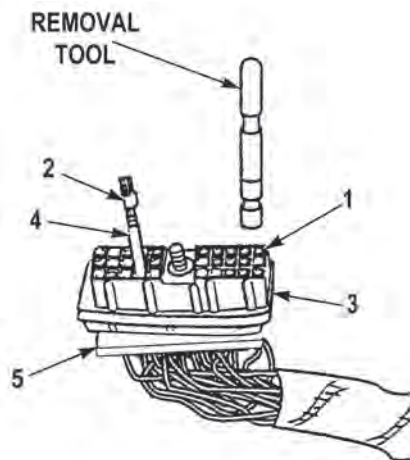

### **WARNING**

**Tip of removal tool is very sharp. Use caution when using tool. Failure to comply may result in injury to personnel.**

### **NOTE**

- Tag and mark wires prior to disassembly to ensure proper assembly.
  - Locking tab on terminal mates with molded tab in plastic connector to retain cable assembly.
  - Remove cable ties and loosen cushion clips as required.
  - All Group I connectors are repaired the same way. Number of wires in connector may vary.
  - Repeat procedure as necessary.
- a. Insert tip of removal tool between locking tab (1) of terminal (2) and wall of connector (3).
  - b. Release locking tab (1) from connector (3).
  - c. Push terminal (2) through front of connector (3).

### **NOTE**

- Perform Step (d) only if old terminal is still attached to wire.
  - Make cut directly behind damaged terminal.
- d. Cut and remove terminal (2) from wire (4). Discard terminal (2).
  - e. Remove wire (4) from connector (3) and seal (5).

## 2. Assembly

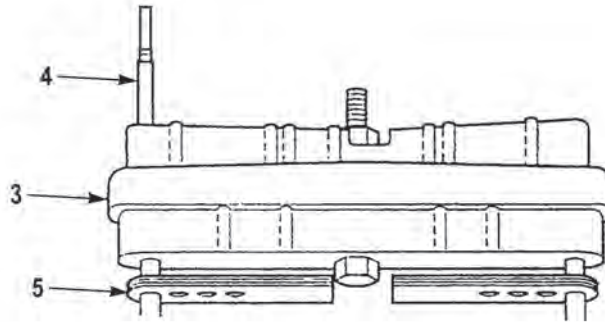

- a. Push wire (4) through seal (5) and connector (3) cavity.

### **CAUTION**

**Strip wire after placing it through seal to prevent damage to individual wire strands.  
Failure to comply may result in damage to equipment.**

- b. Strip end of wire (4) using crimp tool, leaving 0.25 in. (0.64 cm) of bare wire.

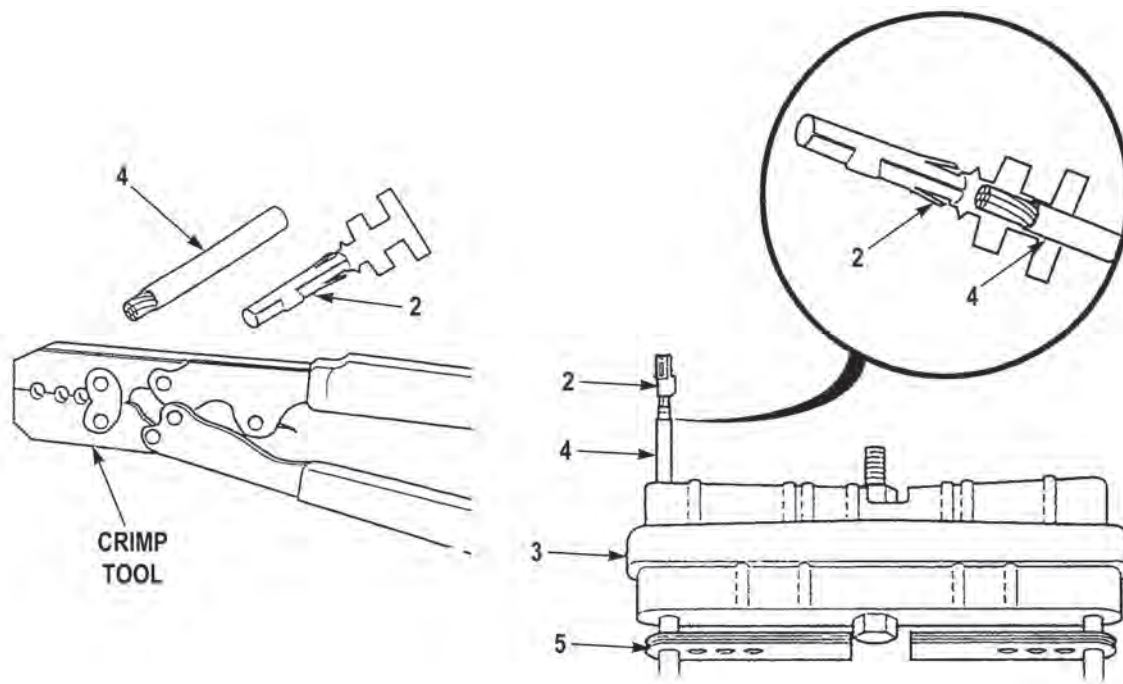
**NOTE**

When installing terminal, be sure terminal wings point to the upper jaw of crimping tool.

- c. Push terminal holder open and insert terminal (2) until attaching portion of terminal rests on anvil.

**NOTE**

Wire should be positioned so larger wings of terminal will crimp around insulation and smaller wings will crimp around exposed bare wire.

- d. Position wire (4) on terminal (2).  
 e. Press handle(s) of crimp tool together until ratchet releases and crimp is complete.

**NOTE**

Locking tab should be positioned toward notch in connector cavity when properly installed.

- f. Pull wire (4) and terminal (2) back through connector (3) until seated.  
 g. Seat seal (5) into connector (3).

**WARNING**

Anti-corrosion compound is toxic. Use only in well-ventilated area. Use NIOSH/MSHA-approved respirator with dual organic vapor/mist and particulate cartridge. Do not get in eyes; wear chemical safety goggles and full face shield when using. Avoid contact with skin and wear rubber or plastic, solvent-resistant gloves. In case of contact, remove contaminated clothing and immediately wash area with soap and water. If eyes are contacted, flush eyes with large amounts of water for at least 15 minutes and get immediate medical attention. If swallowed, do not induce vomiting; contact a physician immediately. Failure to comply may result in injury or death to personnel.

- h. Apply anti-corrosion spray, 2233850, to cushion clips that were removed and installed.

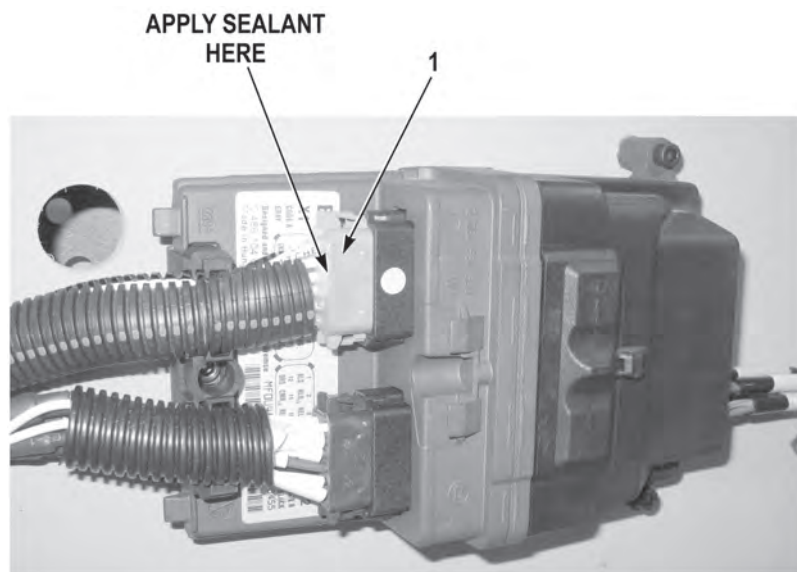
**WARNING**

Adhesives, solvents, and sealing compounds can burn easily, can give off harmful vapors, and are harmful to skin and clothing. To avoid injury or death, keep away from open fire and use in well-ventilated area. If adhesive, solvent, or sealing compound gets on skin or clothing, wash immediately with soap and water. Failure to comply may result in injury or death to personnel.

**NOTE**

Perform Step (i) if repairing ABS power interface wire harness.

- i. Apply sealant, Conformal Coating 75297, to rear seal and wires on ABS power interface wire harness connector behind locking tab (1).
- j. Perform all Follow-On Maintenance tasks.

**END OF TASK**

---

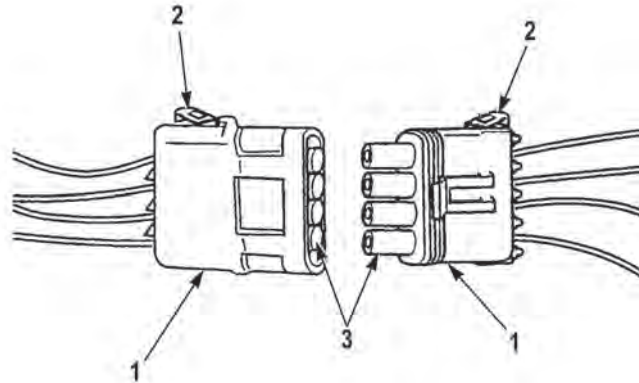
**GROUP II TERMINAL REPAIR****1. Disassembly****NOTE**

- Tag and mark wires prior to disassembly to ensure proper assembly.
  - Connector is removed by gently prying up on clip and pulling on connector.
  - Remove cable ties and loosen cushion clips as required.
  - All Group II connectors are repaired the same way. Number of wires in connector may vary.
  - Both halves of connector are repaired the same way.
- a. Disconnect connector (1).
  - b. Unlatch and open two secondary locks (2) on connector (1).

**WARNING**

**Tip of removal tool is very sharp. Use caution when using tool. Failure to comply may result in injury to personnel.**

- c. Insert removal tool into cavity (3) on connector (1) until seated.

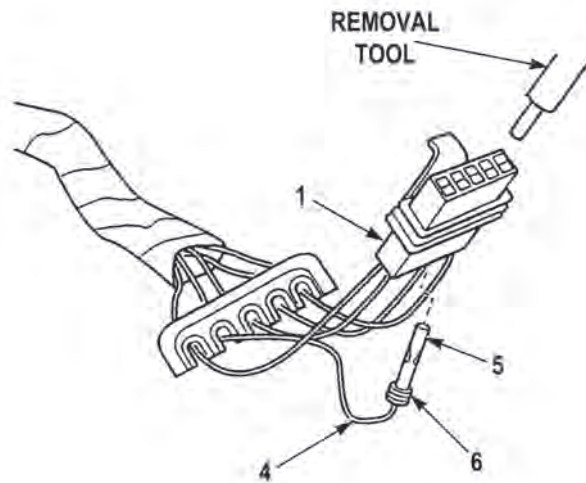

- d. Pull wire (4) back through connector (1) and remove tool.

#### NOTE

- Perform Step (e) only if old terminal is still attached to wire.
  - Make cut directly behind damaged terminal.
- e. Cut terminal (5) and wire seal (6) from wire (4).
- f. Discard terminal (5) and wire seal (6).



## 2. Assembly

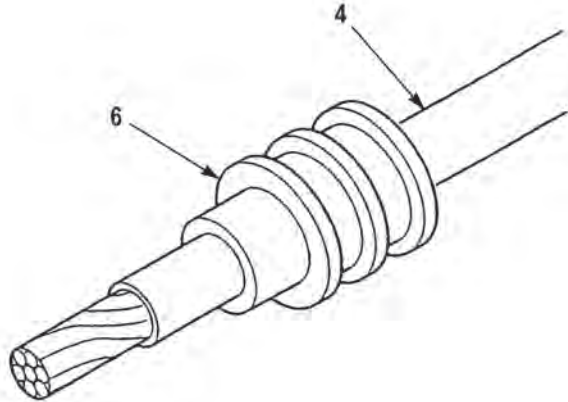

- a. Insert 1 in. (2.5 cm) of wire (4) through new wire seal (6).

### **CAUTION**

**Strip wire after placing it through seal to prevent damage to individual wire strands. Failure to comply may result in damage to equipment.**

- b. Strip end of wire (4) leaving 0.25 in. (0.64 cm) of bare wire.

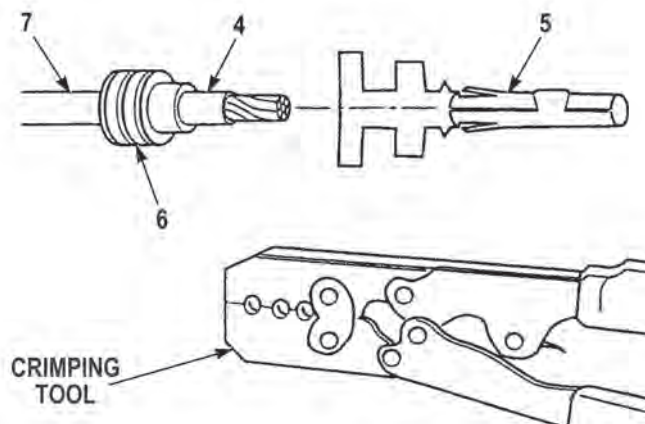

- c. Insert new terminal (5) in locating hole of crimp tool using proper hole according to the gauge of wire (4).  
 d. Slide wire seal (6) down to end of insulation (7) on wire (4).

### **NOTE**

Wire and seal should be positioned so larger wings of terminal will crimp around seal and smaller wings will crimp around exposed bare wire.

- e. Position wire (4) on terminal (5).  
 f. Press handle(s) of crimping tool together until ratchet releases and crimp is complete.

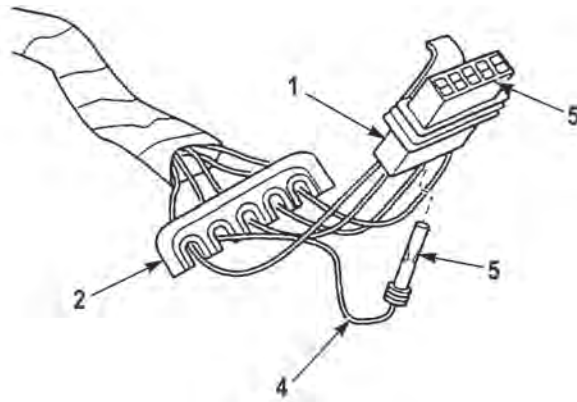

- g. Push new terminal (5) and wire (4) through connector (1) until seated.
- h. Close two secondary locks (2) on connector (1).

### **WARNING**

**Connector lubricant is harmful to skin. Prolonged or repeated contact with skin or contact with eyes may cause irritation. If eyes are contacted, rinse thoroughly and contact physician if irritation persists. If skin is contacted, wash thoroughly with soap and water. Failure to comply may result in injury or death to personnel.**

- i. Apply connector lubricant, Nyogel 760G, to connector (1).

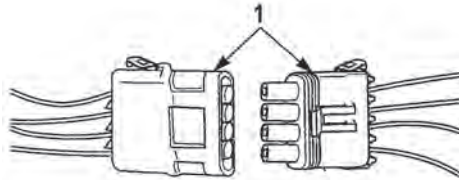

- j. Connect connector (1).

### **WARNING**

**Anti-corrosion compound is toxic. Use only in well-ventilated area. Use NIOSH/MSHA-approved respirator with dual organic vapor/mist and particulate cartridge. Do not get in eyes; wear chemical safety goggles and full face shield when using. Avoid contact with skin and wear rubber or plastic, solvent-resistant gloves. In case of contact, remove contaminated clothing and immediately wash area with soap and water. If eyes are contacted, flush eyes with large amounts of water for at least 15 minutes and get immediate medical attention. If swallowed, do not induce vomiting; contact a physician immediately. Failure to comply may result in injury or death to personnel.**

- k. Apply anti-corrosion spray, 2233850, to cushion clips that were removed and installed.
- l. Perform all Follow-On Maintenance tasks.

**END OF TASK**

## GROUP III TERMINAL REPAIR

### 1. Disassembly

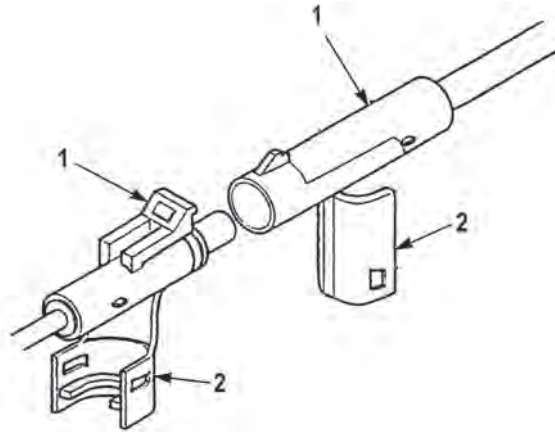

### NOTE

- Tag and mark all wires prior to disassembly to ensure proper assembly.
  - Connector is removed by gently prying up on clip and pulling on connector.
  - Remove cable ties and loosen cushion clips as required.
  - All group III connectors are repaired the same way. Number of wires in connector may vary.
  - Both halves of connector are repaired the same way.
- a. Disconnect connector (1).
  - b. Unlatch and remove two secondary locks (2) on connector (1).

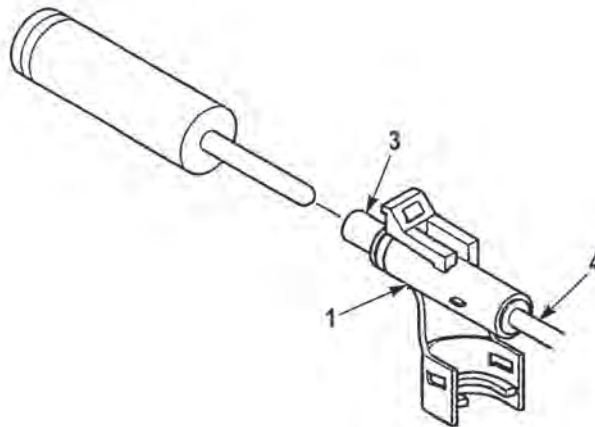

- c. Insert removal tool into terminal connector cavity (3) until seated.
- d. Pull wire (4) back through connector (1) and removal tool.

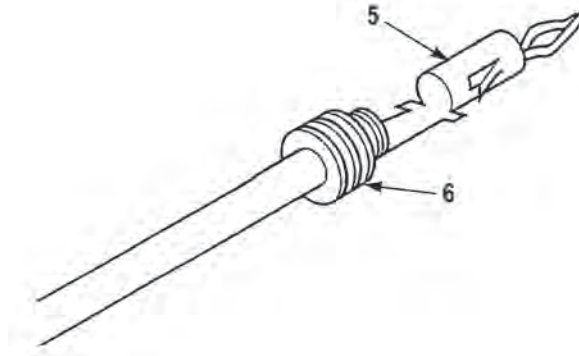

### NOTE

- Perform Step (e) only if old terminal is still attached to wire.
- Make cut directly behind damaged terminal.

e. Cut off terminal (5) and wire seal (6). Discard terminal and seal.

### 2. Assembly

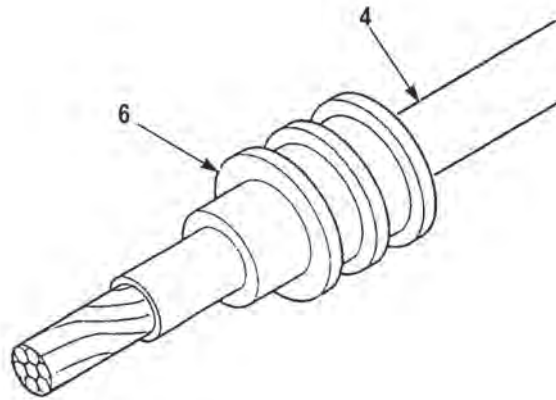

a. Insert 1 in. (2.5 cm) of wire (4) through new wire seal (6).

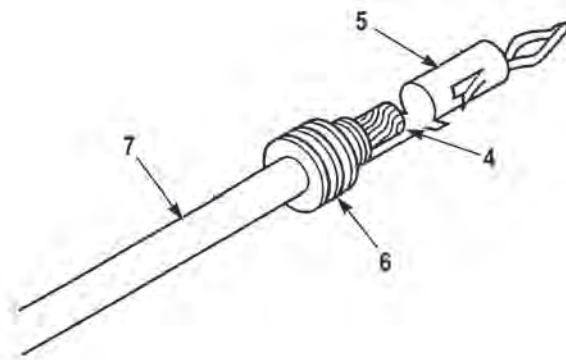

### **CAUTION**

**Strip wire after placing it through seal to prevent damage to individual wire strands.  
Failure to comply may result in damage to equipment.**

- b. Strip end of wire (4) leaving 0.25 in. (0.64 cm) of bare wire.
- c. Insert new terminal (5) in locating hole of crimp tool using the proper hole according to gauge of wire (4).
- d. Slide wire seal (6) down to end of insulation (7) on wire (4).

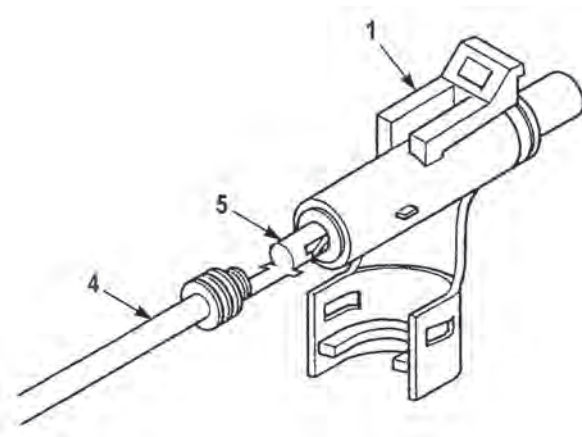

### **NOTE**

Wire and seal should be positioned so larger wings of terminal will crimp around insulation and smaller wings will crimp around exposed bare wire.

- e. Position wire (4) on terminal (5).
- f. Press handles of crimp tool together until ratchet releases and crimp is complete.
- g. Push new terminal (5) and wire (4) through connector (1) until seated.

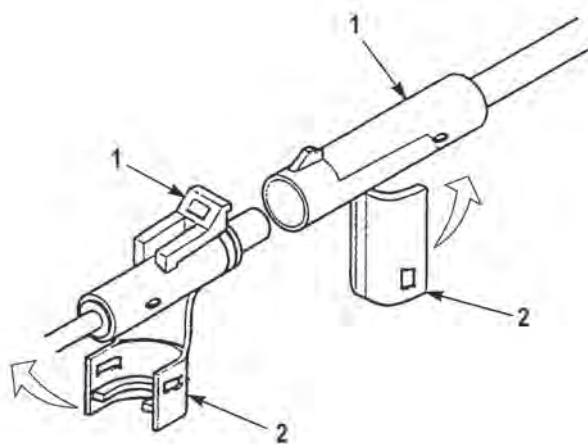

- h. Install two secondary locks (2) on connector (1).
- i. Connect connector (1).

### **WARNING**

**Anti-corrosion compound is toxic. Use only in well-ventilated area. Use NIOSH/MSHA-approved respirator with dual organic vapor/mist and particulate cartridge. Do not get in eyes; wear chemical safety goggles and full face shield when using. Avoid contact with skin and wear rubber or plastic, solvent-resistant gloves. In case of contact, remove contaminated clothing and immediately wash area with soap and water. If eyes are contacted, flush eyes with large amounts of water for at least 15 minutes and get immediate medical attention. If swallowed, do not induce vomiting; contact a physician immediately. Failure to comply may result in injury or death to personnel.**

- j. Apply anti-corrosion spray, 2233850, to cushion clips that were removed and installed.
- k. Perform all Follow-On Maintenance tasks.

### **END OF TASK**

### **12-PIN ELECTRICAL CONNECTOR REPAIR**

#### **1. Disassembly**

### **NOTE**

- Tag and mark wires prior to removal to ensure proper installation.
- Remove cable ties and loosen cushion clips as required.

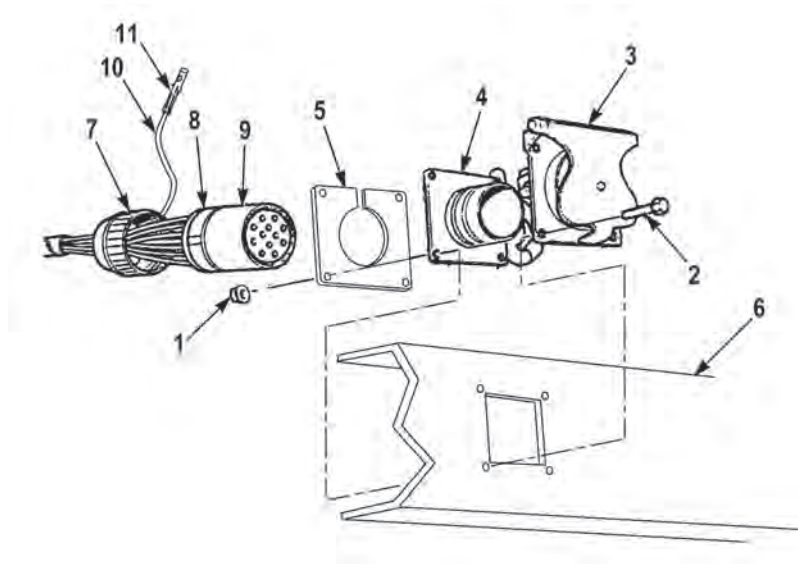

- a. Remove four locknuts (1), screws (2), spring cover (3), and electrical connector housing (4) from plate (5) and front bumper (6). Discard locknuts (1).
- b. Remove collar (7) and collar boot (8) from electrical connector housing (4).
- c. Remove electrical connector (9) from electrical connector housing (4).
- d. Using removal tool, remove wires (10) with pins (11) from electrical connector (9).

## 2. Assembly

- a. Install pins (11) and wires (10) in electrical connector (9).

### NOTE

Align tab with keyway.

- b. Install electrical connector (9) in plate (5) and electrical connector housing (4).
- c. Install collar boot (8) and collar (7) on electrical connector housing (4).

### NOTE

Electrical connector housing must be positioned on front bumper with keyway facing up.

- d. Align four holes in electrical connector housing (4) with holes in front bumper (6).
- e. Install plate (5), electrical connector housing (4) and spring cover (3) on front bumper (6) with four screws (2) and new locknuts (1).



---

**WARNING**

Anti-corrosion compound is toxic. Use only in well-ventilated area. Use NIOSH/MSHA-approved respirator with dual organic vapor/mist and particulate cartridge. Do not get in eyes; wear chemical safety goggles and full face shield when using. Avoid contact with skin and wear rubber or plastic, solvent-resistant gloves. In case of contact, remove contaminated clothing and immediately wash area with soap and water. If eyes are contacted, flush eyes with large amounts of water for at least 15 minutes and get immediate medical attention. If swallowed, do not induce vomiting; contact a physician immediately. Failure to comply may result in injury or death to personnel.

- f. Apply anti-corrosion spray, 2233850, to cushion clips that were removed and installed.
- g. Perform all Follow-On Maintenance tasks.

**END OF TASK****TERMINAL CONNECTOR REPAIR****1. Disassembly****CAUTION**

Terminals come in different styles and sizes. To prevent damage, be sure to use only the exact replacements. Do not attempt to modify terminal to fit. Failure to comply may result in damage to equipment.

**NOTE**

- Tag and mark wires prior to disassembly to ensure proper assembly.
- Repeat procedure as necessary.
- Remove cable ties and loosen cushion clips as required.
- All terminal connectors are repaired the same way. Number of wires in connection may vary.

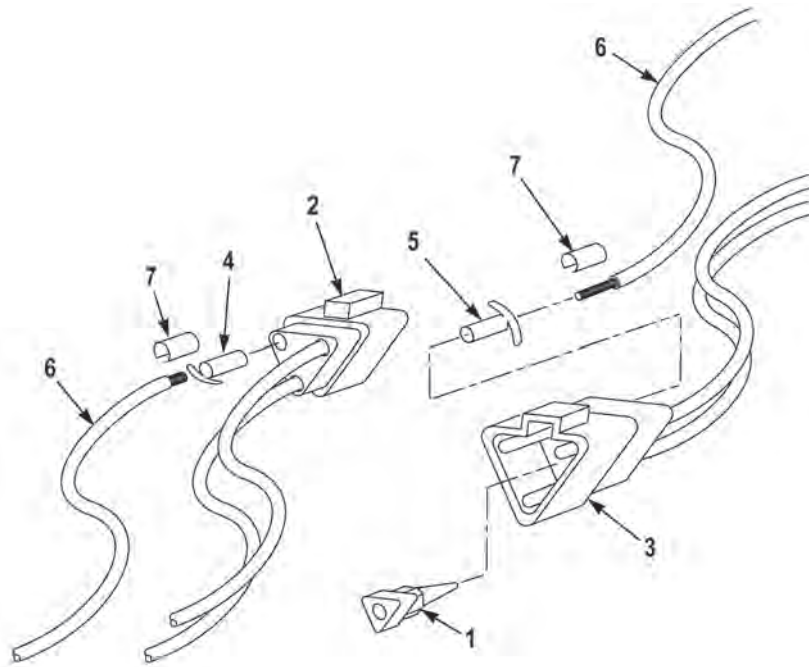

- a. Remove wedge (1) from connector (2 or 3).
- b. Depress locking finger, holding terminal (4 or 5) in connector (2 or 3) and remove wire (6).

### NOTE

Cut as close to damaged wire as possible.

- c. Cut off terminal (4 or 5) at end of wire (6). Remove insulation (7) 0.25 in. (0.64 cm) from end of wire. Discard terminal (4).

## 2. Assembly

- a. Install terminal (4 or 5), as needed, on end of wire (6).

### NOTE

Terminal clicks when seated in connector.

- b. Install terminal (4 or 5) with wire (6) in connector (2 or 3) until seated.
- c. Pull gently on wire (6) to confirm terminal seat in connector (2 or 3).

### NOTE

Install and seat all terminals in connector before installing wedge.

- d. Install wedge (1) in connector (2 or 3).

**WARNING**

Anti-corrosion compound is toxic. Use only in well-ventilated area. Use NIOSH/MSHA-approved respirator with dual organic vapor/mist and particulate cartridge. Do not get in eyes; wear chemical safety goggles and full face shield when using. Avoid contact with skin and wear rubber or plastic, solvent-resistant gloves. In case of contact, remove contaminated clothing and immediately wash area with soap and water. If eyes are contacted, flush eyes with large amounts of water for at least 15 minutes and get immediate medical attention. If swallowed, do not induce vomiting; contact a physician immediately. Failure to comply may result in injury or death to personnel.

- e. Apply anti-corrosion spray, 2233850, to cushion clips that were removed and installed.
- f. Perform all Follow-On Maintenance tasks.

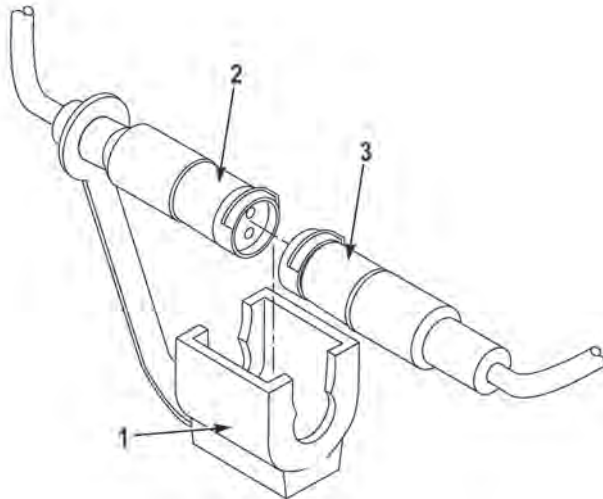
**END OF TASK****TWO-PIN AND FOUR-PIN CONNECTOR REPAIR****1. Disassembly****NOTE**

- Remove cable ties and loosen cushion clips as required.
  - Two-pin and four-pin connectors are repaired the same way. Two-pin connector shown.
- a. Remove connector lock (1) from connector (2) and connector (3).

**NOTE**

Tag and mark connectors prior to removal to ensure proper installation.

- b. Disconnect connector (2) from connector (3).

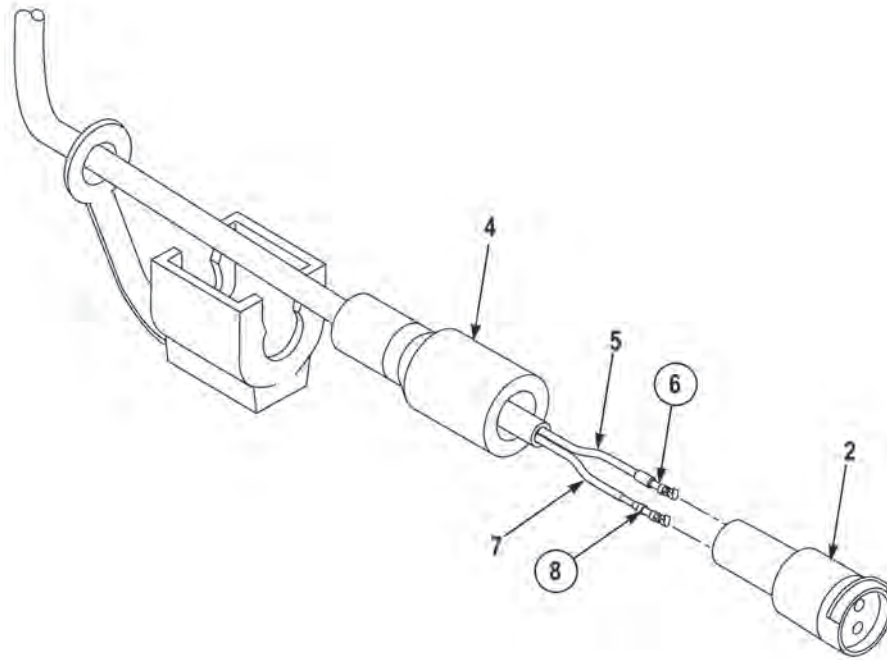

- c. Remove sleeve (4) from connector (2).

**NOTE**

Tag and mark wires prior to removal to ensure proper installation.

- d. Remove wire (5) and terminal (6) from connector (2).
- e. Remove wire (7) and terminal (8) from connector (2).

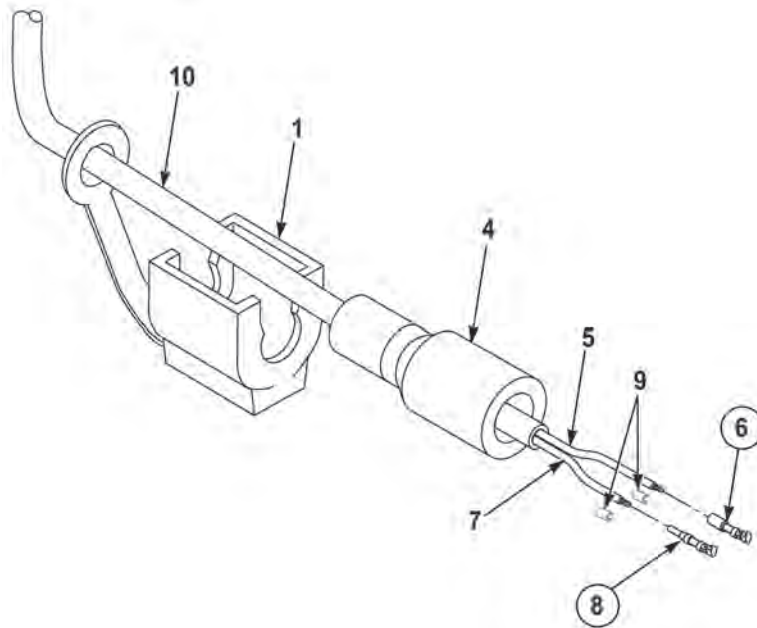

### NOTE

Cut as close to damaged terminals as possible.

- f. Cut off two terminals (6 and 8) at end of wires (5 and 7). Discard terminals (6 and 8).
- g. Remove insulation (9) 0.25 in. (0.64 cm) from end of two wires (5 and 7).
- h. Remove sleeve (4) and connector lock (1) from cable (10).

### 2. Assembly

- a. Install connector lock (1) and sleeve (4) on cable (10).
- b. Install two terminals (6 and 8) on wires (5 and 7) and crimp in place.

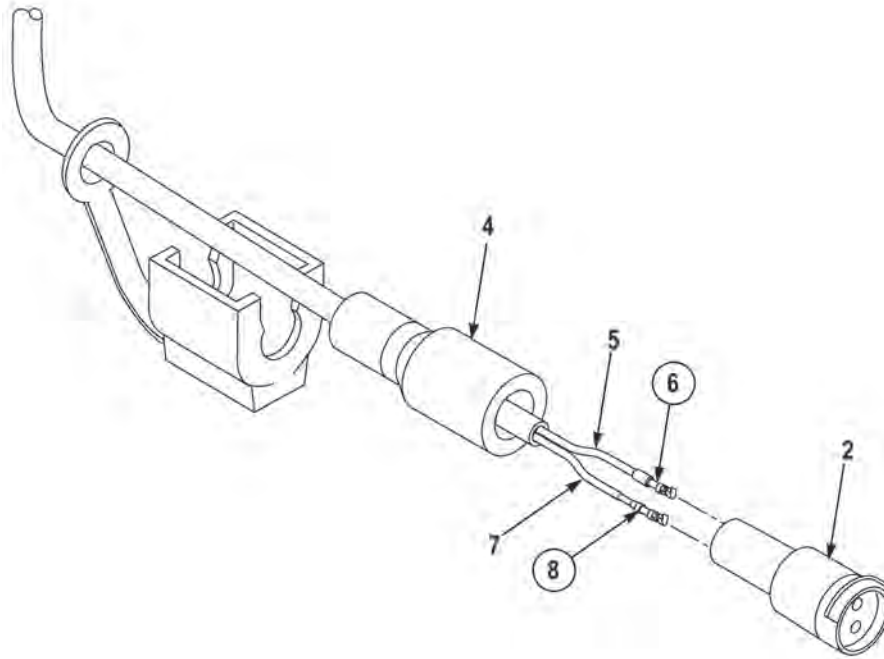

- c. Install terminal (8) and wire (7) in connector (2).
- d. Install terminal (6) and wire (5) in connector (2).
- e. Install sleeve (4) on connector (2).

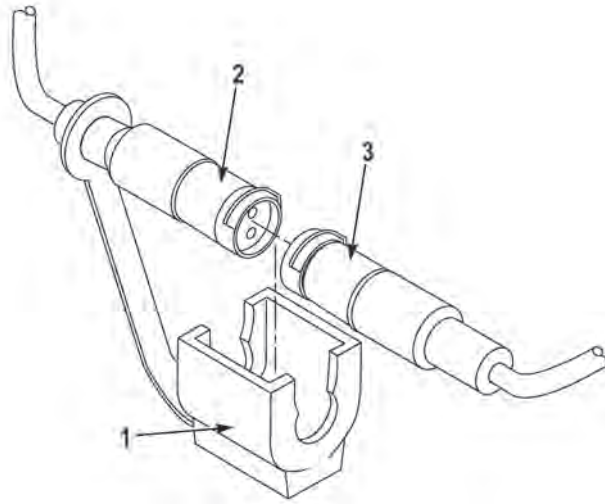
**WARNING**

Connector lubricant is harmful to skin. Prolonged or repeated contact with skin or contact with eyes may cause irritation. If eyes are contacted, rinse thoroughly and contact physician if irritation persists. If skin is contacted, wash thoroughly with soap and water. Failure to comply may result in injury or death to personnel.

- f. Apply connector lubricant, Nyogel 760G, to connector (2) and connector (3).
- g. Connect connector (2) to connector (3).

**NOTE**

Install cable ties as required.

- h. Install connector lock (1) on connector (2) and connector (3).

**WARNING**

Anti-corrosion compound is toxic. Use only in well-ventilated area. Use NIOSH/MSHA-approved respirator with dual organic vapor/mist and particulate cartridge. Do not get in eyes; wear chemical safety goggles and full face shield when using. Avoid contact with skin and wear rubber or plastic, solvent-resistant gloves. In case of contact, remove contaminated clothing and immediately wash area with soap and water. If eyes are contacted, flush eyes with large amounts of water for at least 15 minutes and get immediate medical attention. If swallowed, do not induce vomiting; contact a physician immediately. Failure to comply may result in injury or death to personnel.

- i. Apply anti-corrosion spray, 2233850, to cushion clips that were removed and installed.
- j. Perform all Follow-On Maintenance tasks.

**END OF TASK**

**END OF WORK PACKAGE**





---

## AIR COMPRESSOR REPLACEMENT

---

**Preconditions**

Park vehicle  
 Engine OFF  
 Wheels chocked  
 Power steering pump removed (WP 0276)  
 Radiator drained (Reservoir equipped) (WP 0176)  
 Radiator drained (Surge tank equipped)  
 (WP 0177)  
 Air system drained

**Tools and Special Tools**

Tool Kit, General Mechanic's: Automotive

**Materials/Parts**

Seal (Item 17)  
 O-ring (Item 19)  
 O-ring (Item 20)  
 O-ring (Item 21)

**Materials/Parts (continued)**

O-ring (Item 22)  
 O-ring (Item 23)  
 O-ring (Item 24)  
 Cap and Plug Set  
 Coolant, Engine  
 Lubricating Oil, Engine  
 Tags, Identification

**Personnel Required**

Two

**Follow-On Maintenance**

Install power steering pump (WP 0276)  
 Fill radiator (Reservoir equipped) (WP 0176)  
 Fill radiator (Surge tank equipped) (WP 0177)  
 Remove and stow wheel chocks

---

**REMOVAL****WARNING**

- **Engine components can become hot during normal operation. Allow engine to cool completely prior to performing this task. Failure to comply may result in injury to personnel.**
- **Ensure air system is drained prior to working on air system components. Failure to comply may result in injury or death to personnel.**
- **Air lines under pressure will move violently when removed. Ensure air system is drained prior to removing air lines. Failure to comply may result in injury or death to personnel.**

**NOTE**

- Tag and mark hoses and fittings prior to removal to ensure proper installation.
- Cap and plug hoses and fittings upon removal.

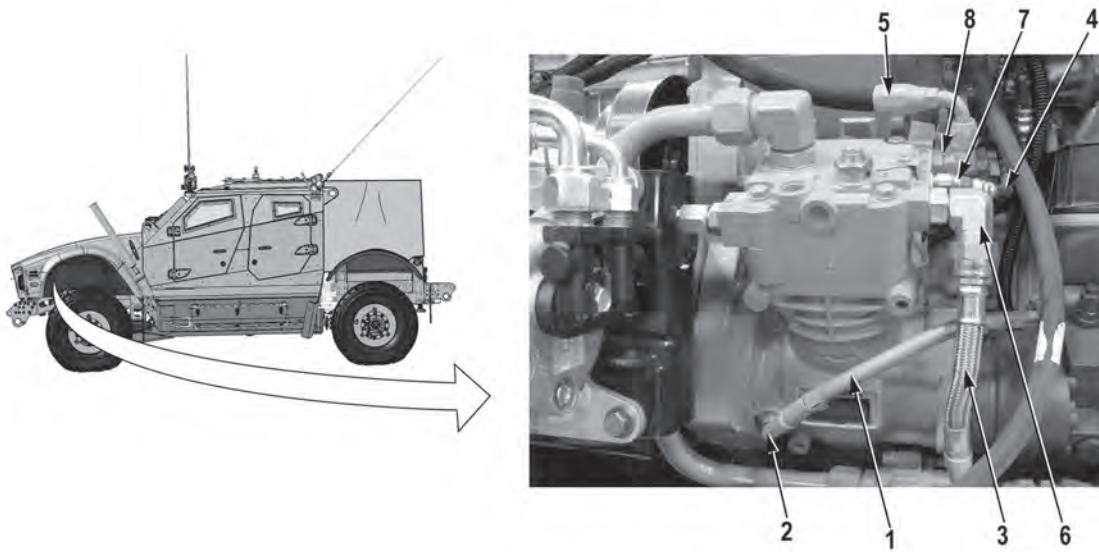

1. Remove hose (1) from fitting (2).

#### NOTE

Fitting (6) may be a 45 instead of a 90 degree fitting.

2. Remove three hoses (3, 4, and 5) from three fittings (6, 7, and 8).

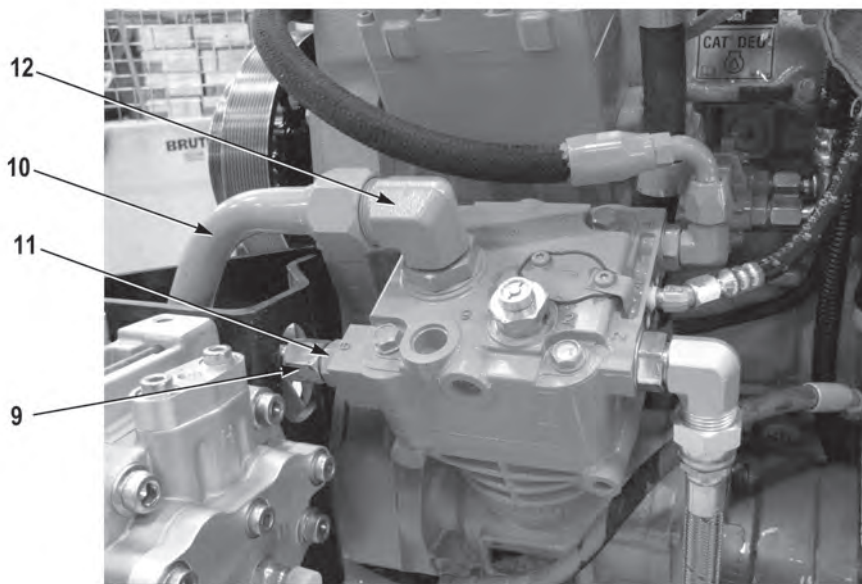

3. Remove two tubes (9 and 10) from two fittings (11 and 12).

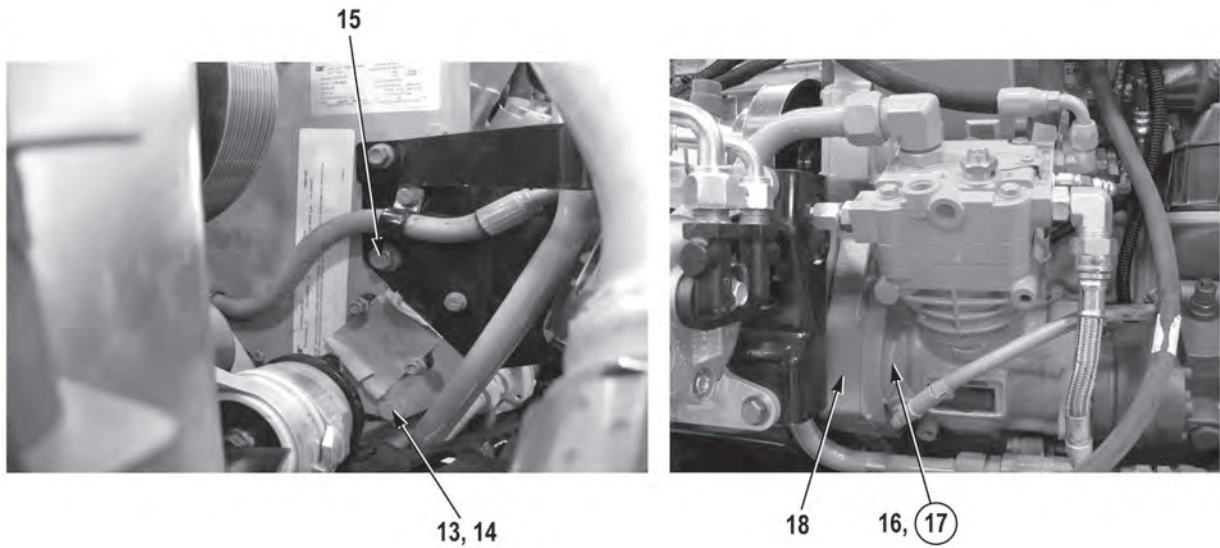

### **WARNING**

**Air compressor weighs 50 lbs (23 kg). Do not lift or move air compressor without the aid of an assistant. Failure to comply may result in injury or death to personnel.**

4. With the aid of an assistant, remove screw (13), washer (14), screw (15), air compressor (16), and seal (17) from engine (18). Discard seal (17).

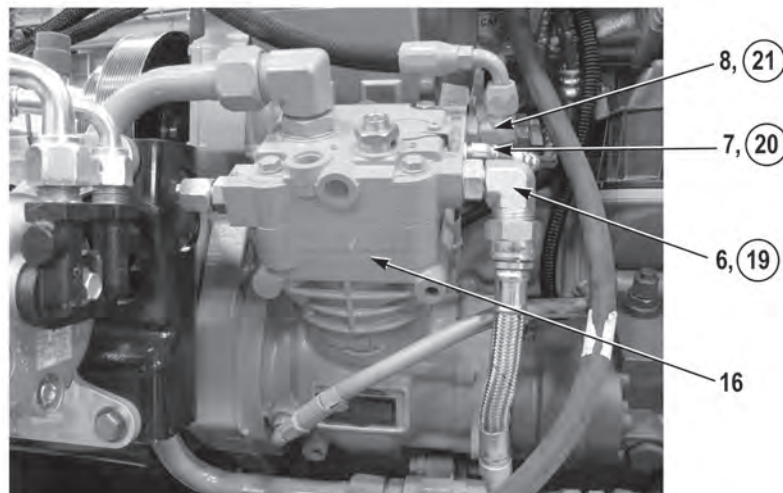

### **NOTE**

Note position of fittings prior to removal to ensure proper installation.

5. Remove three fittings (6, 7, and 8) and three O-rings (19, 20, and 21) from air compressor (16). Discard O-rings (19, 20, and 21).

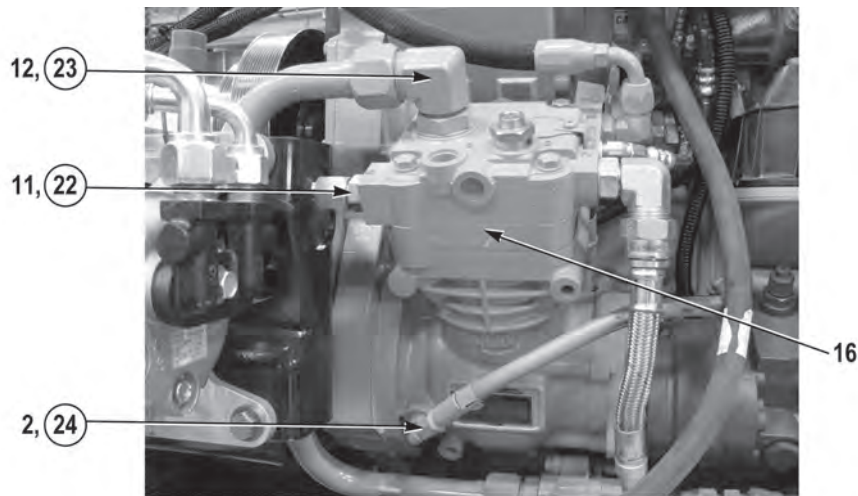

6. Remove two fittings (11 and 12) and two O-rings (22 and 23) from air compressor (16). Discard O-rings (22 and 23).
7. Remove fitting (2) and O-ring (24) from air compressor (16). Discard O-ring (24).

#### END OF TASK

#### INSTALLATION

#### NOTE

Install fittings as noted prior to removal.

1. Lightly lubricate two new O-rings (24 and 23) with clean oil and install two O-rings (24 and 23) and two fittings (2 and 12) on air compressor (16).
2. Lightly lubricate new O-ring (22) with clean coolant and install O-ring (22) and fitting (11) on air compressor (16).

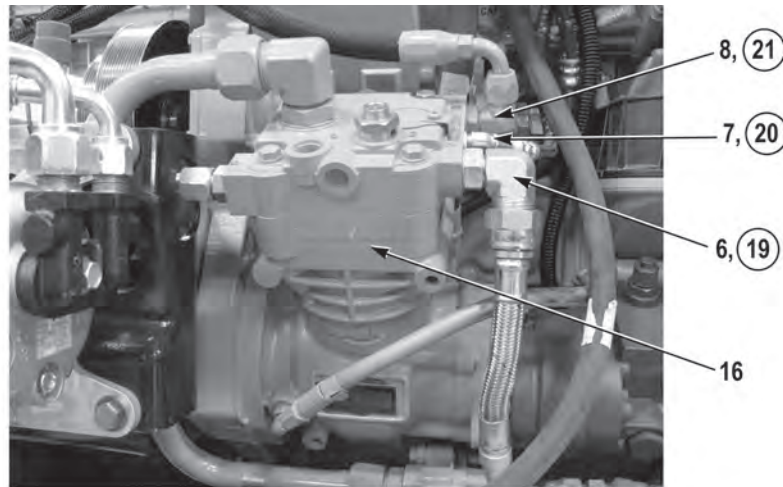

3. Lightly lubricate new O-ring (21) with clean coolant and install O-ring (21) and fitting (8) on air compressor (16).

#### **NOTE**

Fitting (6) may be a 45 instead of a 90 degree fitting.

4. Lightly lubricate two new O-rings (19 and 20) with clean oil and install two O-rings (19 and 20) and two fittings (6 and 7) on air compressor (16).

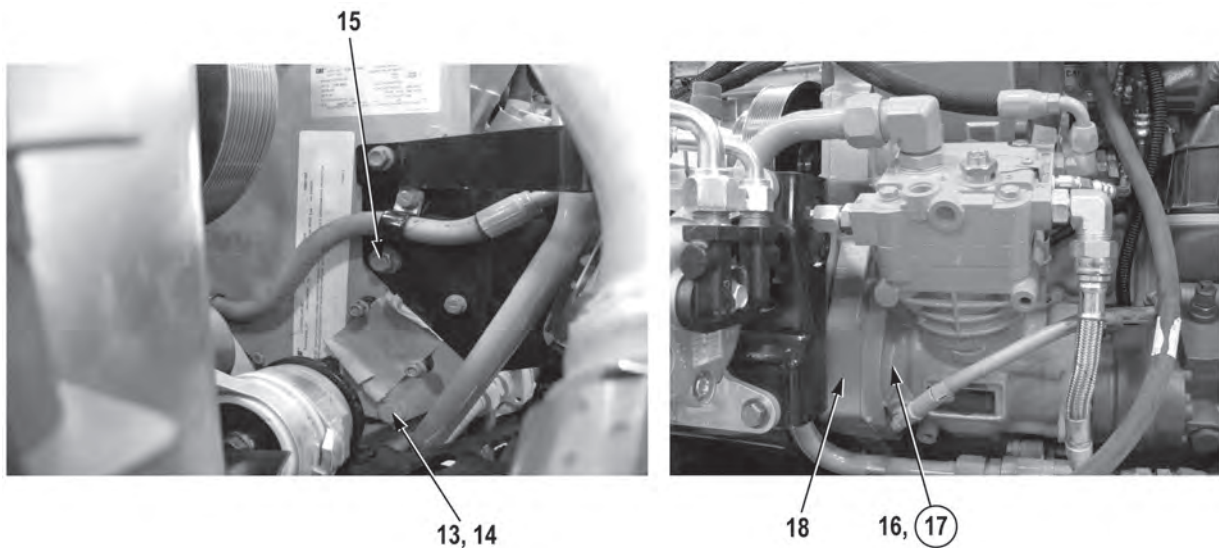

#### **WARNING**

**Air compressor weighs 50 lbs (23 kg). Do not lift or move air compressor without the aid of an assistant. Failure to comply may result in injury to personnel.**

5. Lightly lubricate new seal (17) with clean oil and with the aid of an assistant, install seal (17) and air compressor (16) on engine (18) with screw (15), washer (14), and screw (13).



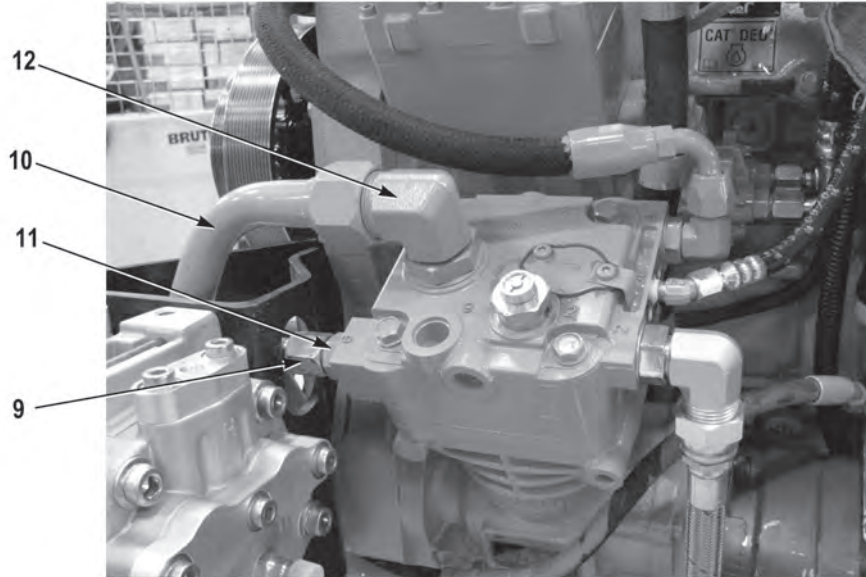

6. Install two tubes (9 and 10) on two fittings (11 and 12).

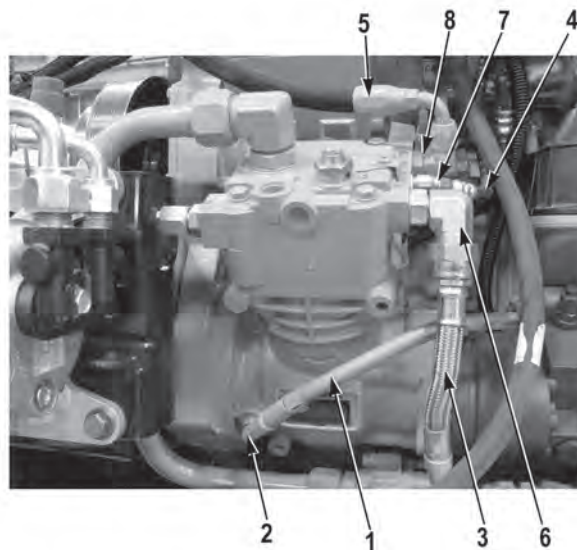
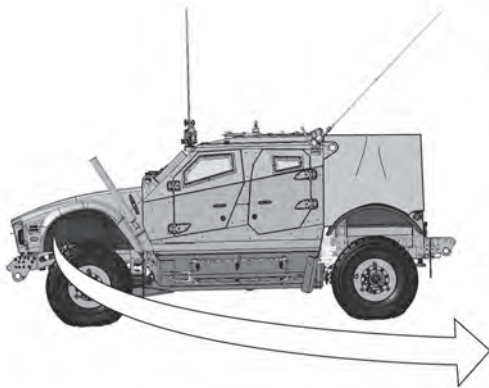

7. Install three hoses (3, 4, and 5) on three fittings (6, 7, and 8).
8. Install hose (1) on fitting (2).
9. Perform all Follow-On Maintenance tasks.

**END OF TASK**

**END OF WORK PACKAGE**



---

**AIR CONDITIONER DRIVE BELT REPLACEMENT**

---

**Preconditions**

Park vehicle  
Engine OFF  
Wheels chocked  
Hood opened and secured

**Materials/Parts**

None

**Follow-On Maintenance**

Close hood and secure  
Remove and stow wheel chocks

**Tools and Special Tools**

Tool Kit, General Mechanic's: Automotive

---

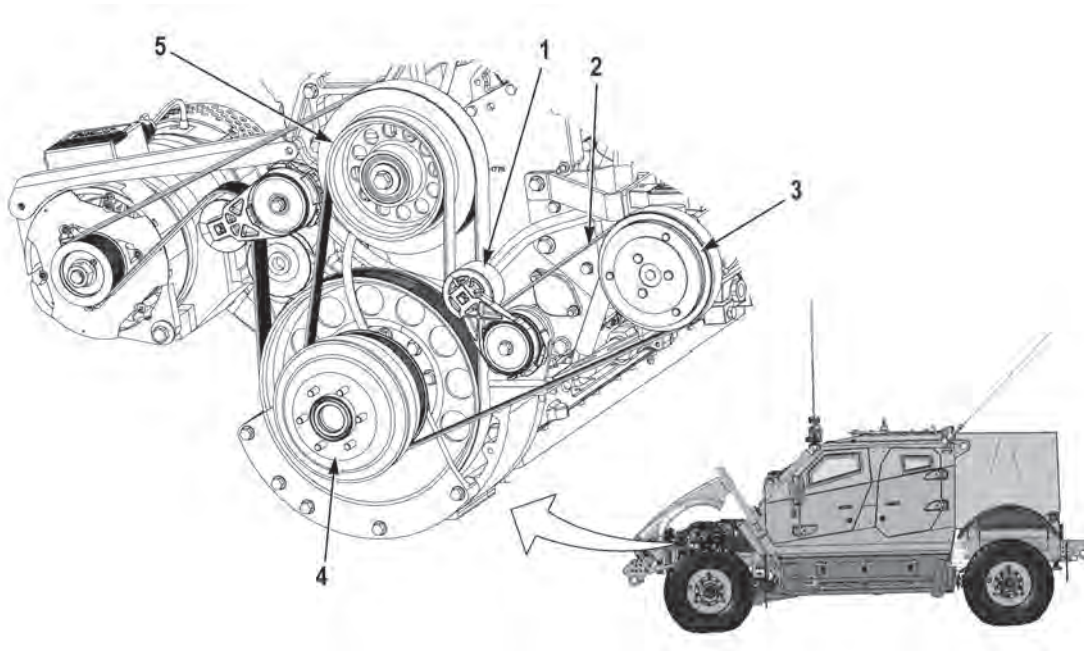
**REMOVAL****NOTE**

Note routing of belt prior to removal to ensure proper installation.

1. Using a breaker bar, release tension of belt tensioner idler pulley (1) and remove belt (2) from belt tensioner idler pulley (1), air conditioner compressor pulley (3), engine pulley (4), and idler pulley (5).

**END OF TASK**

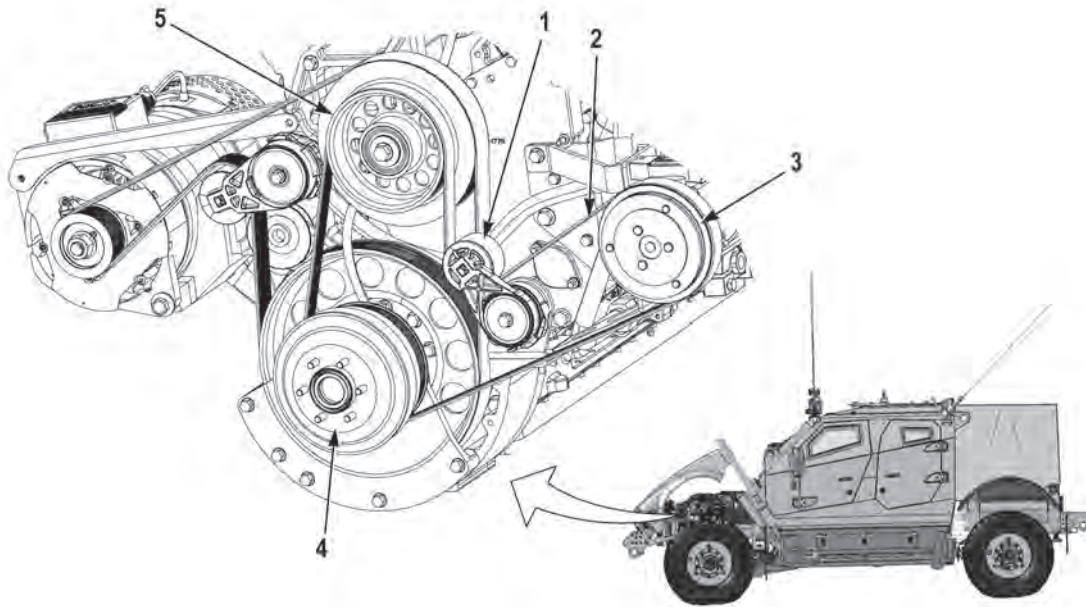
**INSTALLATION****NOTE**

Route belt as noted prior to removal.

1. Using a breaker bar, release tension of belt tensioner idler pulley (1) and install belt (2) on idler pulley (5), engine pulley (4), air conditioner compressor pulley (3), and belt tensioner idler pulley (1).
2. Perform all Follow-On Maintenance tasks.

**END OF TASK**

**END OF WORK PACKAGE**

---

**ALTERNATOR DRIVE BELT REPLACEMENT**

---

**Preconditions**

Park vehicle  
Engine OFF  
Wheels chocked  
Fan clutch removed (WP 0178)

**Materials/Parts**

None

**Follow-On Maintenance**

Install fan clutch (WP 0178)  
Remove and stow wheel chocks

**Tools and Special Tools**

Tool Kit, General Mechanic's: Automotive

---

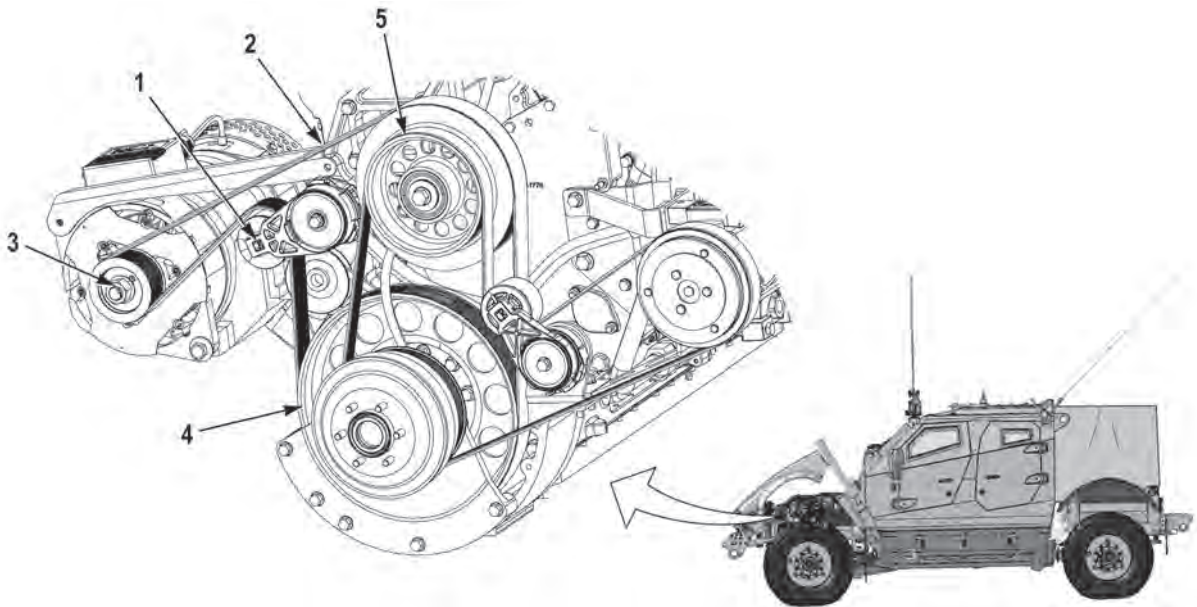
**REMOVAL****NOTE**

Note routing of belt prior to removal to ensure proper installation.

1. Using a breaker bar, release tension of belt tensioner idler pulley (1) and remove belt (2) from belt tensioner idler pulley (1), alternator pulley (3), engine pulley (4), and idler pulley (5).
2. Remove breaker bar.

**END OF TASK**

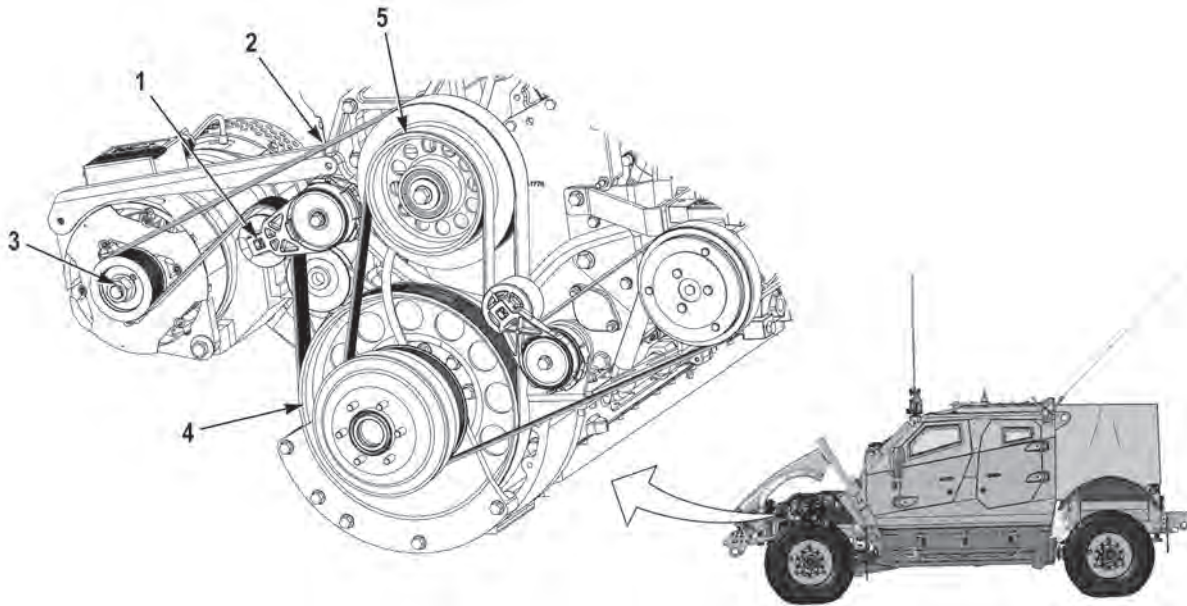
**INSTALLATION****NOTE**

Route belt as noted prior to removal.

1. Using a breaker bar, release tension of belt tensioner idler pulley (1) and install belt (2) on idler pulley (5), engine pulley (4), alternator pulley (3), and belt tensioner pulley (1).
2. Remove breaker bar.
3. Perform all Follow-On Maintenance tasks.

**END OF TASK**

**END OF WORK PACKAGE**

---

**CRANKSHAFT REAR SEAL REPLACEMENT**

---

**Preconditions**

Park vehicle  
 Engine OFF  
 Wheels chocked  
 Powertrain removed (WP 0227)

**Tools and Special Tools**

Bolt, Crankshaft Seal Installer  
 Drill, Electric, Portable  
 Drill Set, Twist  
 Locator Assembly  
 Nut Assembly  
 Seal Installer

**Tools and Special Tools (Continued)**

Slide Hammer Puller  
 Tool Kit, General Mechanic's: Automotive  
 Wrench, Torque, 20 to 100 ft-lb

**Materials/Parts**

Seal (Item 4)  
 Lubricating Oil, Engine

**Follow-On Maintenance**

Install powertrain (WP 0227)  
 Remove and stow wheel chocks

---

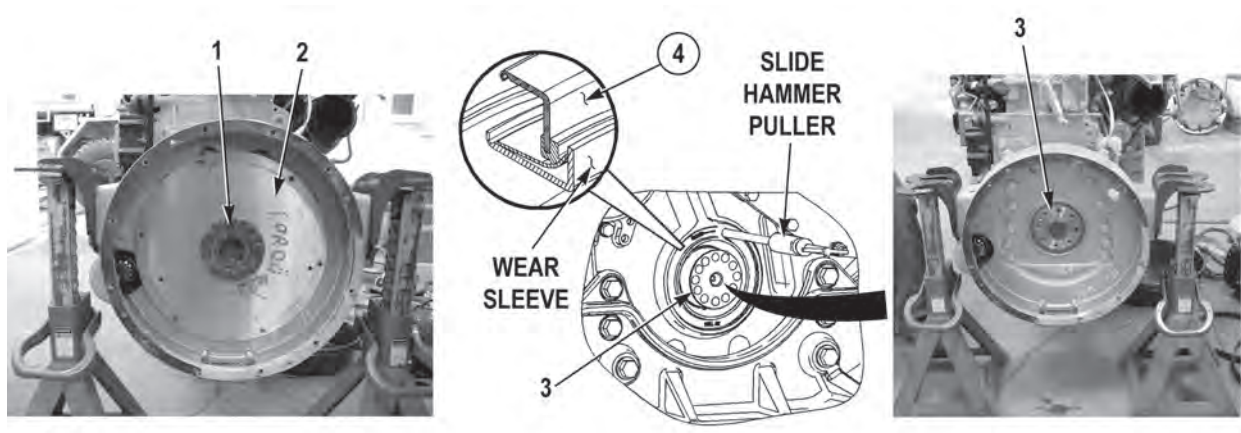
**REMOVAL**

1. Remove eight screws (1) and flexplate (2) from rear crankshaft (3).
2. Bend back lip of wear sleeve and remove wear sleeve.
3. Using a 1/16 in. (1.6 mm) drill bit, drill three holes, evenly spaced, in rear seal (4).
4. Using slide hammer puller, pull rear seal (4) from rear crankshaft (3).
5. Repeat Steps (3) and (4) until rear seal (4) is removed from rear crankshaft (3). Discard rear seal (4).

**END OF TASK**

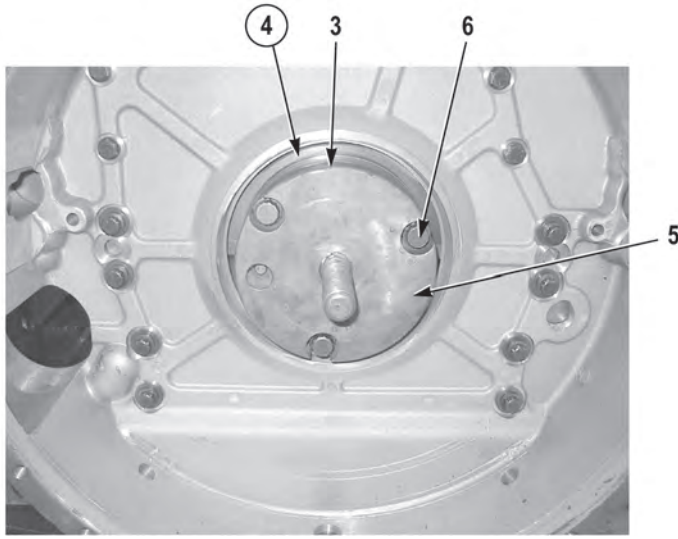

**INSTALLATION****NOTE**

Do not use any type of lubricant during the installation of the rear seal.

1. Clean outside diameter of rear crankshaft (3).
2. Install locator assembly (5) on rear crankshaft (3) with three crankshaft seal installer bolts (6).

**NOTE**

Ensure to install rear seal with arrow signifying direction of crankshaft rotation facing toward rear of engine.

3. Place new rear seal (4) on locator assembly (5).

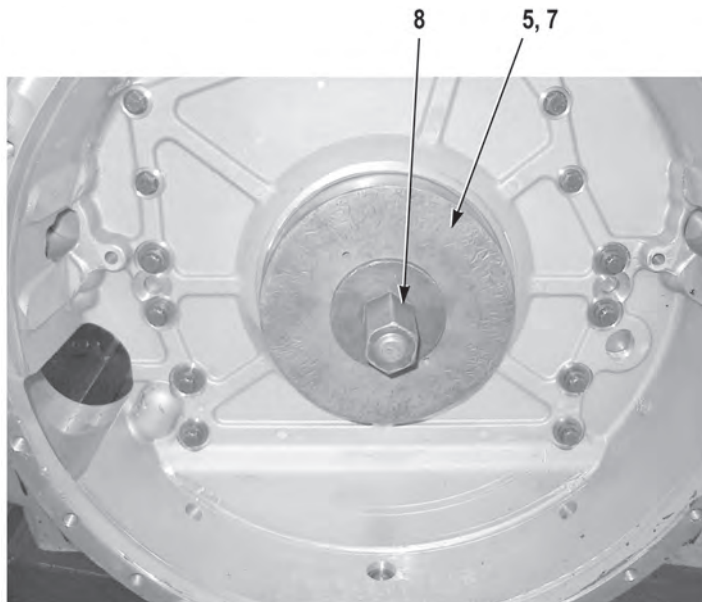

4. Install seal installer (7) on locator assembly (5)

5. Lubricate mating surface on nut assembly (8) with clean oil and install nut assembly (8) on locator assembly (5).
6. Tighten nut assembly (8) on locator assembly (5) until seal installer (7) makes contact with locator assembly (5).
7. Remove nut assembly (8) and seal installer (7) from locator assembly (5).
8. Remove three crankshaft seal installer bolts (6) and locator assembly (5) from rear crankshaft (3).

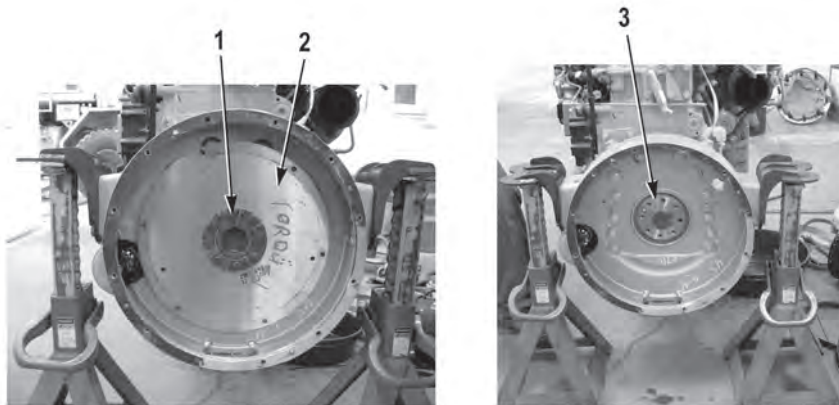

9. Install flexplate (2) on rear crankshaft (3) with eight screws (1). Tighten screws (1) to 90 lb-ft. (122 N•m).
10. Perform all Follow-On Maintenance tasks.

**END OF TASK**

**END OF WORK PACKAGE**





---

**ENGINE ELECTRONIC CONTROL MODULE (ECM) REPLACEMENT**

---

**Preconditions**

Park vehicle  
Engine OFF  
Wheels chocked  
Fuel/water separator filter removed (WP 0266)  
Power steering reservoir and bracket removed  
(WP 0277)

**Tools and Special Tools**

Socket, Deep Well, 1/2 in.  
Tool Kit, General Mechanic's: Automotive

**Materials/Parts**

Cap and Plug Set  
Tags, Identification  
Ties, Cable

**Follow-On Maintenance**

Install power steering reservoir and bracket  
(WP 0277)  
Install fuel/water separator filter (WP 0266)  
Remove and stow wheel chocks

---

**REMOVAL****WARNING**

**Engine components become hot during normal operation. Allow engine to cool completely prior to performing this task. Failure to comply may result in injury to personnel.**

**NOTE**

- Tag and mark hoses, lines, and fittings prior to removal to ensure proper installation.
- Cap and plug hoses, lines, and fittings upon removal.
- Remove cable ties as required.

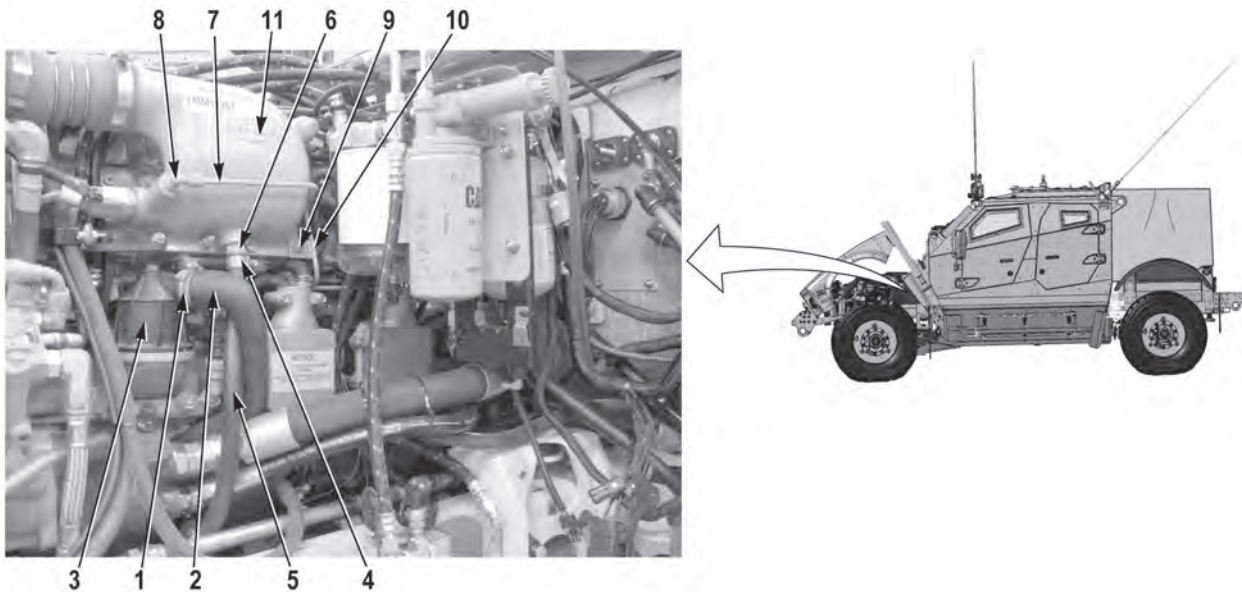

1. Remove clamp (1) and hose (2) from breather assembly (3).
2. Remove clamp (4) and hose (5) from fitting (6).
3. Remove tube (7) from fitting (8).

#### NOTE

- There are three cushion clips, one on driver side, passenger side, and rear of engine. Driver side cushion clip shown.
  - All cushion clips are removed the same way.
4. Remove nut (9), cushion clip (10), and tube (7) from air inlet (11).

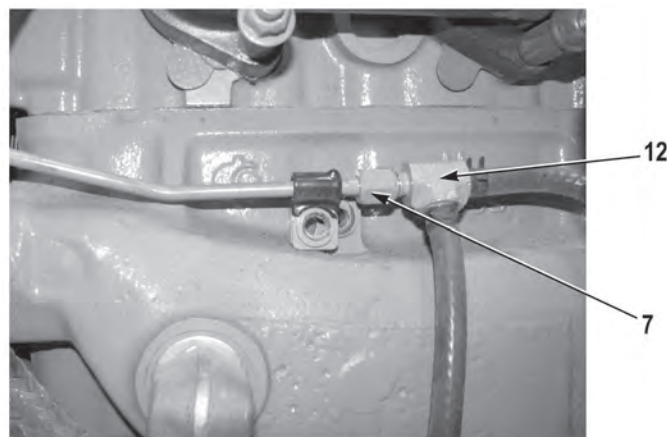

5. Remove tube (7) from fitting (12).

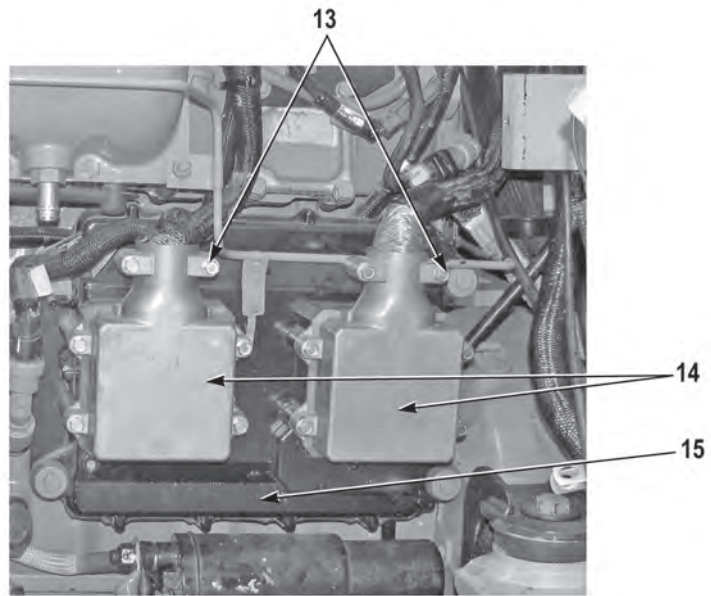

6. Remove 12 screws (13) and two connector covers (14) from electronic control module (15).

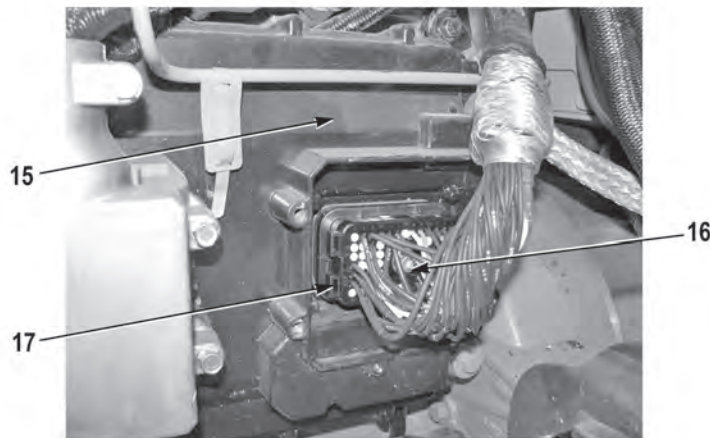

#### NOTE

Tag and mark connectors prior to removal to ensure proper installation.

7. Loosen two screws (16) and disconnect two connectors (17) from electronic control module (15).

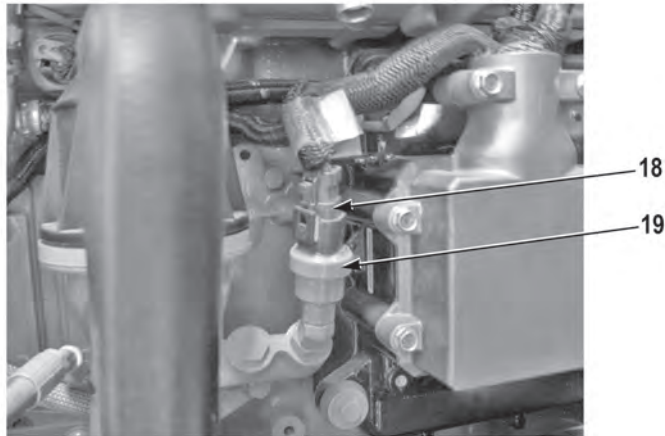

8. Disconnect connector (18) from connector (19).

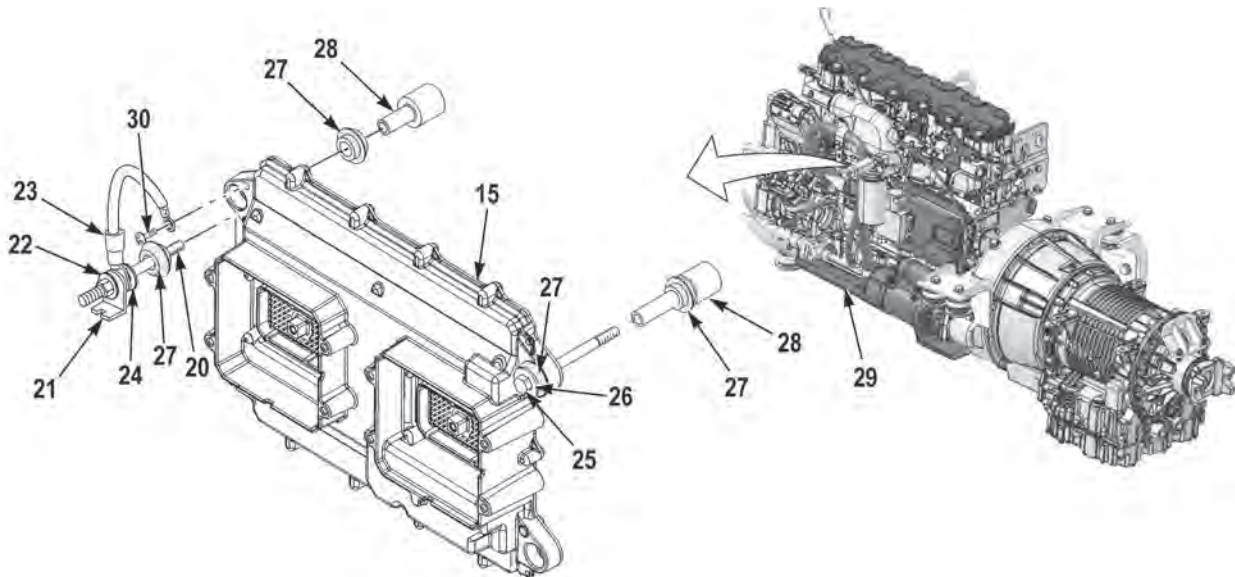

### NOTE

- Each mounting position uses two isolation mounts, one on either side of electronic control module, and a spacer between electronic control module and engine.
  - Note position of mounting hardware prior to removal to ensure proper installation.
9. Remove stud (20), standoff bracket (21), washer (22), ground strap (23), and washer (24) from electronic control module (15).
10. Remove three screws (25), washers (26), eight isolation mounts (27), electronic control module (15), and four spacers (28) from engine (29).
11. Remove screw (30) and ground strap (23) from electronic control module (15).

**END OF TASK**

**INSTALLATION**

1. Install ground strap (23) on electronic control module (15) with screw (30).

**NOTE**

- Engine electronic control module must be reprogrammed by an engine OEM as soon as possible after installation. Engine will operate at approximately 95% capacity until engine is reprogrammed.
  - Install mounting hardware as noted prior to removal.
2. Install electronic control module (15) on engine (29) with four spacers (28), eight isolation mounts (27), three washers (26), and screws (25).
  3. Install ground strap (23) and standoff bracket (21) on electronic control module (15) with washer (24), washer (22), and stud (20).
  4. Connect connector (18) to connector (19).

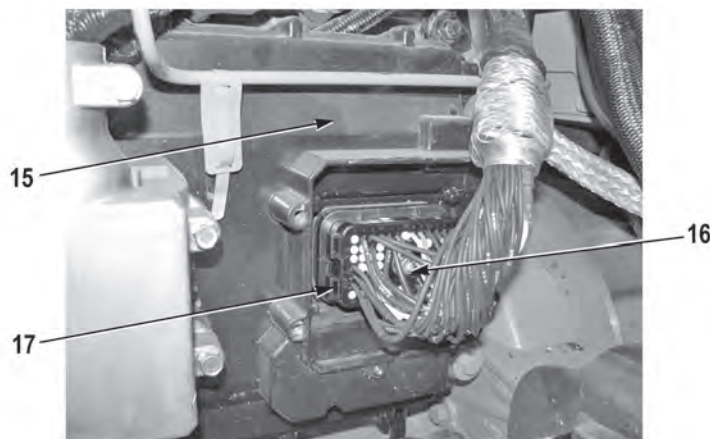

5. Connect two connectors (17) to electronic control module (15) and tighten two screws (16).

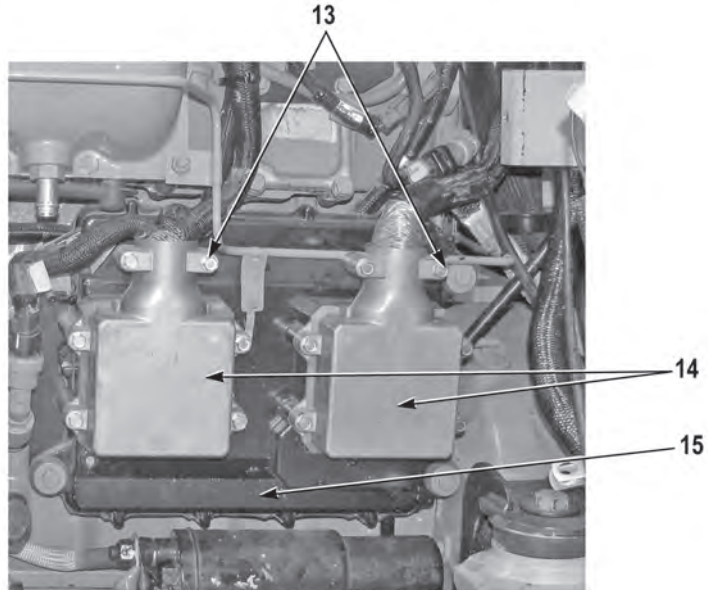
**NOTE**

Install cable ties as required.

6. Install two connector covers (14) on electronic control module (15) with 12 screws (13).

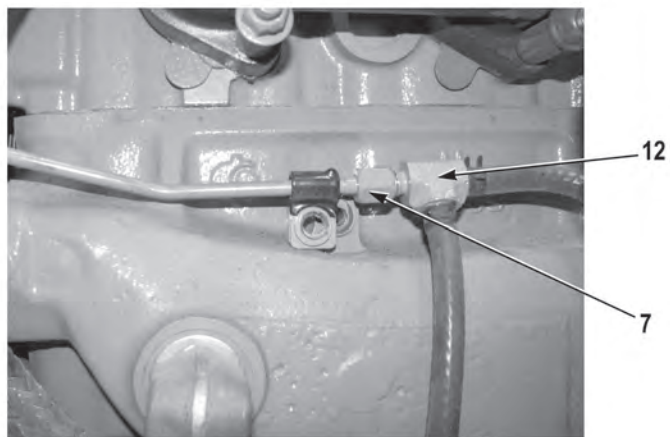

7. Install tube (7) on fitting (12).



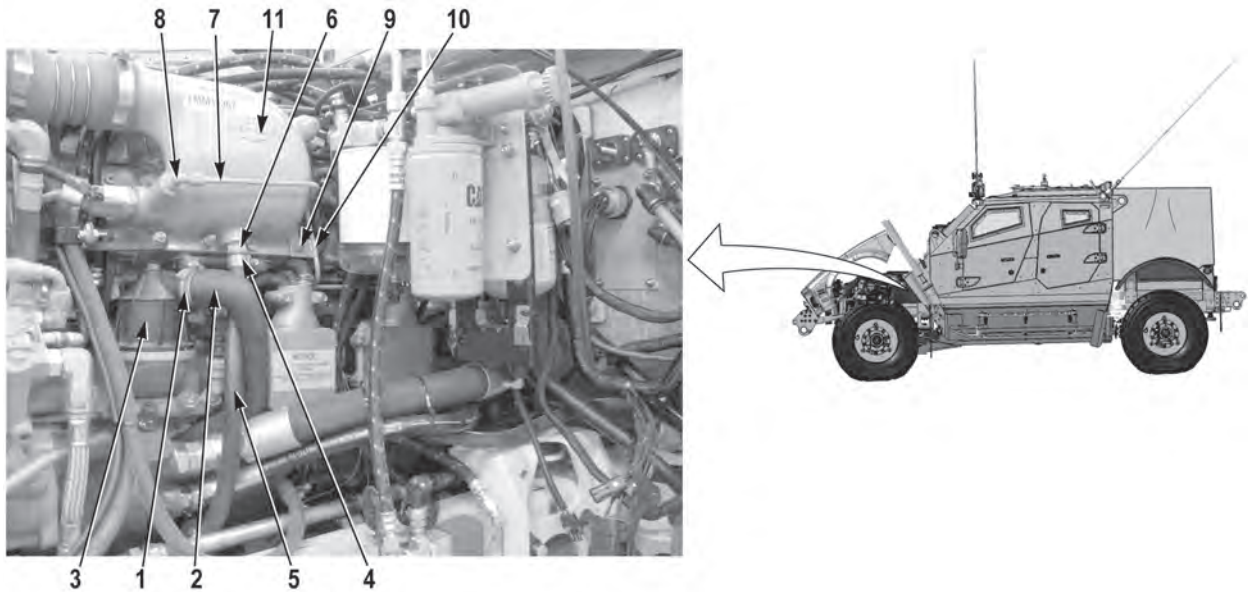

### NOTE

- There are three cushion clips, one on driver side, passenger side, and rear or engine. Driver side cushion clip shown.
- All cushion clips are installed the same way.

8. Install cushion clip (10) and tube (7) on air inlet (11) with nut (9).
9. Install tube (7) on fitting (8).
10. Install hose (5) on fitting (6) with clamp (4).
11. Install hose (2) on breather assembly (3) with clamp (1).
12. Perform all Follow-On Maintenance tasks.

**END OF TASK**

**END OF WORK PACKAGE**



---

**ENGINE OIL DRAIN/FILL**

---

**Preconditions**

Park vehicle  
Engine OFF  
Wheels chocked  
Hood opened and secured  
Underbody improvement panel removed  
(M1240A1) (WP 0056)  
Engine belly deflector panel removed (WP 0050)

**Tools and Special Tools**

Pan, DrainRemove and stow wheel chocks  
Tool Kit, General Mechanic's: Automotive  
Wrench, Torque, 15 to 75 lb-ft

**Materials/Part**

O-ring (Item 2)  
Lubricating Oil, Engine  
Rags, Wiping

**Follow-On Maintenance**

Install engine belly deflector panel (WP 0050)  
Underbody improvement panel installed  
(M1240A1) (WP0056)  
Close hood and secure

---

**DRAIN****WARNING**

**While engine is running, transmission MUST be in N (neutral), PARKING BRAKE must be set and properly engaged, and wheels MUST be chocked. Failure to comply may result in injury or death to personnel.**

**NOTE**

- Park vehicle on level surface prior to performing this task.
  - Perform Steps (1) through (3) for M1240 and M1245.
1. Start engine.

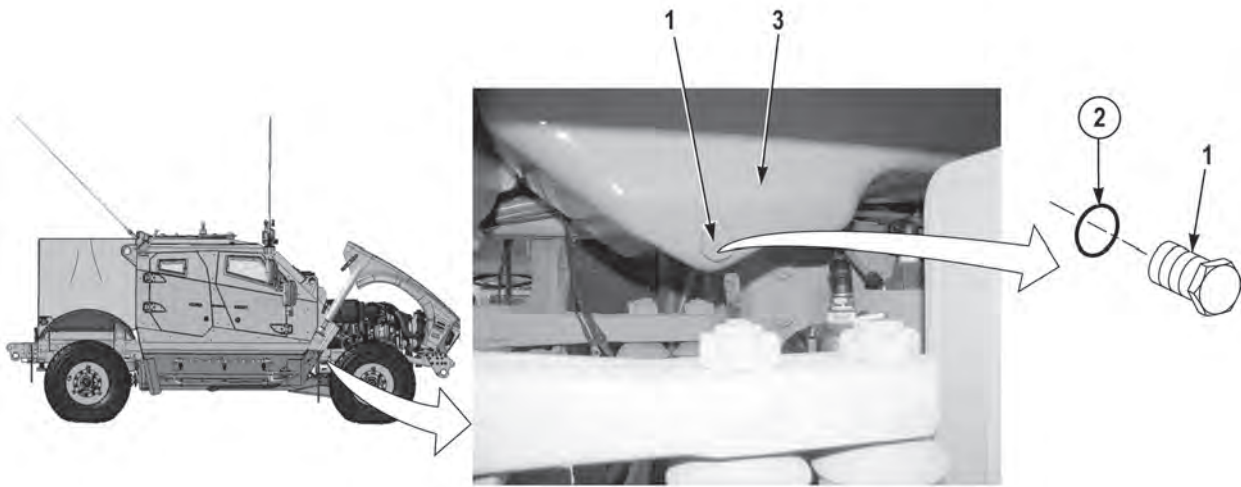

2. Turn steering wheel to left as far as possible to aid accessing drain plug (1).
3. Shut off engine.

### **WARNING**

**Ensure engine oil and filter are cool prior to removal. Failure to comply may result in injury to personnel.**

4. Position suitable drain pan under drain plug (1).
5. Remove drain plug (1) and O-ring (2) from oil pan (3) and allow oil to drain completely. Discard O-ring (2).
6. Lightly lubricate new O-ring (2) with clean oil and install O-ring (2) on drain plug (1).
7. Install drain plug (1) on oil pan (3). Tighten drain plug (1) to 39 to 67 lb-ft (55 to 85 N•m).
8. Replace engine oil filter (WP 0225).

**END OF TASK**

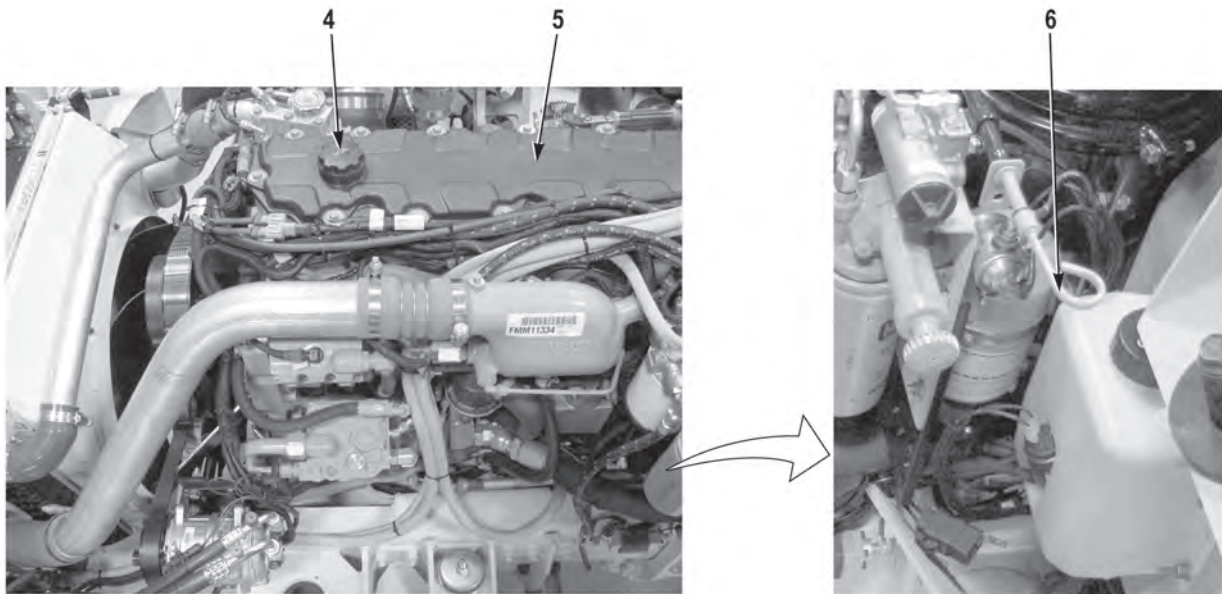
**FILL**

1. Remove cap (4) from valve cover (5).
2. Fill engine with lubrication oil through valve cover (5).
3. Install cap (4) on valve cover.
4. Using engine oil dipstick (6), check oil level. Add oil as needed.
5. Install engine belly deflector (M1240A1) (WP 0050).
6. Install underbody improvement panel (M1240A1) (WP 0056).
7. When full, start engine and run for 30 seconds.
8. Shut off engine.
9. After ten minutes recheck oil on dipstick (6) and fill, as needed, through valve cover (5).
10. Perform all Follow-On Maintenance tasks.

**END OF TASK****END OF WORK PACKAGE**



---

**ENGINE OIL FILTER REPLACEMENT**

---

**Preconditions**

Park vehicle  
Engine OFF  
Wheels chocked  
Hood opened and secured

**Tools and Special Tools**

Pan, Drain  
Tool Kit, General Mechanic's: Automotive  
Wrench, Filter

**Materials/Parts**

Oil, Filter (Item 1)  
Lubrication Oil, Engine

**Follow-On Maintenance**

Close hood and secure  
Remove and stow wheel chocks

---

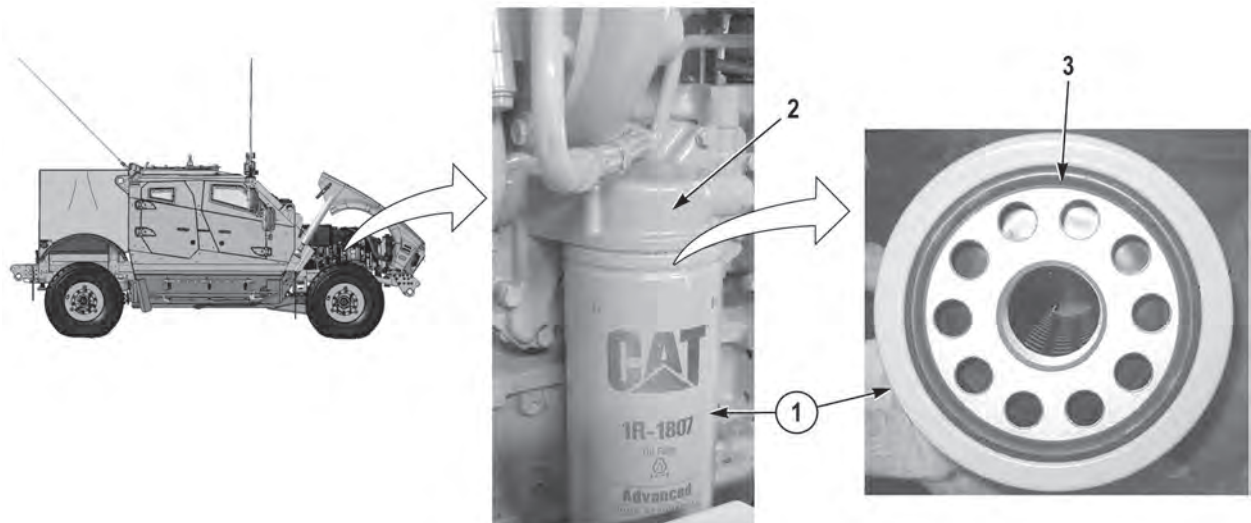
**REMOVAL**

1. Position drain pan under oil filter (1).

**WARNING**

**Ensure engine oil and filter are cool prior to removal. Failure to comply may result in injury to personnel.**

2. Remove oil filter (1) from oil filter base (2).

**END OF TASK**

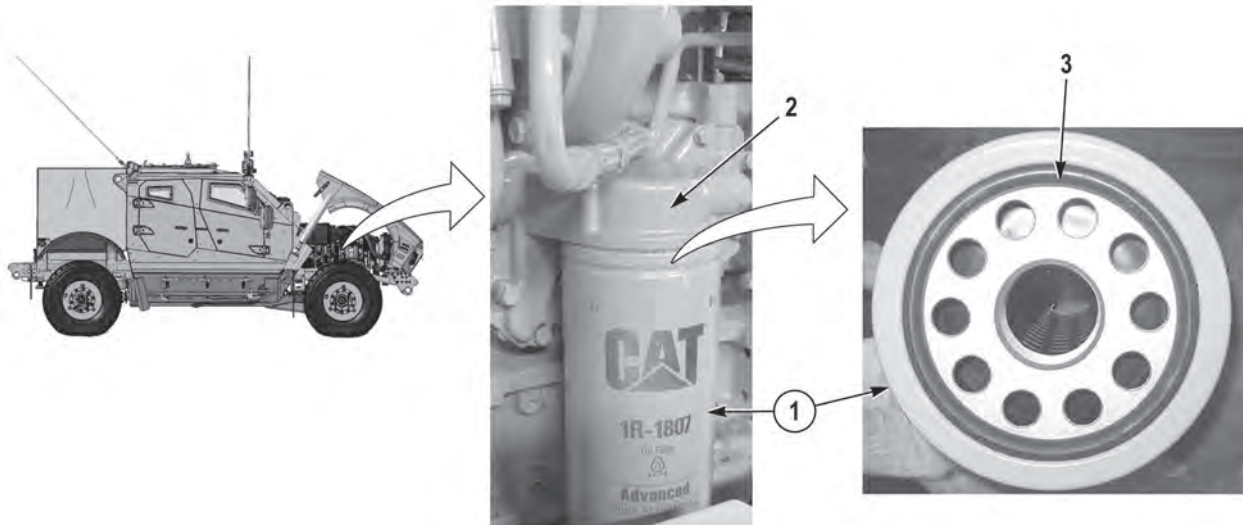

**INSTALLATION****CAUTION**

**Do not use a wrench to tighten oil filter housing. Failure to comply may result in damage to equipment.**

1. Lightly lubricate gasket (3) with clean oil and install gasket (3) and new oil filter (1) on base (2). Tighten oil filter (1) another 3/4 turn by hand.
2. Perform all Follow-On Maintenance tasks.

**END OF TASK****END OF WORK PACKAGE**

---

**PASSENGER SIDE ENGINE PANEL REPLACEMENT (M1240/M1245)**

---

**Preconditions**

Park vehicle  
 Engine OFF  
 Wheels chocked  
 Hood opened and secured  
 Air cleaner assembly removed (WP 0257)

**Materials/Parts**

Lockwasher (Item 6)

**Follow-On Maintenance**

Install air cleaner assembly (WP 0257)  
 Close hood and secure  
 Remove and stow wheel chocks

**Tools and Special Tools**

Tool Kit, General Mechanic's: Automotive

---

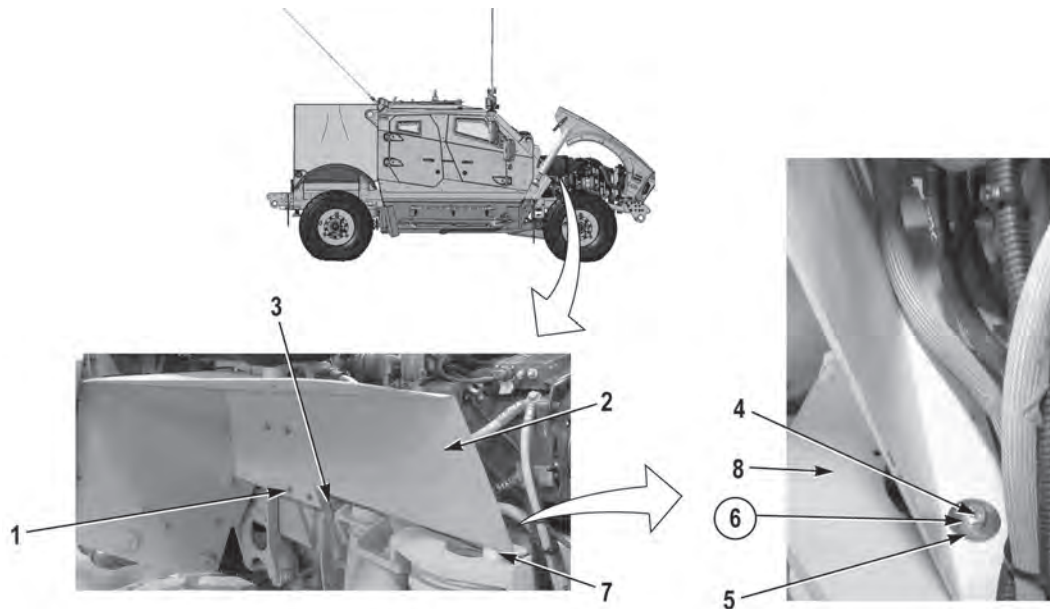
**REMOVAL**

1. Remove four screws (1) from engine panel (2) and bracket (3).
2. Remove screw (4), washer (5), lockwasher (6), spacer (7), and engine panel (2) from bulkhead (8). Discard lockwasher (6).

**END OF TASK**

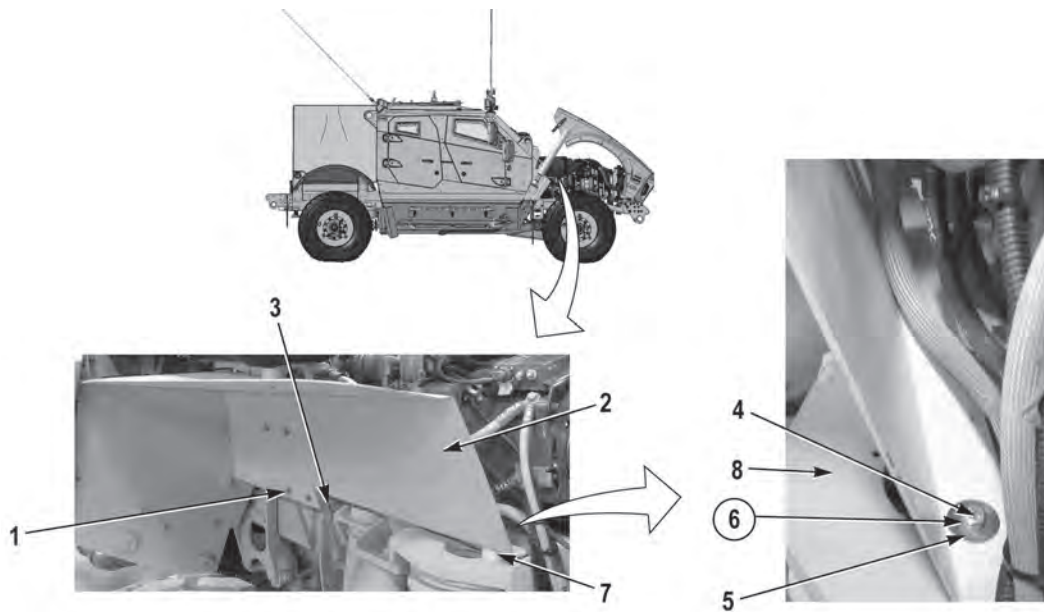
**INSTALLATION**

1. Install spacer (7) and engine panel (2) on bulkhead (8) with new lockwasher (6), washer (5), and screw (4).
2. Install four screws (1) on engine panel (2) and bracket (3).
3. Perform all Follow-On Maintenance tasks.

**END OF TASK****END OF WORK PACKAGE**

---

**POWERTRAIN REPLACEMENT**

---

**Preconditions**

Engine OFF  
 Wheels chocked  
 Parking brake applied  
 Cooling system assembly removed (WP 0175)  
 Air system drained  
 Engine oil drained (WP 0224)  
 Air cleaner assembly removed (M1240/M1245)  
 (WP 0257)  
 Air cleaner assembly removed (M1240A1)  
 (WP 0258)  
 Exhaust pipe removed (M1240/M1245)  
 (WP 0240)  
 Exhaust pipe removed (M1240A1) (WP 0239)  
 Surge tank removed (if equipped) (WP 0182)  
 Alternator removed (WP 0185)  
 Air conditioner compressor removed (original  
 compressor) (WP 0020)  
 Air conditioning compressor removed (updated  
 compressor) (WP 0019)  
 Power steering reservoir removed (WP 0277)  
 Fan clutch removed (WP 0178)

**Tools and Special Tools**

Adapter 3/8" to 1/2"  
 Cap and Plug Set  
 Jack Kit Hydraulic Hand Location  
 Jackstands (2)  
 Lifting Device  
 Pan, Drain  
 Shackle (TM 9-2355-335-10)  
 Sling, Engine and Transmission 3 Ton  
 Tool Kit, General Mechanic's: Automotive  
 Wrench, Torque, 300 in-lb  
 Wrench, Torque, 75 ft-lb  
 Wrench, 1-1/16 in.  
 Wrench, 1-5/8 in.  
 Wrench, 1-1/4 in.

**Materials/Parts**

Locknut (2) (Item 3)  
 Lockwasher (Item 15)  
 Lockwasher (Item 30)

**Materials/Parts (Continued)**

O-ring (Item 46)  
 O-ring (Item 52)  
 Locknut (Item 55)  
 Locknut (Item 57, 66)  
 Lockwasher (Item 70)  
 O-ring (Item 74)  
 O-ring (Item 77)  
 Locknut (2) (Item 97)  
 Locknut (3) (Item 97, 109)  
 Locknut (4) (Item 115, 122)  
 Locknut (Item 135)  
 Locknut (Item 138)  
 Locknut (Item 141)  
 Seal (151)  
 Cap and plug set  
 Compound, Sealing, Loctite 567  
 Lubricating Oil, Engine  
 Sealant, RTV  
 Tags, Identification  
 Ties, Cable

**Personnel Required**

Three

**Follow-On Maintenance**

Install fan clutch (WP 0178)  
 Install power steering reservoir (WP 0277)  
 Install air conditioner compressor (original  
 compressor) (WP 0020)  
 Install air conditioning compressor (updated  
 compressor) (WP 0019)  
 Install alternator (WP 0185)  
 Install surge tank (if equipped) (WP 0182)  
 Install exhaust pipe (M1240/M1245) (WP 0240)  
 Install exhaust pipe (M1240A1) (WP 0239)  
 Install air cleaner assembly (M1240/M1245)  
 (WP 0257)  
 Install air cleaner assembly (M1240A1)  
 (WP 0258)  
 Install cooling system assembly (WP 0175)  
 Remove and stow wheel chocks

---

## REMOVAL

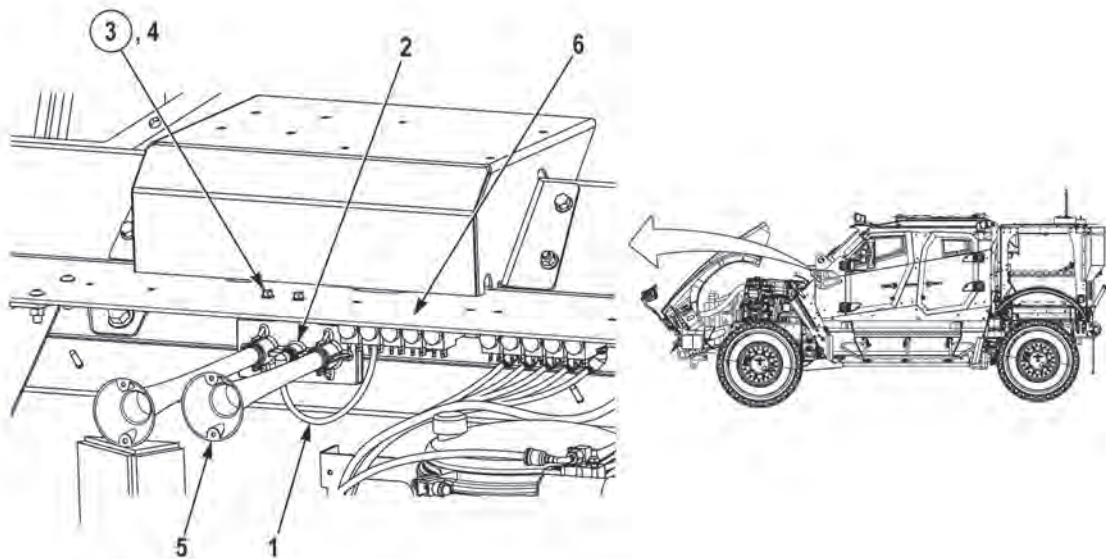

1. Remove underbody improvement panel, ladder panel, center belly deflector panel and passenger side belly deflector panel (WP 0056).
2. Remove propeller shaft (propeller shaft from transmission to transfer case) from transmission yoke (WP 0090).
3. Remove sprig support from bracket (WP 0234).

**WARNING**

- **Air system must be drained prior to removing air system components. Failure to comply may result in injury or death to personnel.**
- **Air lines under pressure will move violently when removed. Ensure air system is drained prior to removing air lines. Failure to comply may result in injury or death to personnel.**

**NOTE**

- Tag and mark air lines prior to removal to ensure proper installation.
  - Cap and plug air lines upon removal.
4. Remove air line (1) from fitting (2).
  5. Remove two locknuts (3), screws (4), and air horn (5) from hood support (6). Discard locknuts (3).

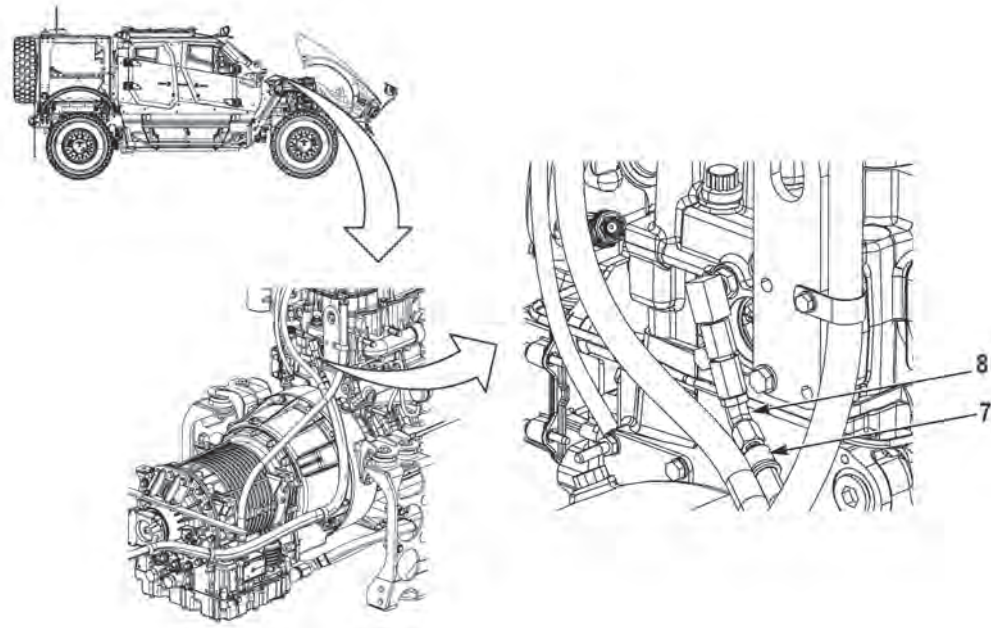

### **WARNING**

**Fuel is flammable and can explode. Keep fuel away from open flame and keep fire extinguisher within easy reach when working with fuel. Do not work on fuel system when engine is hot. Fuel can be ignited by hot engine. Smoking is prohibited while working with fuel. Failure to comply may result in injury or death to personnel.**

### **NOTE**

- Tag and mark hoses and fittings prior to removal to ensure proper installation.
  - Cap and plug hoses and fittings upon removal.
  - Position drain pan under hoses being removed.
  - Remove cable ties as required.
6. Remove fuel return hose (7) from fitting (8).

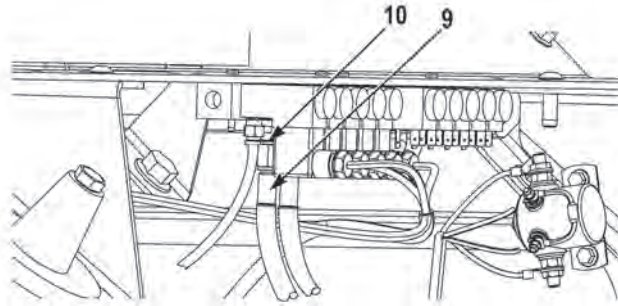

**NOTE**

- Tag and mark air lines and fittings prior to removal to ensure proper installation.
- Cap and plug air lines and fittings upon removal.

7. Remove air line (9) from fitting (10).

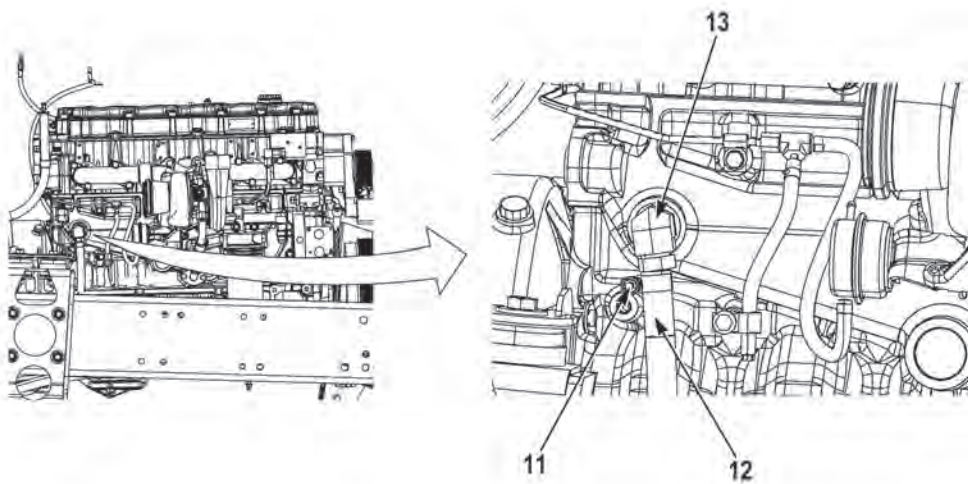

8. Remove clamp (11) and rear heater hose (12) from fitting (13).



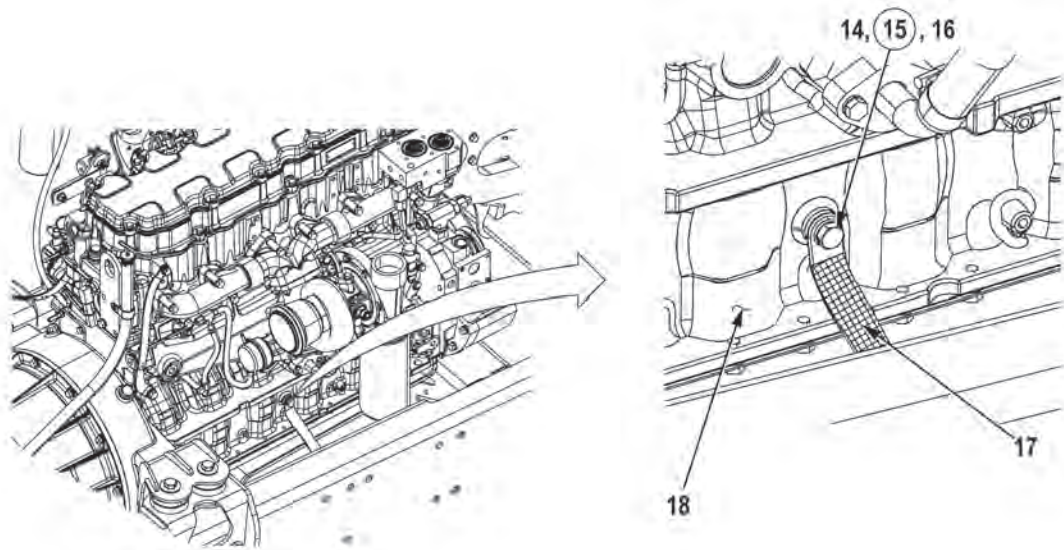

9. Remove screw (14), lockwasher (15), washer (16), and passenger side ground strap (17) from engine (18). Discard lockwasher (15).

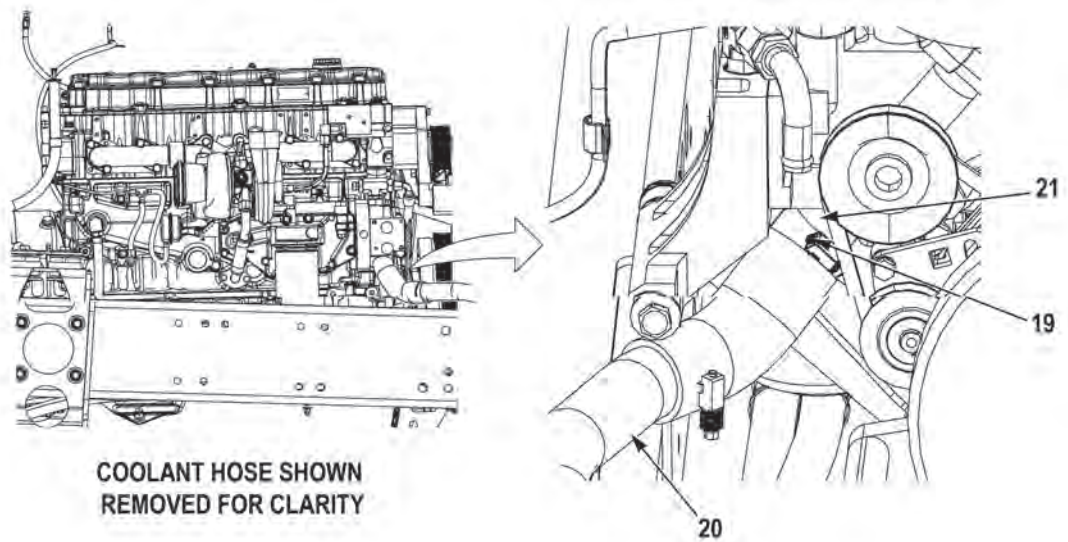

10. Remove clamp (19) and hose and tube assembly (20) from fitting (21).

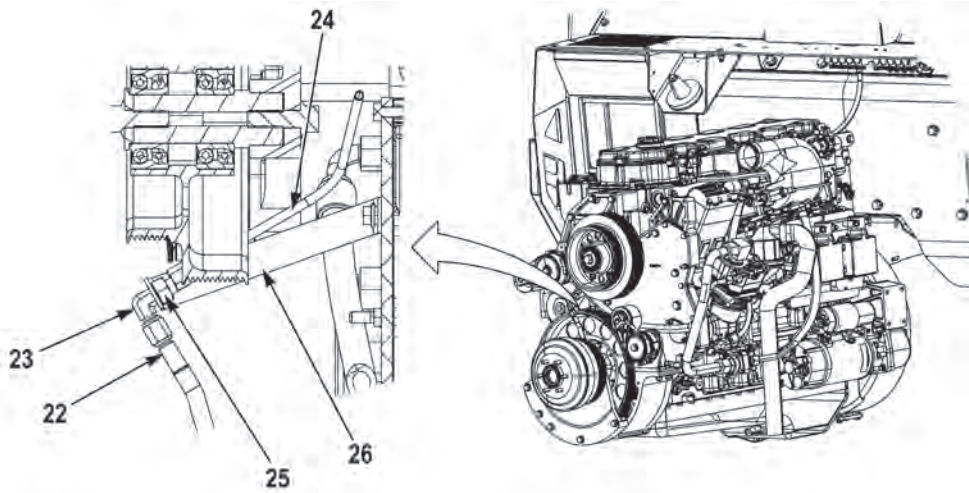

11. Remove air line (22) from fitting (23).
12. Remove air line tube (24) from fitting (23).

### NOTE

Note position of fitting prior to removal to ensure proper installation.

13. Remove nut (25) and fitting (23) from standoff bracket (26).

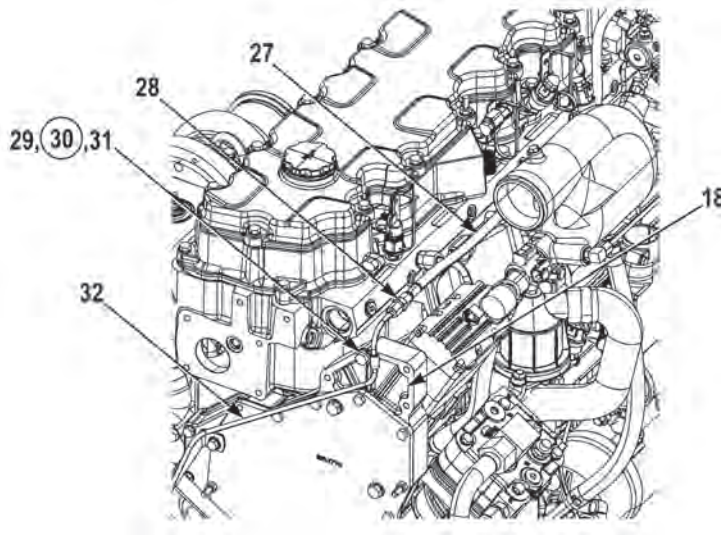

14. Remove air line (27) from fitting (28).
15. Remove screw (29), lockwasher (30), cushion clip (31), and air line tube (32) from engine (18). Discard lockwasher (30).

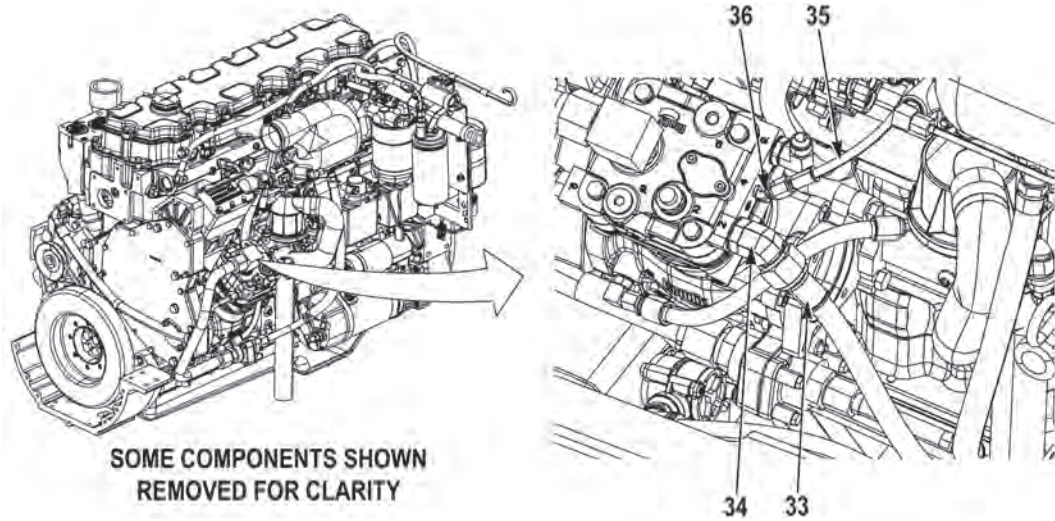

SOME COMPONENTS SHOWN  
REMOVED FOR CLARITY

### NOTE

Fitting (34) may be a 90 instead of a 45 degree fitting.

16. Remove air line (33) from fitting (34).
17. Remove air line (35) from fitting (36).

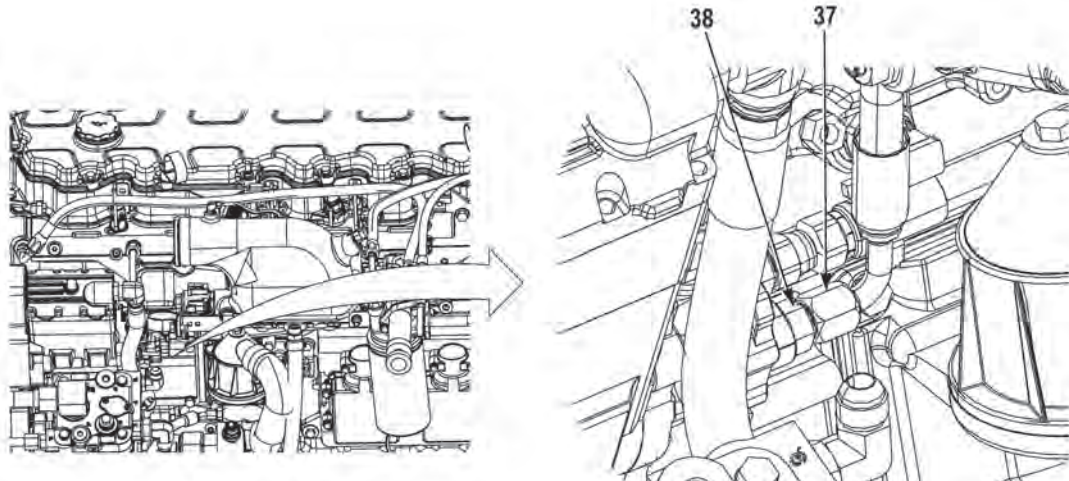

### WARNING

Fuel is flammable and can explode. Keep fuel away from open flame and keep fire extinguisher within easy reach when working with fuel. Do not work on fuel system when engine is hot. Fuel can be ignited by hot engine. Smoking is prohibited while working with fuel. Failure to comply may result in injury or death to personnel.

### NOTE

Perform Step (18) only if hose (37) is damaged.

18. Remove hose (37) from fitting (38).

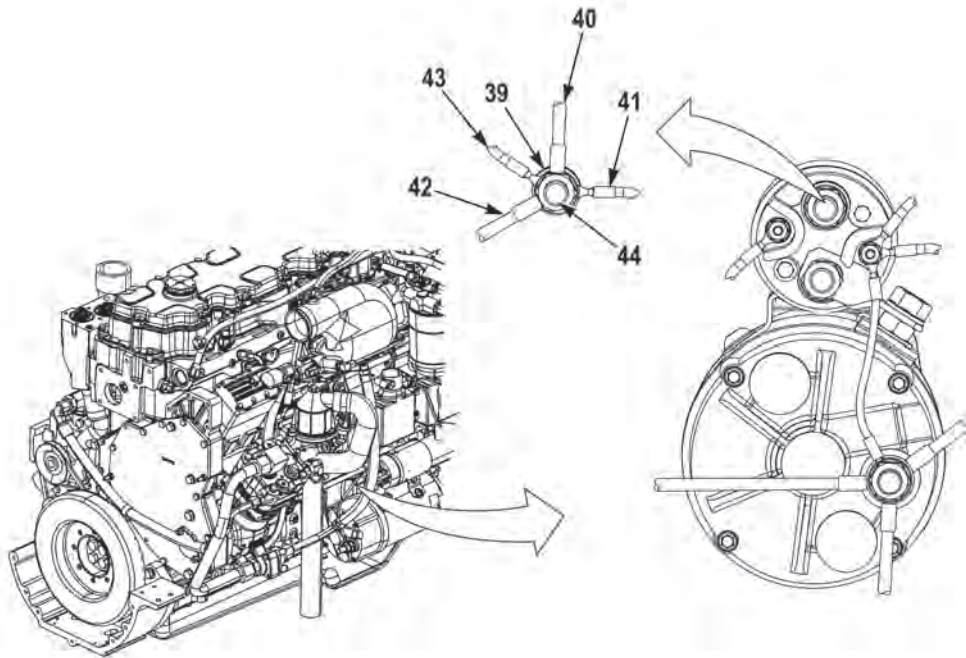

**NOTE**

Tag and mark cables and wires prior to removal to ensure proper installation.

19. Remove nut (39), cable (40), cable (41), cable (42), and wire (43) from stud (44).

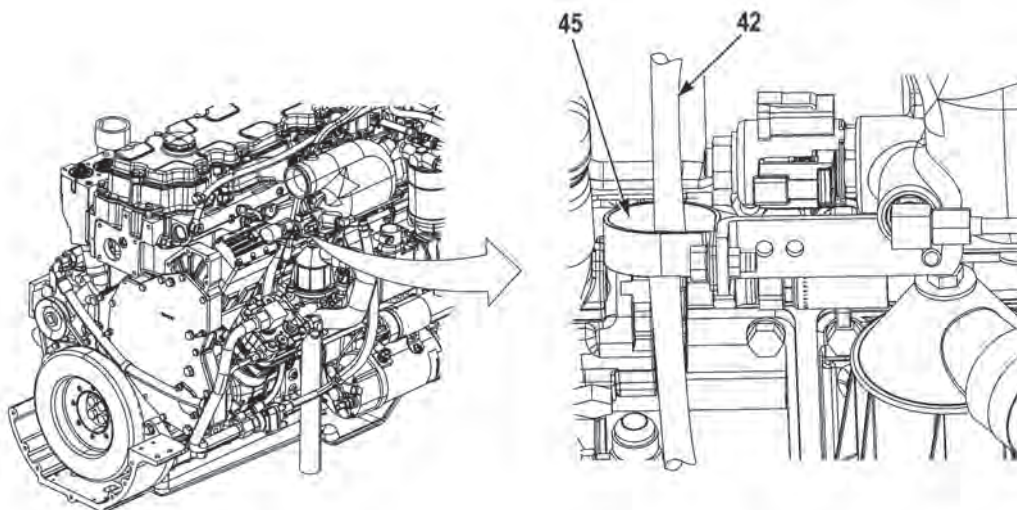
**NOTE**

Note routing of cable prior to removal to ensure proper installation.

20. Pull cable (42) through cushion clip (45) and lay aside.

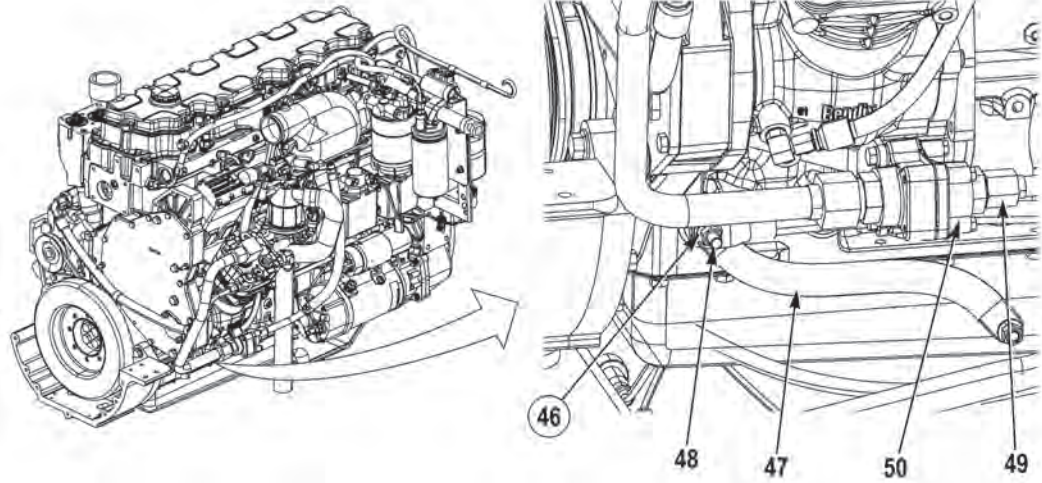

21. Remove locknut (46) and forward ground strap (47) from ground stud (48). Discard locknut (46).
22. Remove air compressor inlet air tube (49) from check valve (50).

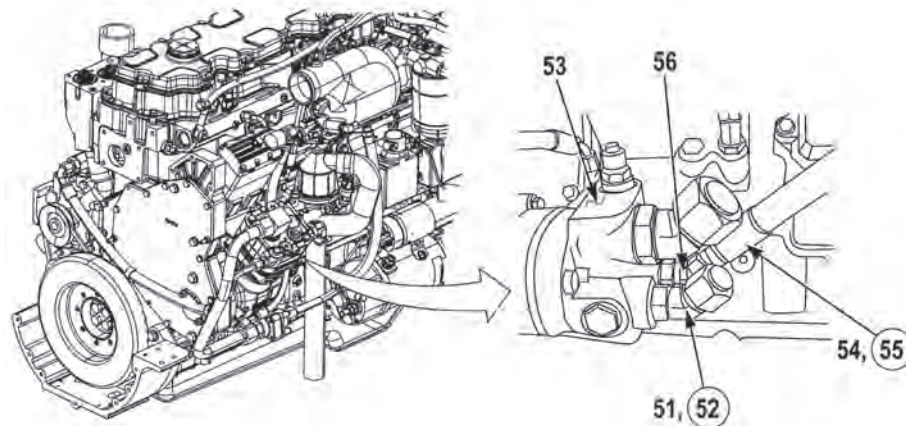

### NOTE

- Note position and orientation of fittings prior to removal to ensure proper installation.
- Fitting must be removed to aid in removal of inboard hose on power steering pump.

23. Remove fitting (51) and O-ring (52) from power steering pump (53).
24. Remove hose (54) and O-ring (55) from fitting (56). Discard O-ring (55).
25. Loosely install fitting (51) and O-ring (52) on power steering pump (53).

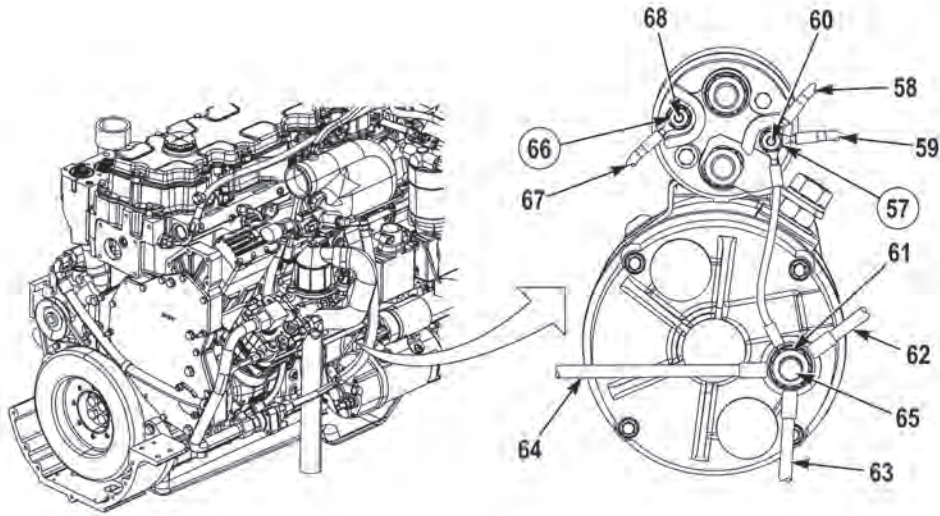

### NOTE

- Ground wire going from starter ground stud to starter solenoid should remain with starter solenoid. Reinstall locknut to retain ground wire.
- Note position of wires prior to removal to ensure proper installation.

26. Remove locknut (57), wire (58), and wire (59) from stud (60).

### NOTE

Ground wire going from starter ground stud to starter solenoid should remain with starter. Reinstall nut to retain ground wire.

27. Remove nut (61), cable (62), cable (63), and cable (64) from starter ground stud (65).

28. Remove locknut (66) and wire (67) from stud (68). Discard locknut (66).



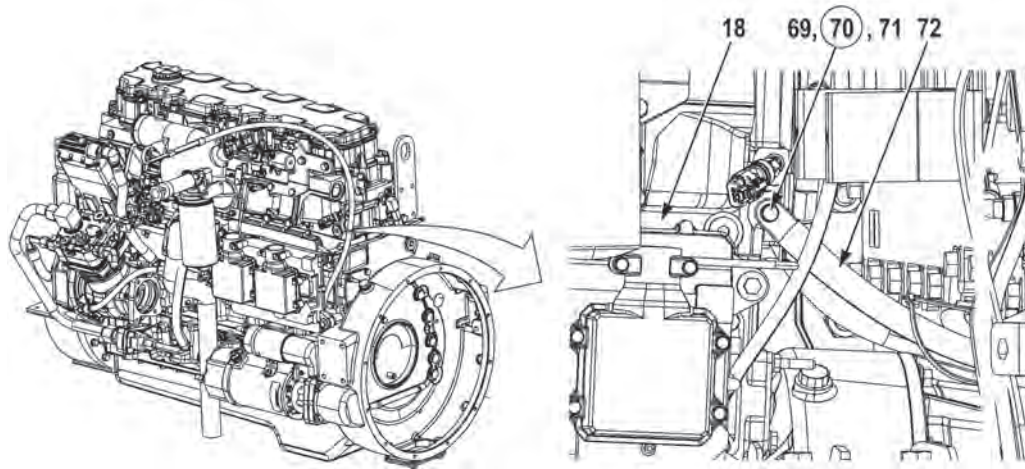

29. Remove screw (69), lockwasher (70), washer (71), and rear ground strap (72) from engine (18). Discard lockwasher (70).

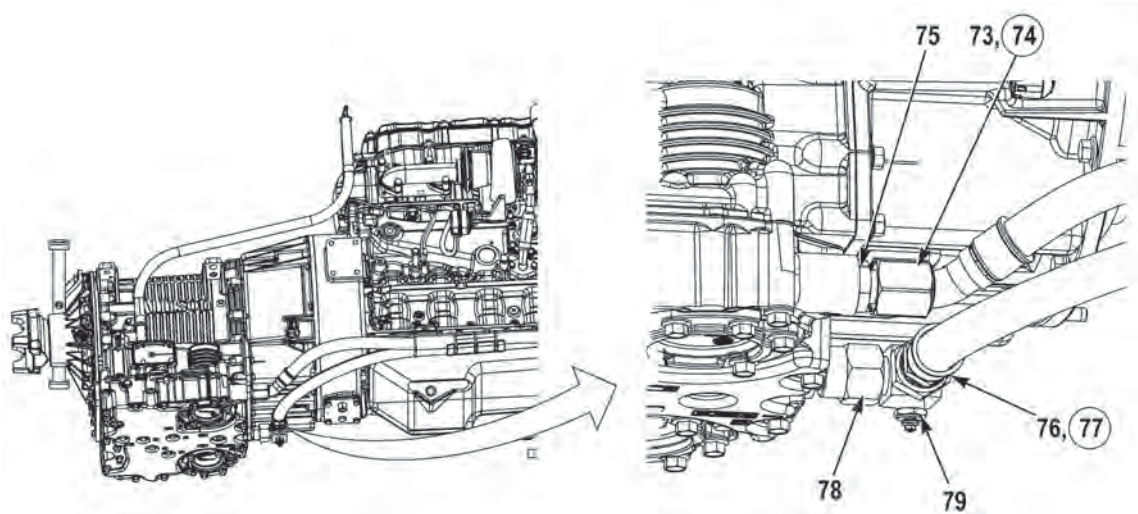

30. Remove hose (73) and O-ring (74) from fitting (75). Discard O-ring (74).
31. Remove hose (76) and O-ring (77) from fitting (78). Discard O-ring (77).
32. Remove transmission oil temperature sending unit (79) from fitting (78).



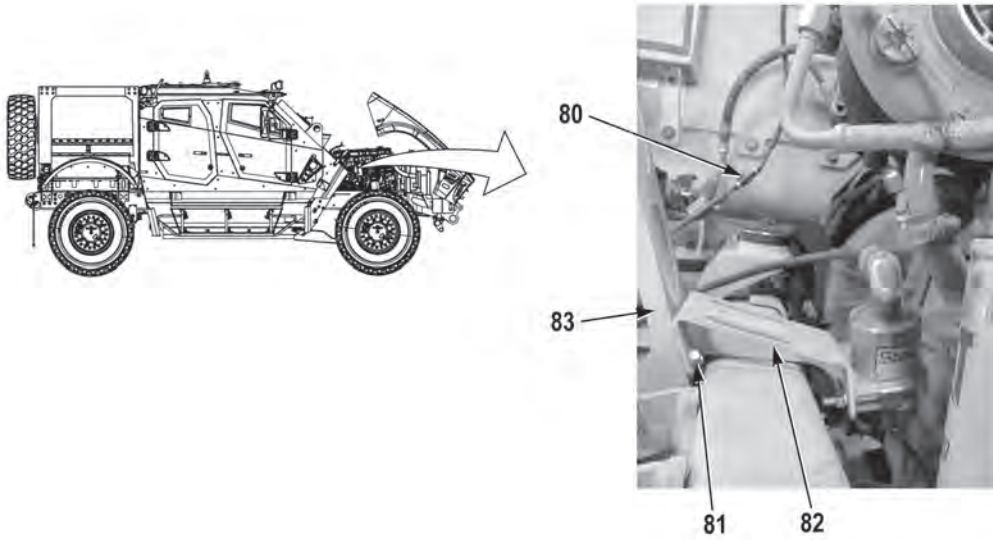

### NOTE

- Perform Steps (33) and (34) if equipped with five generator system.
- Remove cable ties as required.
- Tag and mark wire connectors prior to removal to ensure proper installation.

33. Disconnect connector (80).

34. Remove two screws (81) and bracket (82) from bracket (83).

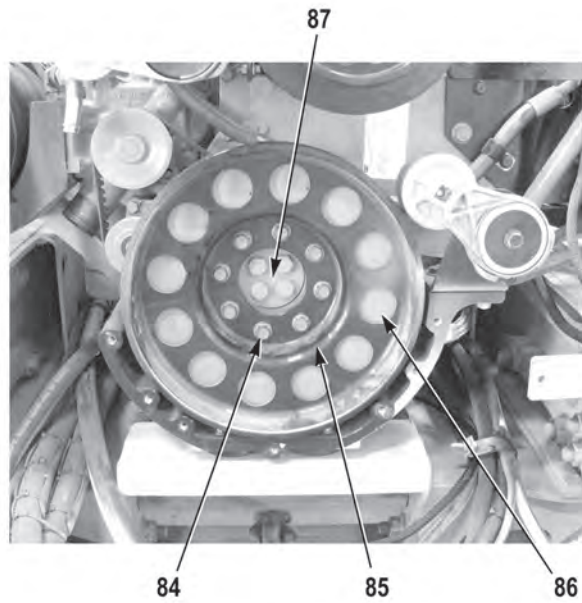

35. Remove eight screws (84), crankshaft pulley (85), and vibration damper (86) from crankshaft adapter (87).

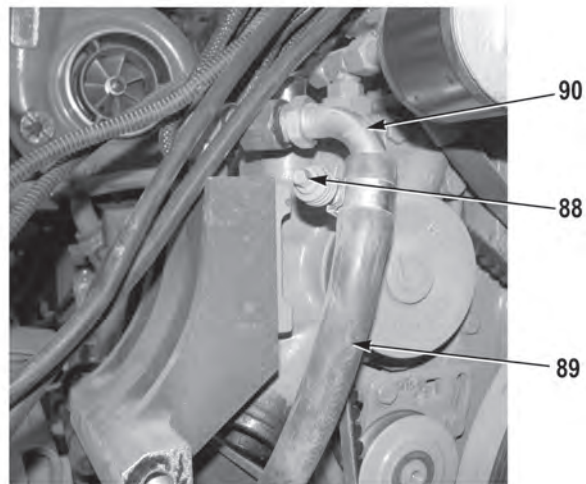

36. Loosen clamp (88) and remove hose (89) from fitting (90).

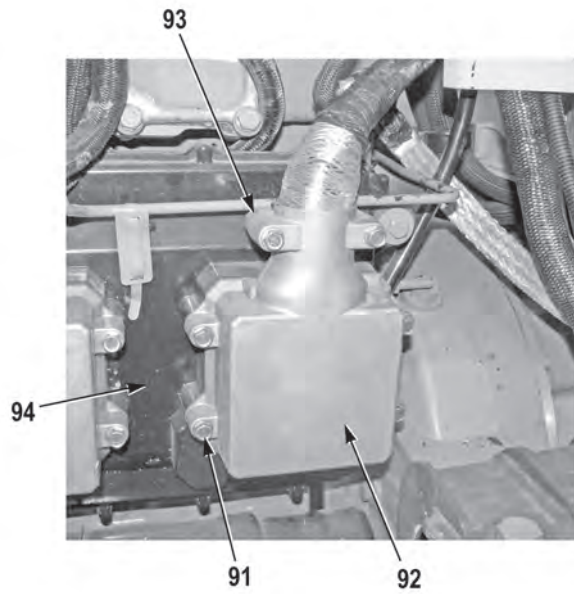

37. Remove six screws (91), cover (92), and retainer (93) from engine control unit (94).

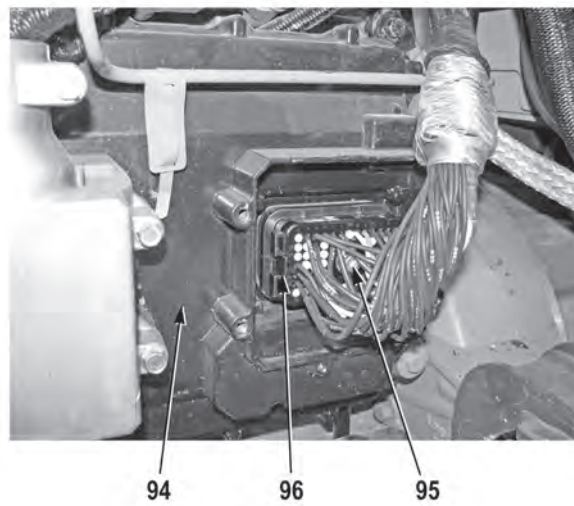

38. Loosen screw (95) and remove connector (96) from engine control unit (94).

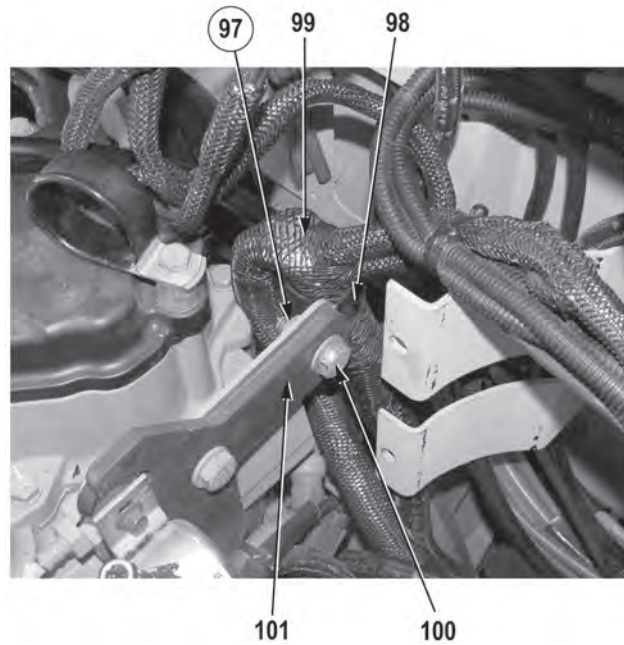

39. Remove locknut (97), cushion clip (98), engine harness (99), and screw (100) from bracket (101). Discard locknut (97).

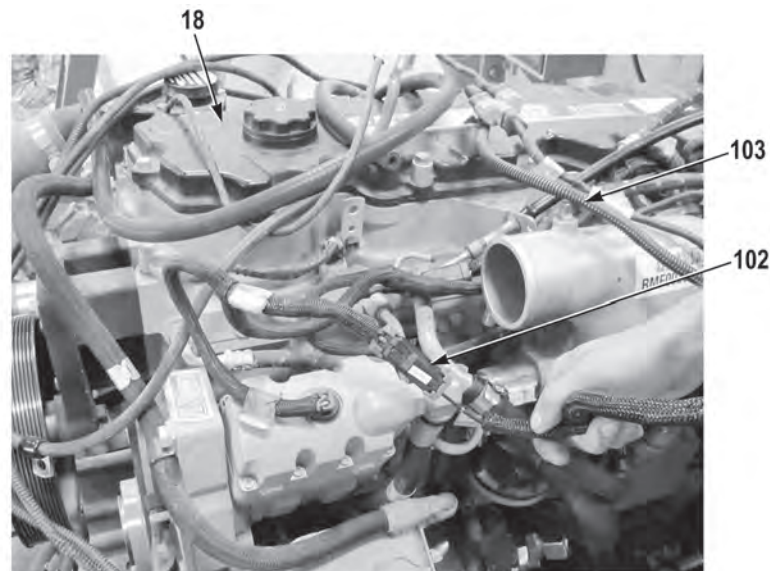

40. Disconnect connector (102).

#### NOTE

Note routing of wires and harnesses prior to removal to ensure proper installation.

41. Remove any remaining loose wires and harnesses (103) from top of engine (18) and set aside.



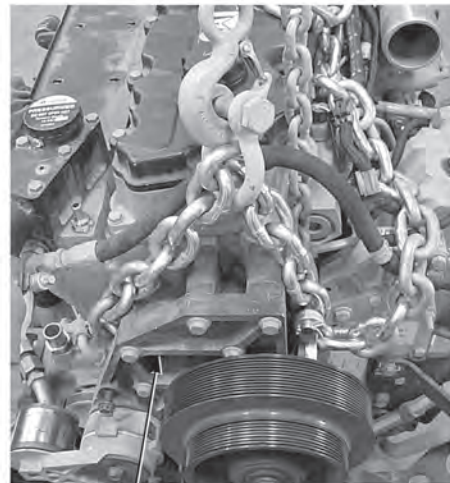

### **WARNING**

**Powertrain weighs 2,300 lbs (1 044 kg). Do not attempt to lift or move powertrain without the aid of two assistants and lifting device. Failure to comply may result in injury or death to personnel.**

### **NOTE**

When attaching lifting device, it will be helpful to allow front of engine to be slightly higher than transmission.

42. Attach lifting device to front accessory pulley bracket (104) and rear lift bracket (105).

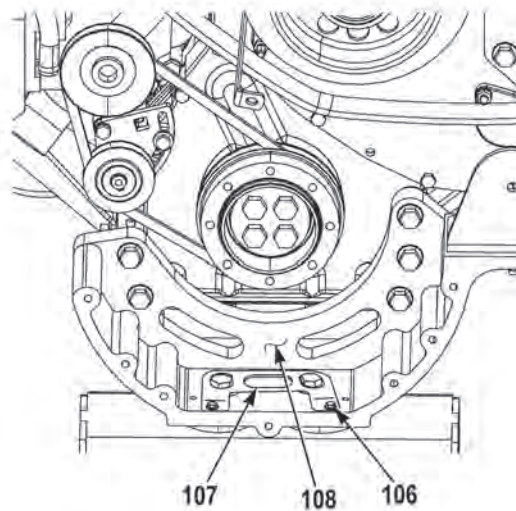
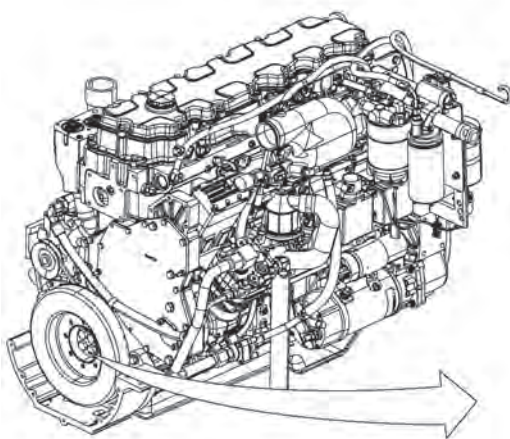

43. Remove two screws (106) and retainer plate (107) from engine front support (108).

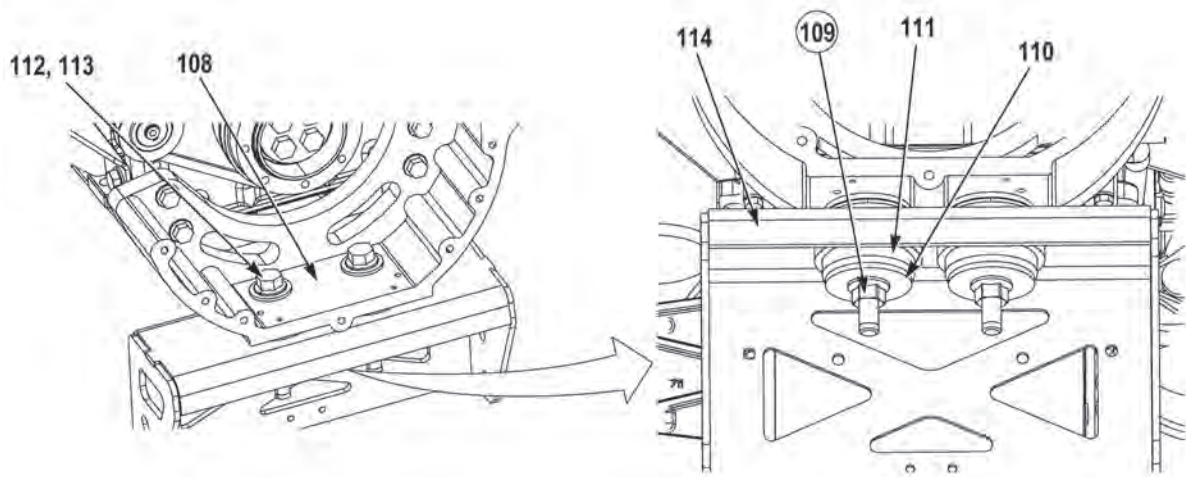

44. Remove two locknuts (109), washers (110), lower rubber mounts (111), screws (112), and washers (113) from crossover bracket (114) and engine front support (108). Discard locknuts (109).

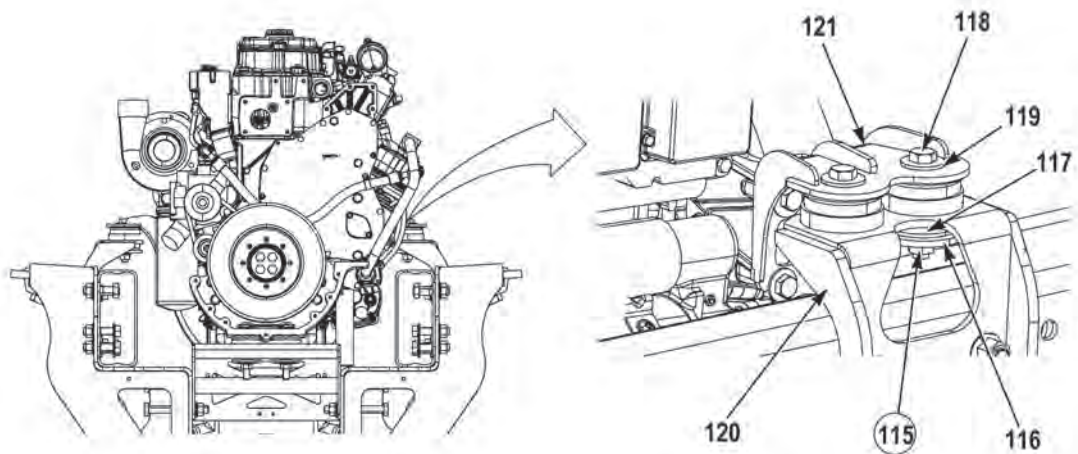

45. Remove two locknuts (115), washers (116), lower rubber mounts (117), screws (118), and washers (119) from driver side frame bracket (120) and mounting bracket (121). Discard locknuts (115).

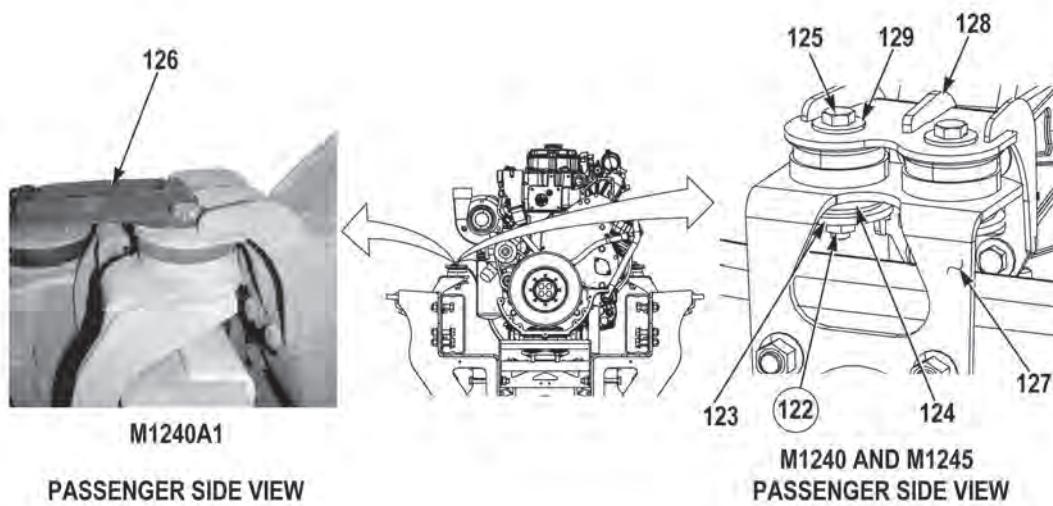

### NOTE

- Perform Step (46) for M1240A1 only.
  - Perform Step (47) for M1240 and M1245 only.
46. Remove two locknuts (122), washers (123), lower rubber mounts (124), screws (125), and exhaust standoff bracket (126) from passenger side frame bracket (127) and mounting bracket (128). Discard locknuts (122).
  47. Remove two locknuts (122), washers (123), lower rubber mounts (124), screws (125), and washers (129) from passenger side frame bracket (127) and mounting bracket (128). Discard locknuts (122).



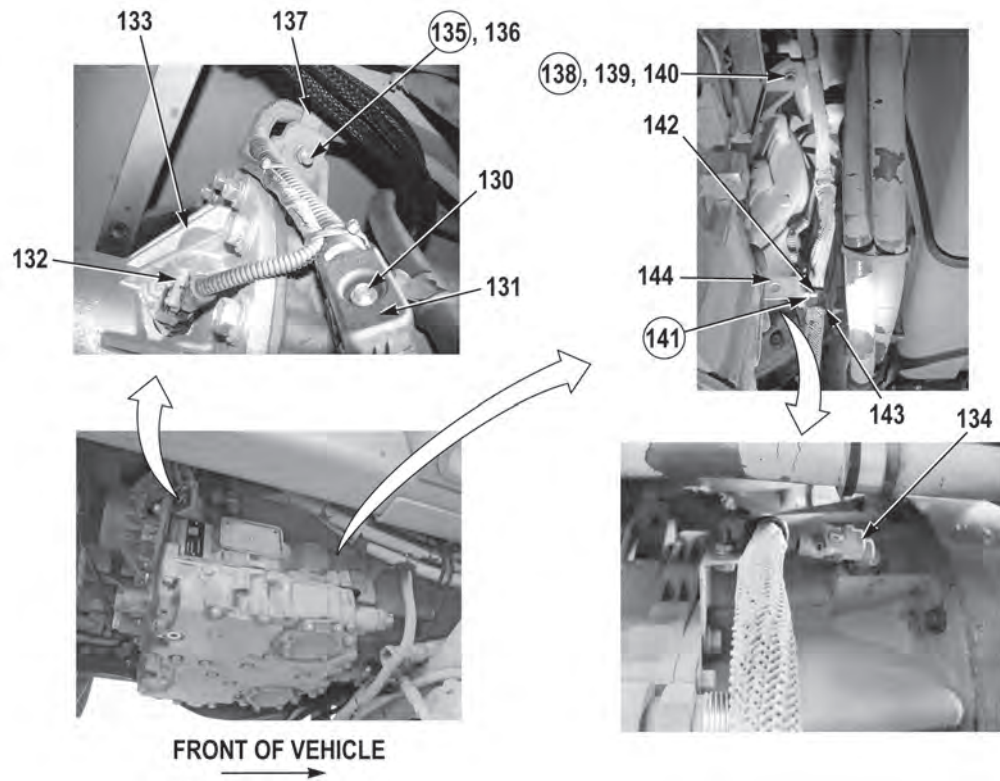

48. Loosen screw (130) and disconnect main connector (131).
49. Disconnect output connector (132) from transmission (133).
50. Disconnect input connector (134) from transmission (133).
51. Remove locknut (135), screw (136), and cushion clip (137) from transmission (133). Discard locknut (135).
52. Remove locknut (138), screw (139), and cushion clip (140) from transmission (133). Discard locknut (138).
53. Remove locknut (141), screw (142), and cushion clip (143) from bracket (144). Discard locknut (141).

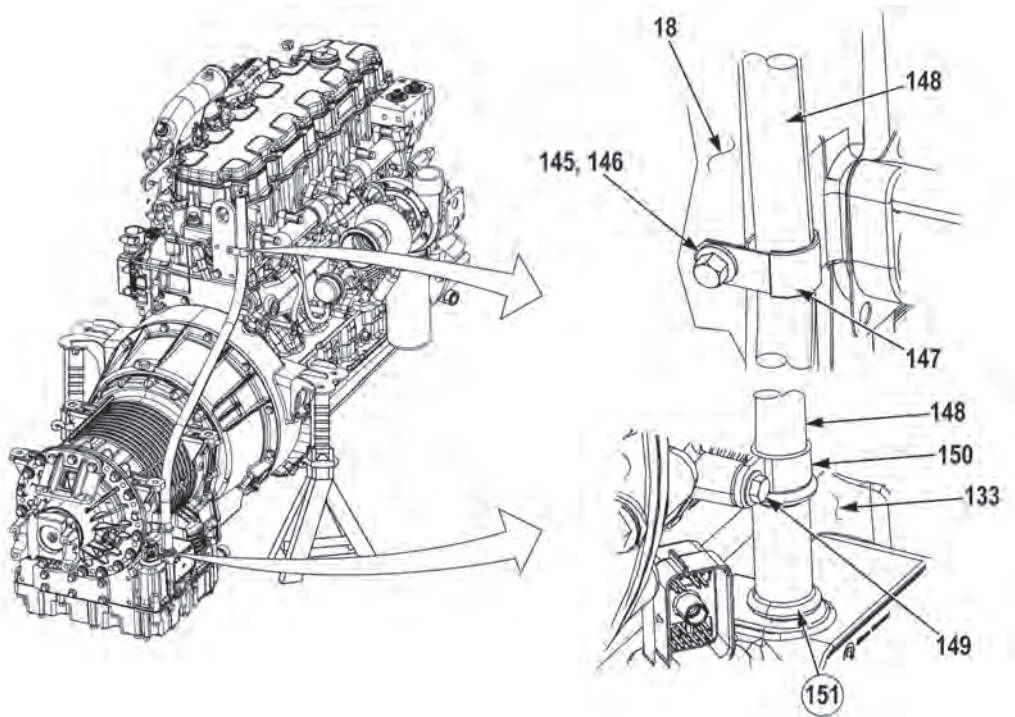

54. Remove screw (145), washer (146), cushion clip (147), and transmission dipstick tube (148) from engine (18).

### NOTE

Transmission dipstick tube is removed from bottom of transmission.

55. Remove screw (149), retaining band (150), transmission dipstick tube (148), and seal (151) from transmission (133). Discard seal (151).

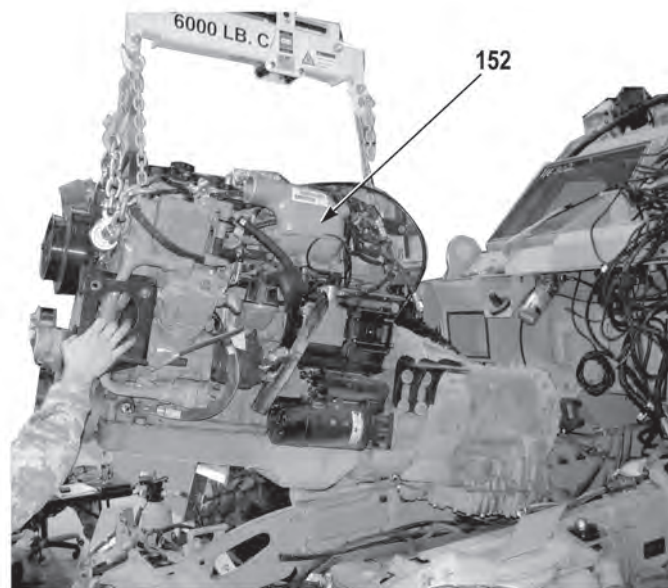

### **CAUTION**

- **Ensure all hoses, lines, harnesses, cables, and wires are not attached to powertrain. Failure to comply may result in damage to equipment.**
- **Powertrain must be removed carefully with a combination of forward and upward movements. Failure to comply may result in damage to equipment.**
- **Have an assistant monitor powertrain-to-chassis clearance during removal. Failure to comply may result in damage to equipment.**
- **After powertrain is lifted up, front rubber mounts and washers may need to be removed for oil pan clearance. Failure to comply may result in damage to equipment.**
- **Ensure cables and hoses are positioned above transmission during removal. Failure to comply may cause damage to equipment.**

### **NOTE**

- Remove cable ties as required.
- After powertrain is removed, six sets of rubber mounts may be replaced as required.

56. With the aid of two assistants and lifting device, remove powertrain (152) from vehicle.

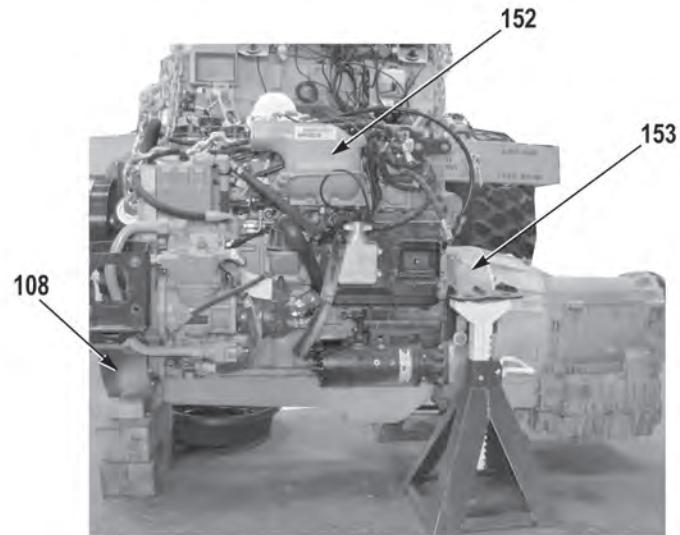

57. Lower powertrain (152) and position engine front support (108) on wooden blocks and position two mounting brackets (153) on two jackstands.

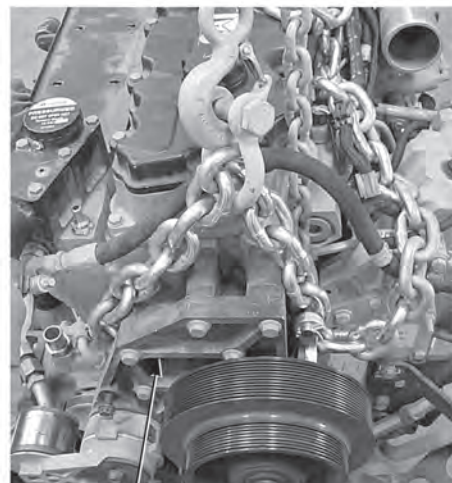

58. Remove lifting device from front accessory pulley bracket (104) and rear lift bracket (105).

**END OF TASK**

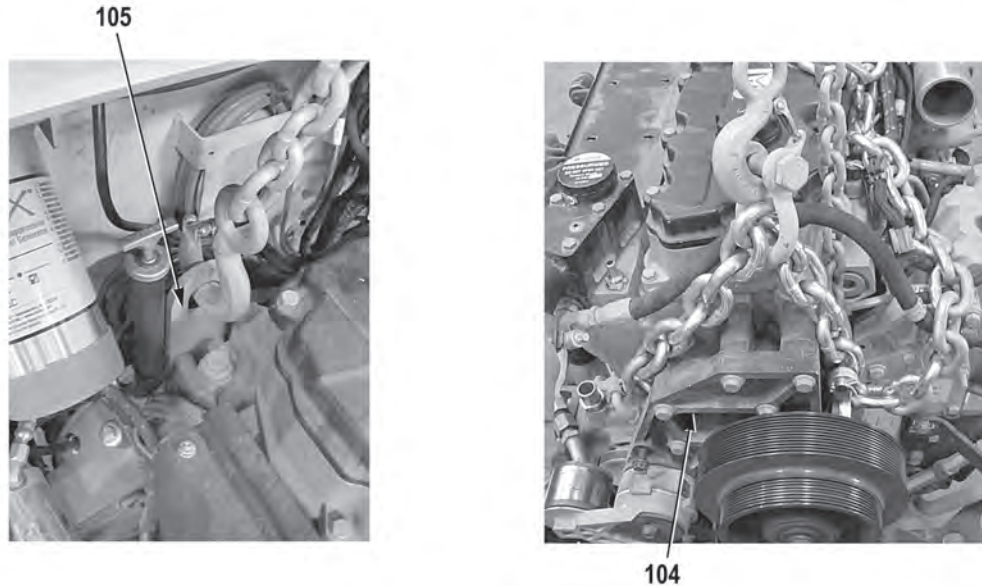
**INSTALLATION**

1. Attach lifting device to rear lift bracket (105), and front accessory pulley bracket (104).

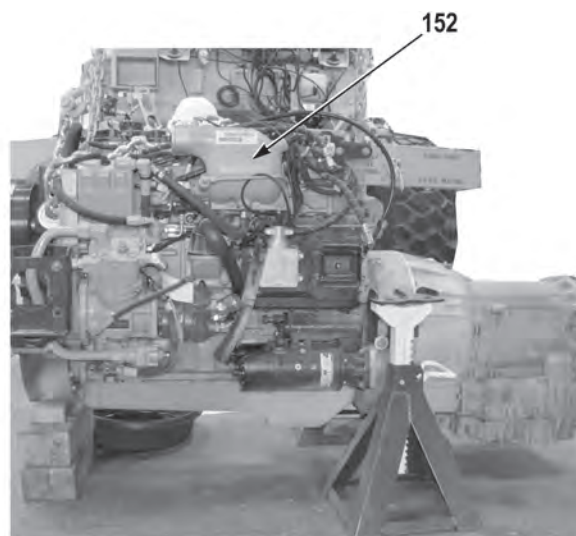
**WARNING**

**Powertrain weighs 2,300 lbs (1 044 kg). Do not attempt to lift or move powertrain without the aid of two assistants and lifting device. Failure to comply may result in injury or death to personnel.**

2. With the aid of two assistants and lifting device, remove powertrain (152) from wooden blocks and two jackstands.



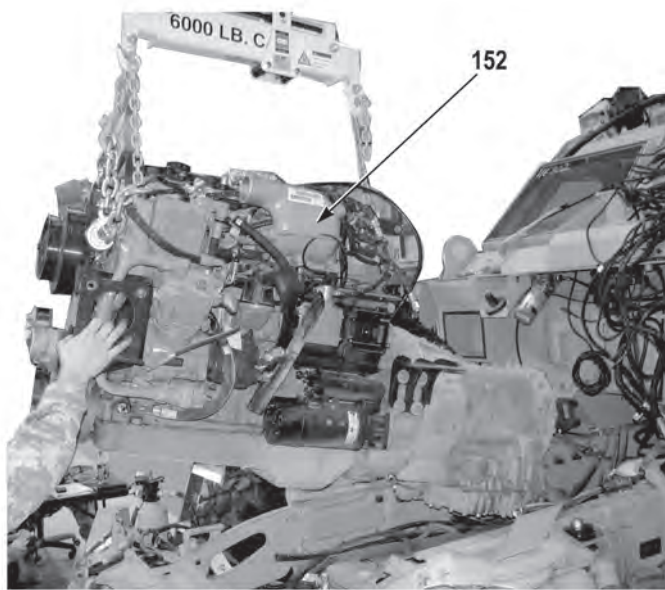

### **CAUTION**

- **Ensure all hoses, lines, harnesses, cables, and wires are clear of powertrain installation path. Failure to comply may result in damage to equipment.**
- **Powertrain must be installed carefully with a combination of downward and rearward movements. Failure to comply may result in damage to equipment.**
- **Have an assistant monitor powertrain-to-chassis clearance during installation. Failure to comply may result in damage to equipment.**
- **Front rubber mounts may need to remain uninstalled until oil pan has cleared front mounting position. Failure to comply may result in damage to equipment.**
- **Ensure cables and hoses are positioned above transmission during installation. Failure to comply may result in damage to equipment.**

### **NOTE**

- Ensure upper rubber mounts are in position prior to powertrain installation.
  - Allow lifting device to carry some weight of powertrain until mounting hardware can be installed.
  - Do not tighten mounting hardware until all mounting hardware is installed.
  - Note position of sling to prevent interference with firewall armor panel.
3. With the aid of two assistants and lifting device, position powertrain (152) on vehicle.

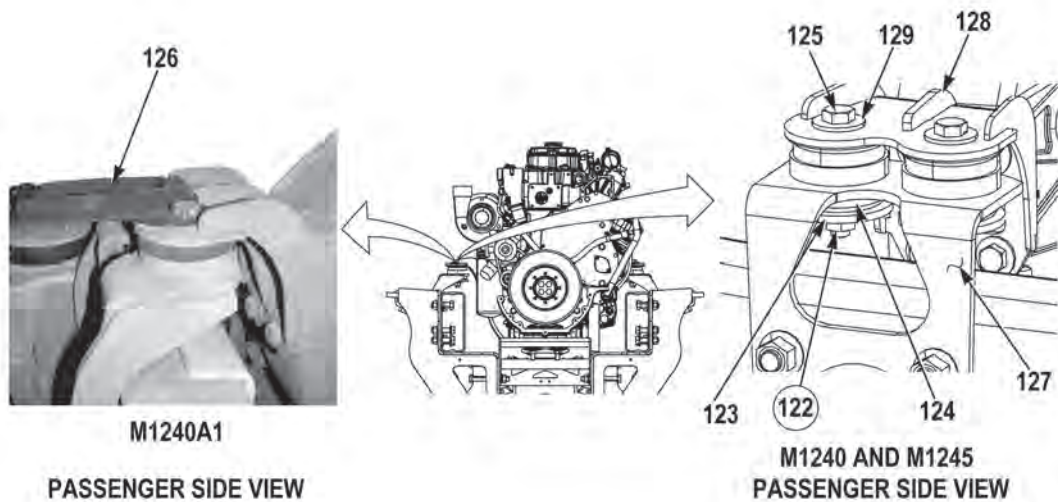

### NOTE

- Perform Step (4) for M1240A1 only.
  - Perform Step (5) for M1240 and M1245.
4. Install exhaust standoff bracket (126), two screws (125), lower rubber mounts (124), washers (123), and new locknuts (122) on mounting bracket (128) and passenger side frame bracket (127). Do not tighten locknuts.
  5. Install two washers (129), screws (125), lower rubber mounts (124), washers (123), and new locknuts (122) on mounting bracket (128) and passenger side frame bracket (127). Do not tighten locknuts.

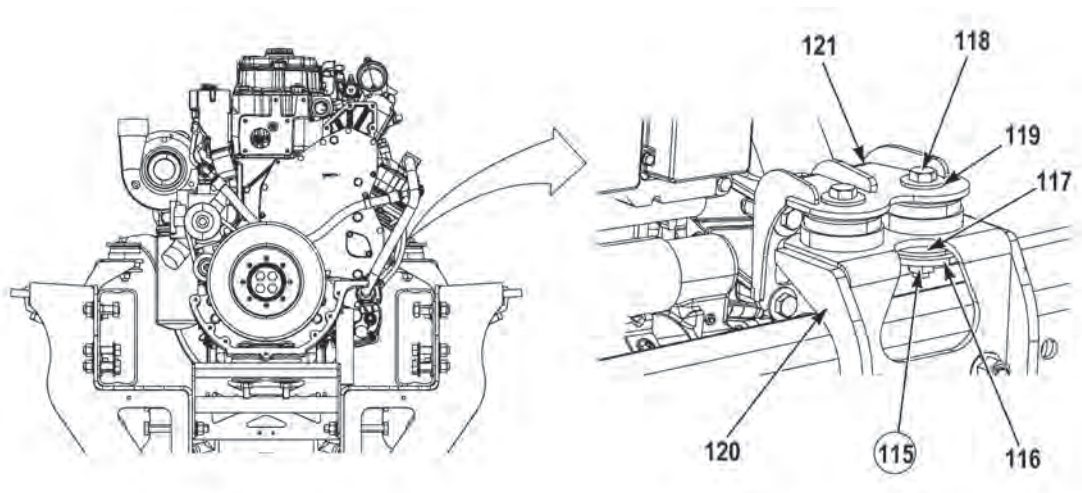

6. Install two washers (119), screws (118), lower rubber mounts (117), washers (116), and new locknuts (115) on mounting bracket (121) and driver side frame bracket (120). Do not tighten locknuts.



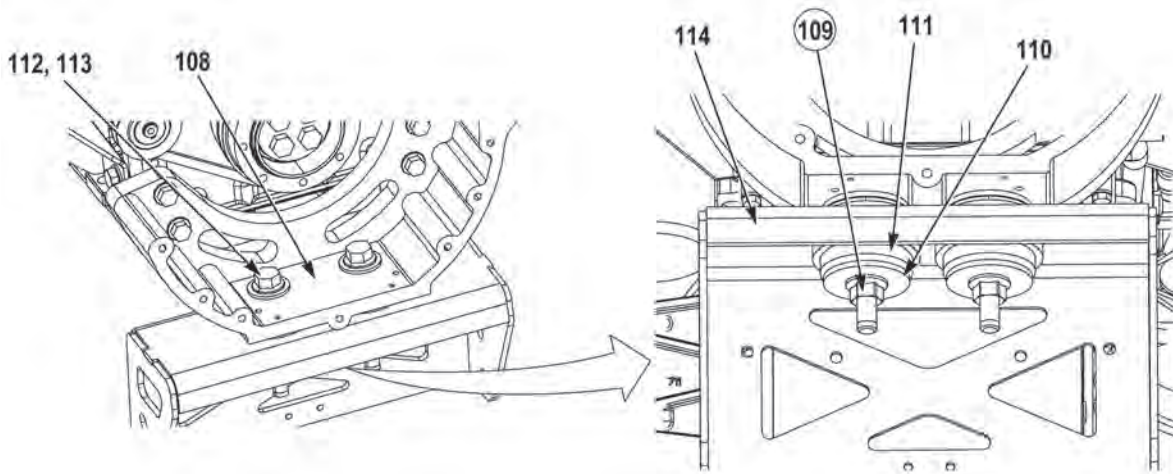

7. Install two washers (113), screws (112), lower rubber mounts (111), washers (110), and new locknuts (109) on engine front support (108) and crossover bracket (114). Do not tighten locknuts.
8. Install transmission spring support (WP 0234).
9. Tighten two locknuts (122), two locknuts (115), and two locknuts (109).

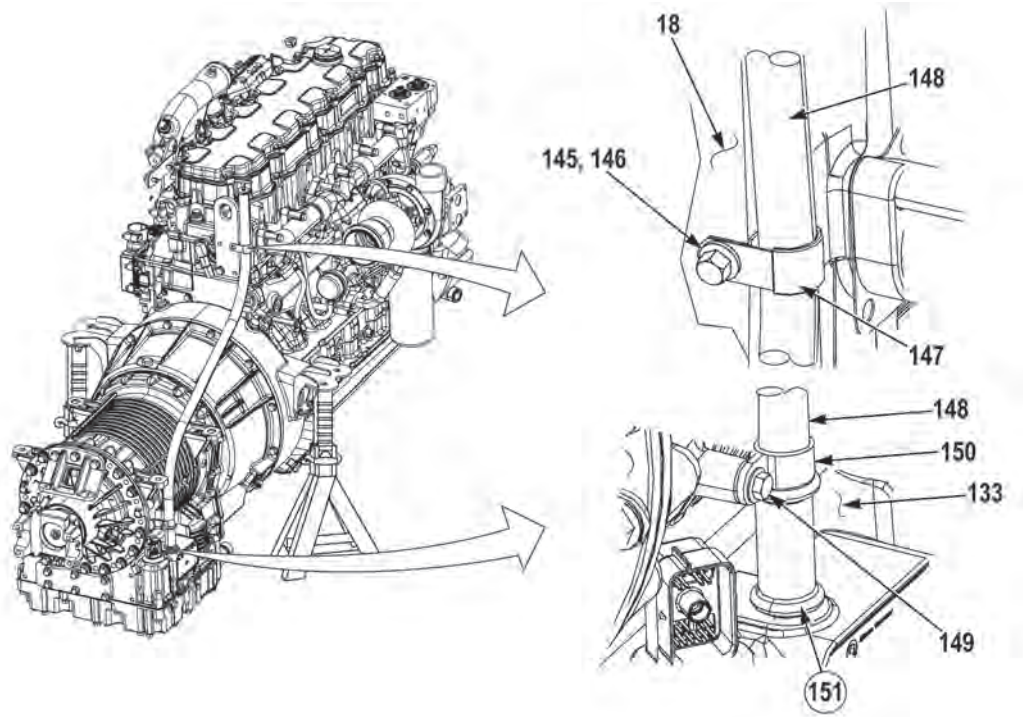

### NOTE

Transmission dipstick tube is installed from bottom of transmission.

10. Install new seal (151), retaining band (150), and transmission dipstick tube (148) on transmission (133) with screw (149).
11. Install transmission dipstick tube (148) on engine (18) with cushion clip (147), washer (146), and screw (145).

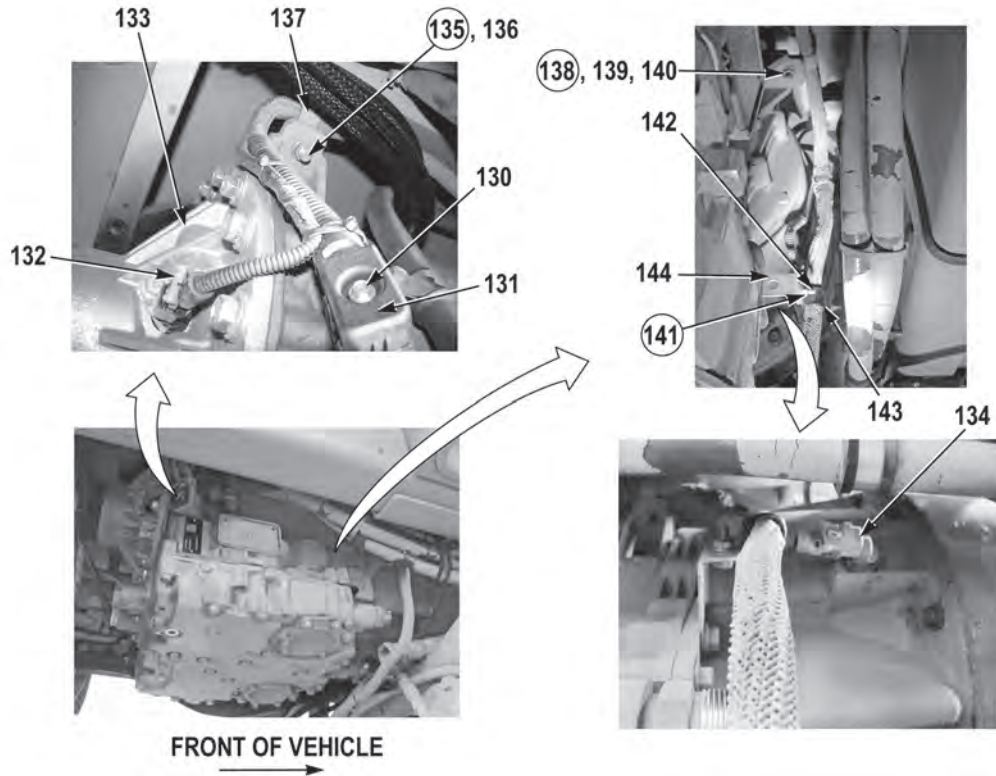

12. Install cushion clip (143) on bracket (144) with screw (142) and new locknut (141).
13. Install cushion clip (140) on transmission (133) with screw (139) and new locknut (138).
14. Install cushion clip (137) on transmission (133) with screw (136) and new locknut (135).
15. Connect input connector (134) to transmission (133).
16. Connect output connector (132) to transmission (133).
17. Connect connector (131) and tighten screw (130).

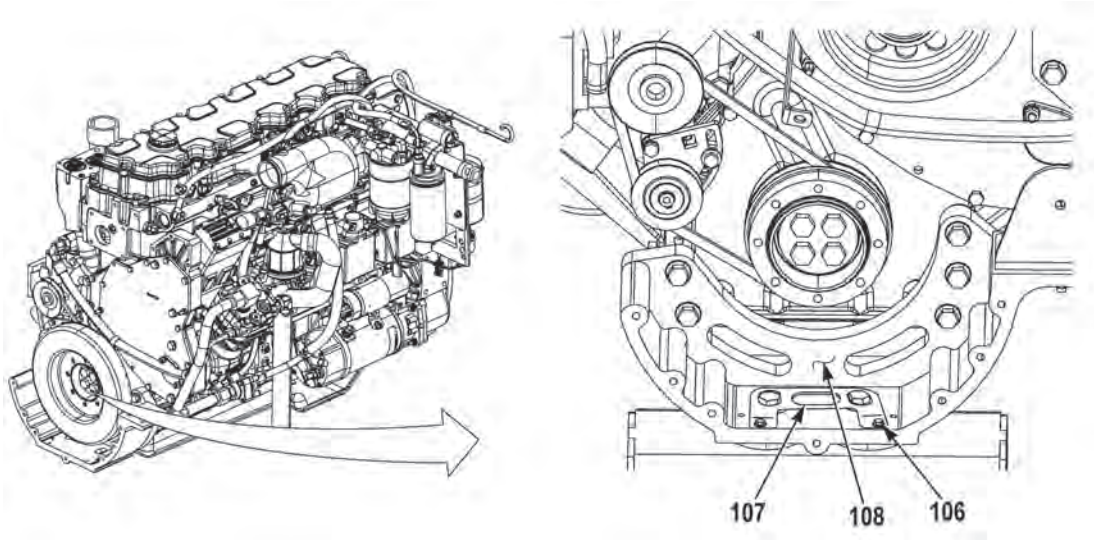

18. Install retainer plate (107) on engine front support (108) with two screws (106).

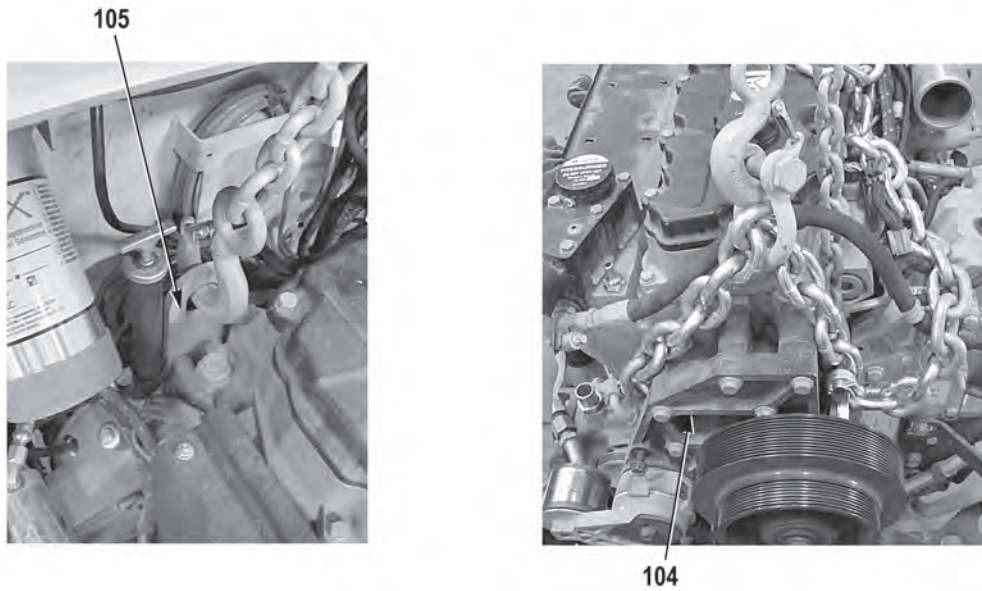

19. Remove lifting device from rear lift bracket (105) and front accessory pulley bracket (104).



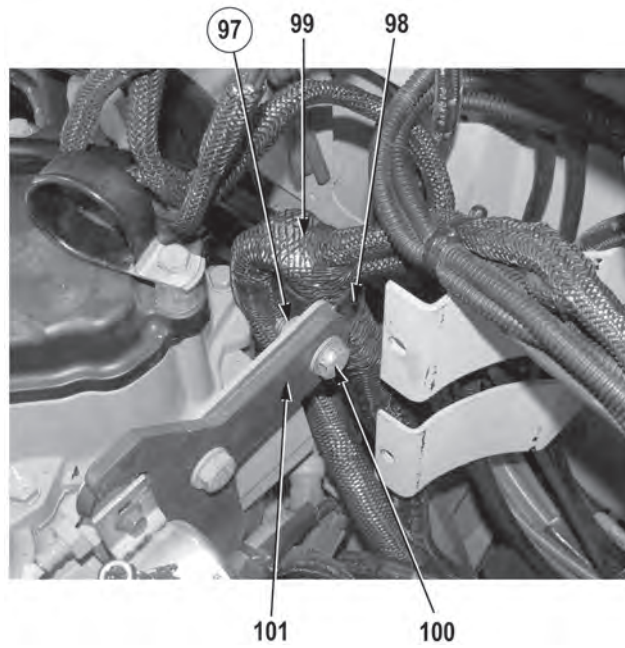

20. Install engine harness (99) and cushion clip (98) on bracket (101) with screw (100) and locknut (97).

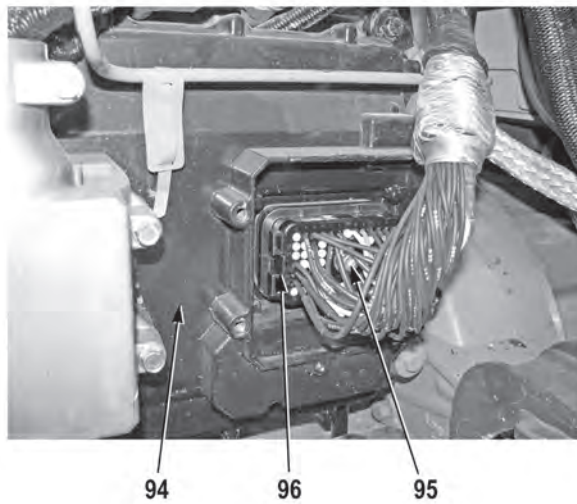

21. Connect connector (96) to engine control unit (94) and tighten screw (95).

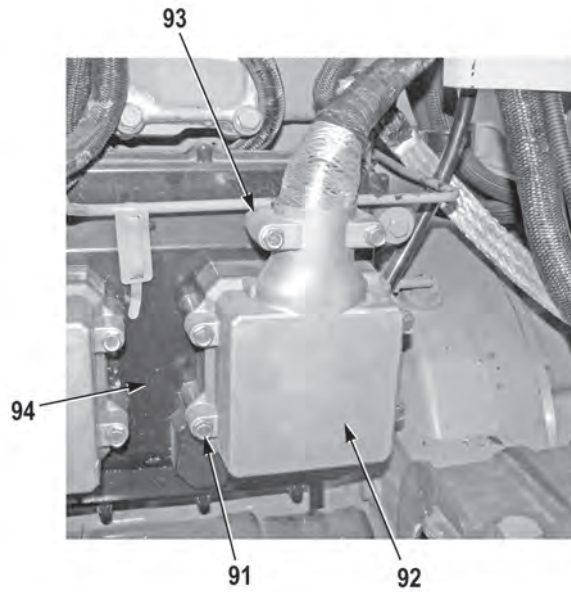
**NOTE**

Install retainer and two screws prior to mounting cover on engine.

22. Install cover (92) and retainer (93) on engine control unit (94) with six screws (91).

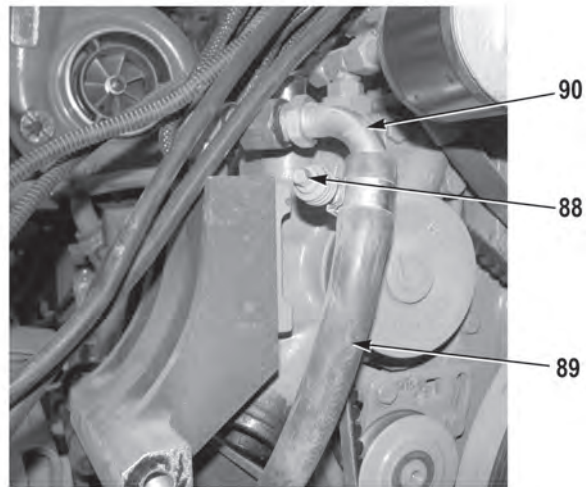

23. Install hose (89) on fitting (90) with clamp (88).

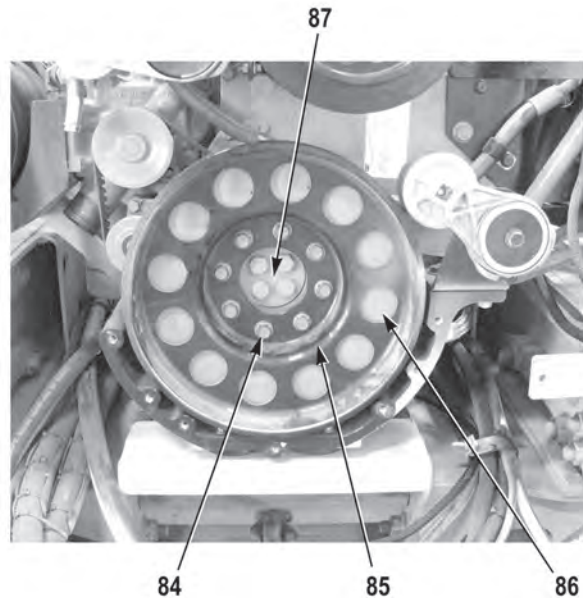

### **WARNING**

Adhesives, solvents, and sealing compounds can burn easily, can give off harmful vapors, and are harmful to skin and clothing. To avoid injury or death, keep away from open fire and use in well-ventilated area. If adhesive, solvent, or sealing compound gets on skin or clothing, wash immediately with soap and water. Failure to comply may result in injury or death to personnel.

### **CAUTION**

Tighten screws in a crisscross pattern. Failure to comply may result in damage to equipment.

24. Apply sealing compound, Loctite 242, to threads of eight screws (84) and install vibration damper (86) and crankshaft pulley (85) on crankshaft adapter (87) with screws (84).

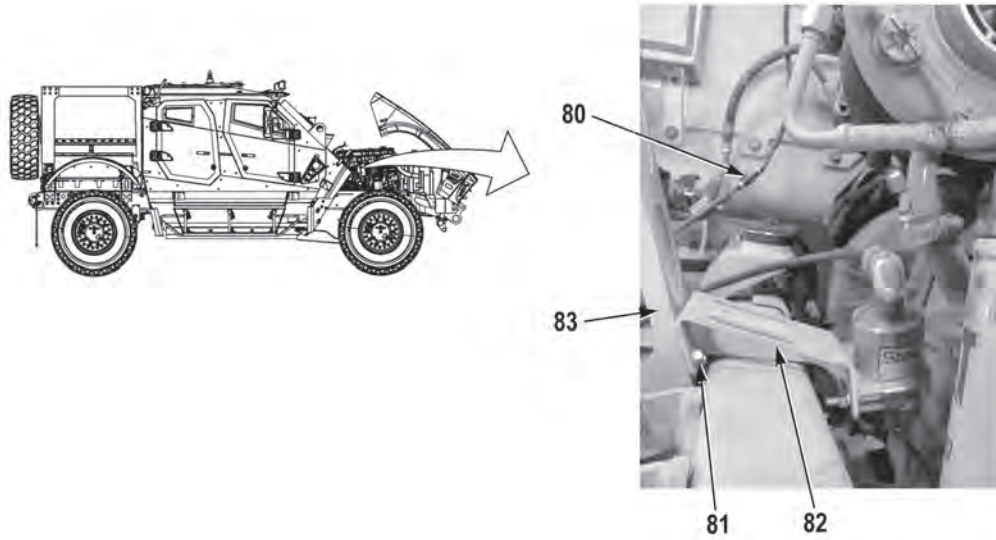

**NOTE**

Perform Steps (25) and (26) if equipped with five generator system.

25. Install bracket (82) on bracket (83) with two screws (81).

**NOTE**

Install cable ties as required.

26. Connect connector (80).

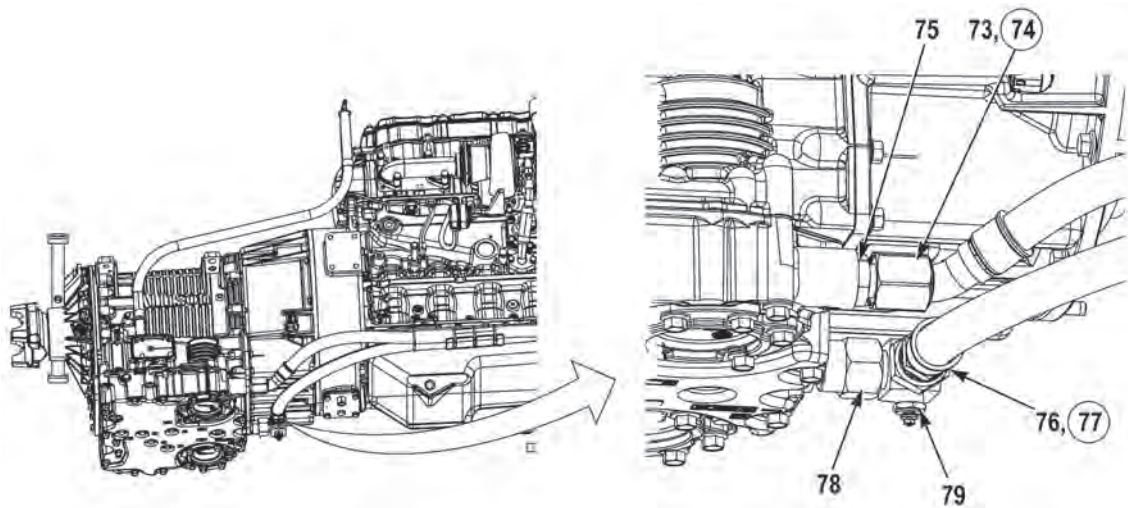

### **WARNING**

**Adhesives, solvents, and sealing compounds can burn easily, can give off harmful vapors, and are harmful to skin and clothing. To avoid injury or death keep away from open flame and use in well-ventilated area. If adhesive, solvent, or sealing compound gets on skin or clothing, wash immediately with soap and water. Failure to comply may result in injury or death to personnel.**

27. Apply sealing compound, Loctite 567, to threads of transmission oil temperature sending unit (79), and install transmission oil temperature sending unit (79) on fitting (78).
28. Lightly lubricate new O-ring (77) with clean oil and install new O-ring (77) and hose (76) on fitting (78).
29. Lightly lubricate new O-ring (74) with clean oil and install new O-ring (74) and hose (73) on fitting (75).

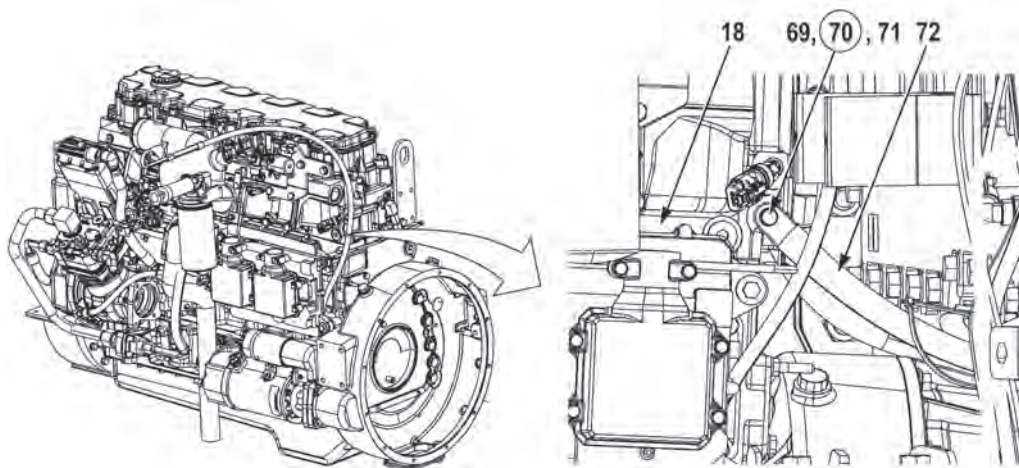

### **NOTE**

Ensure mating surface of engine and rear ground strap is clean bare metal prior to installation.

30. Install rear ground strap (72) on engine (18) with washer (71), new lockwasher (70), and screw (69).

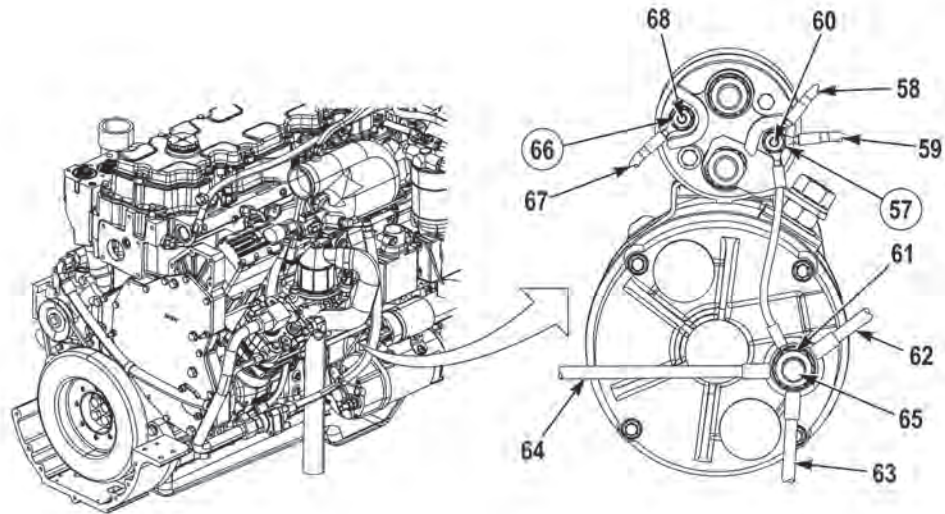

31. Install wire (67) on stud (68) with new locknut (66). Tighten new locknut (66) to 30 to 40 lb-in (3.4 to 4.5 N·m).

#### NOTE

Nut was reinstalled to retain ground wire. Remove nut prior to installing remaining ground cables.

32. Install cable (64), cable (63), and cable (62) on starter ground stud (65) with nut (61). Tighten nut (61) to 29 to 31 lb-ft (39 to 42 N·m).

#### NOTE

Locknut was reinstalled to retain ground wire. Remove locknut prior to installing wire, discard, and replace with new locknut.

33. Install wire (59) and wire (58) on stud (60) with new locknut (57). Tighten new locknut (57) to 30 to 40 lb-in (3.4 to 4.5 N·m).

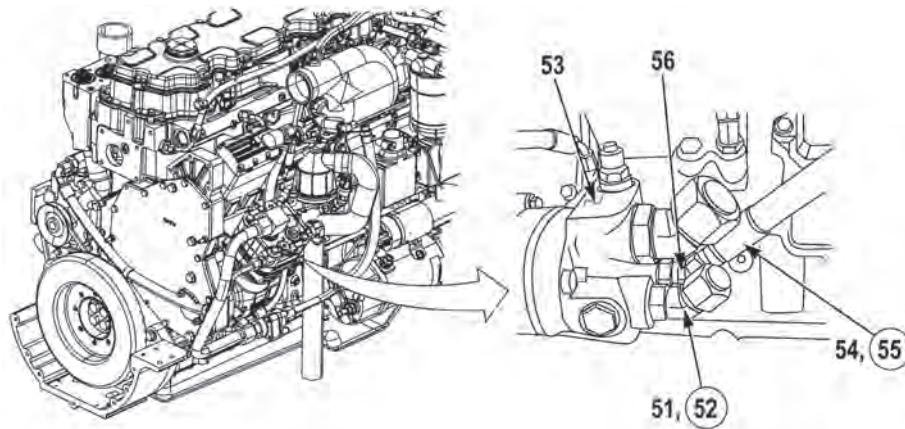
**NOTE**

- Note position and orientation of fittings prior to removal to ensure proper installation.
- Fitting must be removed to aid in installation of inboard hose on power steering pump.

34. Remove fitting (51) and O-ring (52) from power steering pump (53). Discard O-ring (52).
35. Lightly lubricate new O-ring (55) with clean oil and install new O-ring (55) and hose (54) on fitting (56).

**NOTE**

Install fitting as noted prior to removal.

36. Lightly lubricate new O-ring (52) with clean oil and install new O-ring (52) and fitting (51) on power steering pump (53).

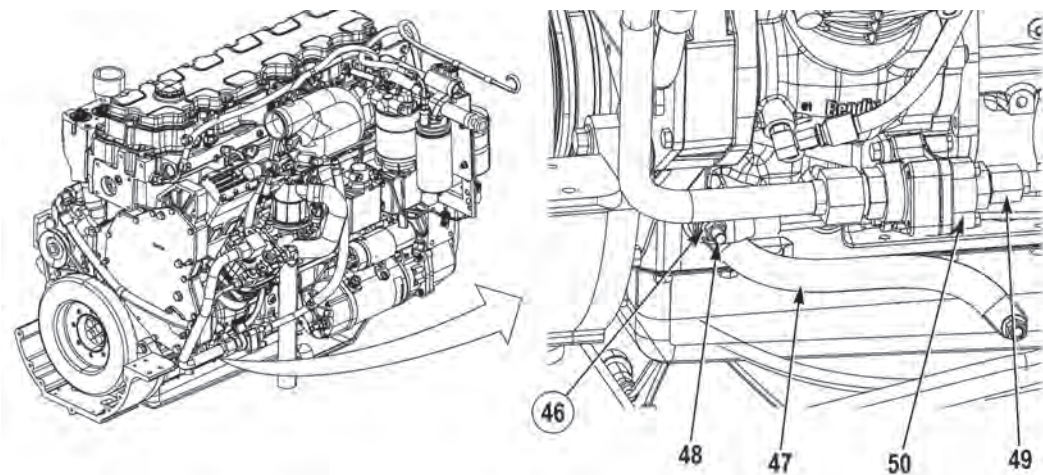

37. Install air compressor inlet tube (49) on check valve (50).

**NOTE**

Ensure mating surface of ground stud and forward ground strap is clean bare metal prior to installation.

38. Install forward ground strap (47) on ground stud (48) with new locknut (46).

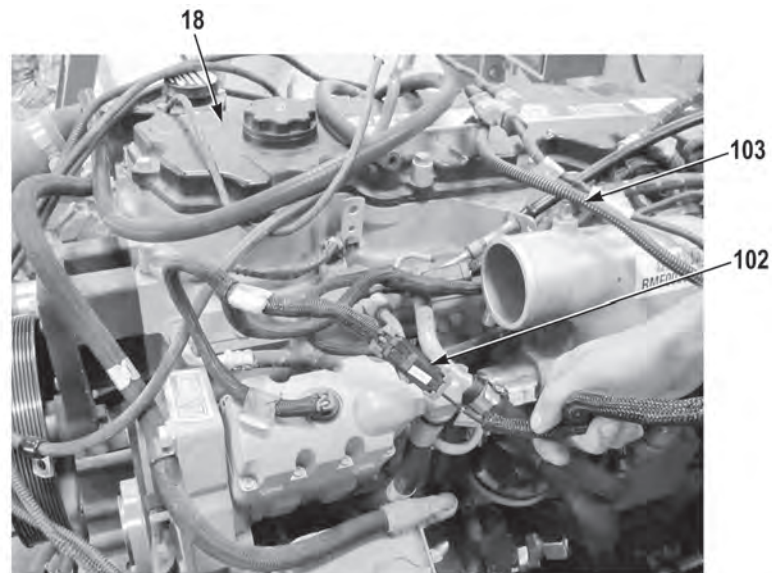

**NOTE**

Route wires and harnesses as noted prior to removal.

39. Position wires and harnesses (103) on top of engine (18).
40. Connect connector (102).

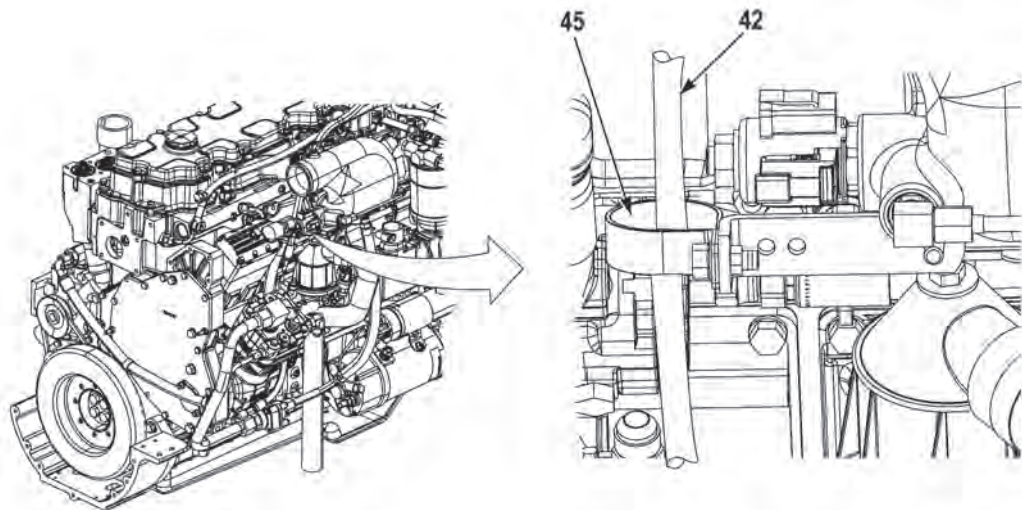
**NOTE**

Route cable as noted prior to removal.

41. Route cable (42) through cushion clip (45).

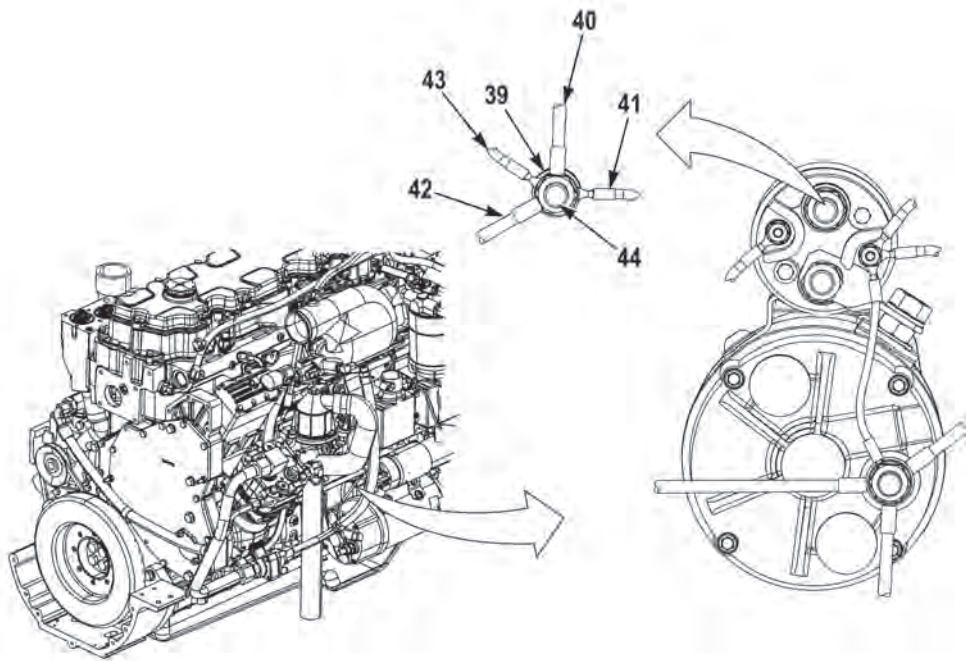
**NOTE**

Ensure crankcase breather is routed as shown.

42. Install wire (43), cable (42), cable (41), and cable (40) on stud (44) with nut (39). Tighten nut (39) to 29 to 31 lb-ft (39 to 42 N·m).



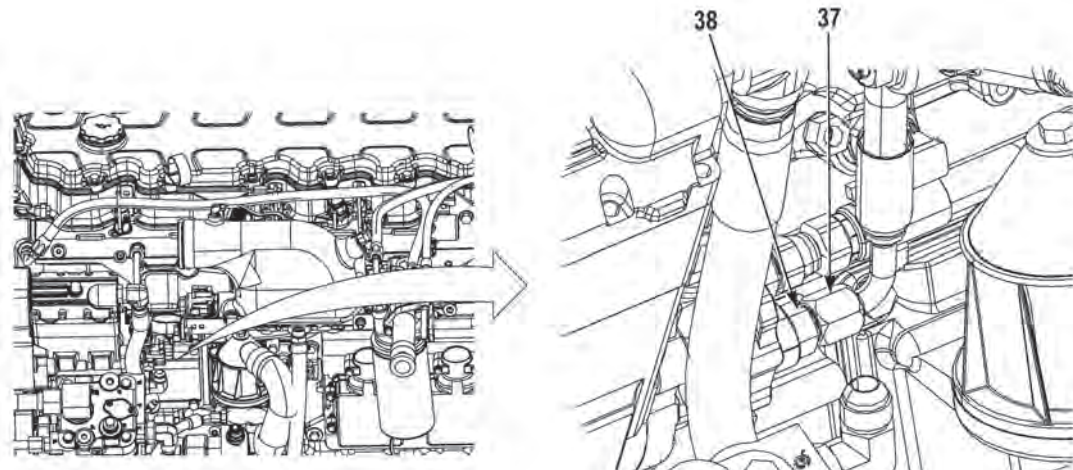

### **WARNING**

Fuel is flammable and can explode. Keep fuel away from open flame and keep fire extinguisher within easy reach when working with fuel. Do not work on fuel system when engine is hot. Fuel can be ignited by hot engine. Smoking is prohibited while working with fuel. Failure to comply may result in injury or death to personnel.

### **NOTE**

Perform Step (43) if hose (37) was removed.

43. Install hose (37) on fitting (38).

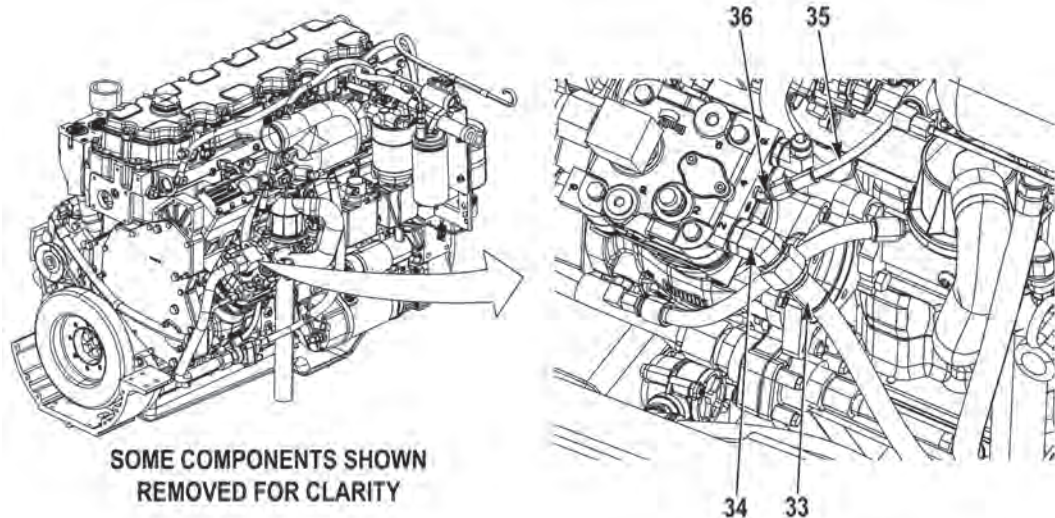

44. Install air line (35) on fitting (36).

### **NOTE**

Fitting (34) may be a 90 instead of a 45 degree fitting.

45. Install air line (33) on fitting (34).

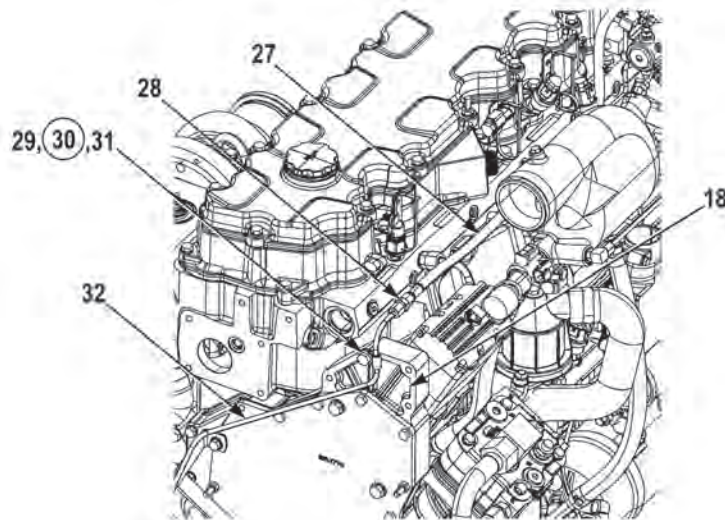

46. Install air line tube (32) on engine (18) with cushion clip (31), new lockwasher (30) and screw (29).
47. Install air line (27) on fitting (28).

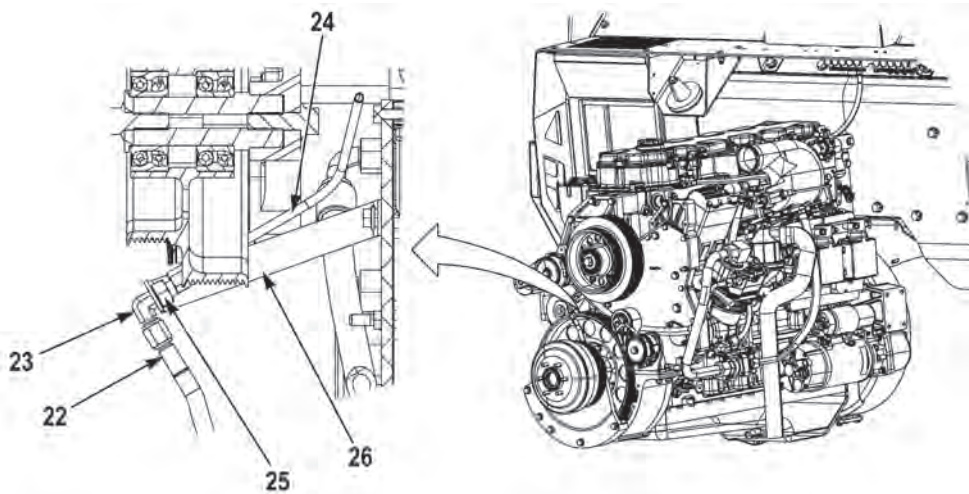

### NOTE

Install fitting as noted prior to removal.

48. Install fitting (23) on standoff bracket (26) with nut (25).
49. Install air line tube (24) on fitting (23).
50. Install air line (22) on fitting (23).

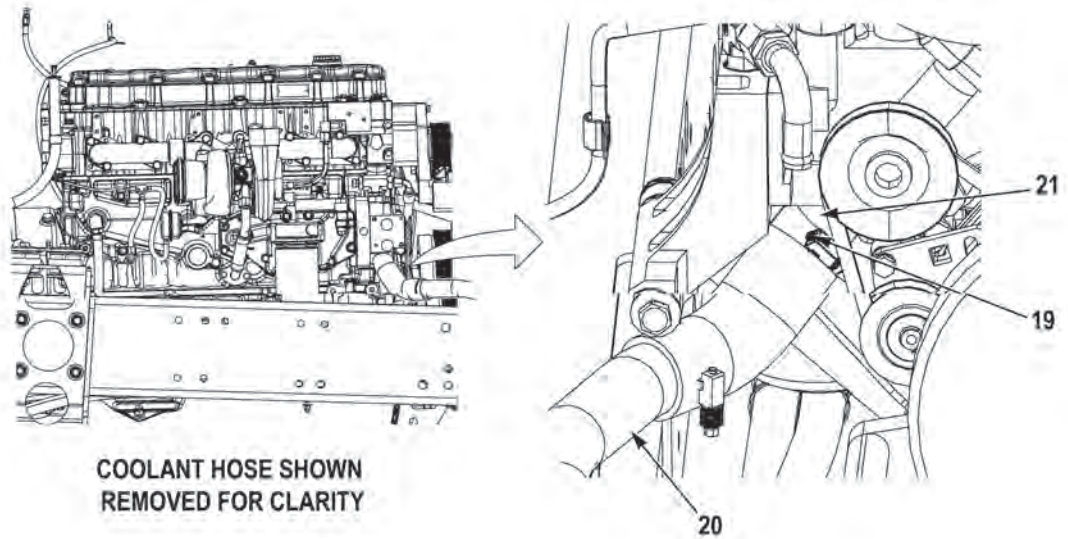

51. Install front heater hose (20) on fitting (21) with clamp (19). Tighten clamp (19) to 40 lb-in (4.5 N-m).

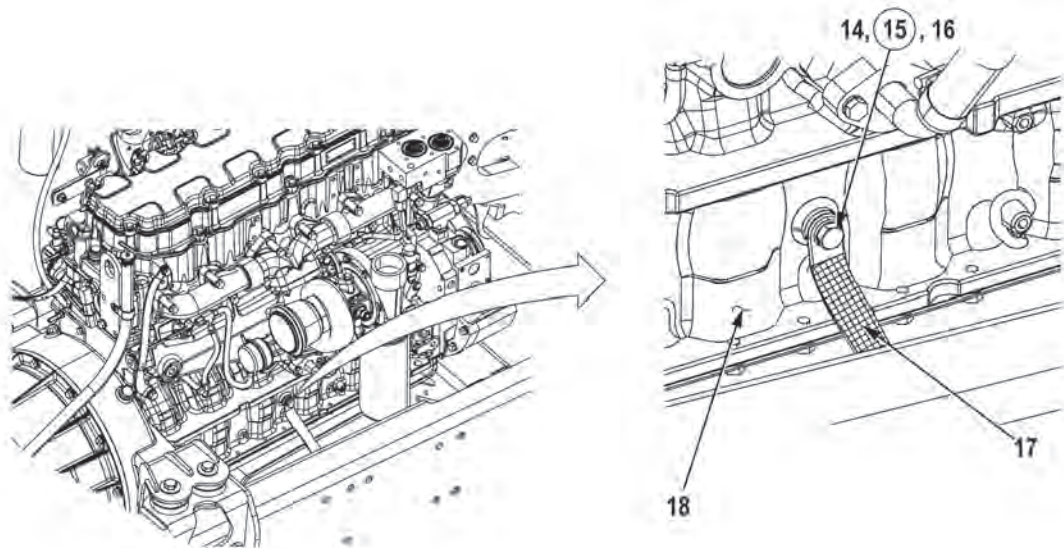

### NOTE

Ensure mating surface of engine and passenger side ground strap is clean bare metal prior to installation.

52. Install passenger side ground strap (17) on engine (18) with washer (16), new lockwasher (15), and screw (14).



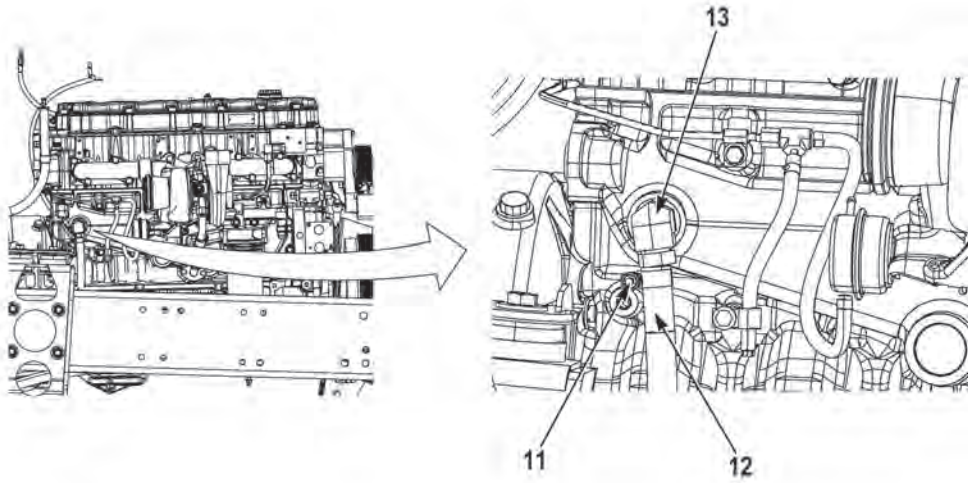

53. Install rear heater hose (12) on fitting (13) with clamp (11). Tighten clamp (11) to 40 lb-in (4.5 N·m).

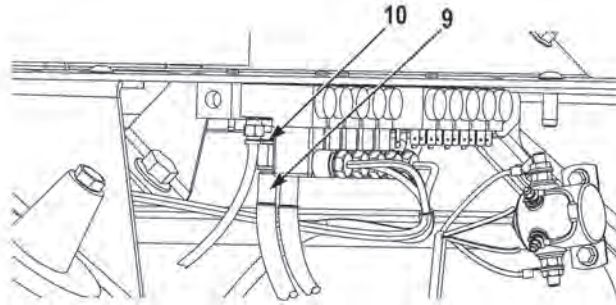

54. Install air line (9) on fitting (10).

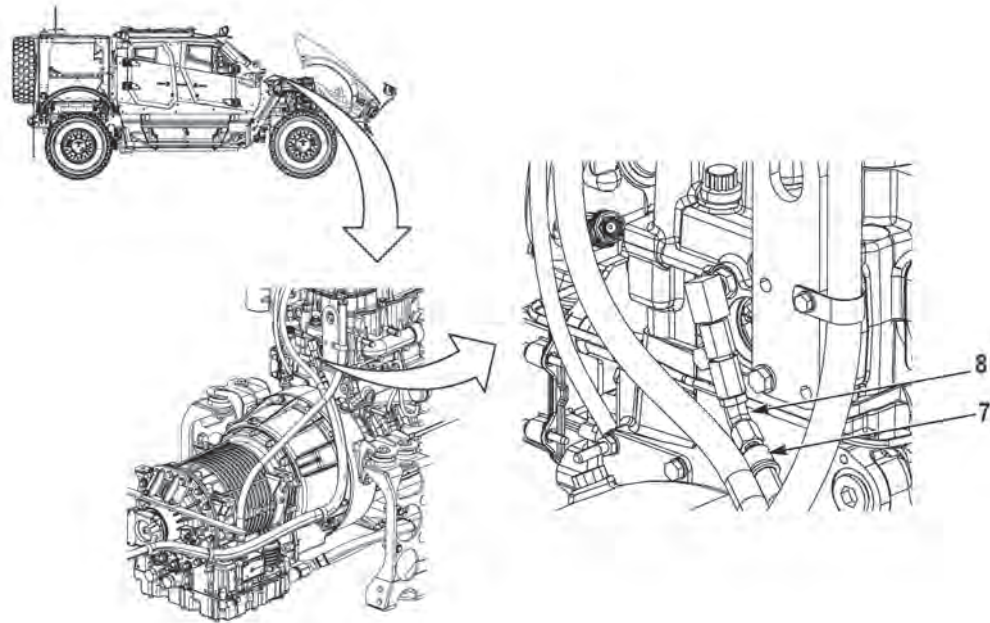

**WARNING**

Fuel is flammable and can explode. Keep fuel away from open flame and keep fire extinguisher within easy reach when working with fuel. Do not work on fuel system when engine is hot. Fuel can be ignited by hot engine. Smoking is prohibited while working with fuel. Failure to comply may result in injury or death to personnel.

55. Install fuel return hose (7) on fitting (8).

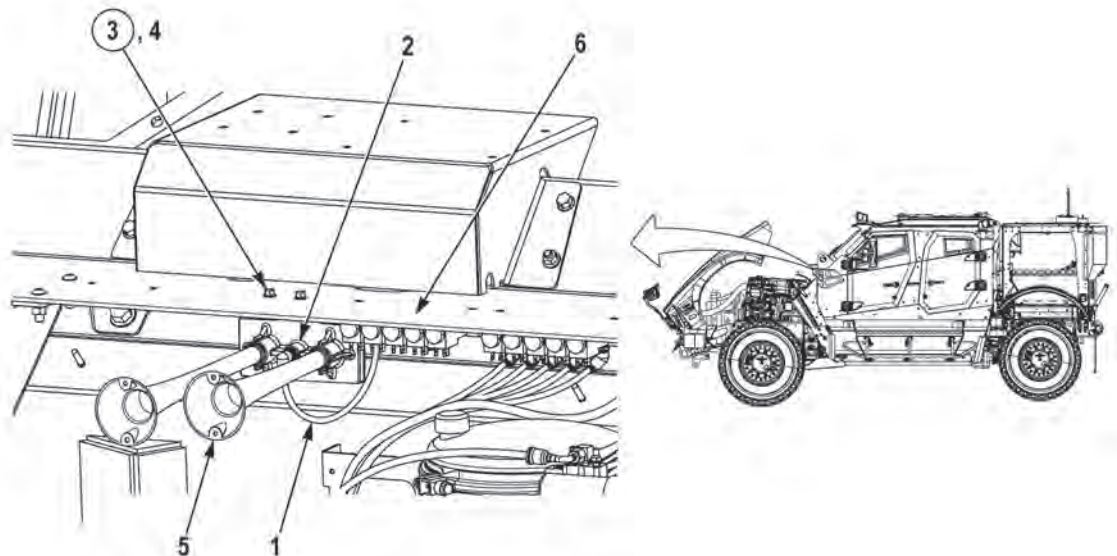

56. Install air horn (5) on hood support (6) with two screws (4) and new locknuts (3).

57. Install air line (1) on fitting (2).

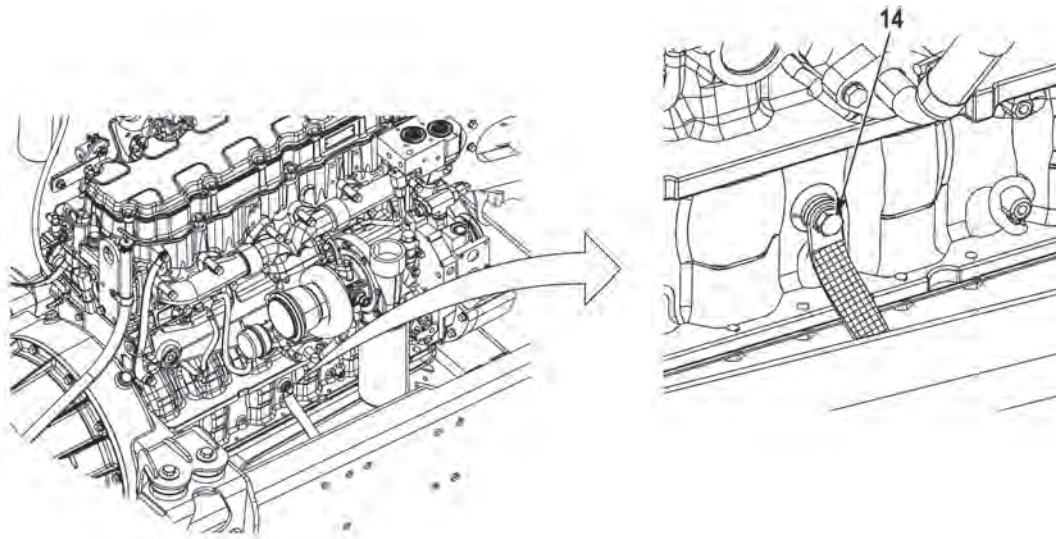

### **WARNING**

Adhesives, solvents, and sealing compounds can burn easily, can give off harmful vapors, and are harmful to skin and clothing. To avoid injury or death, keep away from open fire and use in well-ventilated area. If adhesive, solvent, or sealing compound gets on skin or clothing, wash immediately with soap and water. Failure to comply may result in injury or death to personnel.

### **NOTE**

When applying sealing compound, RTV, to connections, ensure heads of screws, studs, and bare terminals are covered.

58. Apply sealing compound, RTV, to head of screw (14).

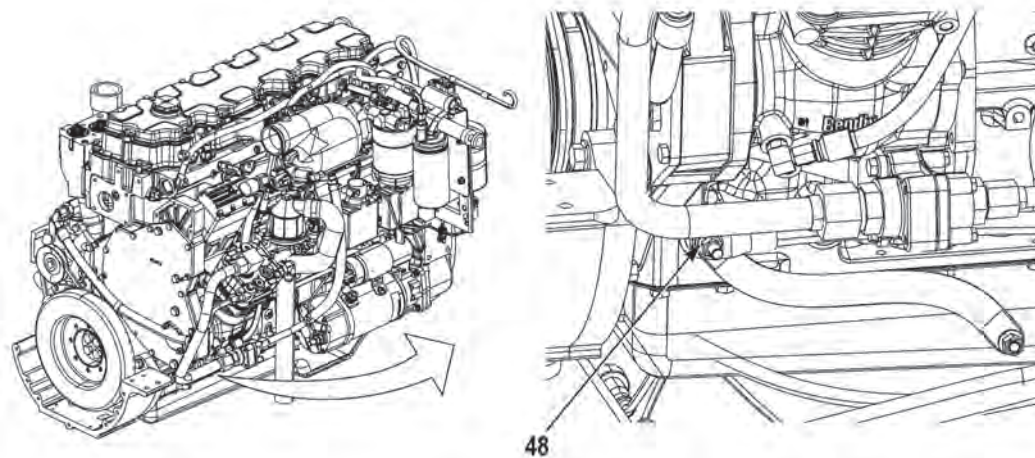

59. Apply sealing compound, RTV, to ground stud (48).



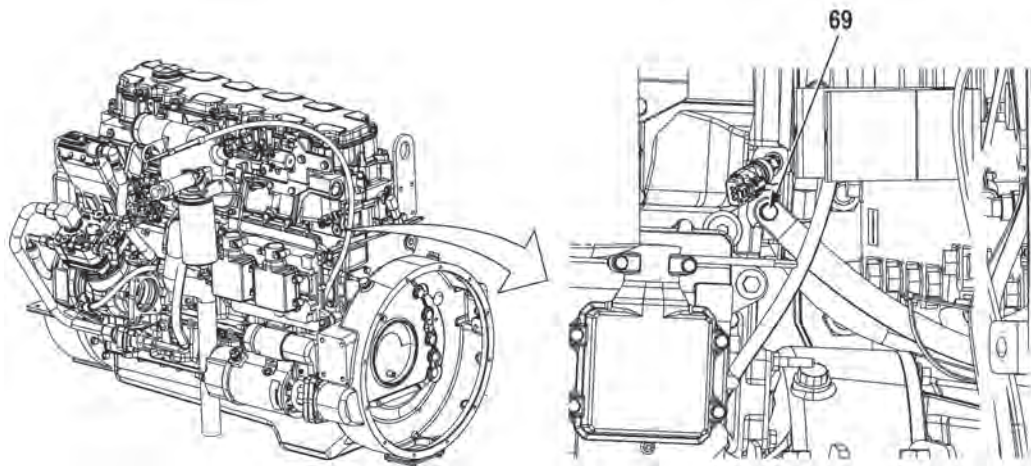

### **WARNING**

Adhesives, solvents, and sealing compounds can burn easily, can give off harmful vapors, and are harmful to skin and clothing. To avoid injury or death, keep away from open fire and use in well-ventilated area. If adhesive, solvent, or sealing compound gets on skin or clothing, wash immediately with soap and water. Failure to comply may result in injury or death to personnel.

60. Apply sealing compound, RTV, to head of screw (69).

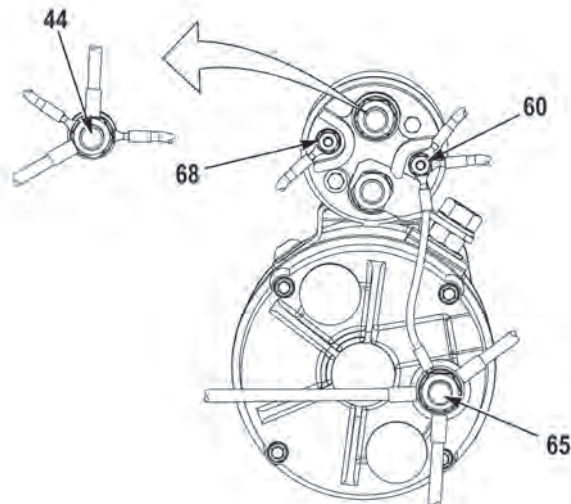

61. Apply sealing compound, RTV, to stud (44), stud (60), starter ground stud (65), and stud (68).
62. Install propeller shaft (propeller shaft from transmission to transfer case) on transmission yoke (WP 0090).
63. Install passenger side belly deflector panel, center belly deflector panel, ladder panel, and underbody improvement panel (WP 0056).

**CAUTION**

**Ensure engine is full of oil prior to starting engine. Failure to comply may result in damage to equipment.**

**NOTE**

Do not install front passenger side wheel well deflector panel when performing Follow-On Maintenance. Wheel well deflector panel is left off to gain access to and visibility of transmission lines for leak checks.

64. Perform all Follow-On Maintenance tasks.

**NOTE**

When checking engine for leaks pay particular attention to transmission fluid lines, coolant lines, fuel lines, engine oil lines, and power steering lines.

65. Start engine and check engine for any leaks.  
66. Check transmission fluid level and adjust as necessary (WP 0232).  
67. Shut off engine (TM 9-2355-335-10).  
68. Check engine oil level and adjust as necessary (WP 0224).

**WARNING**

**During normal vehicle operation, cooling system can become very hot. Allow cooling system to cool prior to servicing cooling system. Failure to comply may result in injury or death to personnel.**

**NOTE**

- Perform Step (69) if vehicle has a coolant reservoir.
- Perform Step (70) if vehicle has a coolant surge tank.

69. Check coolant level and adjust as necessary (WP 0176).  
70. Check coolant level and adjust as necessary (WP 0177).  
71. Check power steering fluid level and adjust as necessary (WP 0278).

**NOTE**

- Perform Step (72) for M11240/M1245.
- Perform Step (73) for M1240A1.

72. Install front passenger side Wheel Well Deflector Panel (WP 0059).  
73. Install front passenger side Wheel Well Deflector Panel (WP 0057).  
74. Perform PMCS (TM 9-2355-335-10).

**END OF TASK**

**END OF WORK PACKAGE**

---

**ENGINE/TRANSMISSION ASSEMBLY/DISASSEMBLY**

---

**Preconditions**

Vehicle parked  
 Engine OFF  
 Wheels chocked  
 Powertrain removed (WP 0227)

**Tools and Special Tools**

Bracket, Transmission Holding  
 Bracket, Transmission Lifting  
 Breaker Bar, 3/4"  
 Lifting Device, Minimum Capacity 1,000 lbs  
 (454 kg)  
 Locknut (4 required)  
 Screw (4 required)  
 Socket, Turning Tool, Engine  
 Tool Kit, General Mechanic's: Automotive  
 Wrench, Torque, 20 to 100 ft-lb

**Materials/Parts**

Compound, Sealing, Loctite 242  
 Oil, Lubricating  
 Seal (Item 16)  
 Gasket (Item 22)  
 Locknut (4) (Item 20)

**Personnel Required:**

Maintainer (2)

**Follow-On Maintenance**

Install powertrain (WP 0227)

---

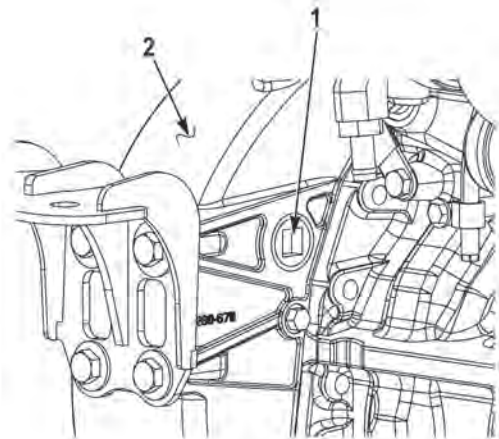
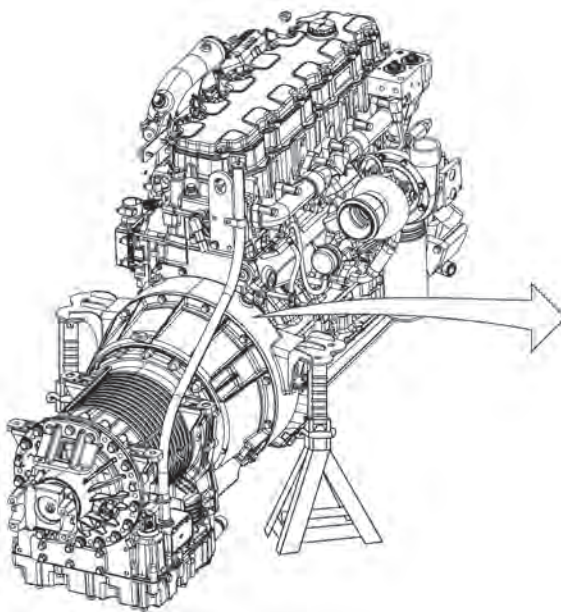
**ENGINE/TRANSMISSION DISASSEMBLY**

1. Remove plug (1) from flywheel housing (2).

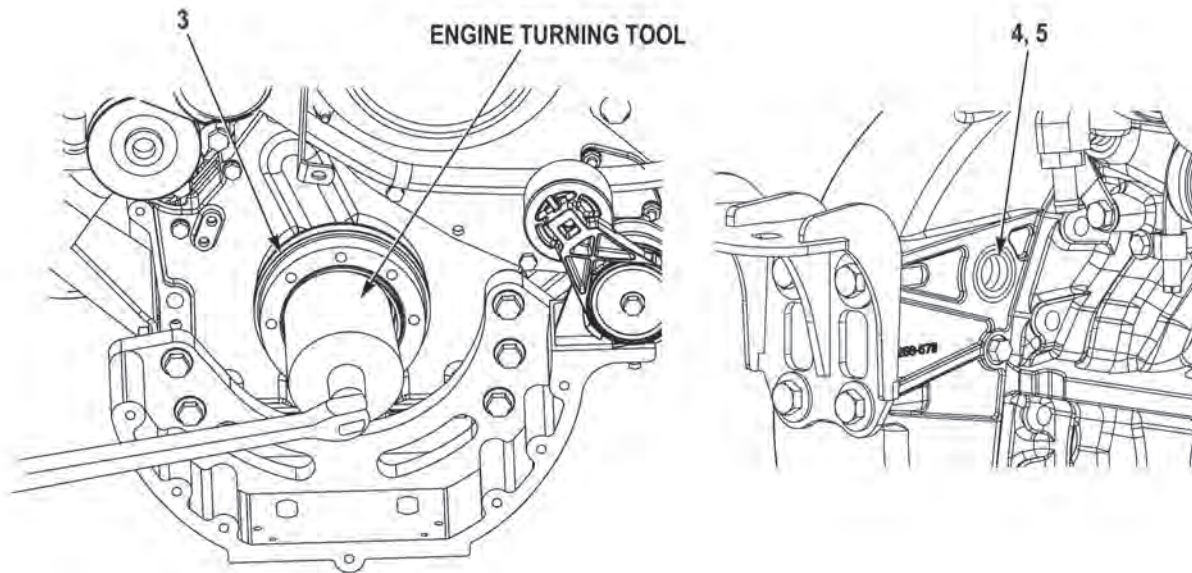

2. Using engine turning tool socket placed on crankshaft adapter (3) and the aid of an assistant, rotate crankshaft adapter (3) while assistant notes when flexplate attach screw (4) becomes visible in hole on flywheel housing (5).

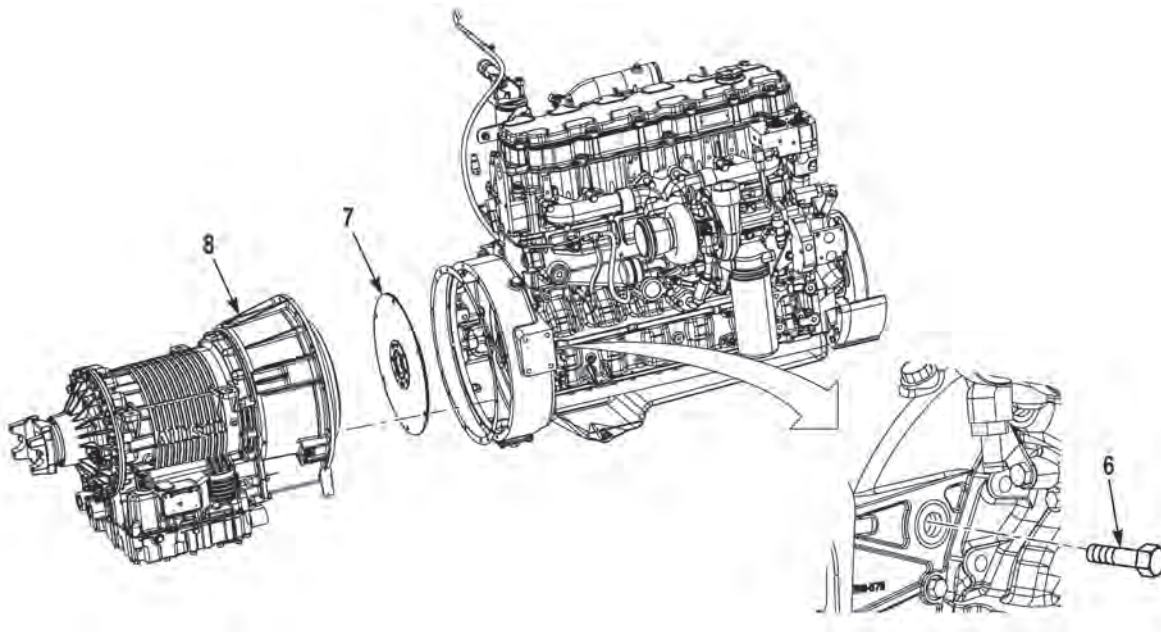

3. Remove screw (6) from flexplate (7) and transmission (8).
4. Repeat Steps (2) and (3) for remaining five flexplate attach screws (6).



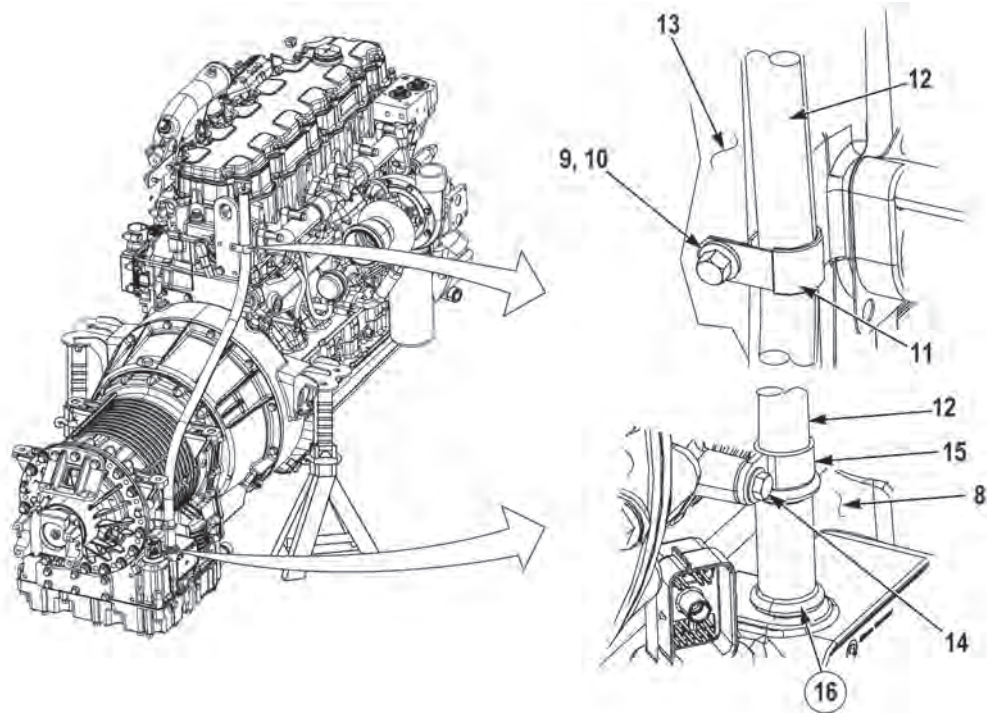

5. Remove screw (9), washer (10), cushion clip (11), and transmission dipstick tube (12) from engine (13).
6. Remove screw (14), retaining band (15), transmission dipstick tube (12), and seal (16) from transmission (8). Discard seal (16).

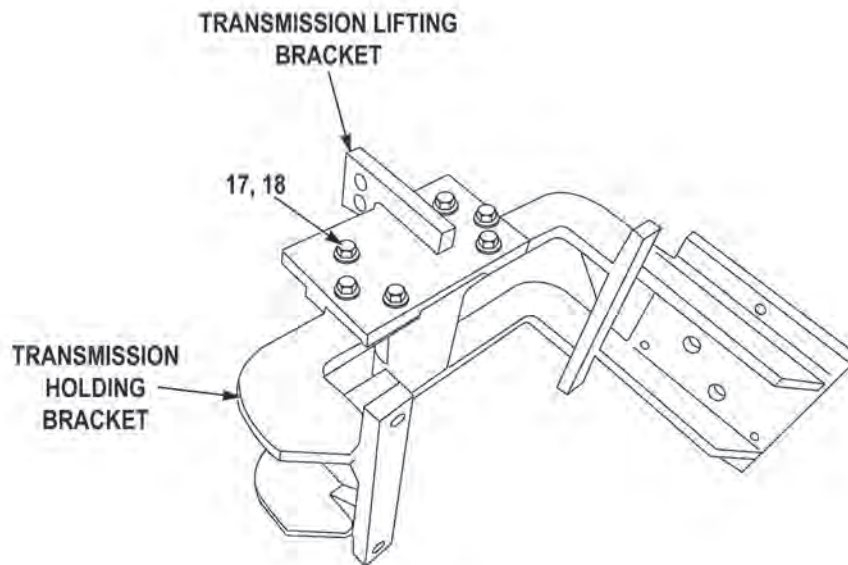

7. Install transmission lifting bracket on transmission holding bracket with six washers (17) and screws (18).

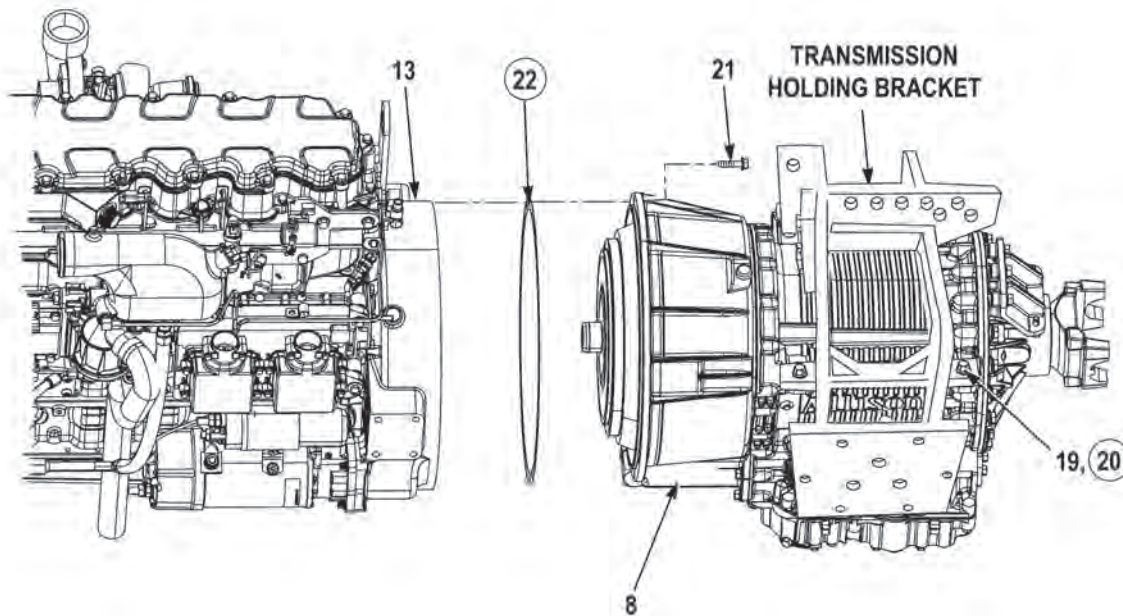

### **WARNING**

**Transmission holding bracket weighs 93 lbs (42 kg). Do not attempt to lift or move transmission holding bracket without the aid of an assistant and a lifting device. Failure to comply may result in injury or death to personnel.**

8. Attach lifting device to transmission holding bracket.
9. With the aid of an assistant and lifting device, install transmission holding bracket on transmission (8) with four screws (19) and locknuts (20).

### **WARNING**

**Transmission weighs 700 lbs (318 kg). Do not lift or move transmission without the aid of an assistant and lifting device. Failure to comply may result in injury or death to personnel.**

10. With the aid of an assistant and lifting device, remove 12 screws (21), transmission (8), and gasket (22) from engine (13). Discard gasket (22).

**END OF TASK**



## ENGINE PREPARATION FOR SHIPMENT

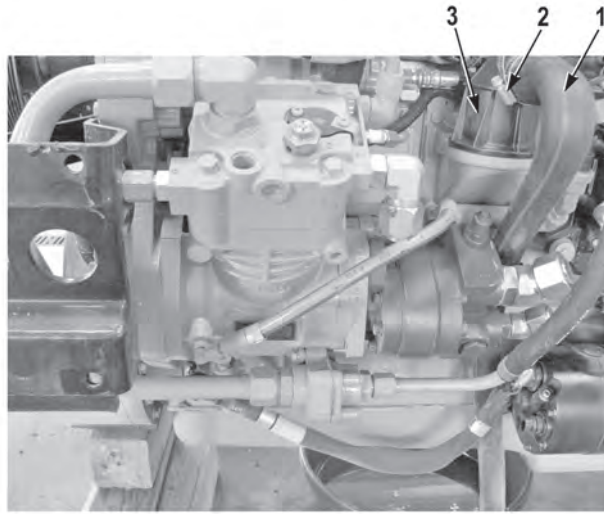

1. Install hose (1) on engine breather assembly (3) with clamp (2).

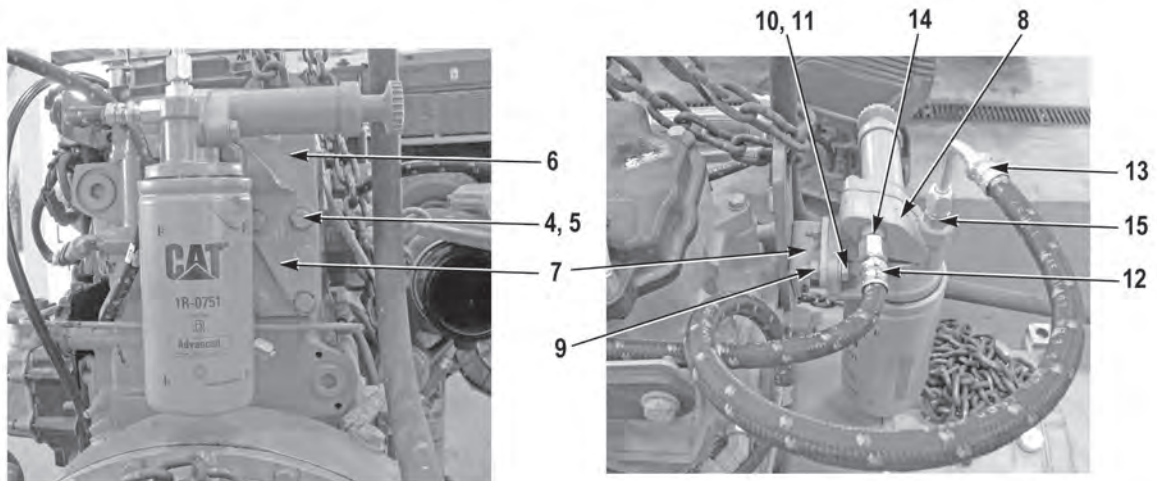

2. Remove three screws (4) and washers (5) from rear lift bracket (6).
3. Install adapter bracket (7) on rear lift bracket (6) with three washers (5) and screws (4).
4. Install secondary fuel filter assembly (8) on adapter bracket (7) with two washers (10), screws (11), and nuts (9).
5. Install hose (12) on fitting (14).
6. Install hose (13) on fitting (15).

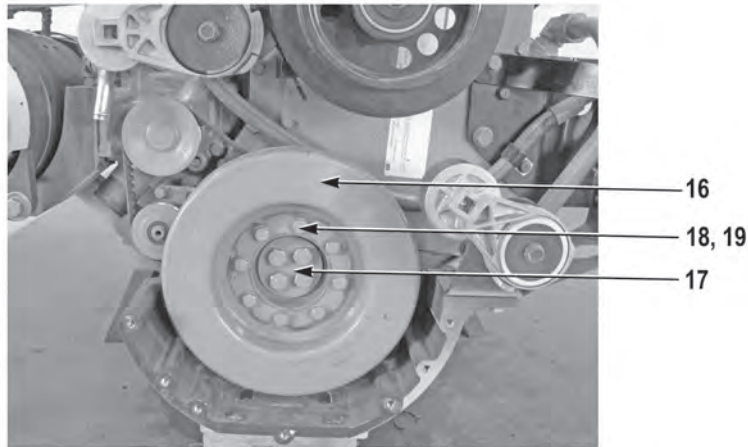

7. Install vibration damper (16) on crankshaft adapter (17) with eight washers (18) and screws (19).

#### END OF TASK

#### ENGINE PREPARATION FOR INSTALLATION

1. Remove eight screws (19), washers (18), and vibration damper (16) from crankshaft adapter (17).

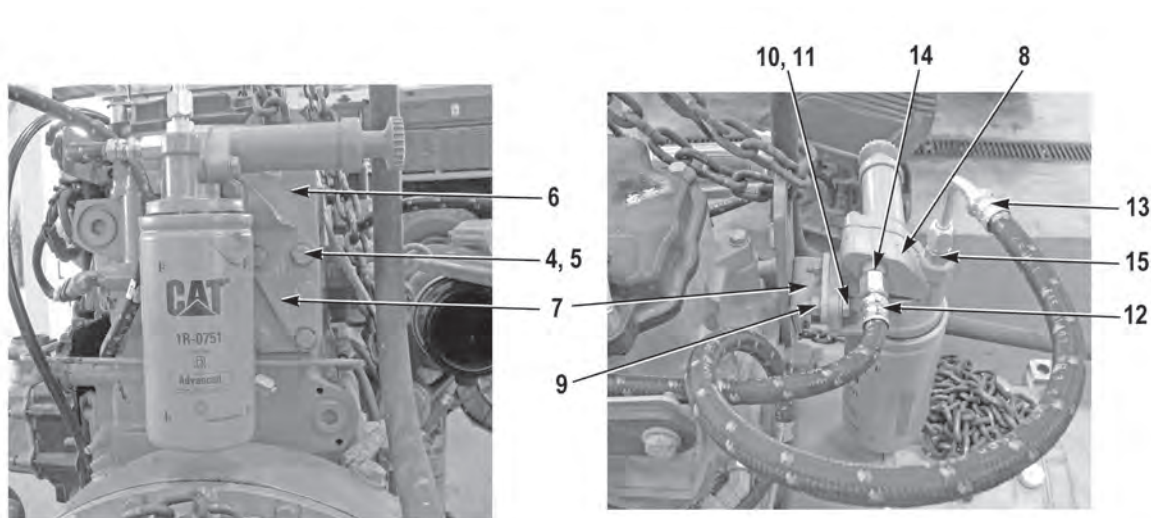

2. Remove hose (13) from fitting (15).
3. Remove hose (12) from fitting (14).
4. Remove two nuts (9), screws (11), washers (10), and secondary fuel filter assembly (8) from adapter bracket (7).

5. Remove three screws (4), washers (5), and adapter bracket (7) from rear lift bracket (6).
6. Install three washers (5) and screws (4) on rear lift bracket (6).

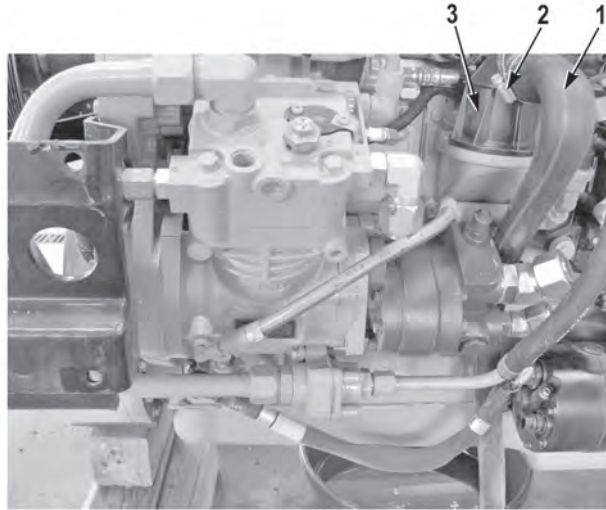

7. Loosen clamp (2) and remove hose (1) and clamp (2) from engine breather assembly (3).

**END OF TASK**

## ENGINE/TRANSMISSION ASSEMBLY

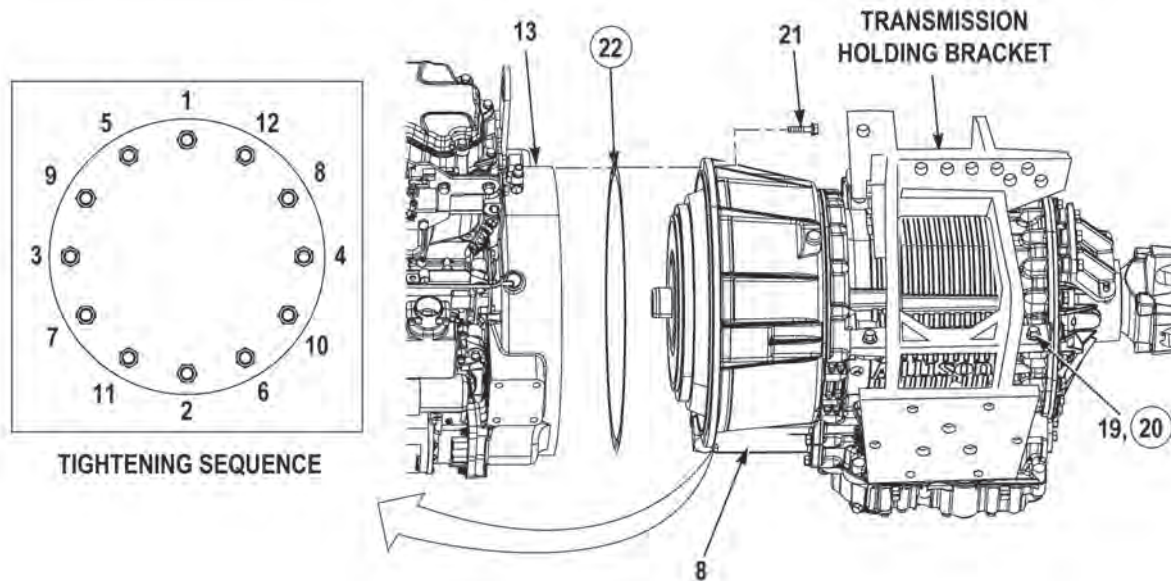
**WARNING**

- Transmission weighs 700 lbs (318 kg). Do not lift or move transmission without the aid of an assistant and lifting device. Failure to comply may result in injury or death to personnel.
- Adhesives, solvents, and sealing compounds can burn easily, can give off harmful vapors, and are harmful to skin and clothing. To avoid injury or death, keep away from open fire and use in well-ventilated area. If adhesive, solvent, or sealing compound gets on skin or clothing, wash immediately with soap and water. Failure to comply may result in injury or death to personnel.

**NOTE**

Tighten screws in a criss-cross pattern.

1. Apply sealing compound, Loctite 242, to threads of 12 screws (21) and with the aid of an assistant and lifting device, install gasket (22) and transmission (8) on engine (13) with 12 screws (21). Tighten screws (21) to 42 lb-ft (57 N·m) in sequence shown.

**WARNING**

**Transmission holding bracket weighs 93 lbs (42 kg). Do not attempt to lift or move transmission holding bracket without the aid of an assistant and a lifting device. Failure to comply may result in injury or death to personnel.**

2. With the aid of an assistant and lifting device, remove four locknuts (20), screws (19), and transmission holding bracket from transmission (8). Discard locknuts (20).



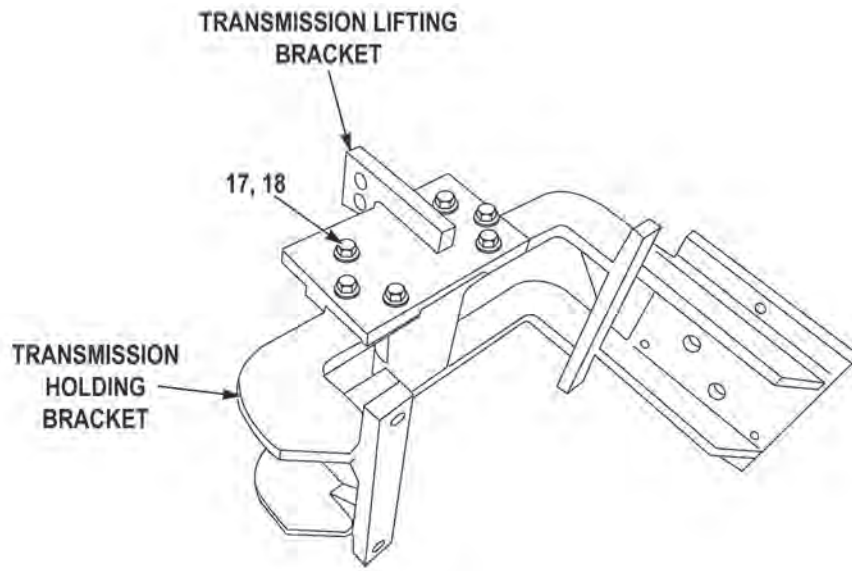

- Remove six screws (18), washers (17), and transmission lifting bracket from transmission holding bracket.

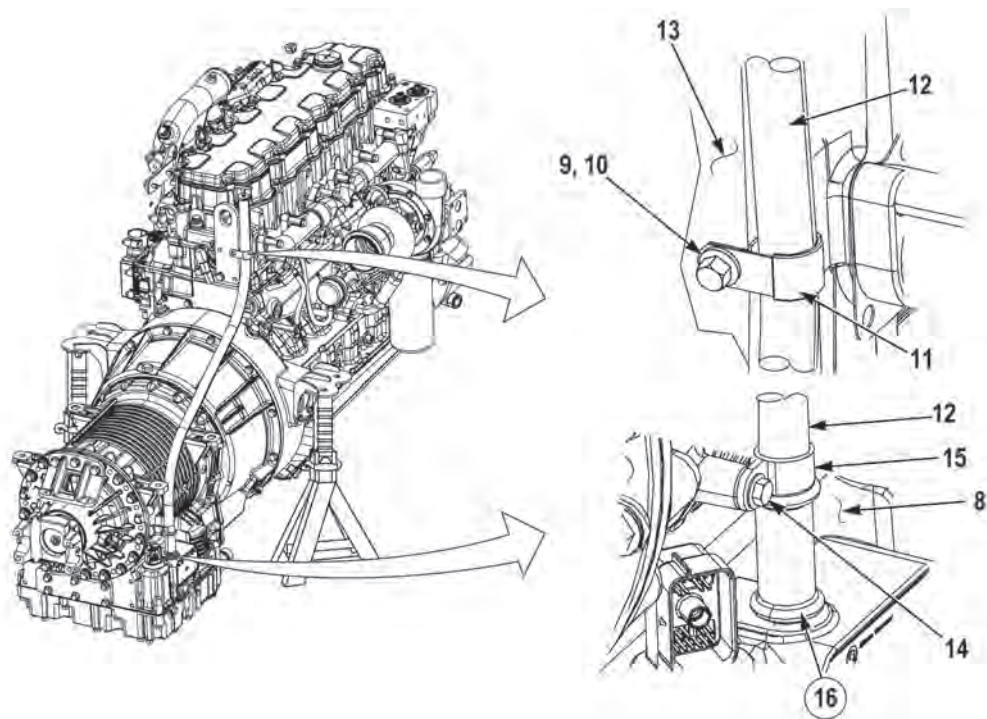

- Lightly lubricate seal (16) with clean oil and position seal (16) and transmission dipstick tube (12) on transmission (8).
- Install transmission dipstick tube (12) on engine (13) with cushion clip (11), washer (10), and screw (9).
- Install transmission dipstick tube (12) and retaining band (15) on transmission (8) with screw (14).

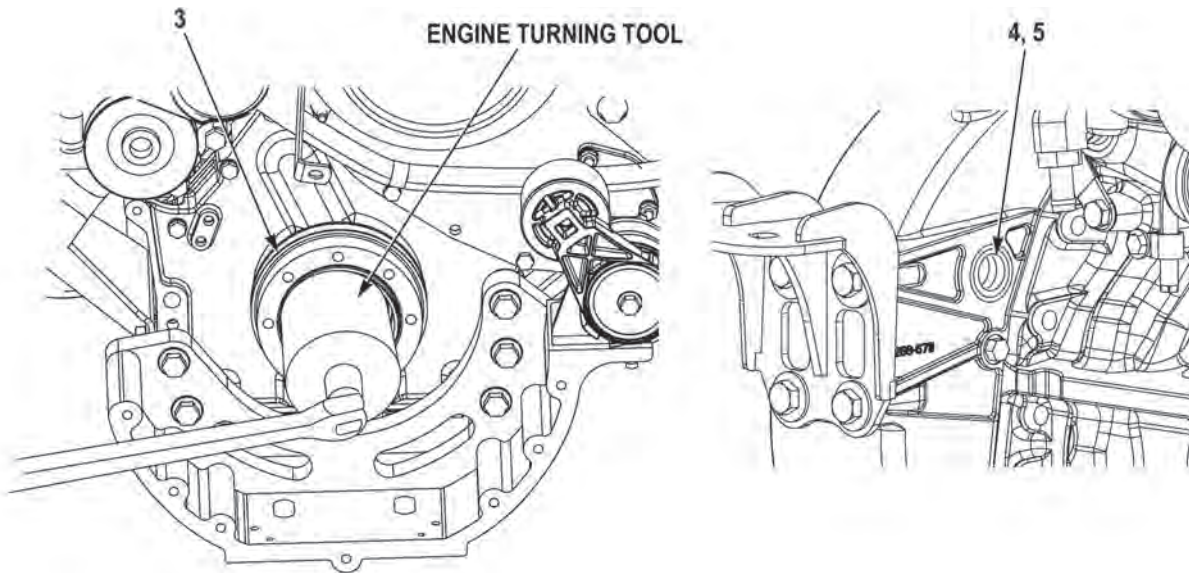

7. Using engine turning tool socket and the aid of an assistant, rotate crankshaft adapter (3) while assistant notes when flexplate attach screw mounting hole (4) becomes visible in hole on flywheel housing (5).

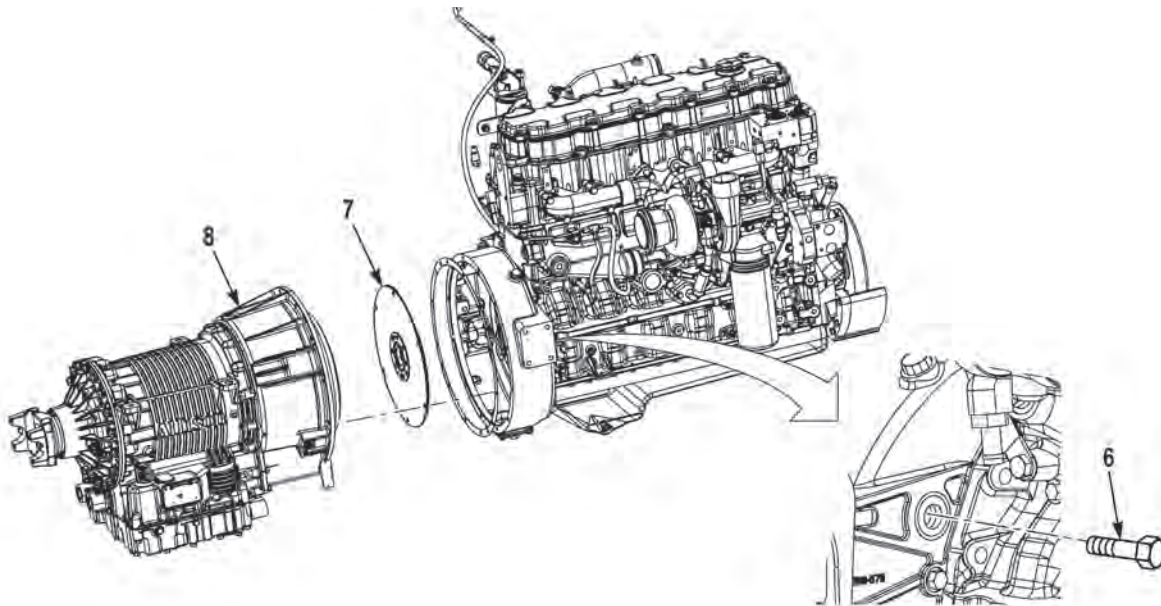

### **WARNING**

**Adhesives, solvents, and sealing compounds can burn easily, can give off harmful vapors, and are harmful to skin and clothing. To avoid injury or death, keep away from open fire and use in well-ventilated area. If adhesive, solvent, or sealing compound gets on skin or clothing, wash immediately with soap and water. Failure to comply may result in injury or death to personnel.**

8. Apply sealing compound, Loctite 242, to threads of screw (6) and secure flexplate (7) to transmission (8) with screw (6). Tighten screw (6) to 50 lb-ft (67.8 N·m).
9. Repeat Steps (7) and (8) for remaining flexplate attach screws (6).



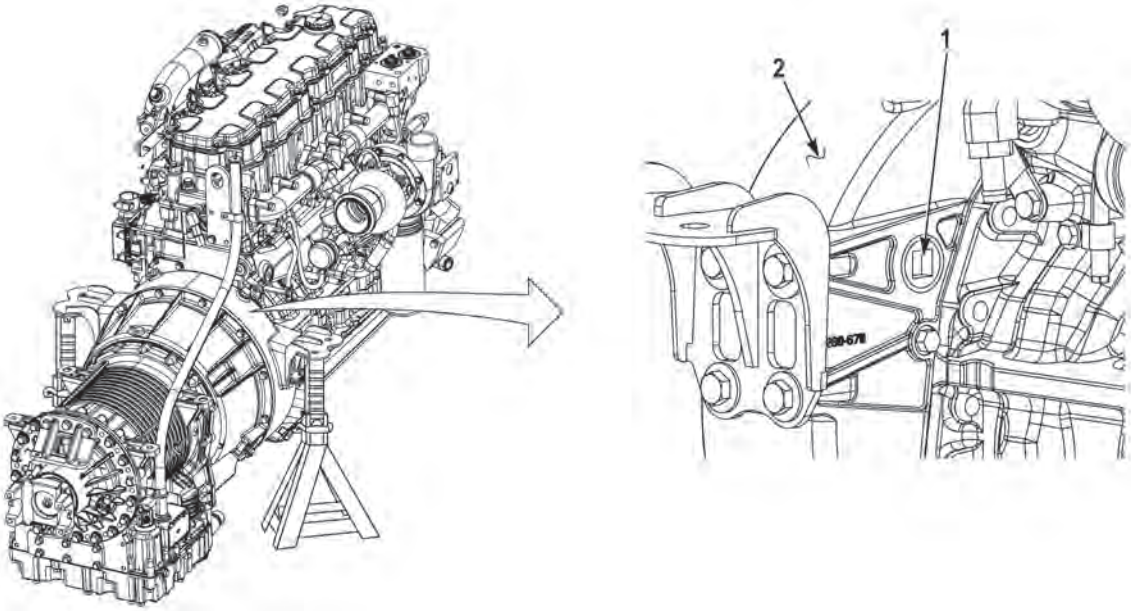

10. Install plug (1) on flywheel housing (2).
11. Perform all Follow-On Maintenance tasks.

**END OF TASK**

**END OF WORK PACKAGE**



---

**RING GEAR AND FLEXPLATE ADAPTER REPLACEMENT**

---

**Preconditions**

Park vehicle  
Engine OFF  
Wheels chocked  
Powertrain removed (WP 0227)  
Transmission separated from engine

**Tools and Special Tools**

Tool Kit, General Mechanic's: Automotive

**Materials/Parts**

Wrench, Torque 75 ft-lb

**Follow-On Maintenance**

Install transmission on engine  
Install powertrain (WP 0227)  
Remove and stow wheel chocks

---

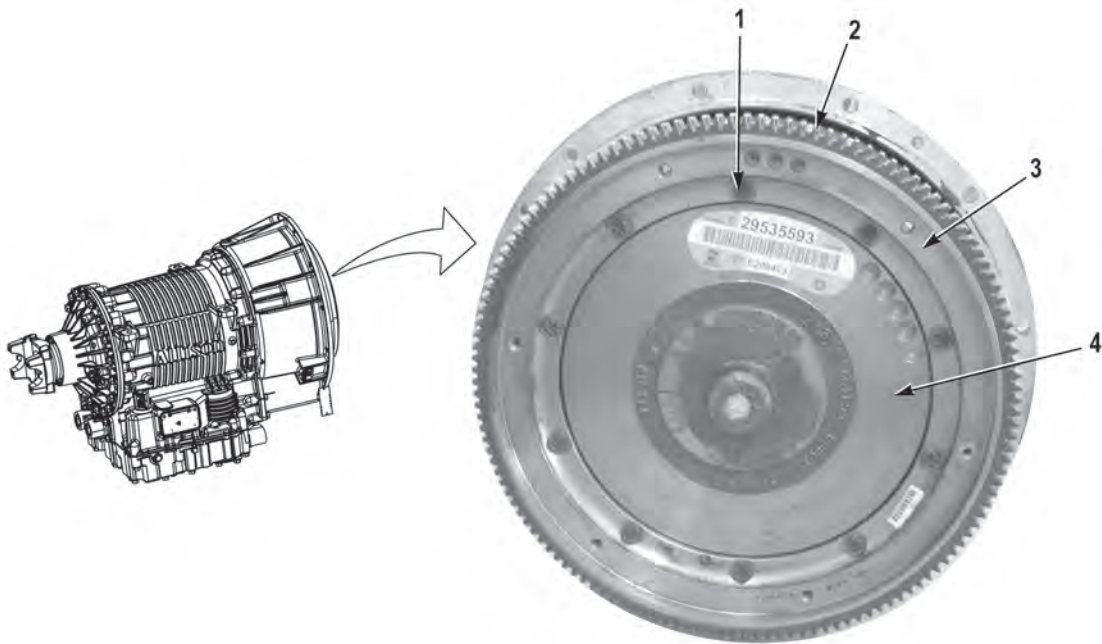
**REMOVAL****NOTE**

Ring gear and flexplate adapter are removed as an assembly.

1. Remove ten screws (1), ring gear (2), and flexplate adapter (3) from torque converter (4).

**END OF TASK**

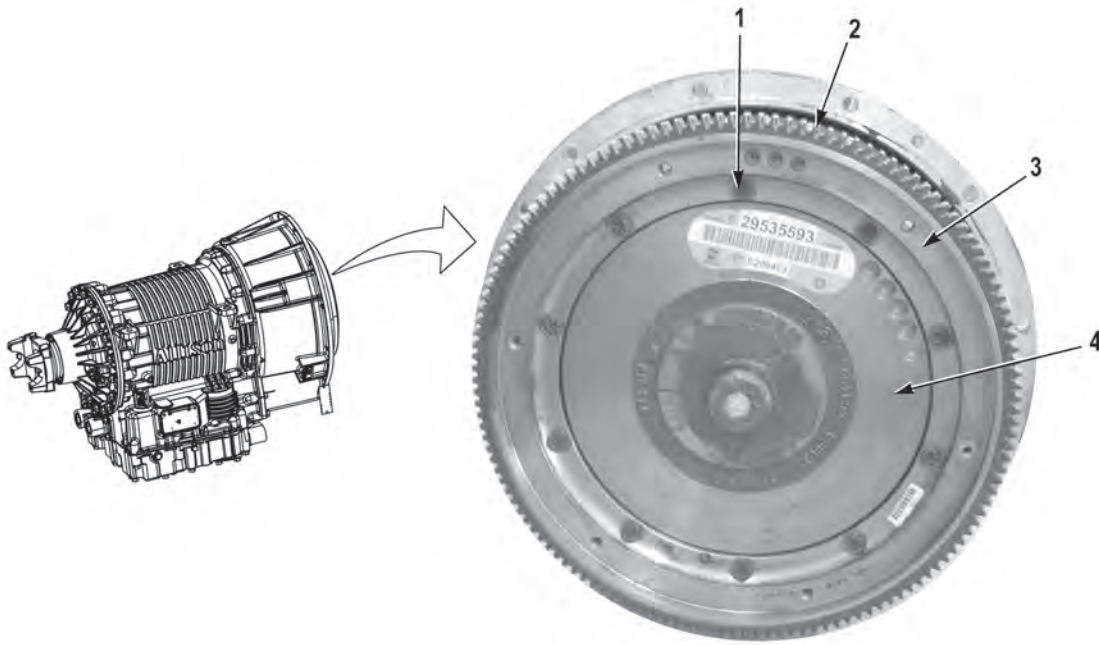
**INSTALLATION****NOTE**

Ring gear and flexplate adapter are installed as an assembly.

1. Install ring gear (2) and flexplate adapter (3) on torque converter (4) with ten screws (1). Tighten screws (1) in a star pattern to 18 to 21 lb-ft (24 to 29 N•m).
2. Perform all Follow-On Maintenance tasks.

**END OF TASK**

**END OF WORK PACKAGE**

---

**TRANSMISSION BREATHER REPLACEMENT**

---

**Preconditions**

Park vehicle  
Engine OFF  
Wheels chocked  
Hood opened and secured

**Materials/Parts**

Compound, Sealing, Loctite 592

**Follow-On Maintenance**

Close hood and secure  
Remove and stow wheel chocks

**Tools and Special Tools**

Tool Kit, General Mechanic's: Automotive

---

**REMOVAL****WARNING**

Exhaust pipe may be hot. Do not touch hot exhaust pipe. Failure to comply may result in injury to personnel.

**NOTE**

- Breather can be accessed easiest from passenger side of engine.
- Access to breather may be easier from below vehicle with armor removed.

1. Remove breather (1) from transmission (2).

**END OF TASK**

**INSTALLATION****WARNING**

**Adhesives, solvents, and sealing compounds can burn easily, can give off harmful vapors, and are harmful to skin and clothing. To avoid injury or death, keep away from open fire and use in well-ventilated area. If adhesive, solvent, or sealing compound gets on skin or clothing, wash immediately with soap and water. Failure to comply may result in injury or death to personnel.**

1. Apply sealing compound, Loctite 592, to threads of breather (1).
2. Install breather (1) on transmission (2).
3. Perform all Follow-On Maintenance tasks.

**END OF TASK****END OF WORK PACKAGE**



---

**TRANSMISSION COOLER REPLACEMENT**

---

**Preconditions**

Park vehicle  
 Engine OFF  
 Wheels chocked  
 Hood opened and secured  
 Radiator removed (WP 0180)

**Tools and Special Tools**

Pan, Drain  
 Tool Kit, General Mechanic's: Automotive

**Materials/Parts**

O-ring (Item 6)  
 O-ring (Item 8)  
 Compound, Sealing, Loctite 569  
 Lubricating Oil, Engine

**Follow-On Maintenance**

Install radiator (WP 0180)  
 Close hood and secure  
 Remove and stow wheel chocks

---

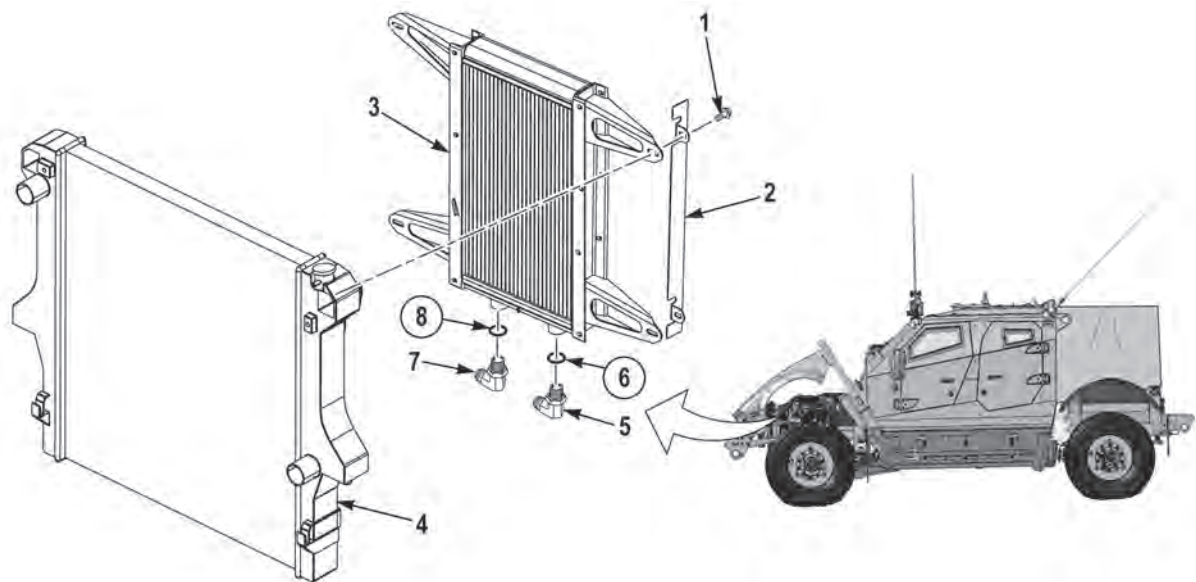
**REMOVAL**

1. Remove four screws (1), two brackets (2), and transmission cooler (3) from radiator (4).

**NOTE**

Note position of fittings prior to removal to ensure proper installation.

2. Remove fitting (5) and O-ring (6) from transmission cooler (3). Discard O-ring (6).
3. Remove fitting (7) and O-ring (8) from transmission cooler (3). Discard O-ring (8).

**END OF TASK**

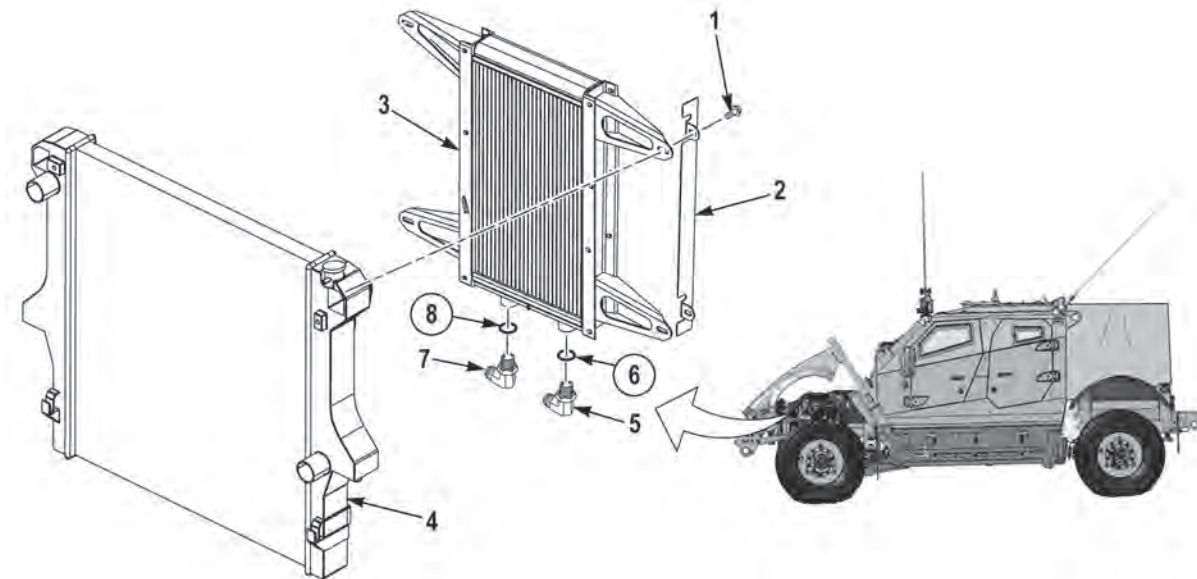
**INSTALLATION****WARNING**

Adhesives, solvents, and sealing compounds can burn easily, can give off harmful vapors, and are harmful to skin and clothing. To avoid injury or death, keep away from open fire and use in well-ventilated area. If adhesive, solvent, or sealing compound gets on skin or clothing, wash immediately with soap and water. Failure to comply may result in injury or death to personnel.

**NOTE**

Install fittings as noted prior to removal.

1. Apply sealing compound, Loctite 569, to two fittings (7 and 5).
2. Lightly lubricate new O-ring (8) with clean oil and install O-ring (8) and fitting (7) on transmission cooler (3).
3. Lightly lubricate new O-ring (6) with clean oil and install O-ring (6) and fitting (5) on transmission cooler (3).
4. Install transmission cooler (3) and two brackets (2) on radiator (4) with four screws (1).
5. Perform all Follow-On Maintenance tasks.

**END OF TASK**

**END OF WORK PACKAGE**

---

**TRANSMISSION DRAIN/FILL**

---

**Preconditions**

Park vehicle  
 Engine OFF  
 Wheels chocked  
 Hood opened and secured  
 Center belly deflector panel removed  
 (M1240/M1245) (WP 0048)  
 Center belly deflector panel removed (M1240A1)  
 (WP 0056)

**Tools and Special Tools**

Pan, Drain  
 Tool Kit, General Mechanic's: Automotive  
 Wrench, Torque, 75 ft-lb

**Materials/Parts**

O-ring (Item 2)  
 Lubricating Oil, Transmission  
 Rags, Wiping

**Follow-On Maintenance**

Install center belly deflector panel  
 (M1240/M1245) (WP 0048)  
 Install center belly deflector panel (M1240A1)  
 (WP 0056)  
 Close hood and secure  
 Remove and stow wheel chocks

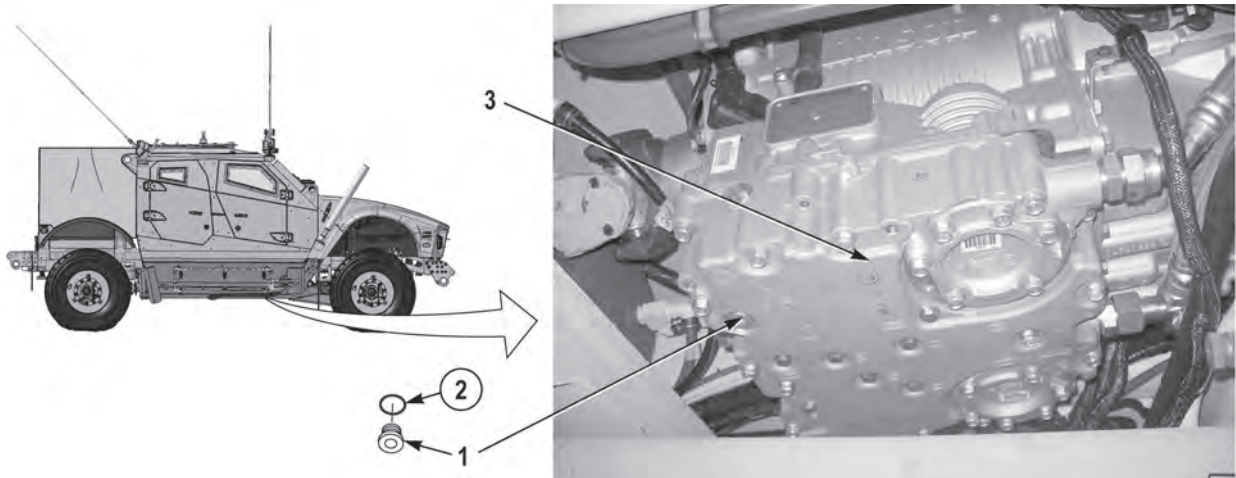
**DRAIN****NOTE**

Park vehicle on level surface prior to performing this task.

1. Position suitable drain pan under transmission drain plug (1).

**WARNING**

**Ensure transmission oil is cool prior to draining transmission oil. Failure to comply may result in injury to personnel.**

2. Remove plug (1) and O-ring (2) from transmission (3) and allow oil to drain completely. Discard O-ring (2).
3. Lightly lubricate new O-ring (2) with clean oil and install O-ring (2) and drain plug (1) on transmission (3). Tighten drain plug (1) to 18 to 24 lb-ft (25 to 32 N•m).

**END OF TASK**

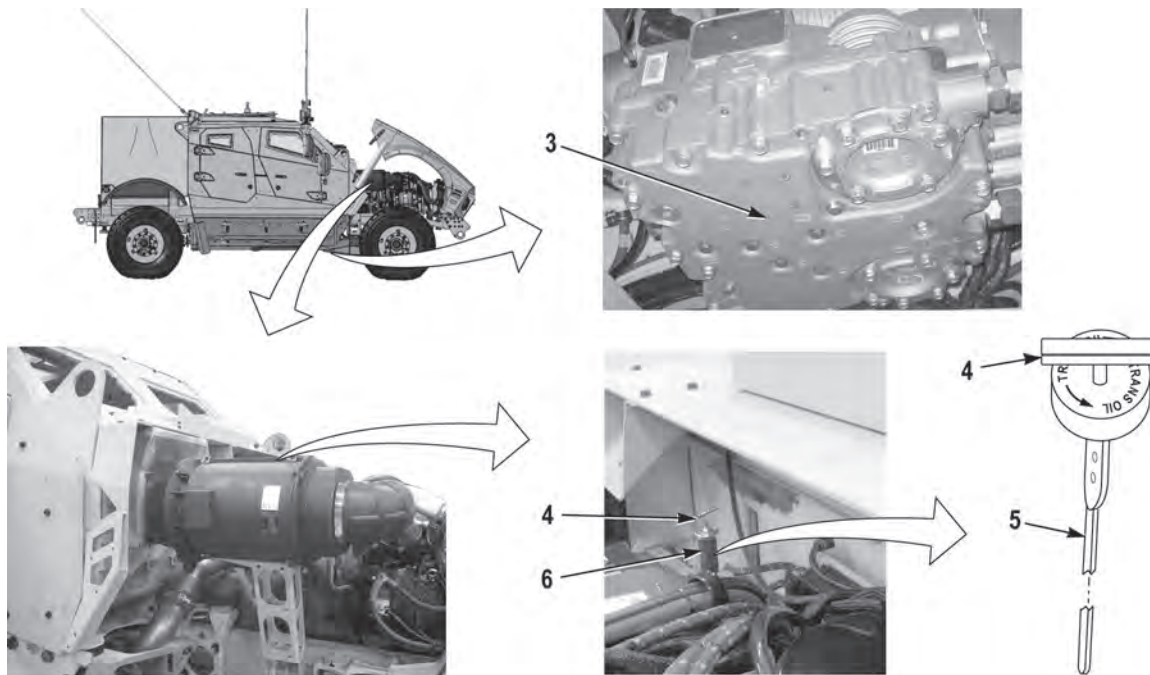
**FILL****CAUTION**

**Do not permit dirt, dust, or grit to enter transmission filler tube. Thoroughly clean dipstick handle and end of filler tube. Failure to comply may result in damage to equipment.**

1. Turn fill cap/dipstick T-handle (4) counterclockwise until dipstick (5) is loose in tube (6).
2. Remove dipstick (5) from tube (6).
3. Fill transmission (3) through filler tube (6).

**NOTE**

Oil level must be within COLD RUN band on dipstick.

4. After wiping dipstick (5) clean, check oil level.
5. Repeat Steps (3) and (4) if oil level is not within COLD RUN band on dipstick (5).
6. Install dipstick (5) in tube (6).
7. Turn fill cap/dipstick T-handle (4) clockwise until snug.

**CAUTION**

The transmission must not be operated for extended periods of time until a hot check has verified proper oil level. Do not operate transmission for extended periods at improper oil level conditions. Failure to comply may result in damage to equipment.

**NOTE**

An accurate oil level check cannot be made unless engine idling (500 to 800 rpm) in N (Neutral) and transmission oil is at proper temperature of 160 to 200°F (71 to 93°C).

8. Start engine.

**NOTE**

Vehicle may have to be driven to achieve proper operating temperature.

9. Apply service brake and shift to drive, reverse, then to neutral.

**CAUTION**

Do not permit dirt, dust, or grit to enter transmission filler tube. Thoroughly clean dipstick handle and end of filler tube. Failure to comply may result in damage to equipment.

10. Refer to TM 9-2355-335-10 for HOT CHECK.
11. Perform all Follow-On Maintenance tasks.

**END OF TASK**

**END OF WORK PACKAGE**





---

**TRANSMISSION FILTER REPLACEMENT**

---

**Preconditions**

Park vehicle  
 Engine OFF  
 Wheels chocked  
 Transmission drained (WP 0232)

**Tools and Special Tools**

Pan, Drain  
 Tool Kit, General Mechanic's: Automotive

**Materials/Parts**

Filter (2) (Item 3)  
 Gasket (2) (Item 5)  
 O-ring (2) (Item 6)  
 O-ring (2) (Item 7)  
 Lubrication, Oil, Transmission

**Follow-On Maintenance**

Fill transmission (WP 0232)  
 Remove and stow wheel chocks

---

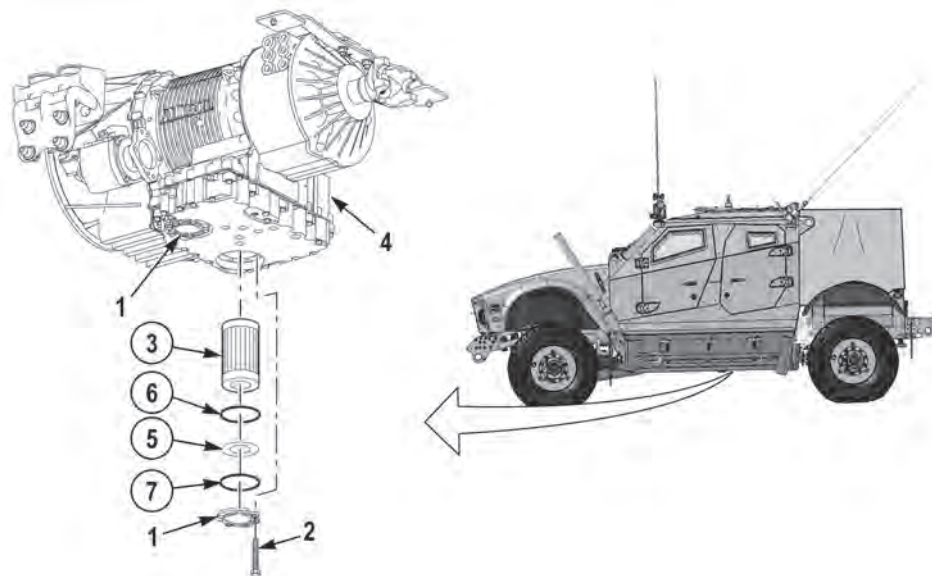
**REMOVAL****NOTE**

There are two transmission filters. Both filters are removed the same way.

1. Position suitable drain pan under transmission cover (1).
2. Remove six screws (2), cover (1), and filter (3) from transmission (4).
3. Remove gasket (5), O-ring (6), and O-ring (7) from cover (1) and filter (3). Discard gasket (5) and O-rings (6 and 7) and filter (3).

**END OF TASK**

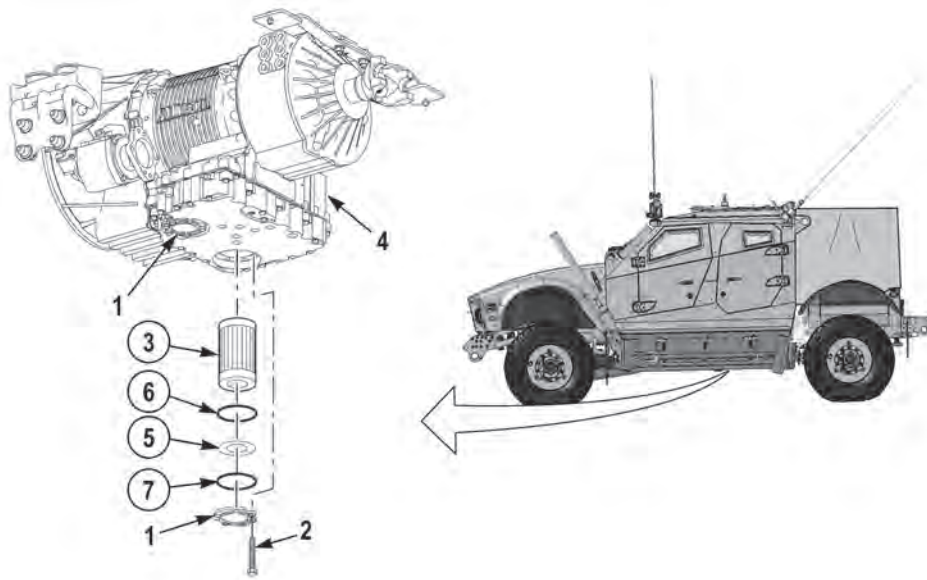
**INSTALLATION****NOTE**

There are two transmission filters. Both filters are installed the same way.

1. Apply lubricating oil to new gasket (5), two new O-rings, (6 and 7) and install on cover (1).
2. Install new filter (3) on cover (1).

**CAUTION**

**Do not use mounting screws to draw filter cover to the sump. Failure to comply may result in damage to cover, seals, or sump.**

3. Install filter (3) and cover (1) on transmission (4) with six screws (2). Tighten screws to 38 to 45 lb-ft (52 to 61 N•m).

**CAUTION**

**Ensure transmission oil level is at normal operating range. Failure to comply may result in damage to transmission.**

4. Check transmission oil level (TM 9-2355-335-10).
5. Start engine and run for 5 minutes (TM 9-2355-335-10).
6. Shut OFF engine and re-check transmission oil level. Fill as required (TM 9-2355-335-10).
7. Perform all Follow-On Maintenance tasks.

**END OF TASK**

**END OF WORK PACKAGE**

---

**TRANSMISSION SPRING SUPPORT AND BRACKET REPLACEMENT**

---

**Preconditions**

Engine OFF  
 Wheels chocked  
 Center belly deflector panel removed  
 (M1240/M1245) (WP 0048)  
 Center belly deflector panel removed (M1240A1)  
 (WP 0056)

**Tools and Special Tools**

Jack, Floor  
 Tool Kit, General Mechanic's: Automotive

**Materials/Parts**

Locknut (2) (Item 3)

**Follow-On Maintenance**

Install center belly deflector panel  
 (M1240/M1245) (WP 0048)  
 Install center belly deflector panel (M1240A1)  
 (WP 0056)  
 Remove and stow wheel chocks

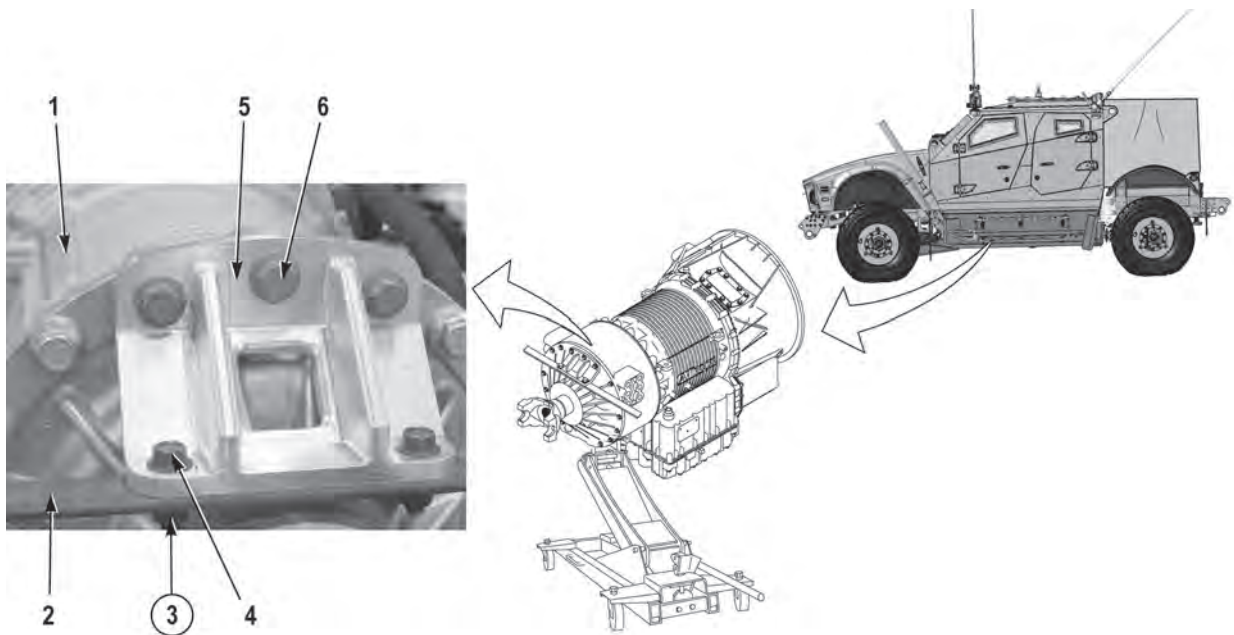
**REMOVAL**

1. Place jack under rear of transmission (1).

**CAUTION**

**Raise transmission only enough to release pressure on spring support. Failure to comply will result in damage to equipment.**

2. Raise transmission (1) enough to release pressure from spring support (2).
3. Remove two locknuts (3), screws (4), and spring support (2) from bracket (5). Discard locknuts (3).
4. Remove three screws (6) and bracket (5) from transmission (1).

**END OF TASK**

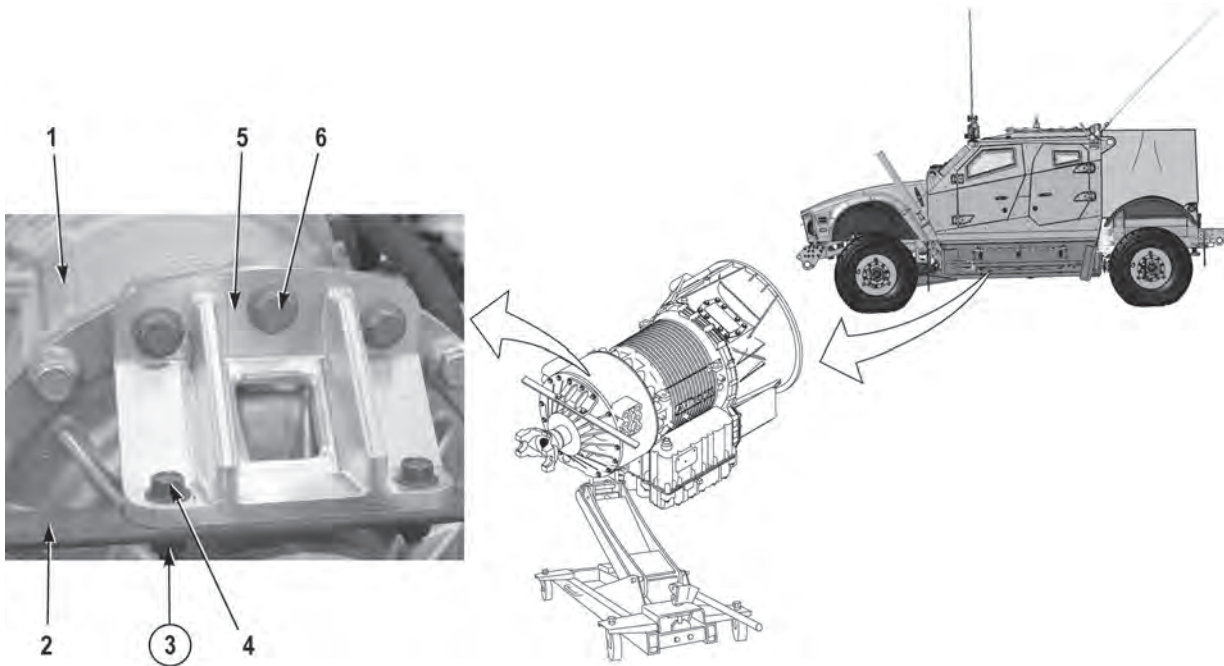
**INSTALLATION**

1. Install bracket (5) on transmission (1) with three screws (6).
2. Install spring support (2) on bracket (5) with two screws (4) and new locknuts (3).
3. Lower transmission (1) and remove jack.
4. Perform all Follow-On Maintenance tasks.

**END OF TASK****END OF WORK PACKAGE**

---

**TURBOCHARGER ASSEMBLY REPLACEMENT**

---

**Preconditions**

Park vehicle  
Engine OFF  
Wheels chocked  
Hood opened and secured  
Radiator drained (Reservoir equipped) (WP 0176)  
Radiator drained (Surge tank equipped)  
(WP 0177)

**Tools and Special Tools**

Tool Kit, General Mechanic's: Automotive

**Materials/Parts**

Locknut (2) (Item 4 and 7)  
Seal (2) (Item 16 and 24)  
Locknut (4) (Item 29)

**Materials/Parts (continued)**

Gasket (Item 31)  
O-Ring (2) (Item 33 and 34)  
Cap and Plug Set  
Coolant, Engine  
Tags, Identification

**Follow-On Maintenance**

Fill radiator (Reservoir equipped) (WP 0176)  
Fill radiator (Surge tank equipped) (WP 0177)  
Close hood and secure  
Remove and stow wheel chocks

---

**REMOVAL****WARNING**

**Engine components become hot during normal operation. Allow engine to cool completely prior to performing this task. Failure to comply may result in injury to personnel.**

**CAUTION**

**Ensure any open tube, line, or fitting on the turbocharger and its related systems are capped and plugged. Failure to comply may result in damage to equipment.**

**NOTE**

- Tag and mark air inlet and exhaust tubes prior to removal to ensure proper installation.
- Tag and mark coolant and oil lines and fittings prior to removal to ensure proper installation.
- Cap and plug all tubes, lines, and fittings upon removal.
- Note position of clamps prior to removal to ensure proper installation.

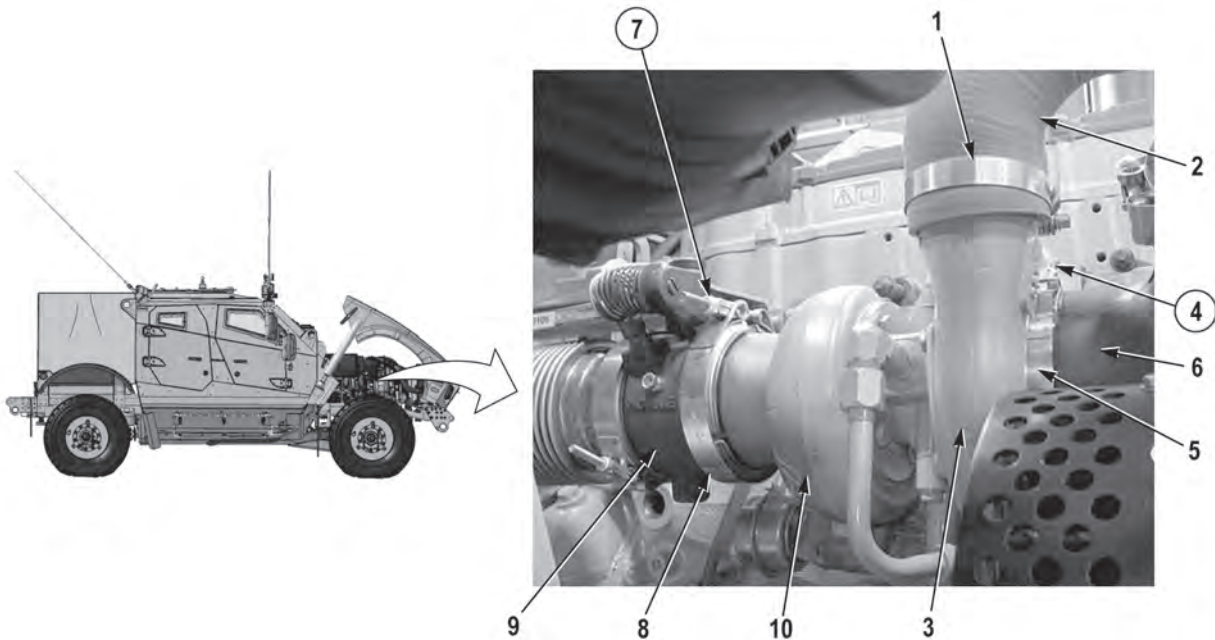

1. Loosen clamp (1) and remove air outlet duct (2) from compressor housing (3).
2. Remove locknut (4) and slide clamp (5) away from compressor housing (3) and onto air inlet tube (6) and remove air inlet tube (6) from compressor housing (3). Discard locknut (4).
3. Remove locknut (7) and slide clamp (8) away from engine brake assembly (9) and onto turbine housing (10). Discard locknut (7).



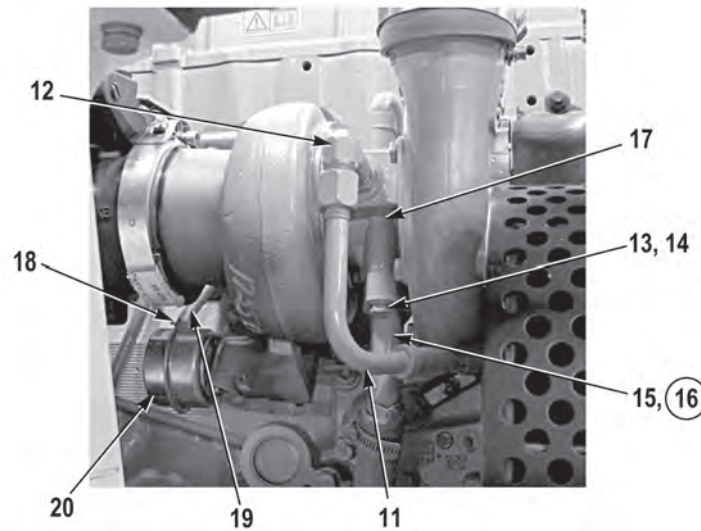

4. Remove coolant tube (11) from fitting (12).
5. Remove two screws (13), washers (14), oil drain tube (15), and seal (16) from center housing (17). Discard seal (16).
6. Remove clamp (18) and hose (19) from wastegate diaphragm (20).

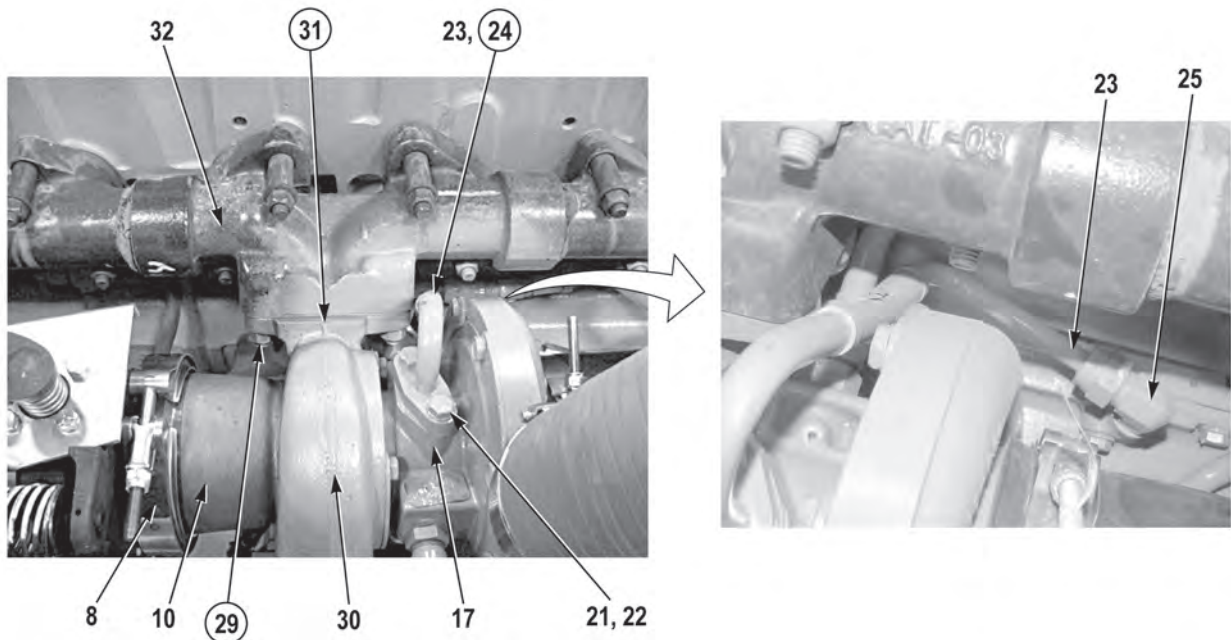

7. Remove two screws (21), washers (22), oil supply tube (23), and seal (24) from center housing (17). Discard seal (24).
8. Remove oil supply tube (23) from fitting (25).

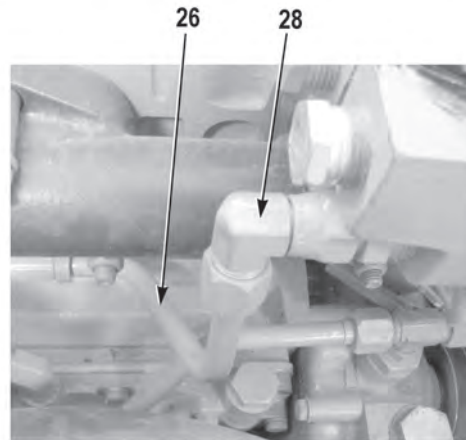
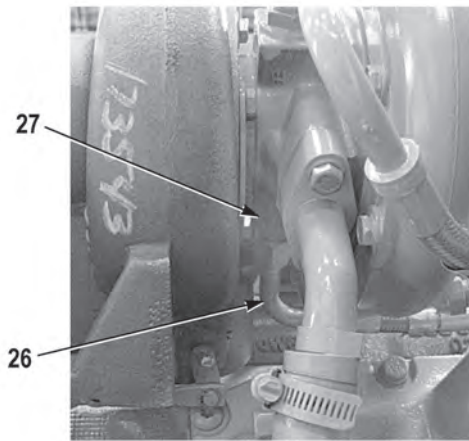

9. Remove coolant tube (26) from fitting (27).
10. Remove coolant tube (26) from fitting (28).

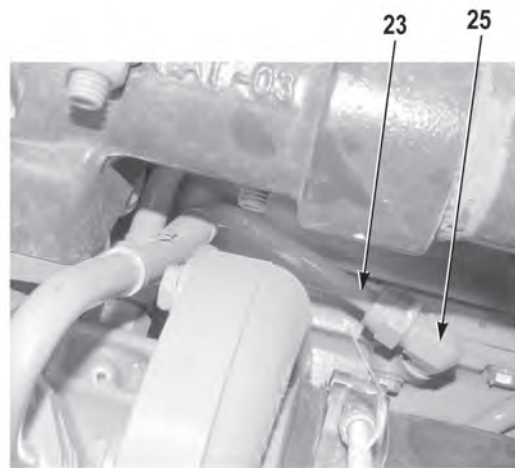
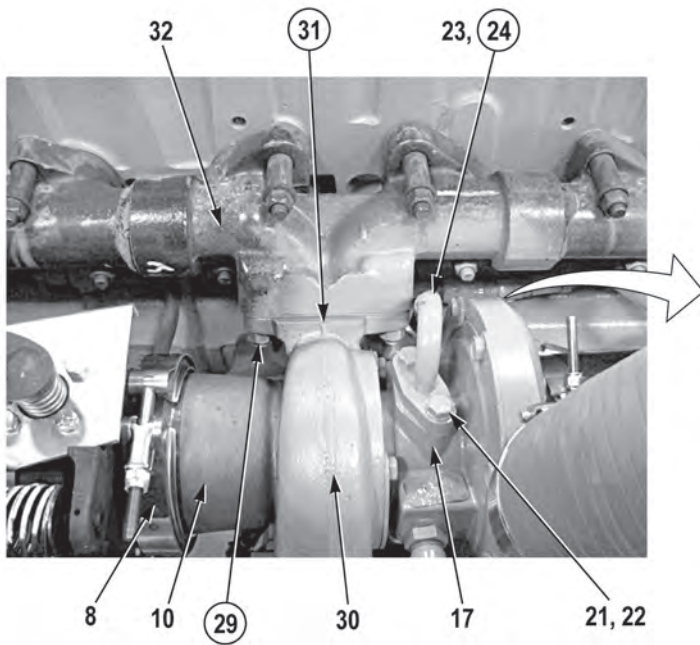

11. Remove four locknuts (29), turbocharger assembly (30), and gasket (31) from exhaust manifold (32). Discard locknuts (29) and gasket (31).
12. Remove clamp (8) from turbine housing (10).

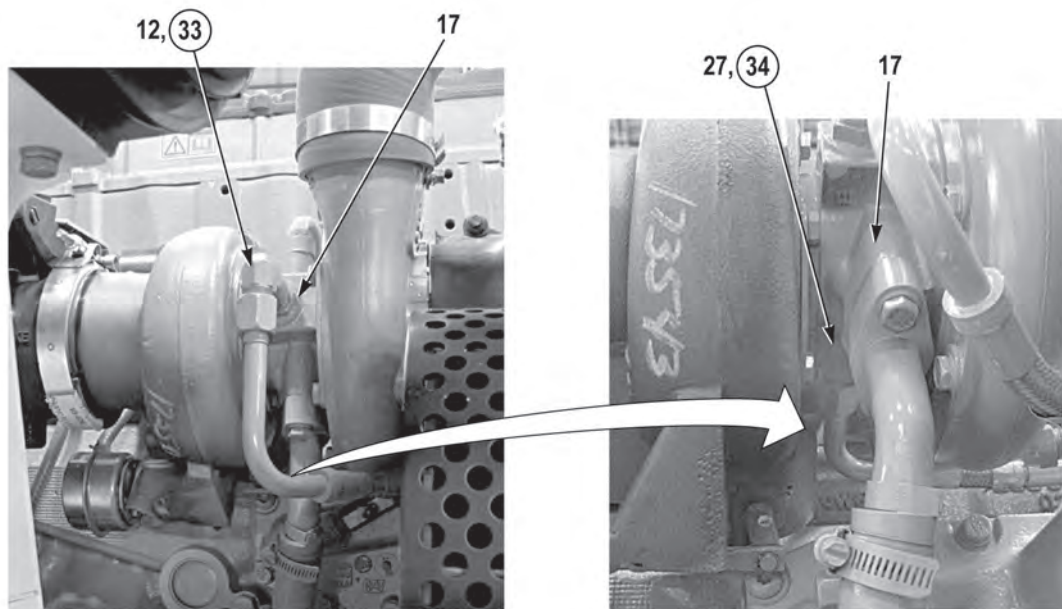

### NOTE

Note position of fittings prior to removal to ensure proper installation.

13. Remove two fittings (12 and 27) and O-rings (33 and 34) from center housing (17). Discard O-rings (33 and 34).

### END OF TASK

### INSTALLATION

### NOTE

Install fittings as noted prior to removal.

1. Lightly lubricate two new O-rings (33 and 34) with clean coolant and install two O-rings (33 and 34) and two fittings (12 and 27) on center housing (17).
2. Position clamp (8) on turbine housing (10).
3. Install new gasket (31) and turbocharger assembly (30) on exhaust manifold (32) with four new locknuts (29).
4. Install oil supply tube (23) on fitting (25).
5. Install new seal (24) and oil supply tube (23) on center housing (17) with two washers (22) and screws (21).

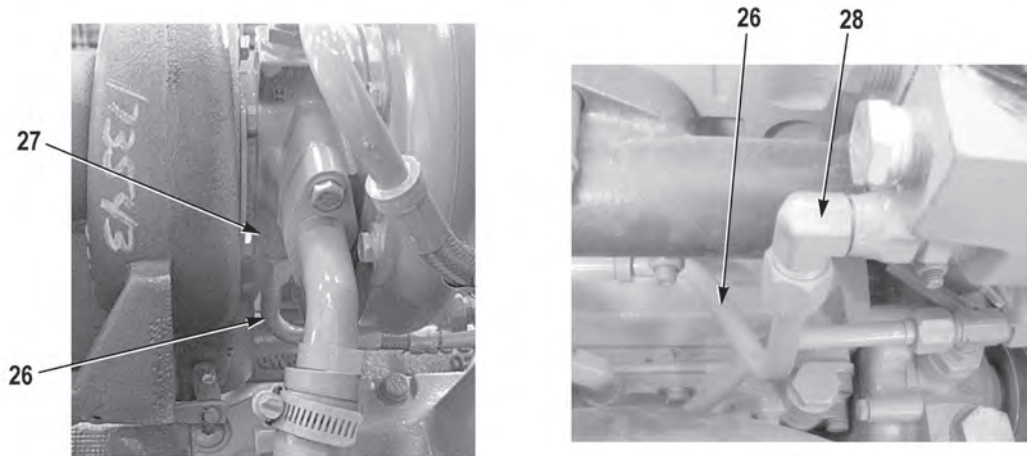

6. Install coolant tube (26) on fitting (28).
7. Install tube (26) on fitting (27).

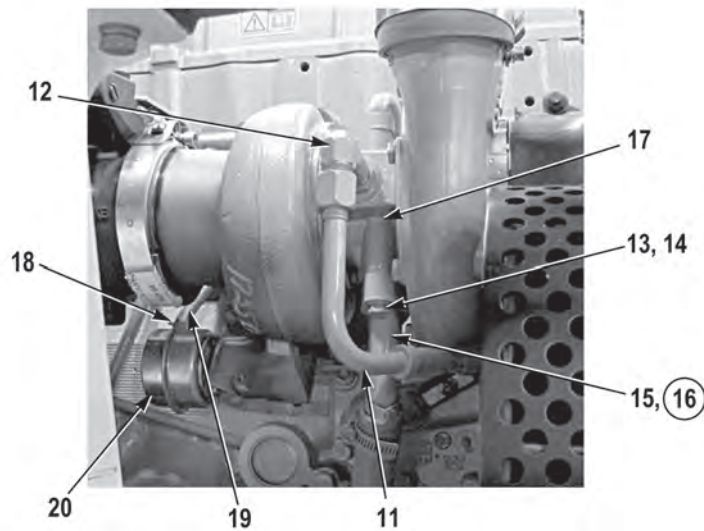

8. Install hose (19) on wastegate diaphragm (20) with clamp (18).
9. Install new seal (16) and oil drain tube (15) on center housing (17) with two washers (14) and screws (13).
10. Install coolant tube (11) on fitting (12).



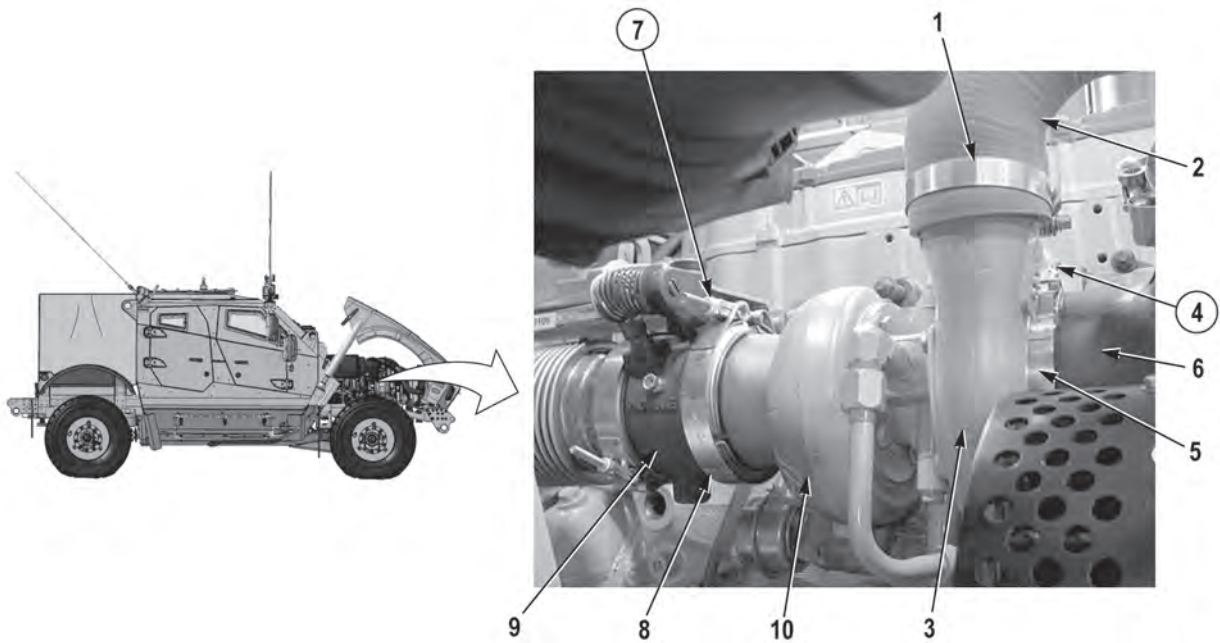

11. Install turbine housing (10) on engine brake assembly (9) with clamp (8) and new locknut (7).
12. Install air inlet tube (6) on compressor housing (3) with clamp (5) and new locknut (4).
13. Install air outlet duct (2) on compressor housing (3) with clamp (1).
14. Perform all Follow-On Maintenance tasks.

**END OF TASK**

**END OF WORK PACKAGE**





---

**VEHICLE INTERFACE MODULE (VIM) REPLACEMENT**

---

**Preconditions**

Park vehicle  
 Engine OFF  
 Wheels chocked  
 Batteries disconnected (M1240/M1240A1)  
 (WP 0186)

**Tools and Special Tools**

Tool Kit, General Mechanic's: Automotive

**Materials/Parts**

Locknut (3) (Item 9)  
 Lubricant, Connector, Nyogel 760G  
 Tags, Identification

**Follow-On Maintenance**

Connect batteries (M1240/M1240A1) (WP 0186)  
 Remove and stow wheel chocks

---

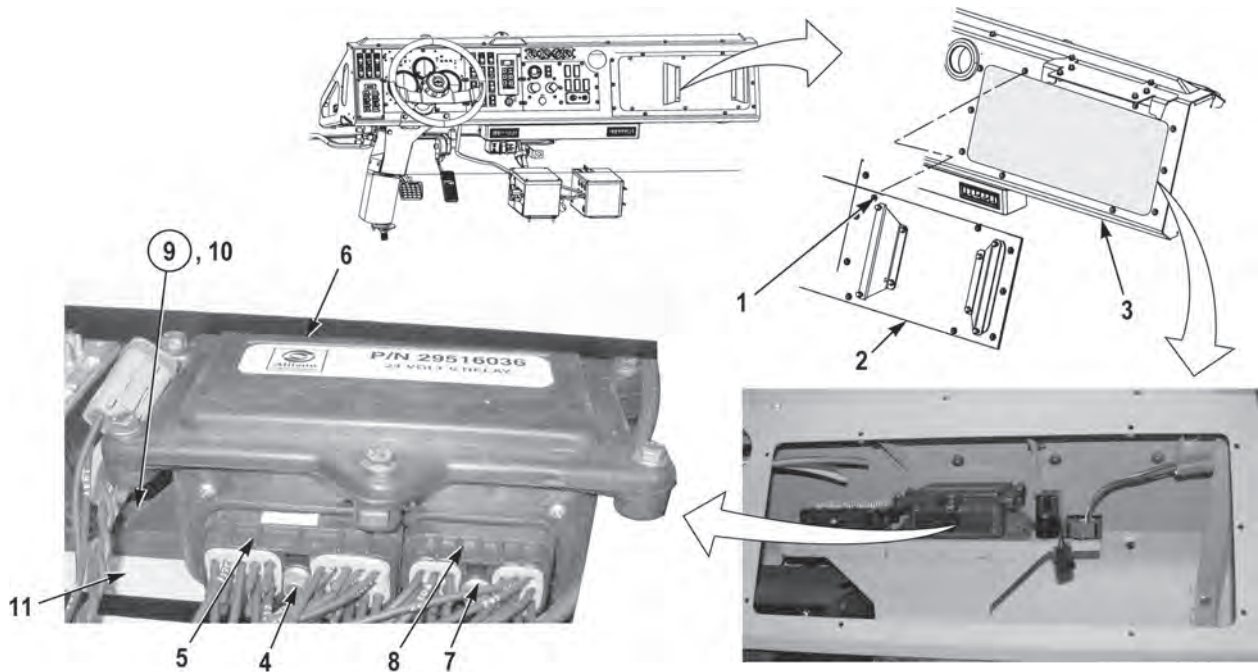
**REMOVAL**

1. Remove ten screws (1) and dash circuit breaker cover (2) from dash (3).

**NOTE**

Tag and mark connectors prior to removal to ensure proper installation.

2. Loosen screw (4) and remove connector (5) from vehicle interface module (6).
3. Loosen screw (7) and remove connector (8) from vehicle interface module (6).
4. Remove three locknuts (9), screws (10), and vehicle interface module (6) from dash panel compartment tray (11). Discard locknuts (9).

**END OF TASK**

## INSTALLATION

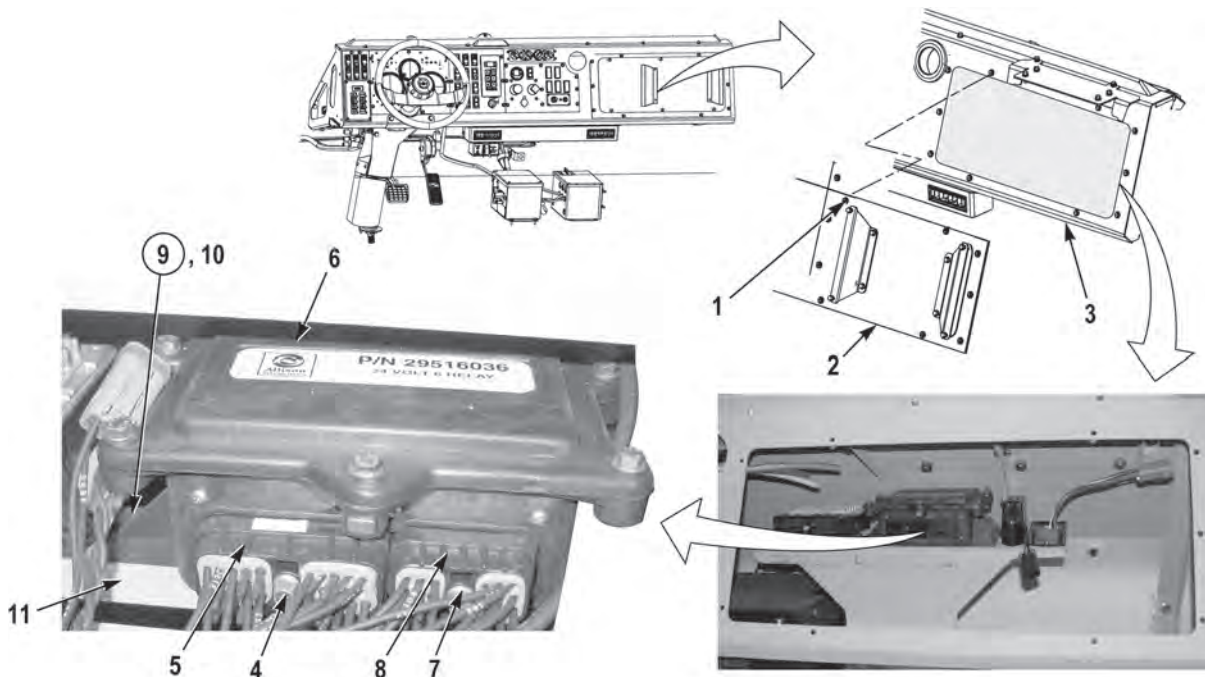

1. Install vehicle interface module (6) on dash panel compartment tray (11) with three screws (10) and new locknuts (9).

### **WARNING**

**Connector lubricant is harmful to skin. Prolonged or repeated contact with skin or contact with eyes may cause irritation. If eyes are contacted, rinse thoroughly and contact physician if irritation persists. If skin is contacted, wash thoroughly with soap and water. Failure to comply may result in injury or death to personnel.**

2. Apply connector lubricant, Nyogel 760G, to connector (8) and connector (5).
3. Connect connector (8) to vehicle interface module (6) and tighten screw (7).
4. Connect connector (5) to vehicle interface module (6) and tighten screw (4).
5. Install dash circuit breaker cover (2) on dash (3) with ten screws (1).
6. Perform all Follow-On Maintenance tasks.

**END OF TASK**

**END OF WORK PACKAGE**

---

**WATER PUMP BELT ADJUSTMENT**

---

**Preconditions**

Park vehicle  
 Engine OFF  
 Wheels chocked  
 Alternator drive belt removed (WP 0221)  
 Alternator removed (WP 0185)

**Materials/Parts**

None

**Follow-On Maintenance**

Install alternator (WP 0185)  
 Install alternator drive belt (WP 0221)  
 Remove and stow wheel chocks

**Tools and Special Tools**

Gauge, Belt Tension  
 Tool Kit, General Mechanic's: Automotive

---

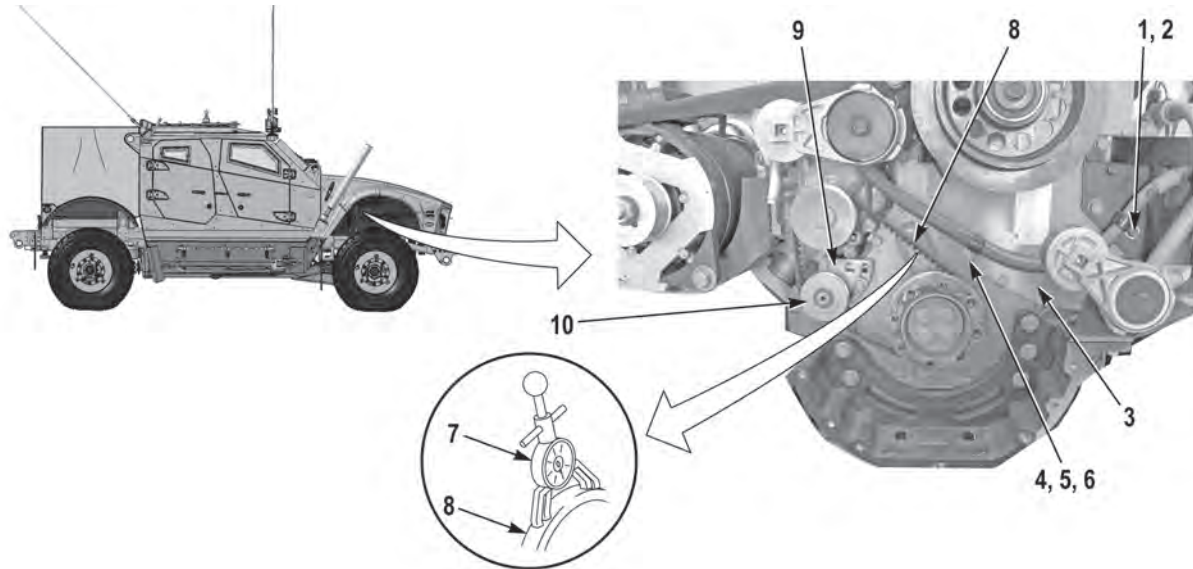
**ADJUSTMENT****NOTE**

Note position of cushion clips prior to removal to ensure proper installation.

1. Remove screw (1) and cushion clip (2) from engine (3).
2. Remove nut (4), washer (5), and cushion clip (6) from engine (3).
3. Place gauge (7) on belt (8) to ensure tension reads  $100 \pm 10$  lbs ( $445 \pm 44$  N).

**NOTE**

If tension of belt reads between  $100 \pm 10$  lbs ( $445 \pm 44$  N) no adjustment is required. If tension is not within range perform Steps (4) through (7).

4. Loosen two screws (9) enough to give play in belt tensioner pulley (10).

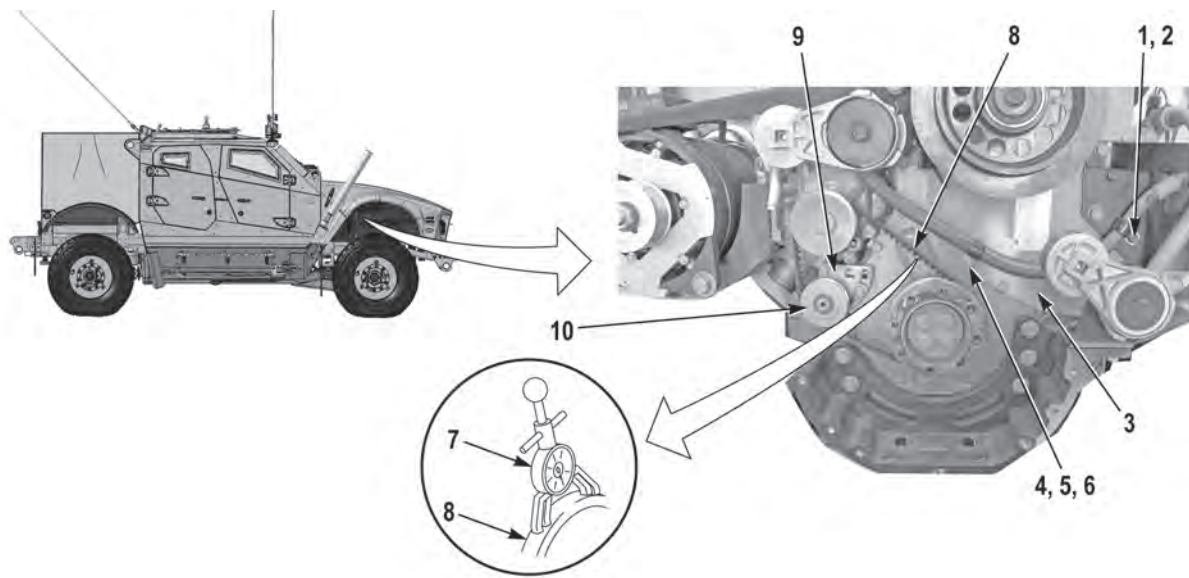

5. Using a breaker bar, apply sufficient pressure to obtain correct reading on gauge.
6. While holding steady pressure with breaker bar, tighten two screws (9). Tighten screws (9) to  $21 \pm 5$  lb-ft ( $28 \pm 7$  N•m).
7. Remove breaker bar.

### NOTE

Install cushion clips as noted prior to removal.

8. Install cushion clip (6) on engine (3) with washer (5) and nut (4).
9. Install cushion clip (2) on engine (3) with screw (1).
10. Perform all Follow-On Maintenance tasks.

**END OF TASK**

**END OF WORK PACKAGE**

---

## WATER PUMP BELT REPLACEMENT

---

**Preconditions**

Park vehicle  
Engine OFF  
Wheels chocked  
Hood opened and secured  
Alternator drive belt removed (WP 0221)  
Alternator removed (WP 0185)  
Fan clutch removed (WP 0178)

**Tools and Special Tools**

Tool Kit, General Mechanic's: Automotive

**Materials/Parts**

Compound, Sealing, Loctite 242

**Follow-On Maintenance**

Install alternator (WP 0185)  
Adjust water pump belt (WP 0237)  
Install fan clutch (WP 0178)  
Install alternator drive belt (WP 0221)  
Close hood and secure  
Remove and stow wheel chocks

---

### REMOVAL

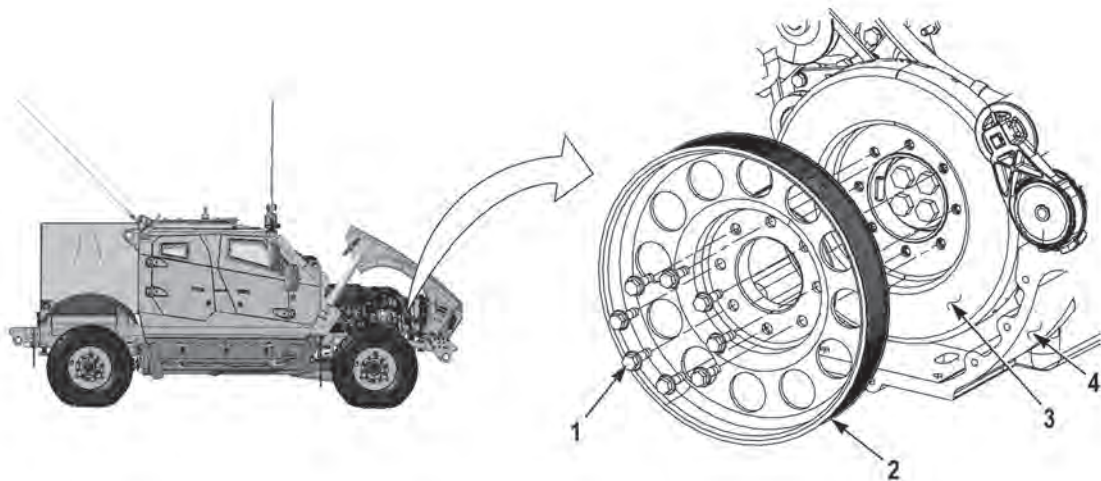

1. Remove eight screws (1), crank pulley (2), and harmonic balancer (3) from engine (4).

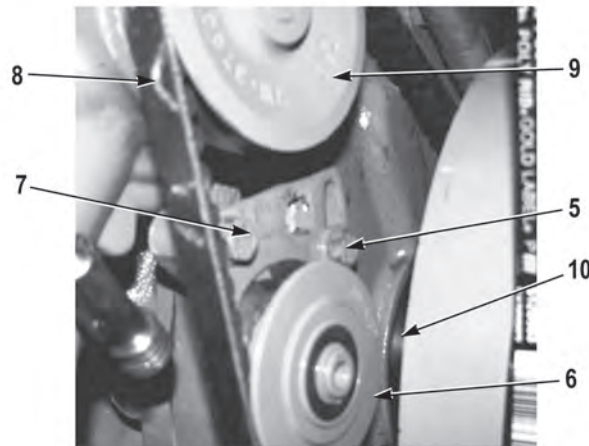

- Remove screw (5) from belt tensioner pulley (6).

### NOTE

Loosen screw enough to give play in belt tensioner pulley.

- Loosen screw (7) from belt tensioner pulley (6).
- Using a breaker bar, pivot belt tensioner pulley (6) upward to release tension of belt (8).

### NOTE

Note routing of belt prior to removal to ensure proper installation.

- Remove belt (8) from belt tensioner pulley (6), water pump pulley (9), and engine pulley (10).
- Remove breaker bar.

### END OF TASK

### INSTALLATION

### NOTE

Route belt as noted prior to removal.

- Install belt (8) on belt tensioner pulley (6), engine pulley (10), and water pump pulley (9).

### NOTE

Tighten screw enough to give play in belt tensioner pulley.

- Install but do not tighten screw (5) on belt tensioner pulley (6).
- Using a breaker bar, pivot belt tensioner pulley (6) downward to increase tension on belt (8) and tighten screw (5) on belt tensioner pulley (6). Tighten screw (5) to  $21 \pm 5$  lb-ft ( $28 \pm 7$  N•m).
- Tighten screw (7) on belt tensioner pulley (6). Tighten screw (7) to  $21 \pm 5$  lb-ft ( $28 \pm 7$  N•m).
- Remove breaker bar.

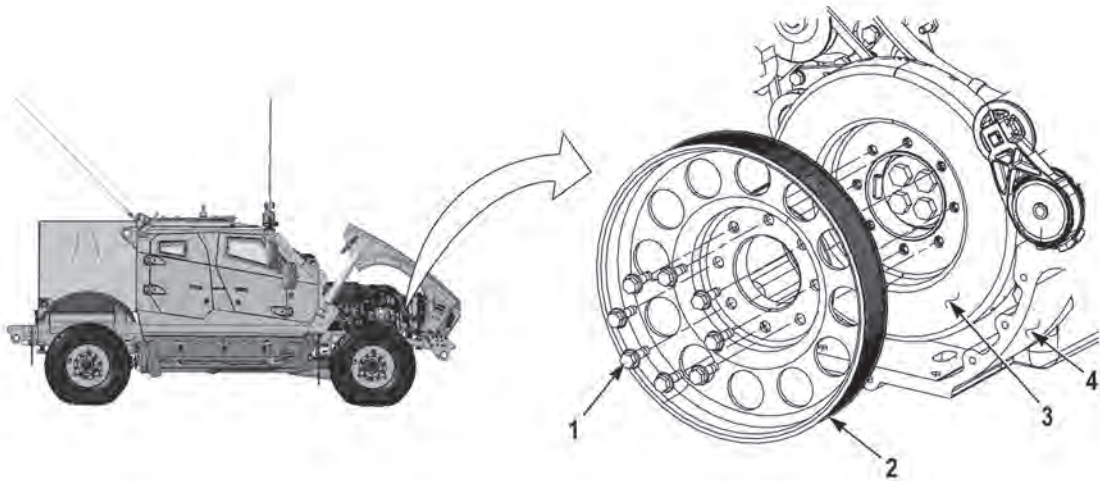

**WARNING**

Adhesives, solvents, and sealing compounds can burn easily, can give off harmful vapors, and are harmful to skin and clothing. To avoid injury or death, keep away from open fire and use in well-ventilated area. If adhesive, solvent, or sealing compound gets on skin or clothing, wash immediately with soap and water. Failure to comply may result in injury or death to personnel.

6. Apply sealing compound, Loctite 242, to threads of eight screws (1).
7. Install harmonic balancer (3) and crank pulley (2) on engine (4) with eight screws (1).
8. Perform all Follow-On Maintenance tasks.

**END OF TASK**

**END OF WORK PACKAGE**



---

**EXHAUST PIPE REPLACEMENT (M1240/M1245)**

---

**Preconditions**

Park vehicle  
 Engine OFF  
 Wheels chocked  
 Hood opened and secured  
 Passenger side engine panel removed (WP 0226)  
 Muffler removed (WP 0241)

**Tools and Special Tools**

Tool Kit, General Mechanic's: Automotive

**Materials/Parts**

Locknut (2) (Item 4 and 6)

**Personnel Required**

Two

**Follow-On Maintenance**

Install muffler (WP 0241)  
 Install passenger side engine panel (WP 0226)  
 Close hood and secure  
 Remove and stow wheel chocks

---

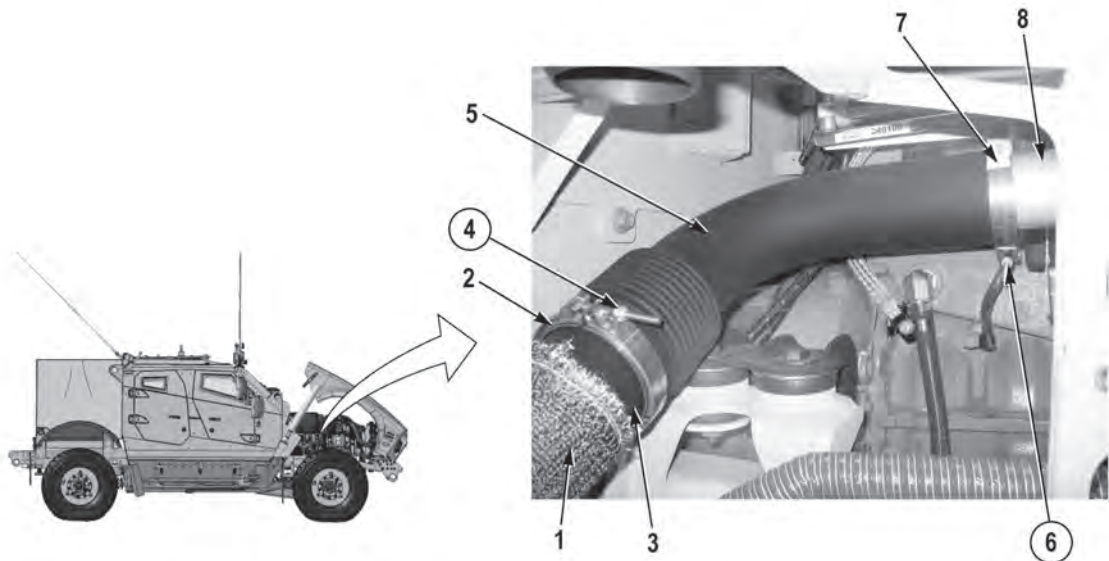
**REMOVAL****WARNING**

During vehicle operation exhaust system can become very hot. Do not touch exhaust system components with bare hands, or allow your body to come in contact with exhaust system components. Failure to comply may result in injury to personnel.

**NOTE**

- Exhaust sock will need to be pulled back to access clamps.
- Note position of clamps prior to removal to ensure proper installation.

1. Slide exhaust sock (1) away from clamp (2) and onto exhaust pipe (3).

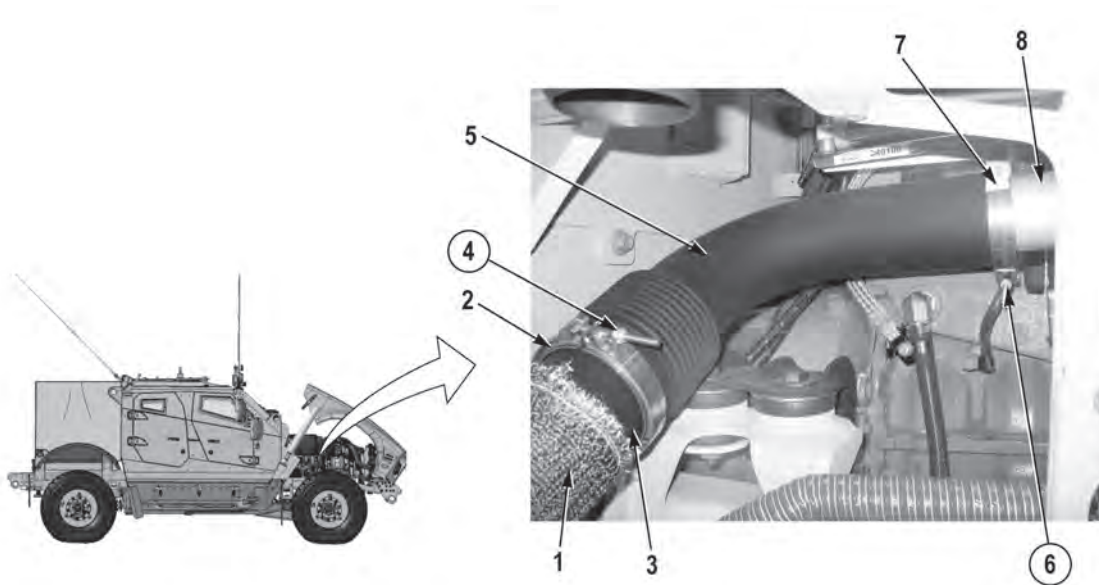

2. Remove locknut (4), clamp (2), and exhaust pipe (3) from exhaust pipe (5). Discard locknut (4).
3. Remove locknut (6), clamp (7), and exhaust pipe (5) from turbocharger (8). Discard locknut (6).

#### END OF TASK

#### INSTALLATION

#### NOTE

Install clamps and exhaust sock as noted prior to removal.

1. With the aid of an assistant, install exhaust pipe (5) on turbocharger (8) with clamp (7) and new locknut (6).
2. Install exhaust pipe (3) on exhaust pipe (5) with clamp (2) and new locknut (4).
3. Slide exhaust sock (1) over exhaust pipe (3).
4. Perform all Follow-On Maintenance tasks.

#### END OF TASK

#### END OF WORK PACKAGE

---

## EXHAUST PIPE REPLACEMENT (M1240A1)

---

**Preconditions**

Park vehicle  
 Engine OFF  
 Wheels chocked  
 Muffler removed (WP 0242)

**Tools and Special Tools**

Tool Kit, General Mechanic's: Automotive

**Materials/Parts**

Locknut (2) (Item 1)  
 Locknut (Item 13)

**Follow-On Maintenance**

Install muffler (WP 0242)  
 Remove and stow wheel chocks

---

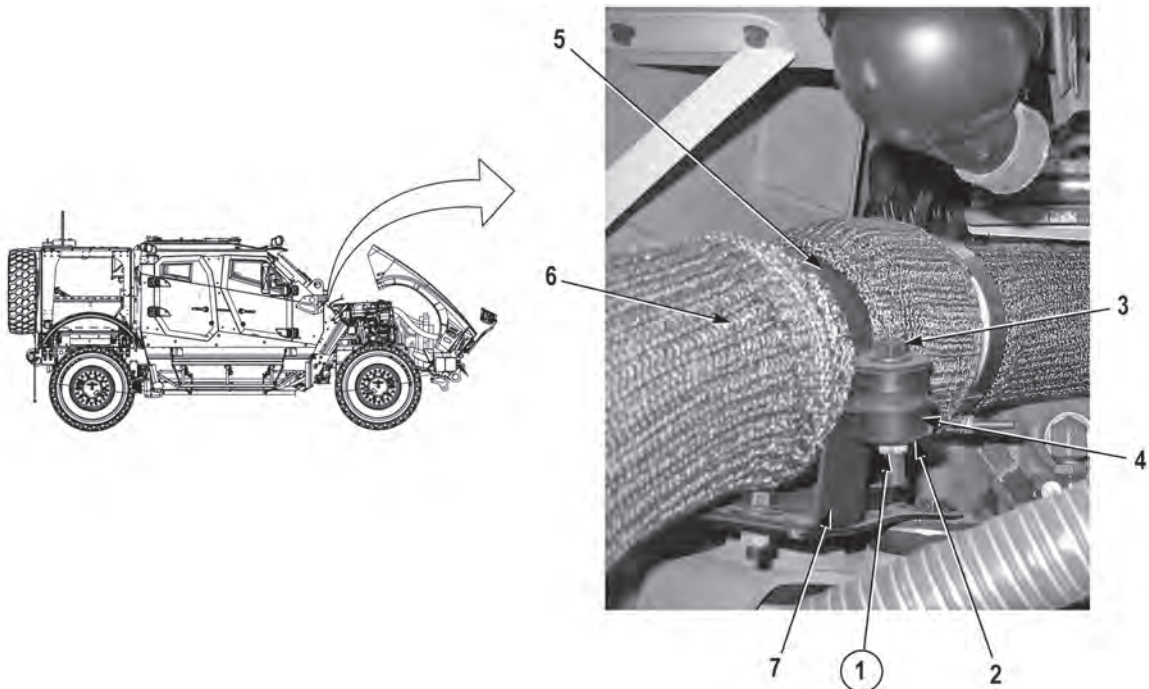
**REMOVAL****WARNING**

During vehicle operation exhaust system can become very hot. Do not touch exhaust system components with bare hands, or allow your body to come in contact with exhaust system components. Failure to comply may result in injury to personnel.

**NOTE**

Note position and orientation of hardware prior to removal to ensure proper installation.

1. Remove two locknuts (1), washers (2), screws (3), two-piece mounts (4), clamp (5), and exhaust pipe (6) from bracket (7). Discard locknuts (1).

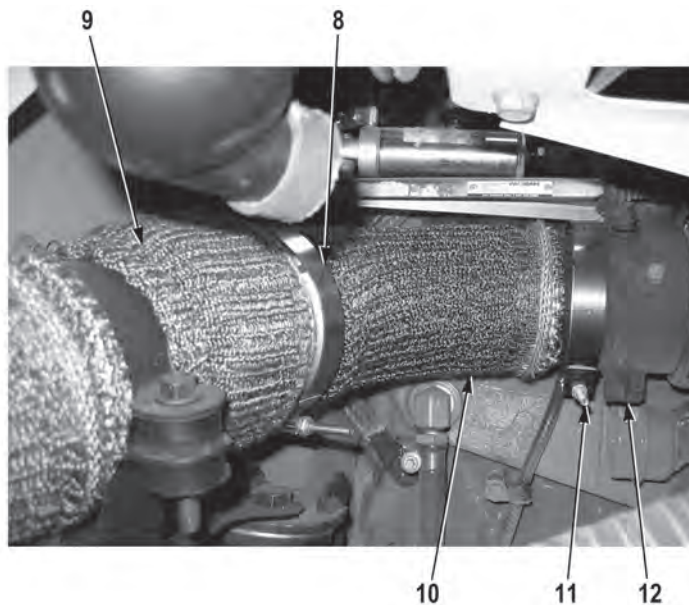

### NOTE

Note position of clamps prior to removal to ensure proper installation.

2. Loosen clamp (8) and remove exhaust pipe (9) from exhaust pipe (10).
3. Loosen clamp (11) and remove exhaust pipe (10) from turbocharger (12).

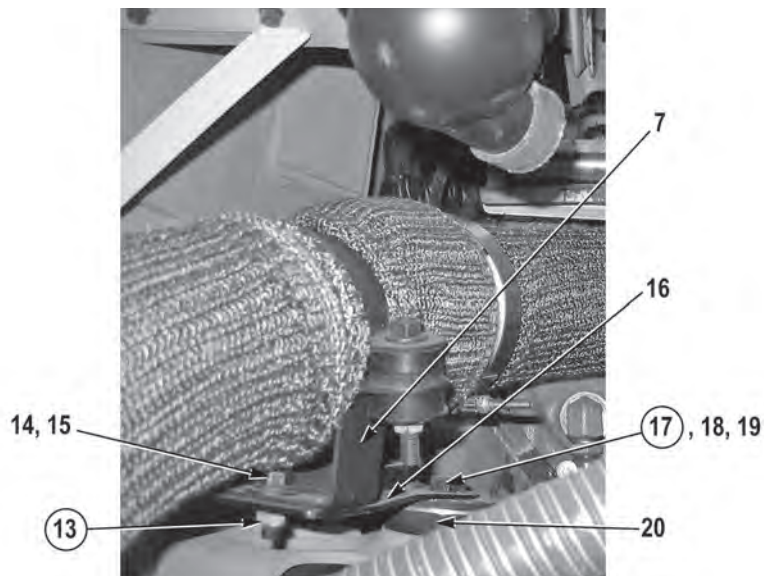

### NOTE

Perform Step (4) if brackets need to be removed.

4. Remove locknut (13), screw (14), two washers (15), and bracket (7) from bracket (16). Discard locknut (13).
5. Remove two locknuts (17), washers (18), screws (19), and bracket (16) from power train mount (20). Discard locknuts (17).



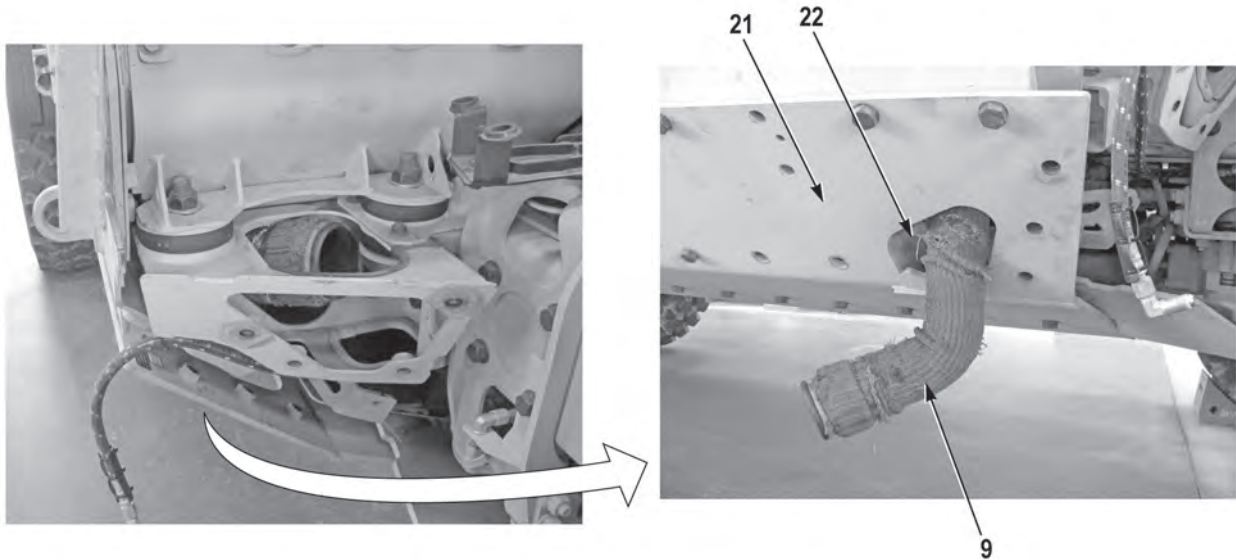

6. Rotate exhaust pipe (9) toward armor panel (21) and remove through armor panel (21) access hole (22).

#### END OF TASK

#### INSTALLATION

1. Install exhaust pipe (9) through access hole (22) while rotating through armor panel (21).

#### NOTE

Perform Step (2) if brackets were removed.

2. Install bracket (16) on power train mount (20) with two screws (19), washers (18), and new locknuts (17).
3. Install bracket (7) on bracket (16) with two washers (15), screw (14), and new locknut (13).

#### NOTE

Install clamps as noted prior to removal.

4. Install exhaust pipe (10) on turbocharger (12) with clamp (11).
5. Install exhaust pipe (9) on exhaust pipe (10) with clamp (8).

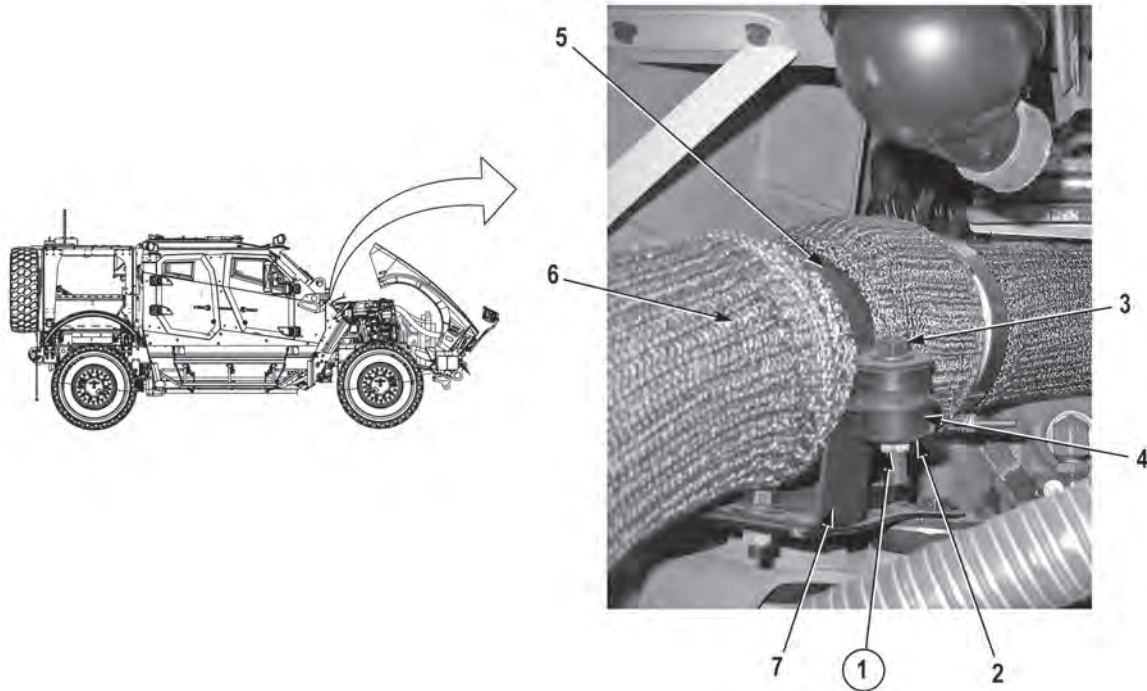
**NOTE**

Install hardware as noted prior to removal.

6. Install exhaust pipe (6) and clamp (5) on bracket (7) with two, two-piece mounts (4), screws (3), washers (2), and new locknuts (1).
7. Perform all Follow-On Maintenance tasks.

**END OF TASK**

**END OF WORK PACKAGE**

---

**MUFFLER REPLACEMENT (M1240/M1245)**

---

**Preconditions**

Park vehicle  
 Engine OFF  
 Wheels chocked

**Tools and Special Tools**

Rubber Mallet  
 Tool Kit, General Mechanic's: Automotive

**Materials/Parts**

Locknut (Item 4)  
 Locknut (4) (Item 7)

**Personnel Required**

Two

**Follow-On Maintenance**

Remove and stow wheel chocks

---

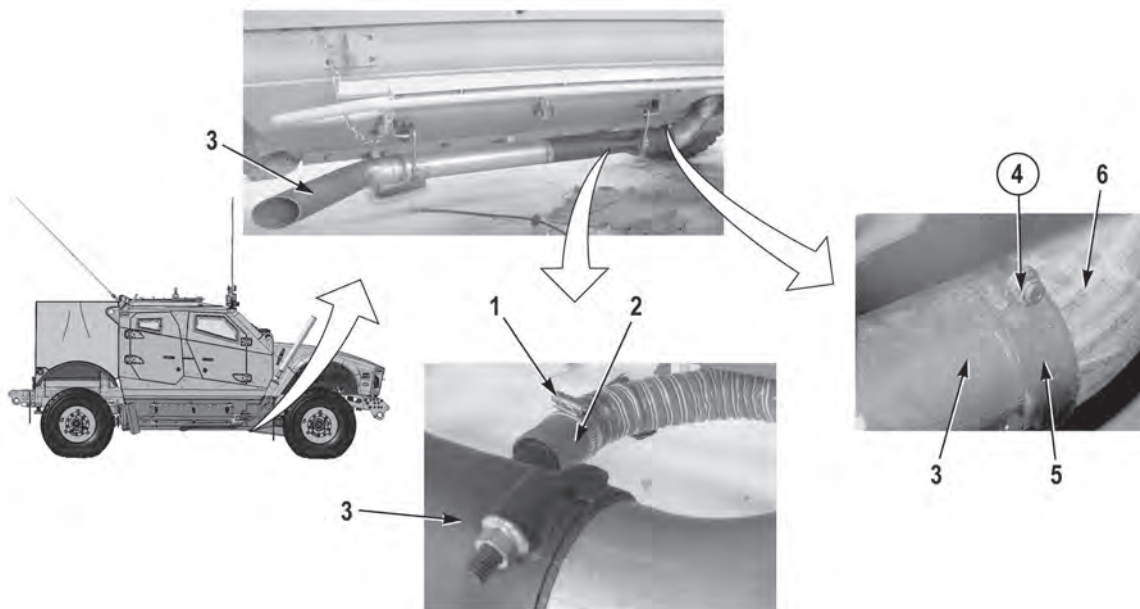
**REMOVAL****WARNING**

During vehicle operation exhaust system can become very hot. Do not touch exhaust system components with bare hands, or allow your body to come in contact with exhaust system components. Failure to comply may result in injury to personnel.

**NOTE**

May have to use a rubber mallet to break exhaust pipe loose.

1. Loosen clamp (1) and remove hose (2) from muffler (3).
2. Remove locknut (4) and slide clamp (5) away from muffler (3) and onto exhaust pipe (6). Discard locknut (4).

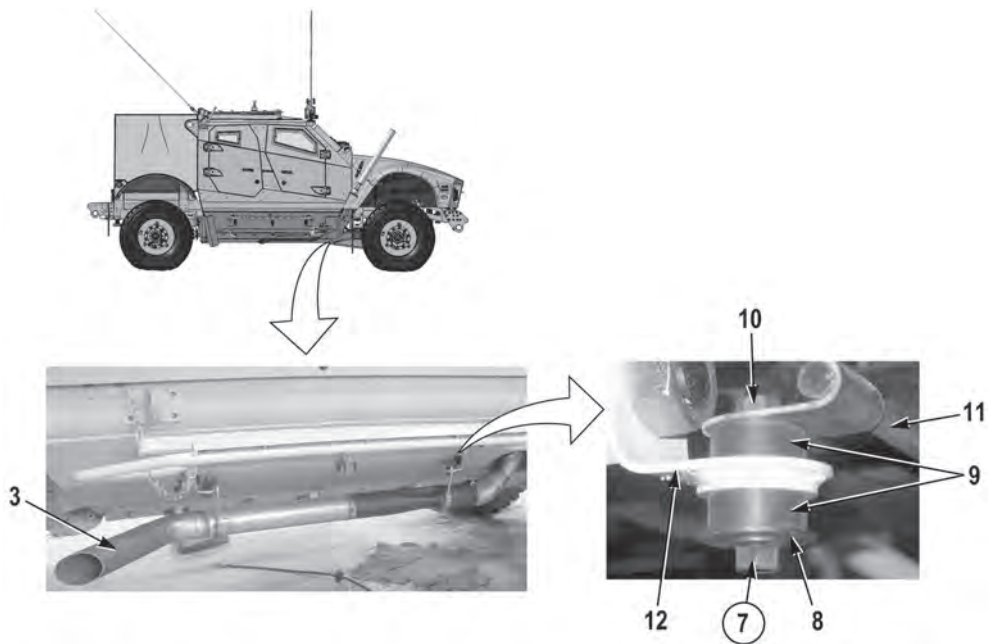
**NOTE**

A mount set consists of a male and female mount.

3. With the aid of an assistant, remove four locknuts (7), washers (8), mount sets (9), screws (10), brackets (11), and muffler (3), from four brackets (12). Discard locknuts (7).

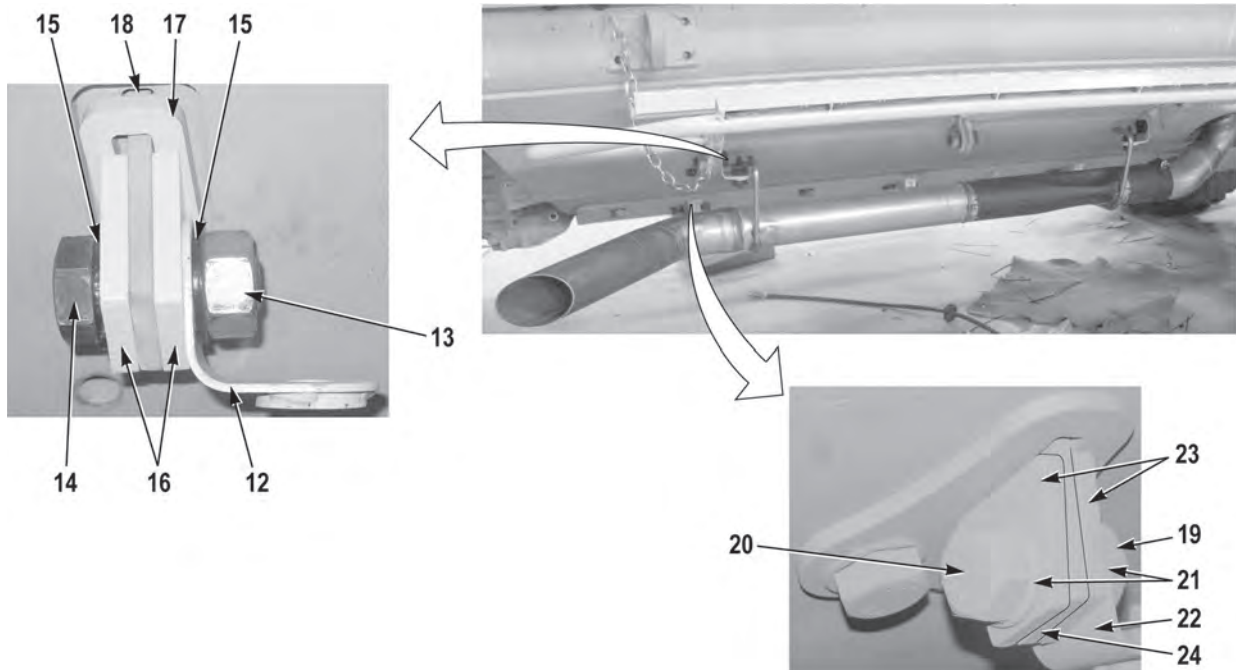

4. Remove two nuts (13), screws (14), four washers (15), two brackets (12), four wedges (16), and two spacers (17) from top armor mounting brackets (18).
5. Remove two nuts (19), screws (20), four washers (21), two brackets (22), and four wedges (23) from bottom armor mounting brackets (24).

#### END OF TASK

#### INSTALLATION

1. Install two brackets (22) on bottom armor mounting brackets (24) with four wedges (23), washers (21), two screws (20), and nuts (19).
2. Install two brackets (12), on top armor mounting brackets (18), with two spacers (17), four wedges (16), washers (15), two screws (14), and nuts (13).

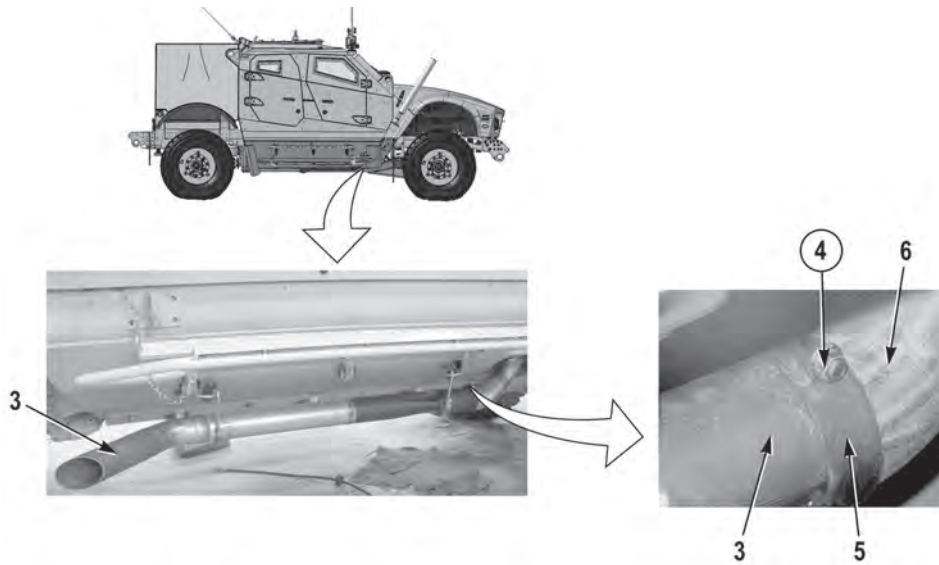

**NOTE**

Install clamps as noted prior to removal.

3. With the aid or an assistant, install muffler (3) on exhaust pipe (6) with clamp (5) and new locknut (4).

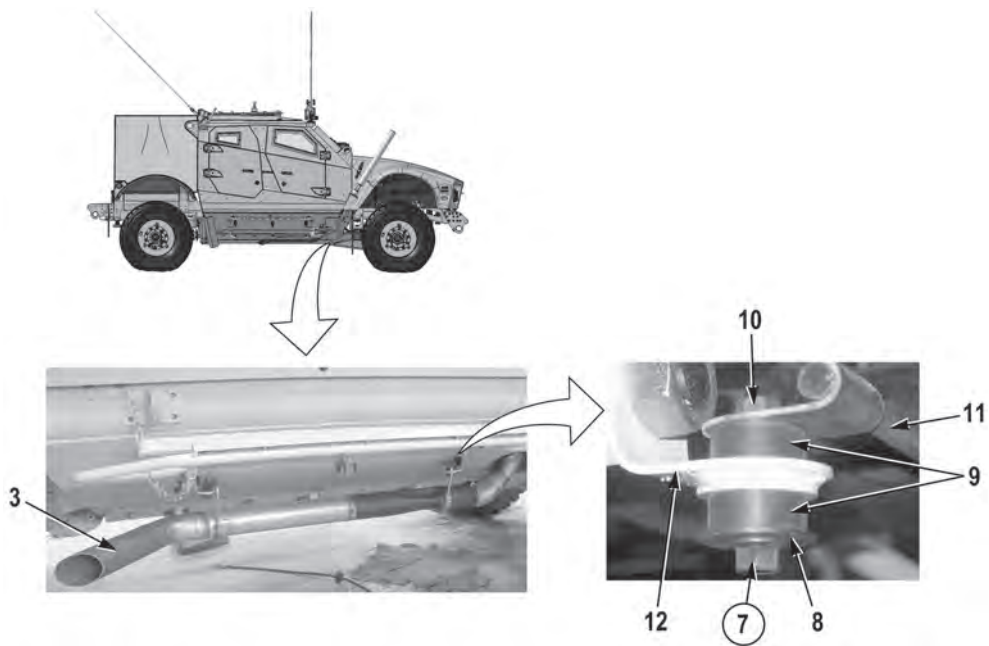

**NOTE**

Mount sets consist of a male and a female mount.

4. Install four brackets (11), on brackets (12), with screws (10), mount sets (9), eight washers (8), and four new locknuts (7).



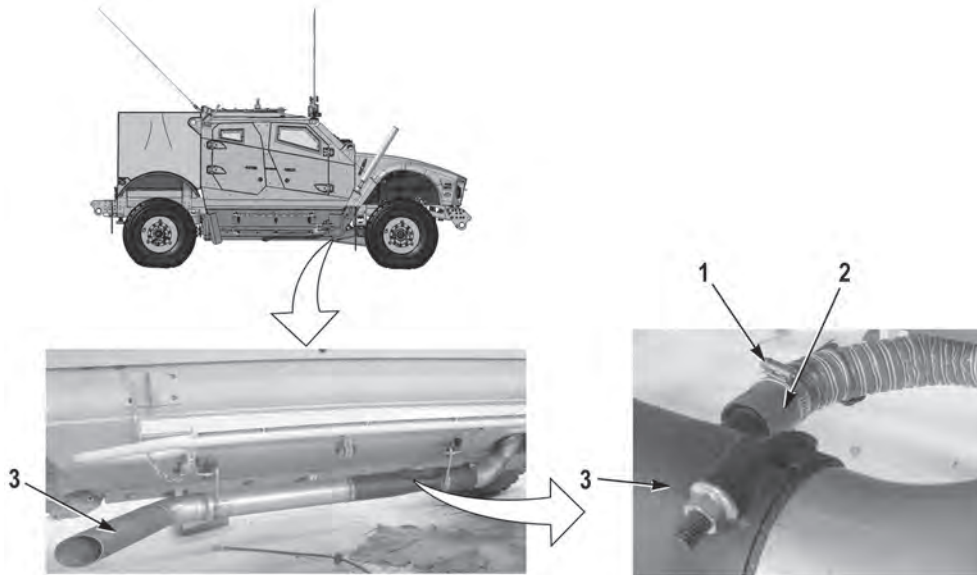

5. Install hose (2) on muffler (3) with clamp (1).
6. Perform all Follow-On Maintenance tasks.

**END OF TASK**

**END OF WORK PACKAGE**



---

**MUFFLER REPLACEMENT (M1240A1)**

---

**Preconditions**

Park vehicle  
 Engine OFF  
 Wheels chocked  
 Passenger side front wheel well deflector panel removed (M1240A1) (WP 0057)

**Tools and Special Tools**

Breaker Bar, 3/4 in.  
 Socket, 3/4 in. Dr. 36 mm  
 Tool Kit, General Mechanic's: Automotive

**Materials/Parts**

Locknut (4) (Item 7)  
 Compound, Sealing, Loctite 242

**Personnel Required**

Two

**Follow-On Maintenance**

Install passenger side front wheel well deflector panel (M1240A1) (WP 0057)  
 Remove and stow wheel chocks

---

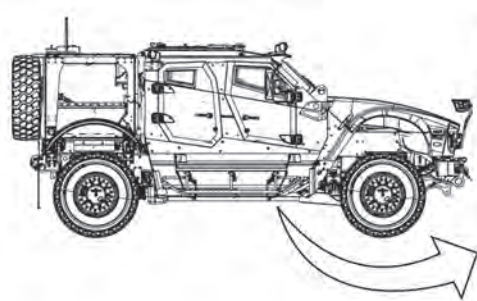
**REMOVAL**

COMPONENTS REMOVED  
 FOR CLARITY

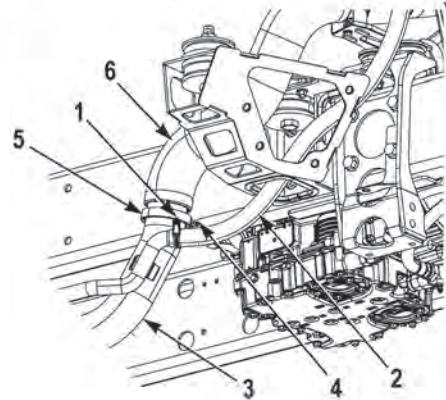
**WARNING**

During vehicle operation exhaust system can become very hot. Do not touch exhaust system components with bare hands, or allow your body to come in contact with exhaust system components. Failure to comply may result in injury to personnel.

1. Loosen clamp (1) and remove hose (2) from muffler (3).
2. Remove nut (4) and clamp (5) from exhaust pipe (6) and muffler (3).

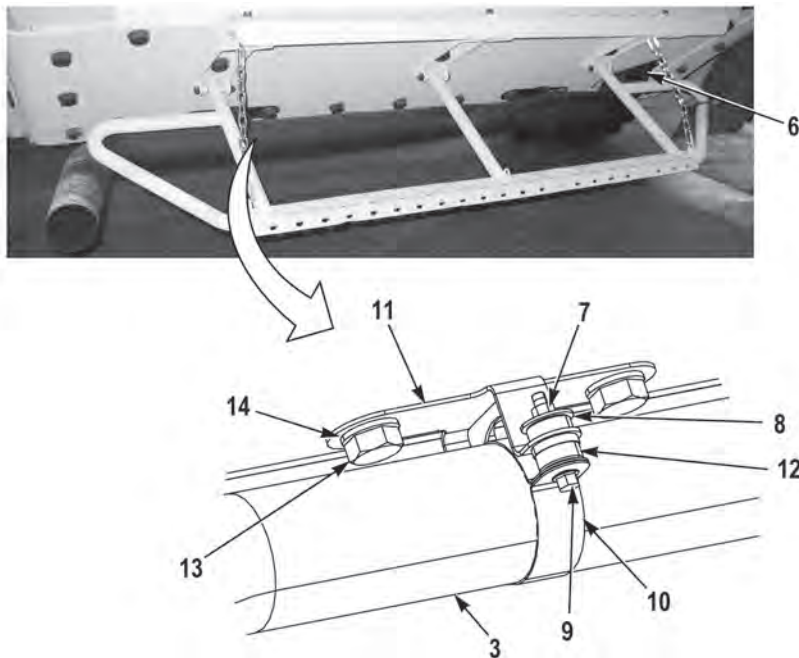

### NOTE

- Front and rear brackets are removed the same way. Rear bracket shown.
  - Note position and orientation of hardware prior to removal to ensure proper installation.
3. With the aid of an assistant, remove four locknuts (7), washers (8), screws (9), clamp halves (10), and muffler (3) from two brackets (11) and exhaust pipe (6). Discard locknuts (7).

### NOTE

Note position of two-piece bushing prior to removal to ensure proper installation.

4. Remove four rubber bushings (12) from two brackets (11).

### NOTE

Perform Step (5) if brackets need to be removed.

5. Remove four screws (13), washers (14), and two brackets (11) from vehicle.

## END OF TASK

## INSTALLATION

### WARNING

Adhesives, solvents, and sealing compounds can burn easily, can give off harmful vapors, and are harmful to skin and clothing. To avoid injury or death, keep away from open fire and use in well-ventilated area. If adhesive, solvent, or sealing compound gets on skin or clothing, wash immediately with soap and water. Failure to comply may result in injury or death to personnel.

**NOTE**

- Front and rear brackets are installed the same way. Rear bracket shown.
- Install hardware as noted prior to removal.
- Perform Steps (1) and (2) if brackets were removed.

1. Apply sealing compound, Loctite 242, to threads of four screws (13).
2. Install two brackets (11) on vehicle with four washers (14) and screws (13).

**NOTE**

Install two-piece bushing as noted prior to removal.

3. Install four rubber bushings (12) on two brackets (11).

**NOTE**

Turbo and exhaust clamps may need to be loosened to achieve alignment of muffler.

4. Install muffler (3) on exhaust pipe (6) with clamp (5) and nut (4).

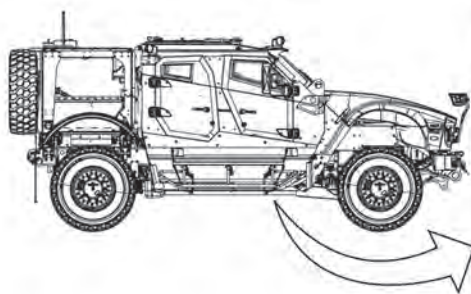

**COMPONENTS REMOVED  
FOR CLARITY**

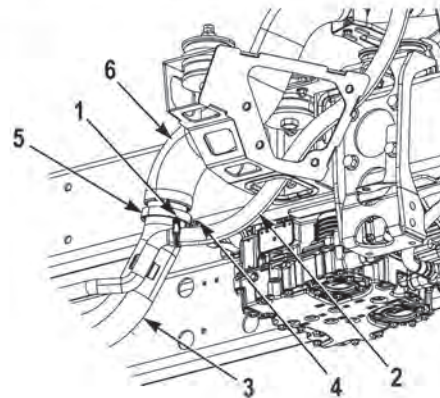

5. With the aid of an assistant, install muffler (3) on two brackets (11) with four clamp halves (10), screws (9), washers (8), and new locknuts (7).
6. Install hose (2) on muffler (3) with clamp (1).
7. Perform all Follow-On Maintenance tasks.

**END OF TASK**

**END OF WORK PACKAGE**





---

**CARGO DECK REPLACEMENT (M1245)**

---

**Preconditions**

Park vehicle  
 Engine OFF  
 Wheels chocked  
 Batteries Disconnected (WP 0187)  
 Spare Tire Carrier Removed (WP 0043)  
 GFE Cabinets Removed (WP 0252)  
 Rear Cargo Doors Removed (WP 0248)  
 Litter Doors Removed (WP 0245)  
 Battery PDU Disconnected (WP 0190)  
 Quick lock Floor Removed (WP 0254)

**Tools and Special Tools**

Lifting Device  
 Tool Kit, General Mechanic's: Automotive  
 Sling Assembly (NSN # 3940-01-209-6008)  
 Torque Wrench 20-100 ft-lb

**Materials/Parts**

Locknut (1) (Item 14)  
 Locknut (2) (Item 21)

**Materials/Parts (continued)**

Locknut (2) (Item 43)  
 Locknut (1) (Item 46)  
 Locknut (3) (Item 50)  
 Locknut (2) (Item 61)  
 Locknut (8) (Item 76)  
 Rubber Strip (2) (Item 83)  
 Tags, Identification  
 Ties, Cable

**Personnel Required**

Two

**Follow-On Maintenance**

Install Quick lock Floor (WP 0254)  
 Connect Battery PDU (WP 0190)  
 Install Litter Doors (WP 0245)  
 Install Rear Cargo Doors (WP 0248)  
 Install GFE Cabinets (WP 0252)  
 Install Tire Carrier (WP 0043)  
 Connect Batteries (WP 0187)  
 Remove and Stow Wheel Chocks

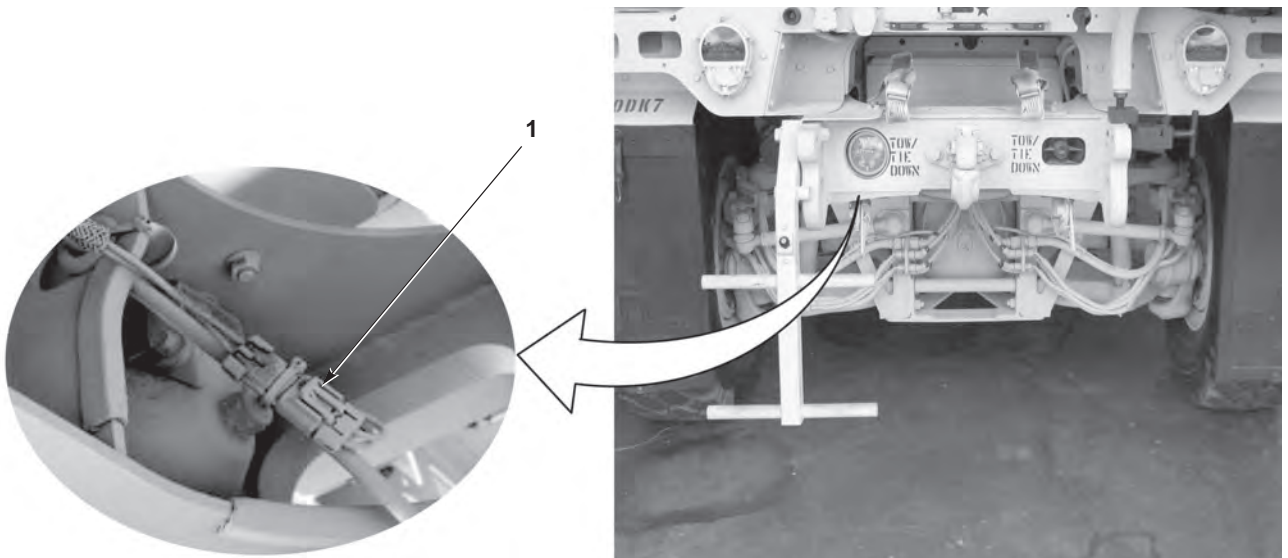
**REMOVAL****NOTE**

- Tag and mark wires and connectors prior to removal to ensure proper installation.
- Remove cable ties as required.

1. Disconnect connector (1).

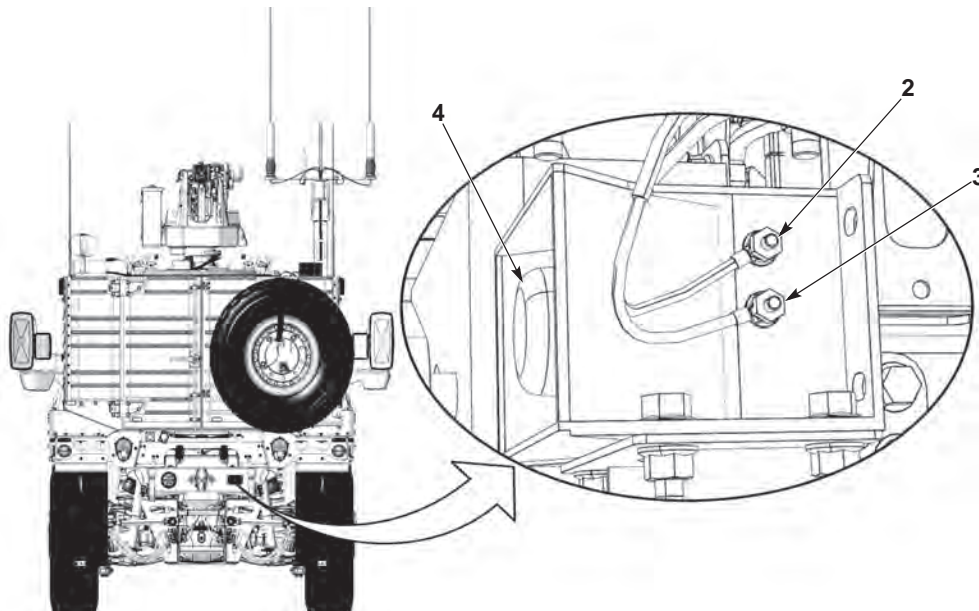
**REMOVAL – CONTINUED****NOTE**

- Tag and mark wires and connectors and note all wire harness routing prior to removal to ensure proper installation.
  - Remove cable ties as required.
2. Remove connectors (2 and 3), from the backup alarm (4).

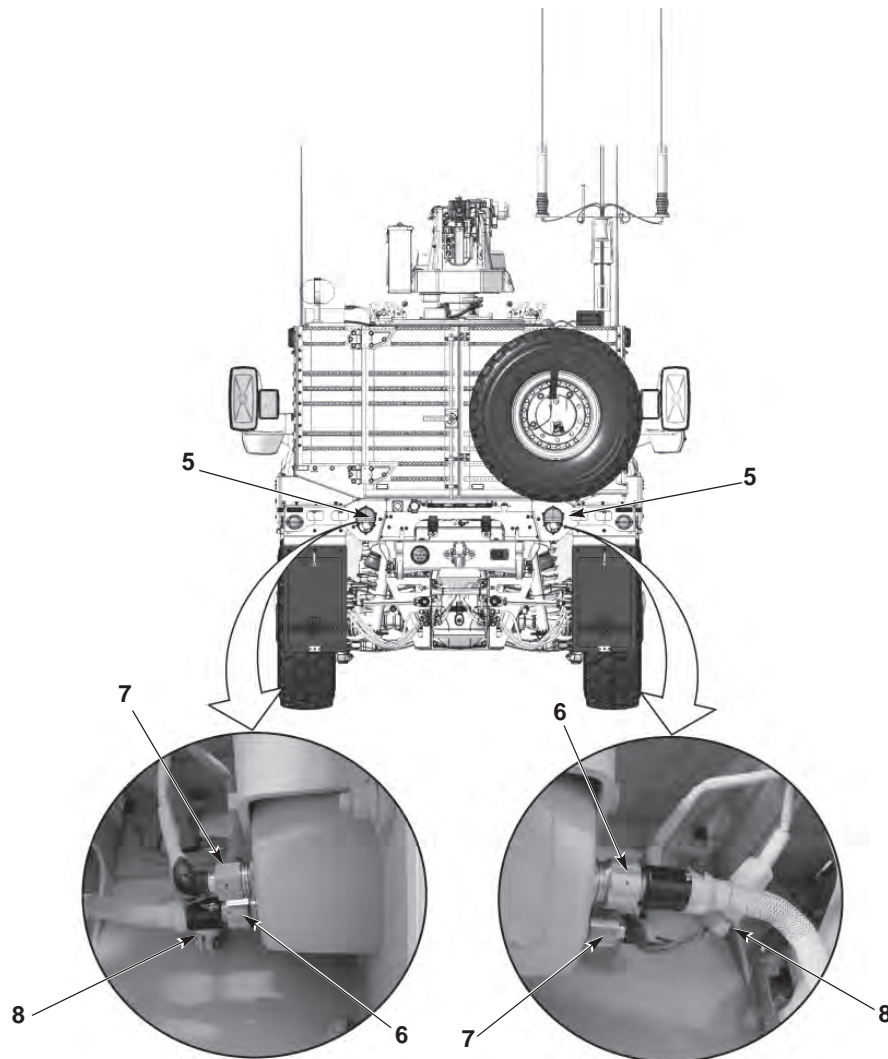
**REMOVAL – CONTINUED****NOTE**

- Tag and mark wires and connectors and note all wire harness routing prior to removal to ensure proper installation.
  - Remove cable ties as required.
3. Disconnect connectors (6, 7 and 8) from drivers side and passenger side backup lights (5).
  4. Route cables through cargo deck.

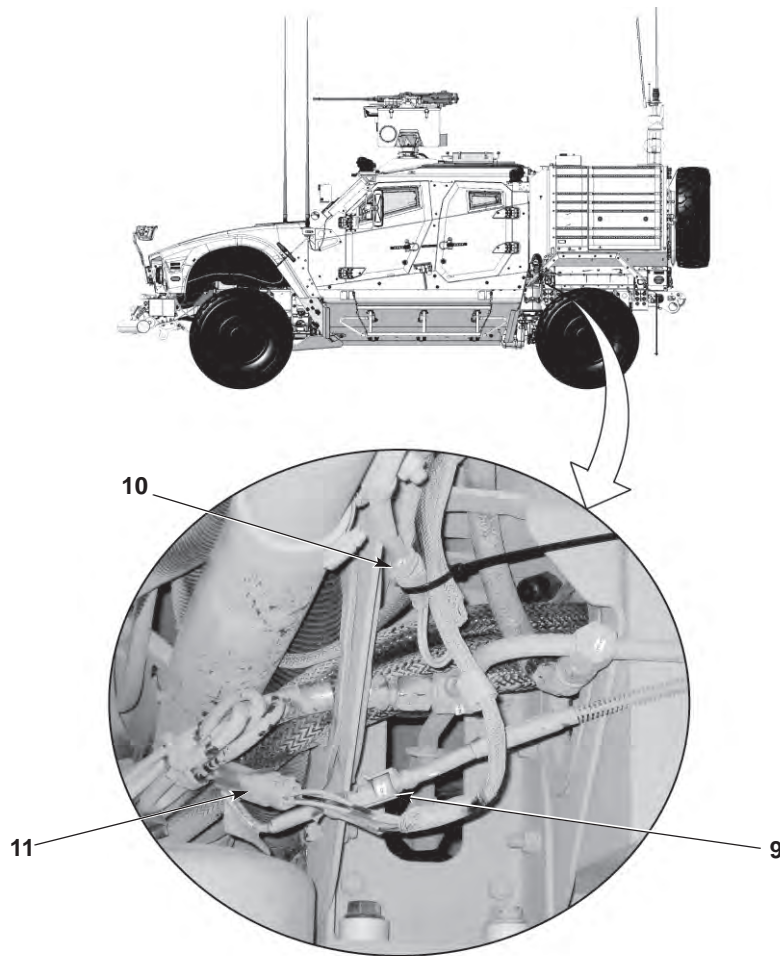
**REMOVAL – CONTINUED****NOTE**

- Tag and mark wires and connectors and note all wire harness routing prior to removal to ensure proper installation.
  - Remove cable ties as required.
5. Disconnect wire connector LOC1 (9) and wire connector LOC3 (10).
  6. Disconnect wire connector LOC1 (11).

## REMOVAL – CONTINUED

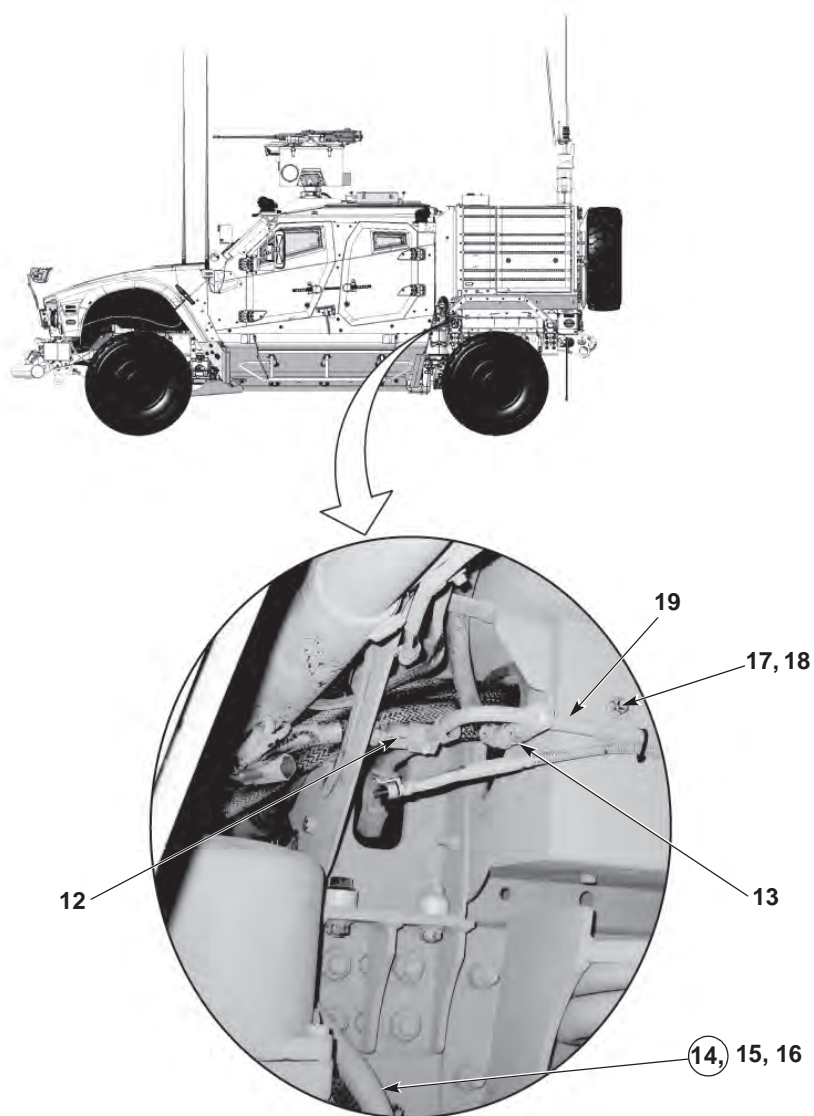
**NOTE**

- Tag and mark hose connectors and note all routing prior to removal to ensure proper installation.
  - Remove cable ties as required.
7. Disconnect the fire suppression disbursement hose (12).
  8. Disconnect the fire suppression disbursement hose (13).
  9. Remove locknut (14) and washer (15) from the grounding strap (16). Discard locknut (14).
  10. Remove nut (17) and washer (18) from the front section of the fire suppression disbursement rail (19).

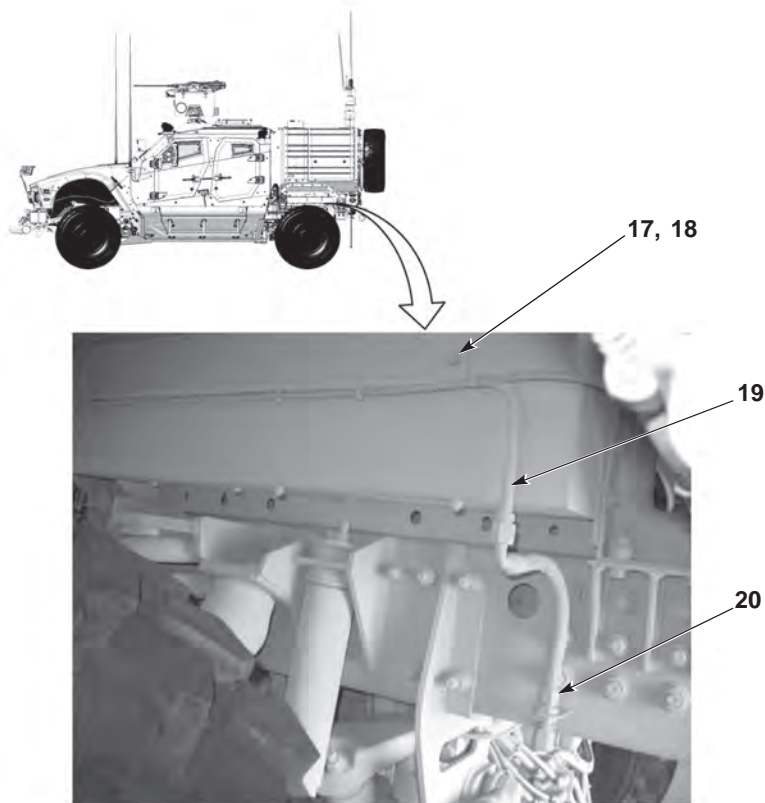
**REMOVAL – CONTINUED****NOTE**

Remove cable ties as required.

11. Disconnect the fire suppression disbursement hose (20), from the fire suppression disbursement rail (19) and remove disbursement rail.
12. Remove nut (17) and washer (18) from the rear section of the fire suppression disbursement rail (19).

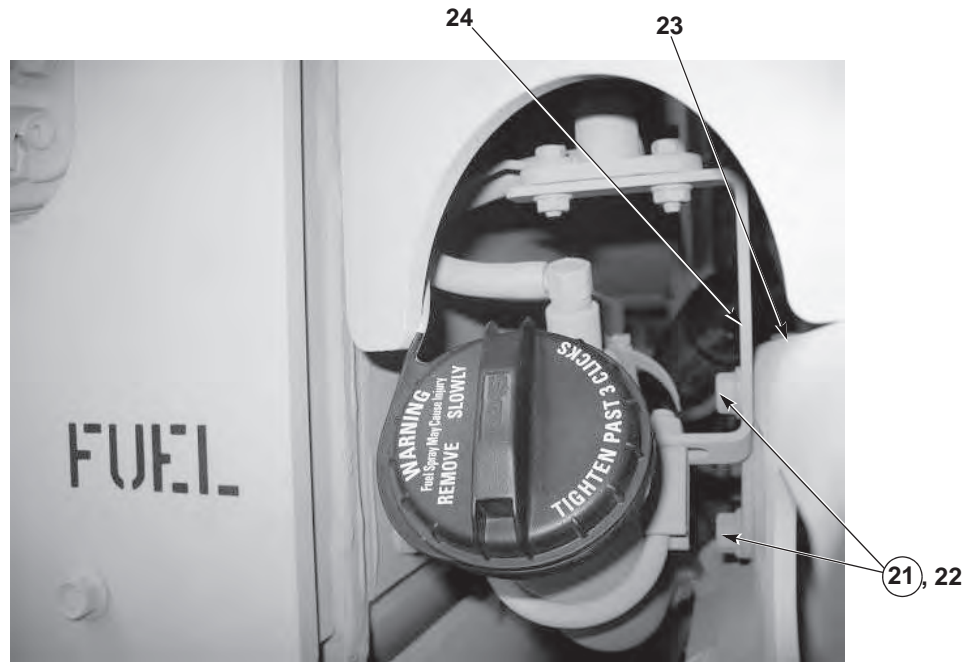

## REMOVAL – CONTINUED

**WARNING**

**Fuel is flammable and can explode. Keep fuel away from open flame and keep fire extinguisher within easy reach when working with fuel. Do not work on fuel system when engine is hot. Fuel can be ignited by hot engine. Smoking is prohibited while working with fuel. Failure to comply may result in injury or death to personnel.**

13. Remove two locknuts (21), screws (22), from cargo deck (23). Discard locknuts (21).
14. Remove fuel filler tube assembly bracket (24) from cargo deck (23).

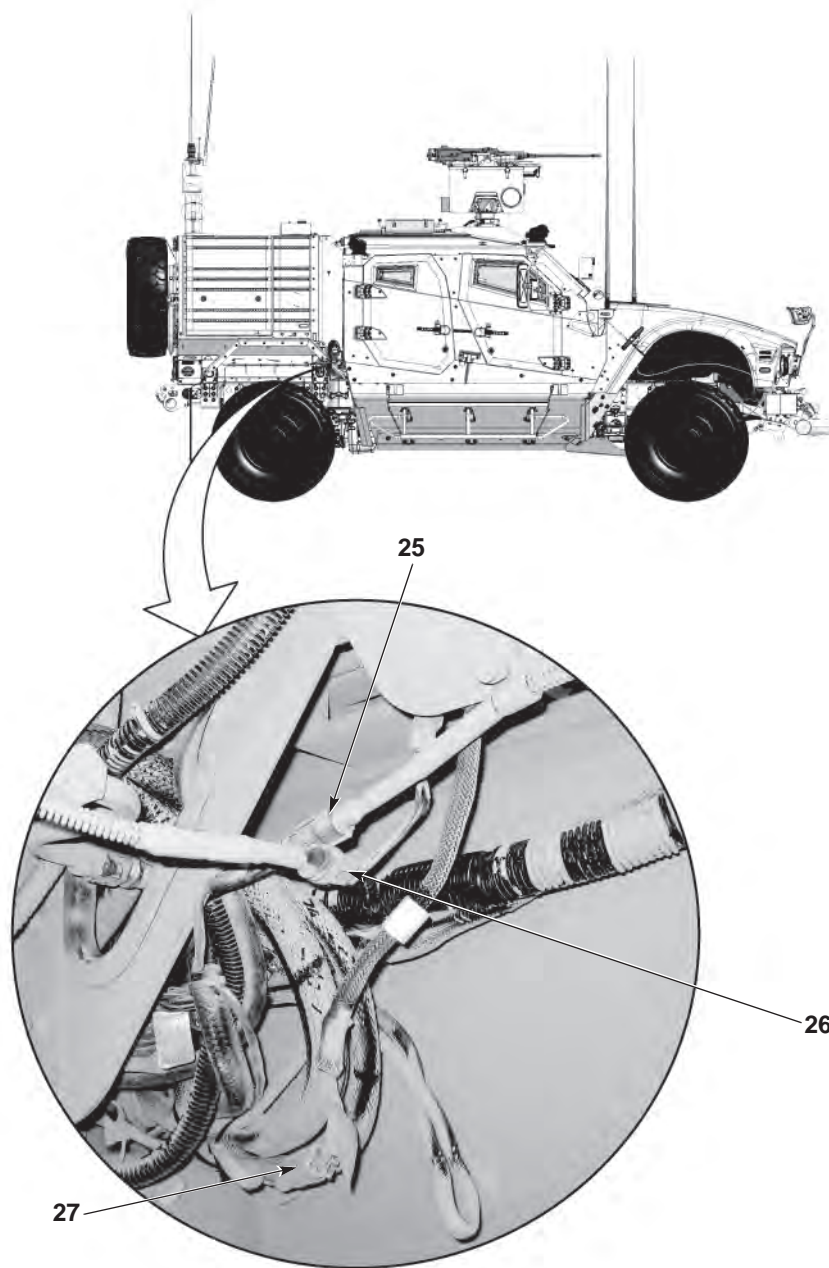
**REMOVAL – CONTINUED****NOTE**

- Tag and mark wires and connectors and note all wire harness routing prior to removal to ensure proper installation.
- Remove cable ties as required.

15. Disconnect wire connector LOC1 (25) and wire connector LOC3 (26).

16. Disconnect wire connector LOC1 (27).

## REMOVAL – CONTINUED

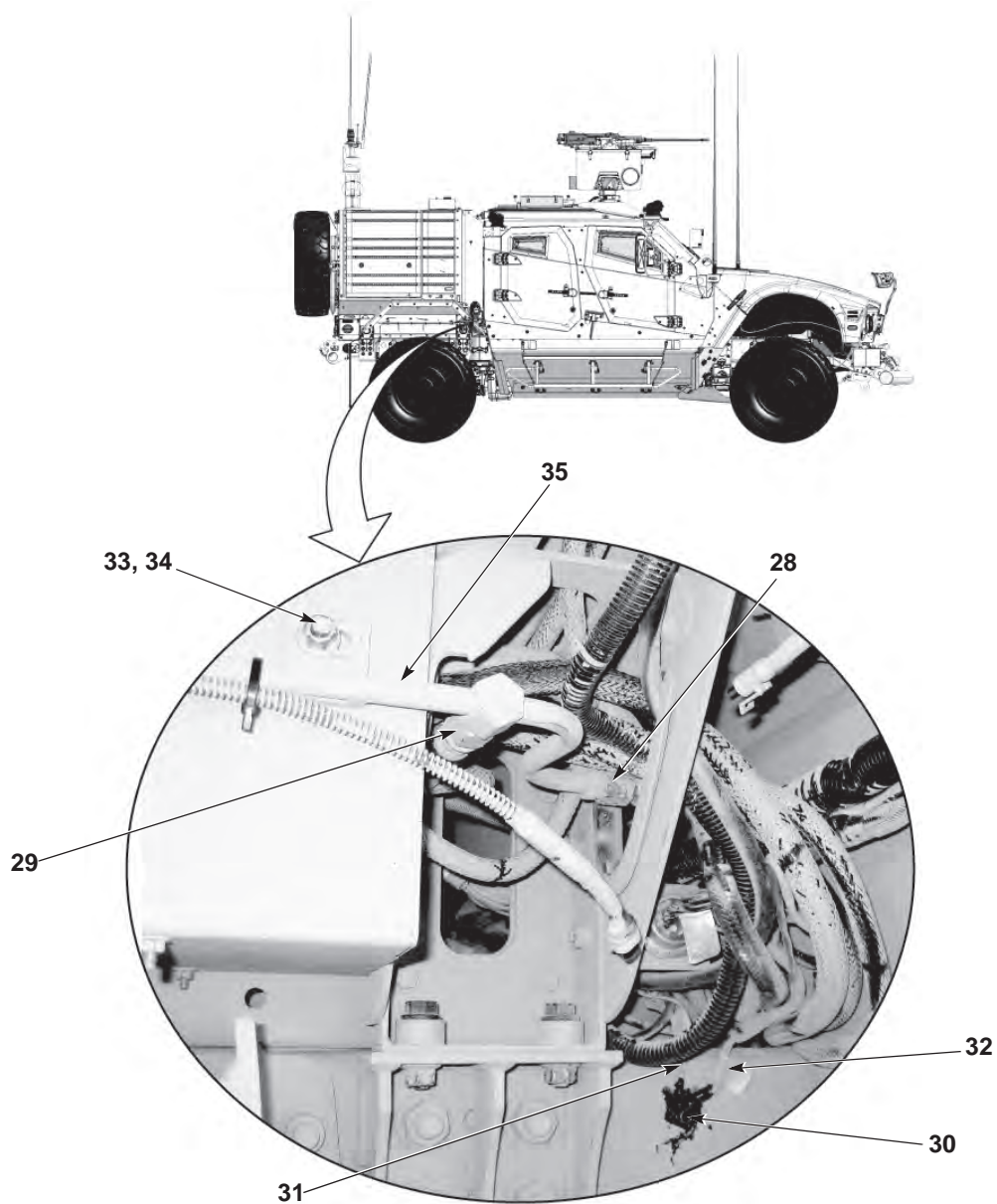
**NOTE**

- Tag and mark hose connectors and note all routing prior to removal to ensure proper installation.
- Remove cable ties as required.

17. Disconnect the fire suppression disbursement hose (28).
18. Disconnect the fire suppression disbursement hose (29).
19. Remove screw (30) from the grounding wires (31 and 32).
20. Remove nut (33) and washer (34) from the front section of the fire suppression disbursement rail (35).

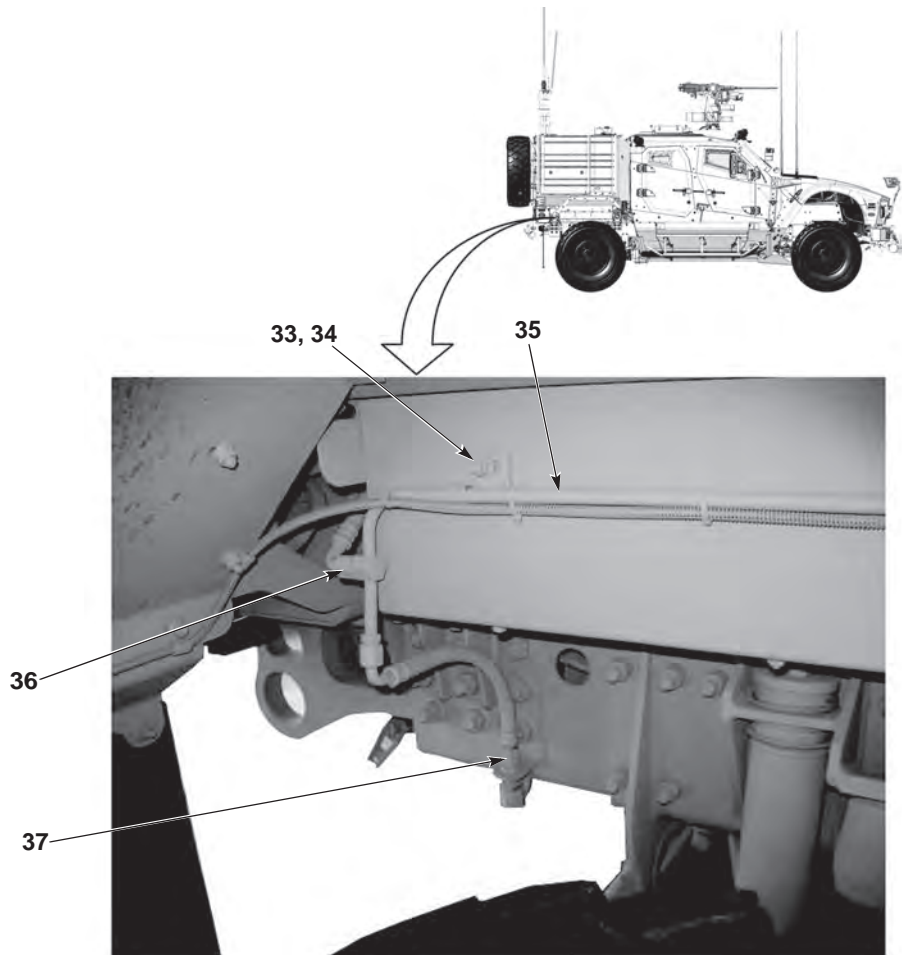
**REMOVAL – CONTINUED****NOTE**

Remove cable ties as required.

21. Disconnect the fire suppression disbursement hose (36), from the fire suppression disbursement rail (35).
22. Disconnect the fire suppression disbursement hose (37), from the fire suppression disbursement rail (35) and remove disbursement rail.
23. Remove nut (33) and washer (34) from the rear section of the fire suppression disbursement rail (35).

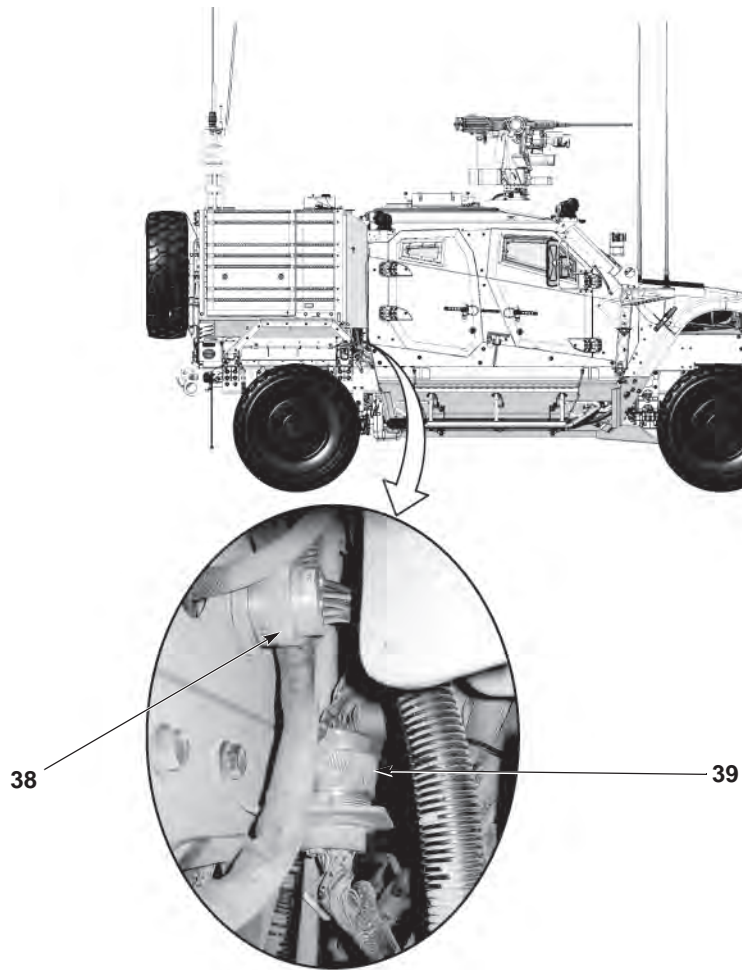
**REMOVAL – CONTINUED****NOTE**

- Tag and mark hose connectors and note all routing prior to removal to ensure proper installation.
- Remove cable ties as required.

24. Disconnect cannon plug (38) and cannon plug (39).

## REMOVAL – CONTINUED

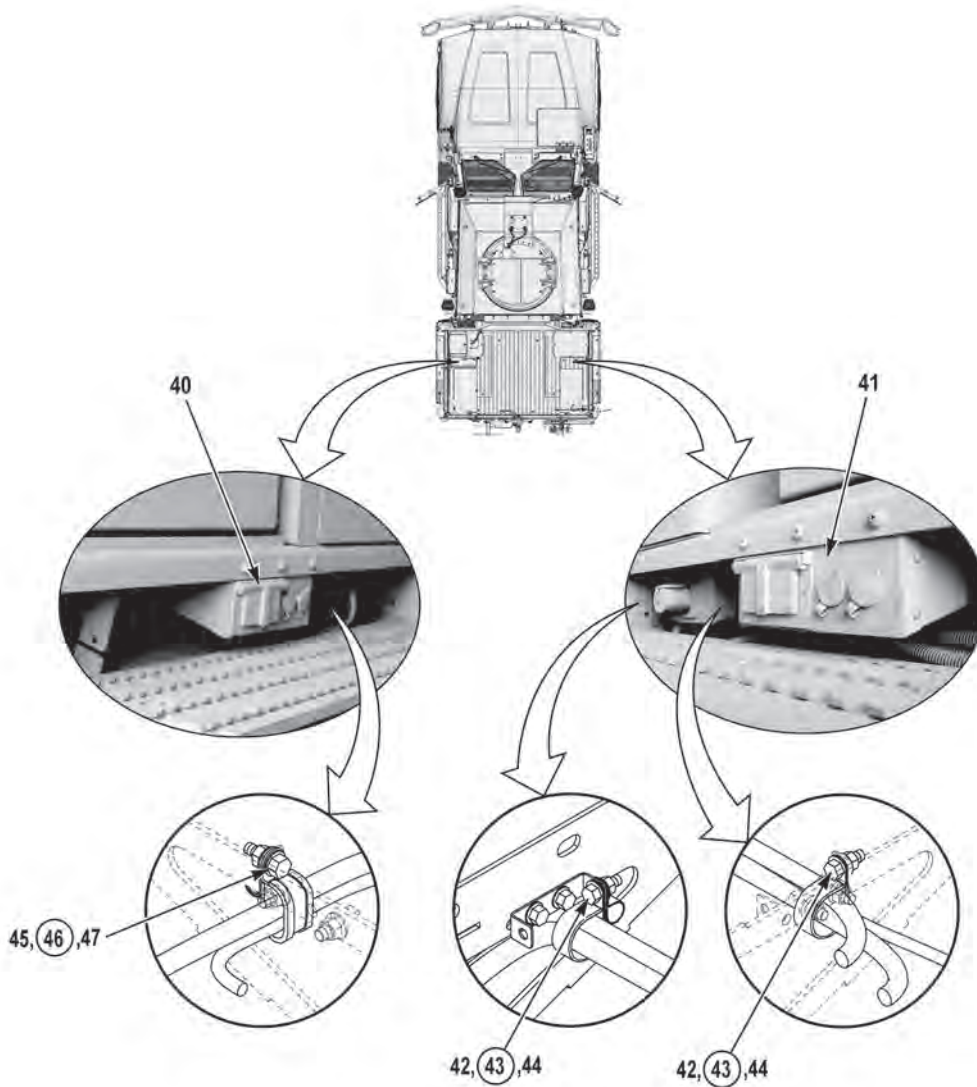
**NOTE**

- Tag and mark wires and connectors and note all wire harness routing prior to removal to ensure proper installation.
- Remove cable ties and cushion clips as required.

25. Disconnect the wire harnesses on passenger side power outlets (41).
26. Remove two screws (42), two locknuts (43), and two cushion clips (44) from the wire harness. Discard locknuts (43).
27. Disconnect the wire harnesses on driver side power outlets (40).
28. Remove screw (45), locknut (46), and cushion clip (47) from the wire harness. Discard locknut (46).

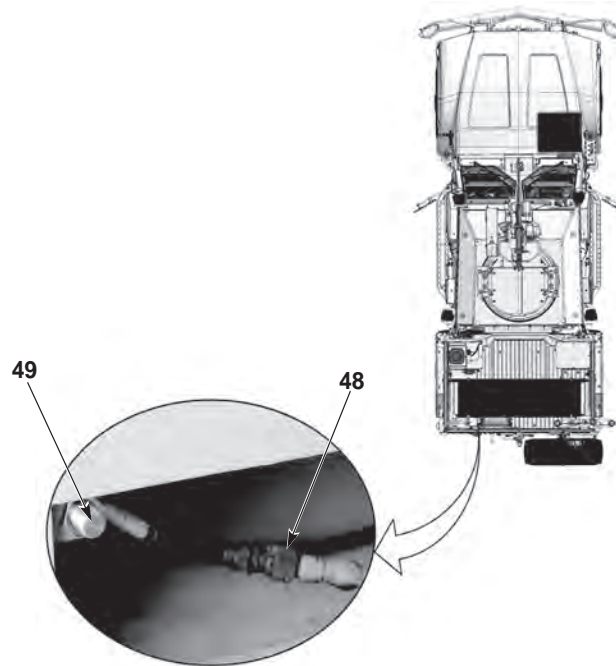

**REMOVAL – CONTINUED****NOTE**

- Tag and mark wires and connectors and note all wire harness routing prior to removal to ensure proper installation.
- Remove cable ties as required.

29. Disconnect the wire harness (48) on the cargo door proximity switch (49).

## REMOVAL – CONTINUED

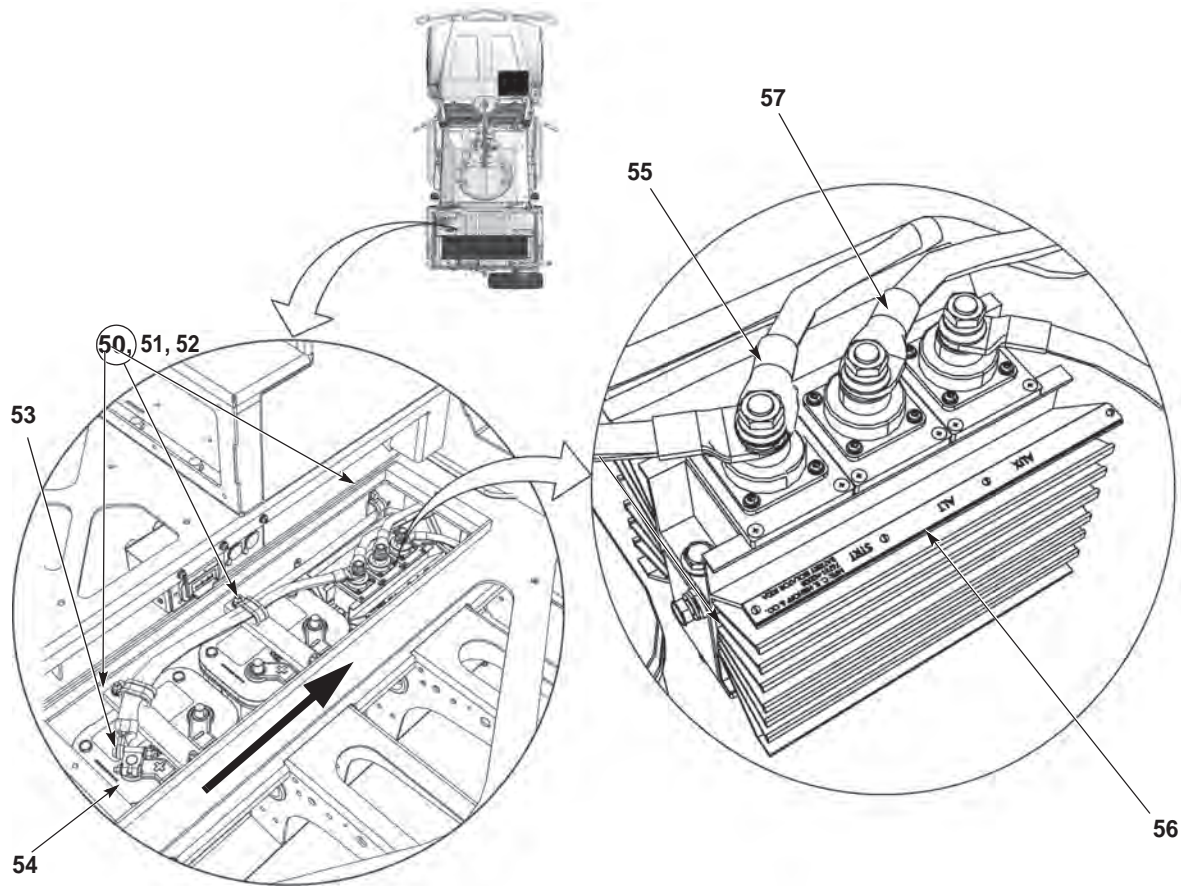
**NOTE**

- As a precondition, the batteries are disconnected by disconnecting the negative battery cables **ONLY**. The following procedure is for disconnecting the remaining battery cables.
- Tag and mark all cables and connectors, note all routing prior to removal to ensure proper installation.

30. On the drivers side of the cargo deck, remove three locknuts (50) and three washers (51) from the cable clamps (52). Discard locknuts (50).
31. Disconnect 3904931 battery cable (53) from the drivers side rear battery (54).
32. Disconnect cable (55) from STRT terminal on battery isolator (56).
33. Disconnect cable (57) from ALT terminal on battery isolator (56).

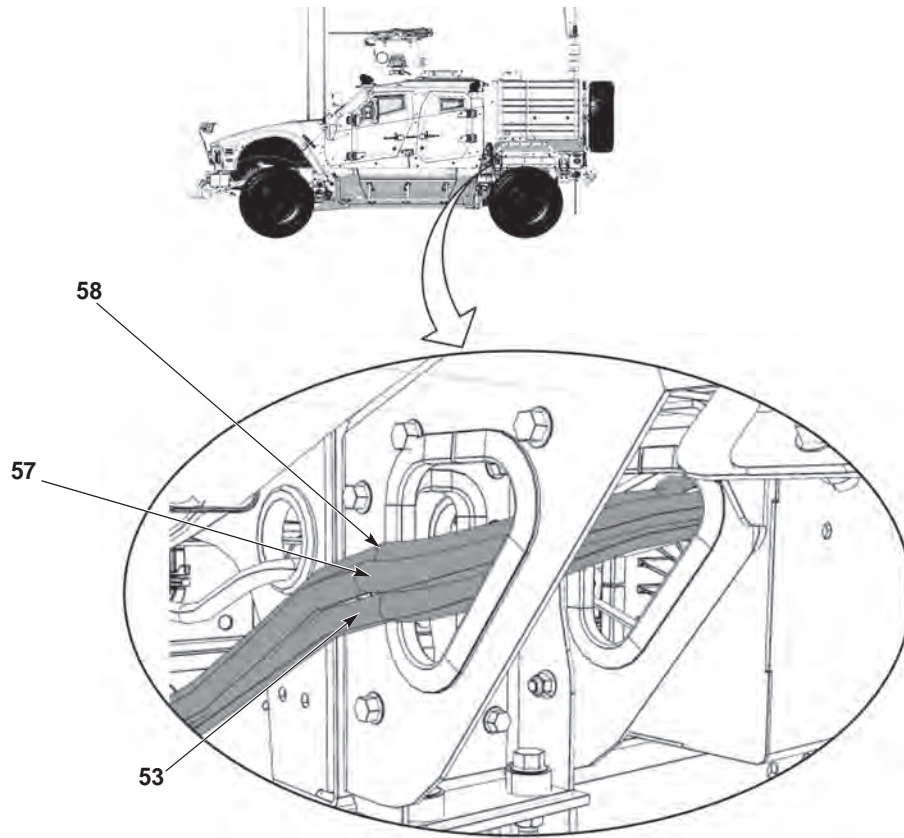
**REMOVAL – CONTINUED****NOTE**

Tag and mark all cables and connectors, note all routing prior to removal to ensure proper installation.

34. Route cables (53, 57, and 58) from the underside of the cargo deck.

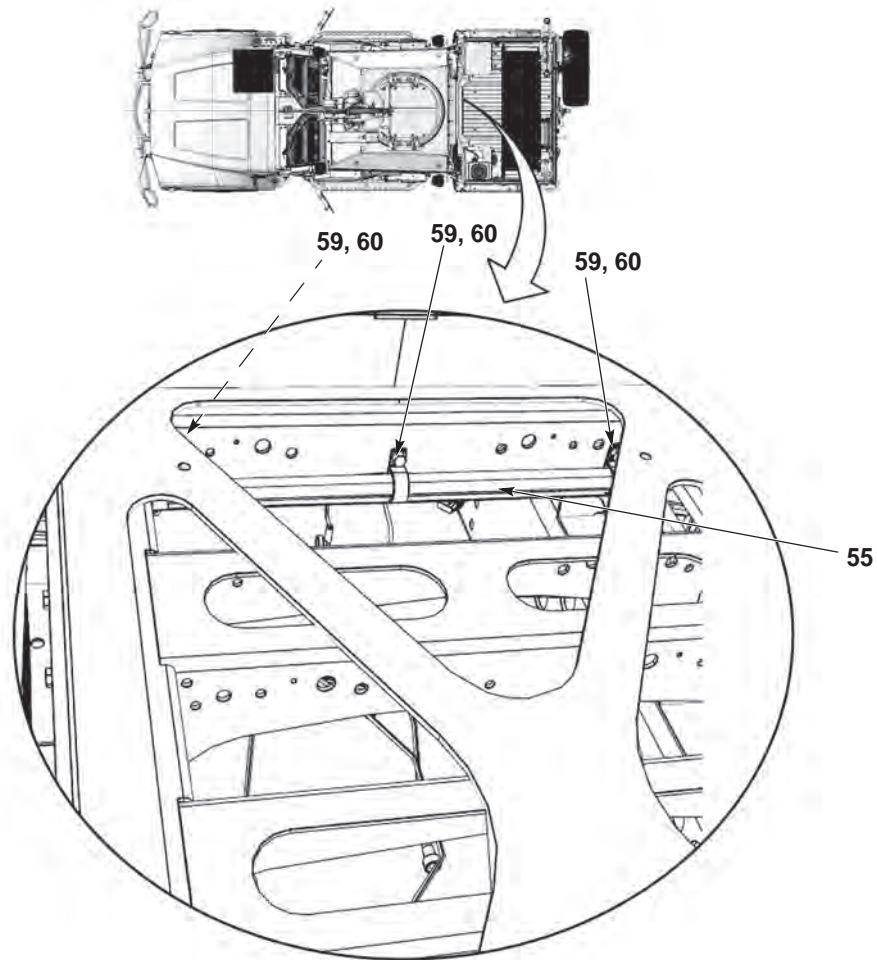
**REMOVAL – CONTINUED****NOTE**

Tag and mark all cables and connectors, note all routing prior to removal to ensure proper installation.

35. Remove three screws (59) from cable clamps (60), located under the quicklock floor.
36. Route cable (55) from driver side of the cargo deck to the passenger side of the cargo deck and from the underside of the cargo deck.

## REMOVAL – CONTINUED

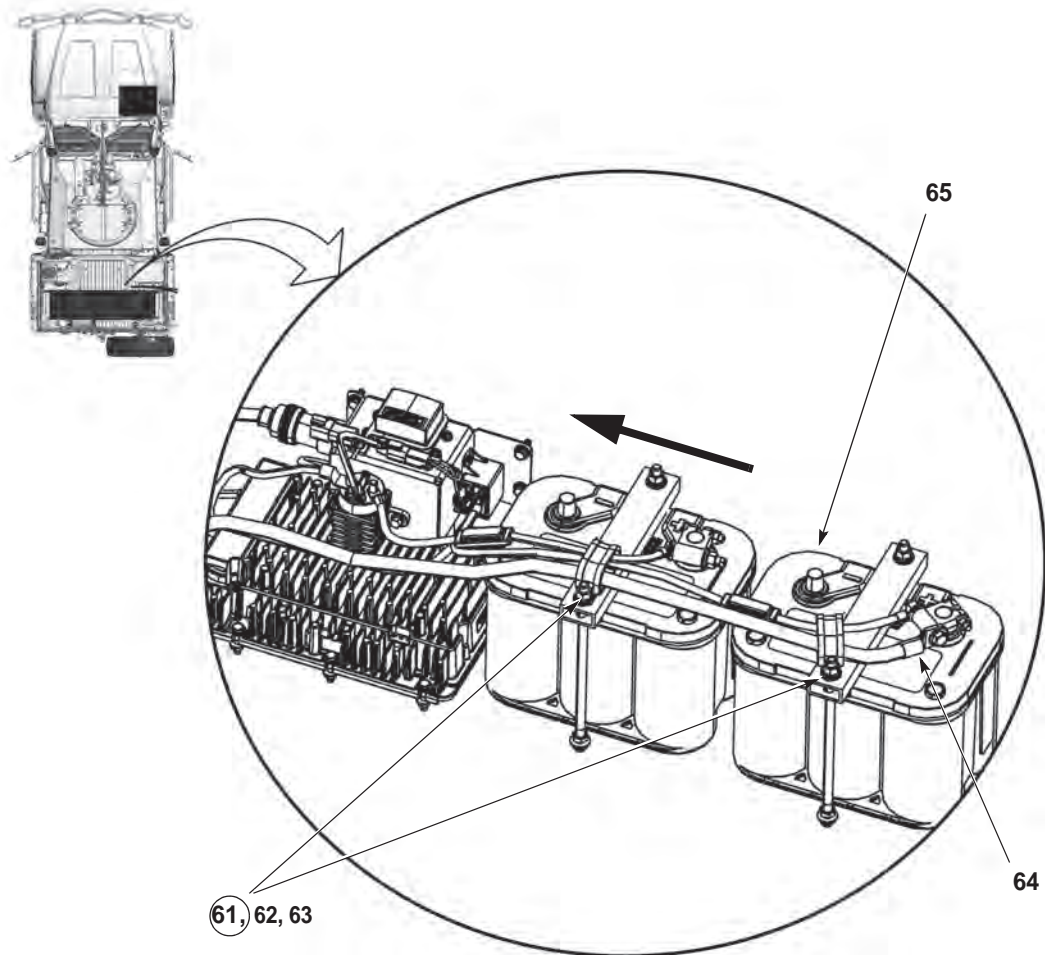
**NOTE**

- As a precondition, the batteries are disconnected by disconnecting the negative battery cable **ONLY**. The following procedure is for disconnecting the remainder battery cables.
- Tag and mark all cables and connectors, note all routing prior to removal to ensure proper installation.

37. Remove two locknuts (61), two washers (62), and two cable clamps (63). Discard locknuts (61).

38. Disconnect 3905122 cable (64) from rear battery (65) on the passenger side.

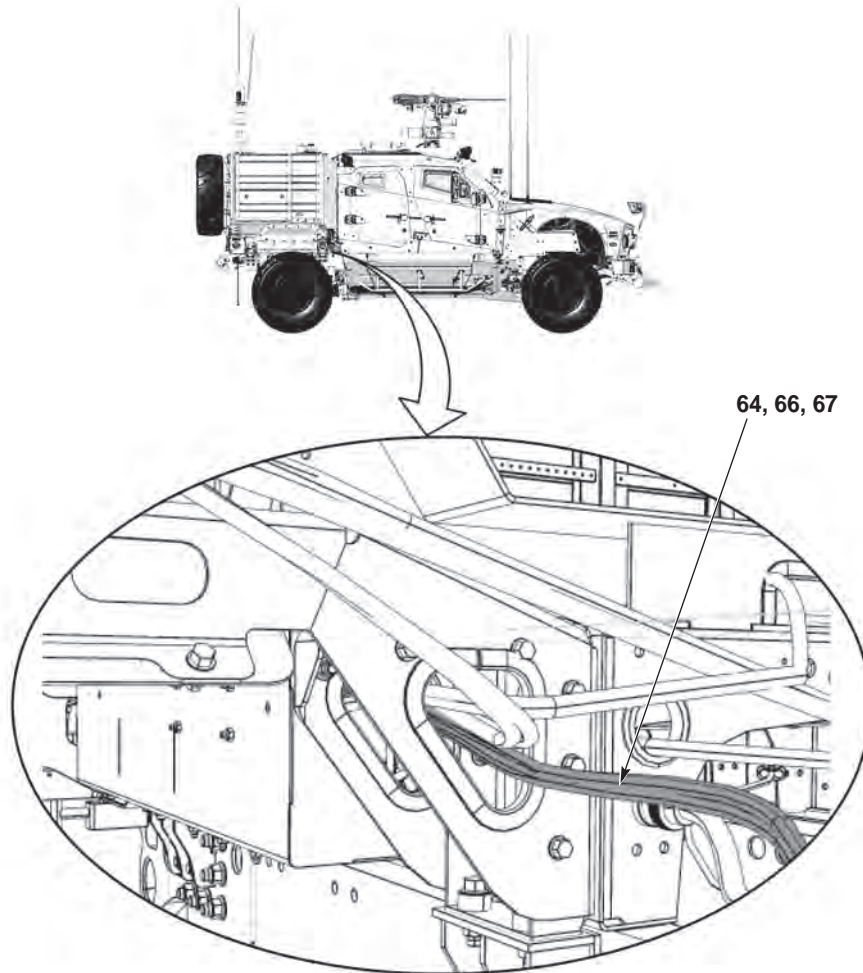

**REMOVAL – CONTINUED****NOTE**

Tag and mark all cables and connectors, note all routing prior to removal to ensure proper installation.

39. Route cables (64, 66, and 67) from the underside of the cargo deck.

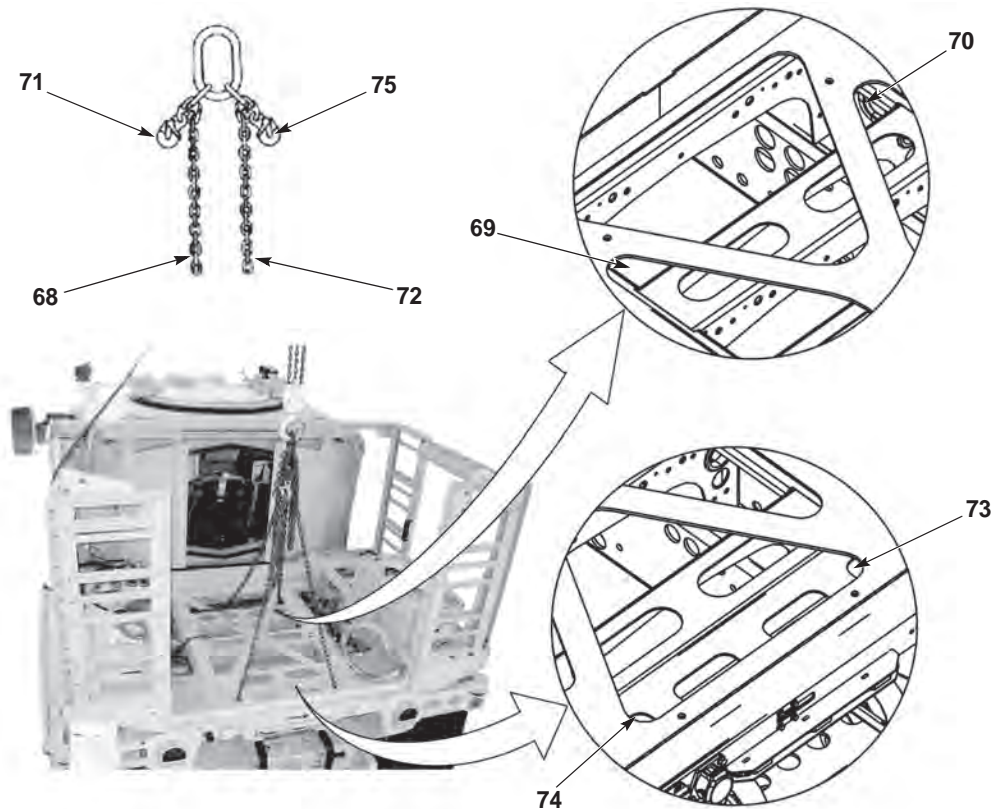

## REMOVAL – CONTINUED

**WARNING**

**Cargo deck weighs 1950 lbs (885 kg). Do not lift or move cargo body without the aid of an assistant and a lifting device. Failure to comply may result in injury or death to personnel.**

40. Attach one end of the sling assembly (68) through cargo deck frame hole (69) and back out through cargo deck frame hole (70), and secure to hook (71).
41. Thread the second end of the sling assembly (72) through the rear passenger side gap (73) in cargo deck frame, and pull across to driver side of cargo deck.
42. Continue to thread the second end of the sling assembly (72) through the rear driver side gap (74) in cargo deck frame and secure to hook (75).

**NOTE**

Leave rear chains slightly longer than front chains to compensate for uneven weight distribution.

43. Adjust the sling assembly to lift cargo deck uniformly.

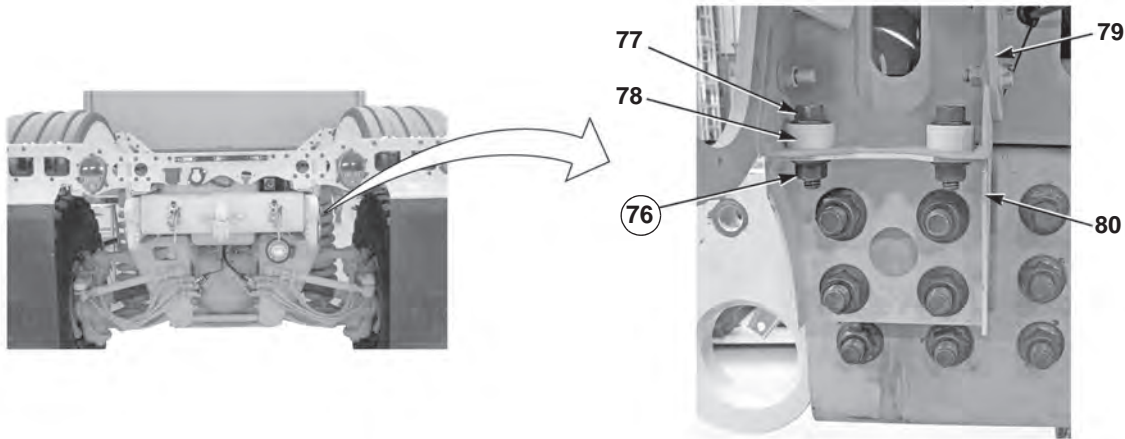
**REMOVAL – CONTINUED****NOTE**

- All four cargo deck supports are removed the same way.
  - Rear passenger side cargo deck support bracket shown.
44. Remove two locknuts (76), screws (77), and bushings (78) from cargo deck support bracket (79) and frame support bracket (80). Discard locknuts (76).
  45. Repeat procedure for remaining cargo deck supports.

**WARNING**

**Cargo deck weighs 1950 lbs (885 kg). Do not lift or move cargo body without the aid of an assistant and a lifting device. Failure to comply may result in injury or death to personnel.**

**NOTE**

Raise cargo deck only 6 inches.

46. With the aid of an assistant and lifting device, slowly raise cargo deck to ensure it does not catch or bind.

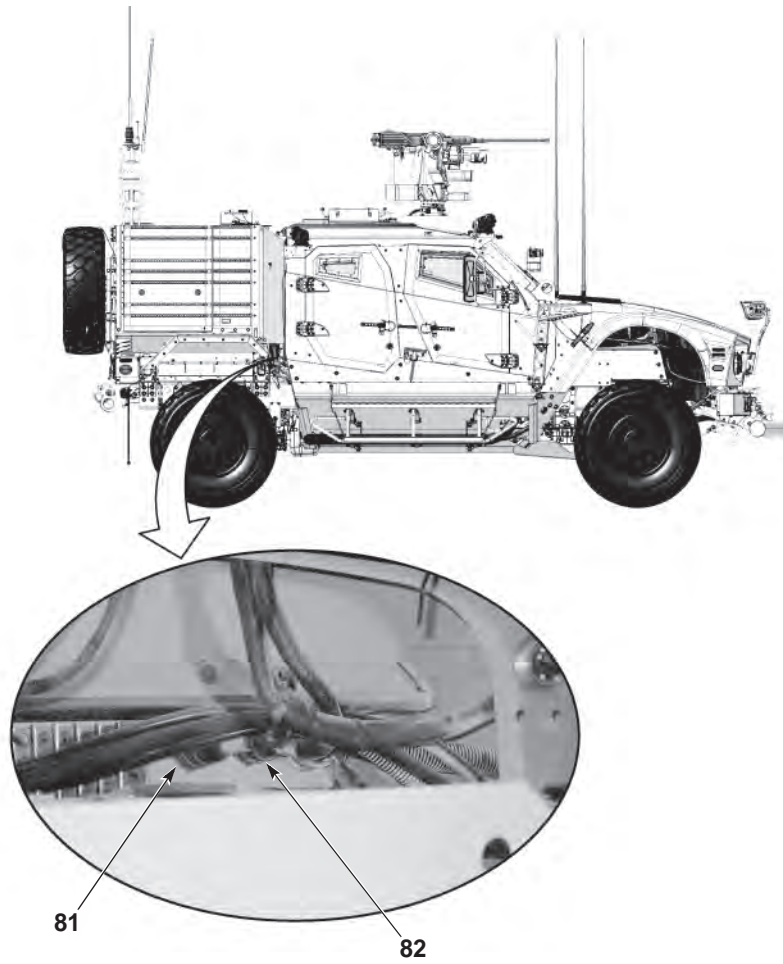
**REMOVAL – CONTINUED**

47. Disconnect bulkhead connectors (81 and 82) from capsule.

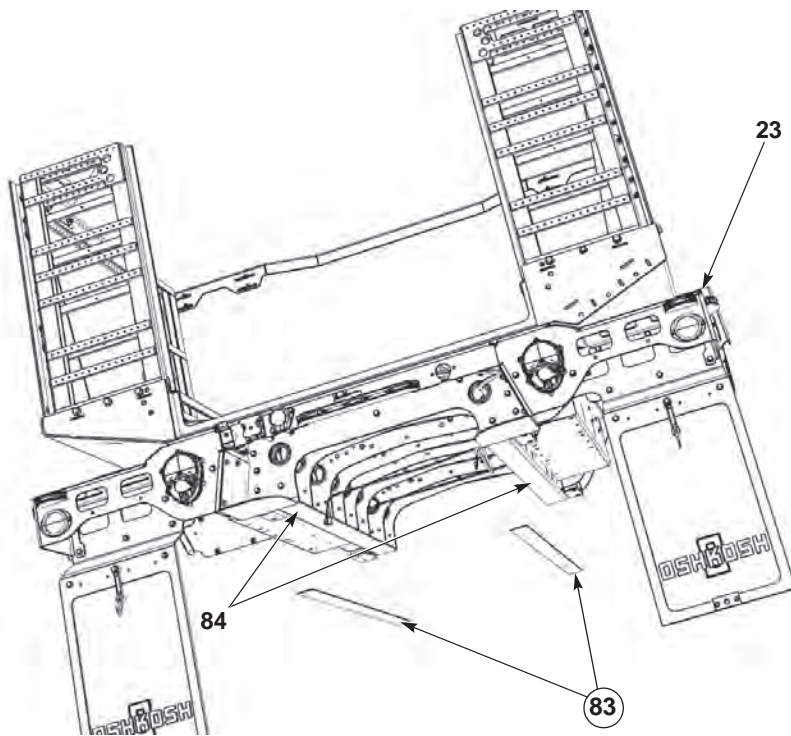
**REMOVAL – CONTINUED****WARNING**

**Cargo deck weighs 1950 lbs (885 kg). Do not lift or move cargo body without the aid of an assistant and a lifting device. Failure to comply may result in injury or death to personnel.**

48. With the aid of an assistant and lifting device, remove cargo deck (23) from vehicle.
49. Remove two rubber strips (83) from frame rails (84) of cargo deck (23). Discard rubber strips (83).

**END OF TASK**

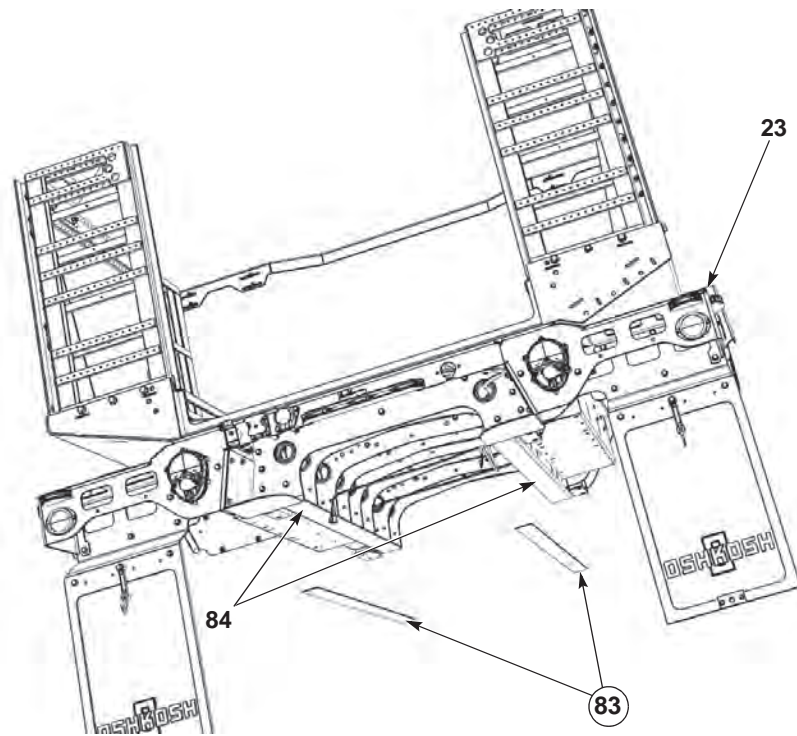
**INSTALLATION****WARNING**

**Cargo deck weighs 1950 lbs (885 kg). Do not lift or move cargo body without the aid of an assistant and a lifting device. Failure to comply may result in injury or death to personnel.**

1. Install two new rubber strips (83) to the frame rails (84) of cargo deck (23).

## INSTALLATION – CONTINUED

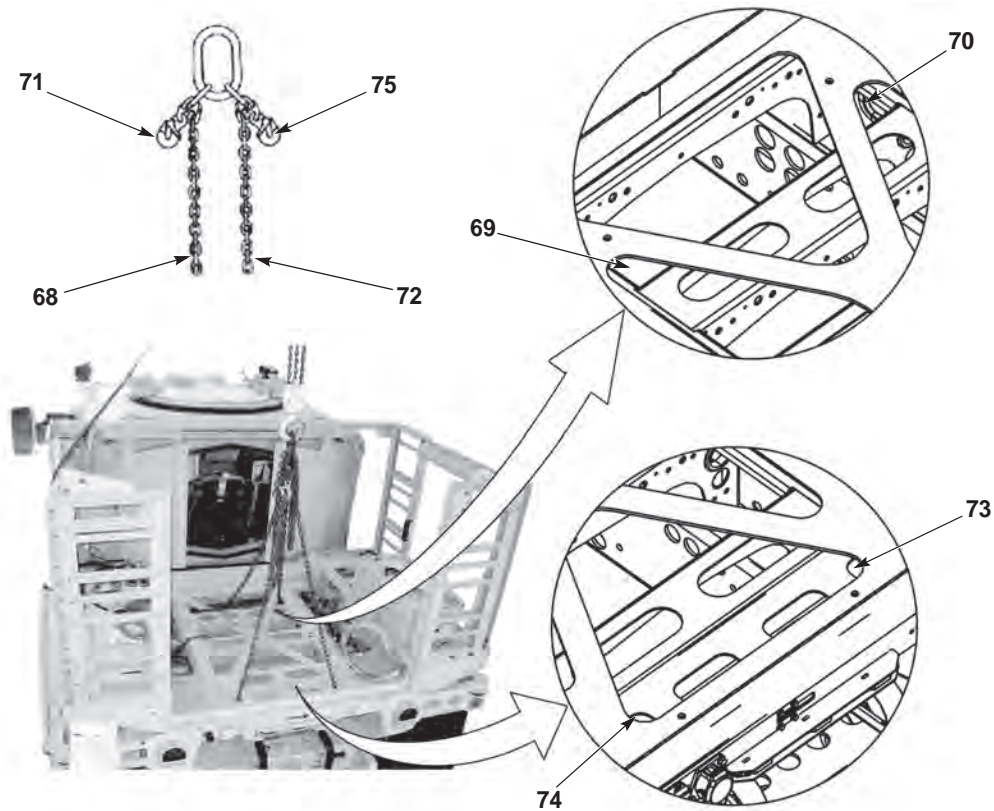

2. Attach one end of the sling assembly (68) through cargo deck frame hole (69) and back out through cargo deck frame hole (70), and secure to hook (71).
3. Thread the second end of the sling assembly (72) through the rear passenger side gap (73) in cargo deck frame, and pull across to driver side of cargo deck.
4. Continue to thread the second end of the sling assembly (72) through the rear driver side gap (74) in cargo deck frame and secure to hook (75).

**NOTE**

Leave rear chains slightly longer than front chains to compensate for uneven weight distribution.

5. Adjust the sling assembly to lift cargo deck uniformly.

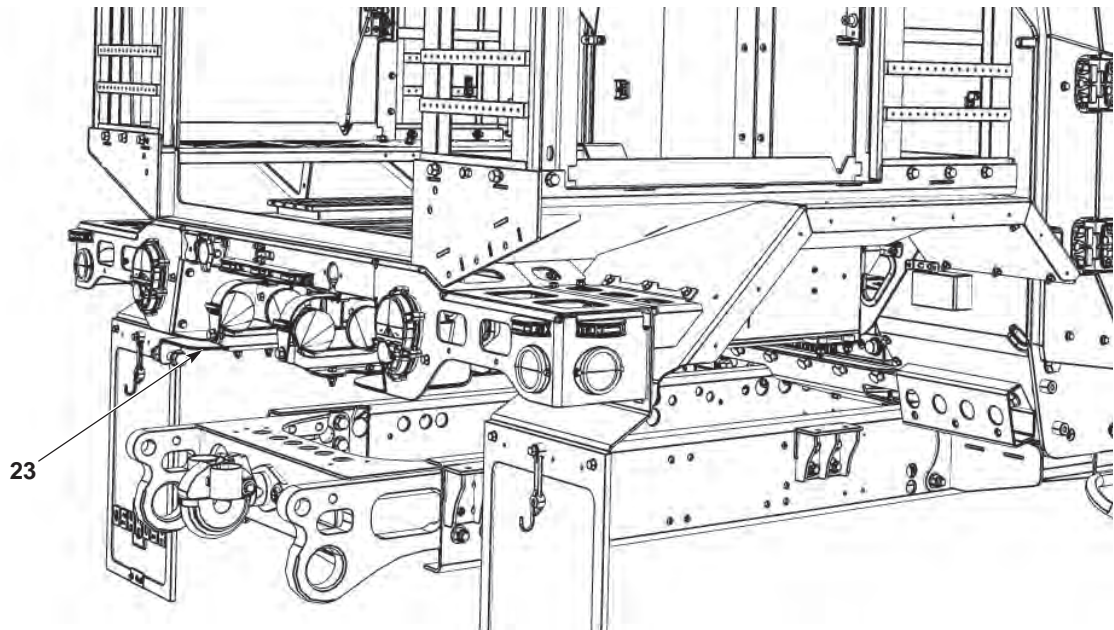

**INSTALLATION – CONTINUED****WARNING**

Cargo deck weighs 1950 lbs (885 kg). Do not lift or move cargo body without the aid of an assistant and a lifting device. Failure to comply may result in injury or death to personnel.

**WARNING**

Keep hands and fingers away from pinch point areas of the cargo deck assembly. Hands and fingers could get crushed. Failure to comply may result in injury to personnel.

6. With the aid of an assistant and lifting device, lift cargo deck (23) until cargo deck is 6 in. above vehicle frame.

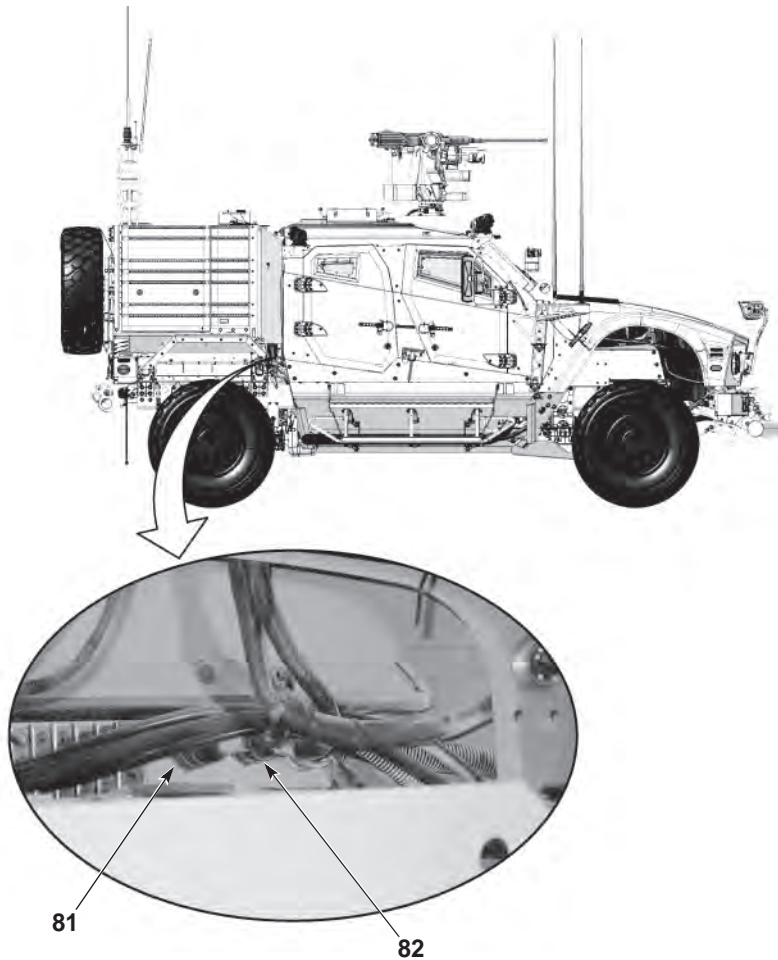
**INSTALLATION – CONTINUED**

7. Connect bulkhead connectors (81 and 82) to capsule.

**WARNING**

**Cargo deck weighs 1950 lbs (885 kg). Do not lift or move cargo body without the aid of an assistant and a lifting device. Failure to comply may result in injury or death to personnel.**

**WARNING**

**Keep hands and fingers away from pinch point areas of the cargo deck assembly. Hands and fingers could get crushed. Failure to comply may result in injury to personnel.**

**NOTE**

To aid in alignment of the cargo deck, use guide pins or punches in the frame support bracket.

8. With the aid of an assistant and lifting device, position cargo deck (83) on vehicle.

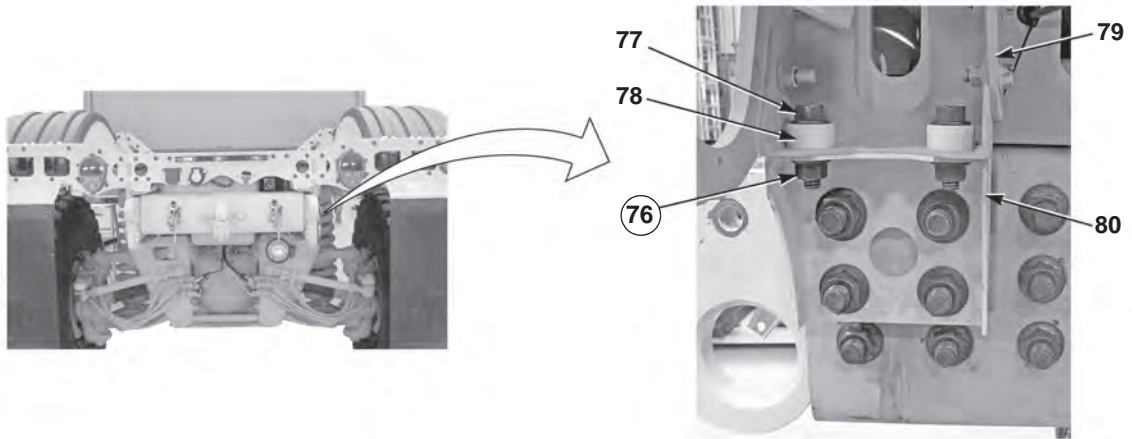
**INSTALLATION – CONTINUED****NOTE**

- All four cargo deck supports are installed the same way.
  - Rear passenger side cargo deck support bracket shown.
9. Secure cargo deck support bracket (79) to frame support bracket (80) with two screws (77), two bushings (78), two new locknuts (76). Torque locknuts (76) to 80 ft - lbs (108 N•m).
  10. Repeat procedure for remaining cargo deck supports.
  11. Remove sling assembly.

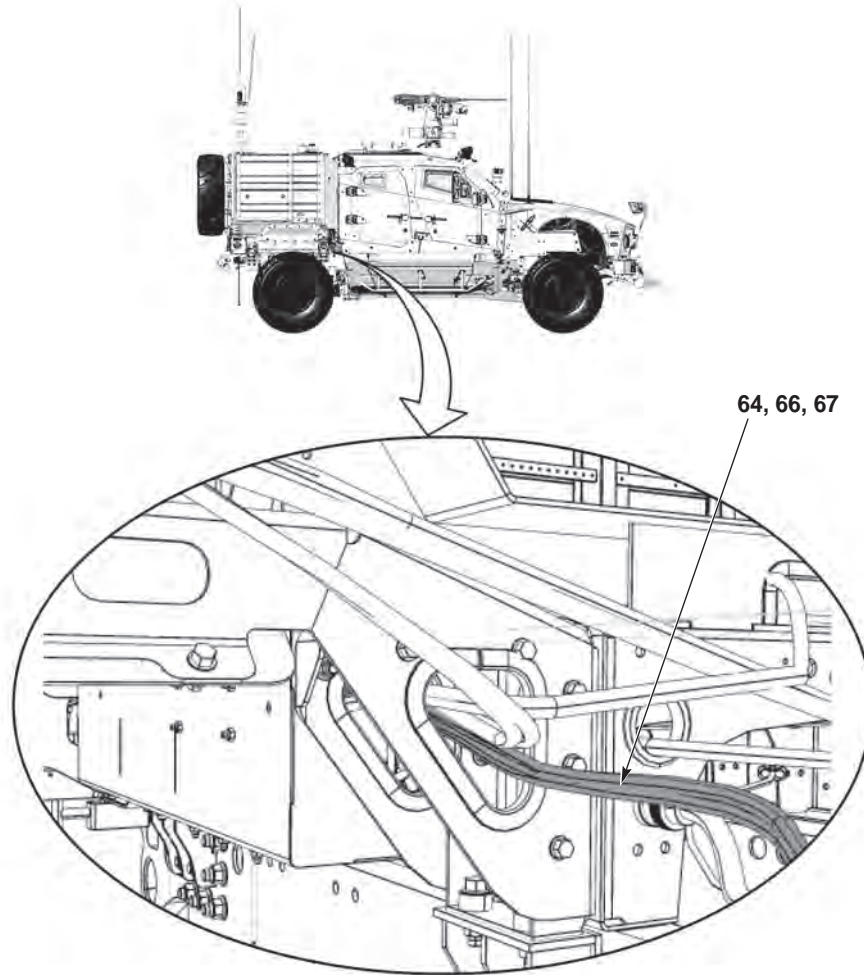
**INSTALLATION – CONTINUED****NOTE**

- Note, all tagged and marked cables and connectors prior to the removal procedure for proper installation.
- Install cable ties as needed.

12. Route cables (64, 66, and 67) through the underside of the cargo deck.

## INSTALLATION – CONTINUED

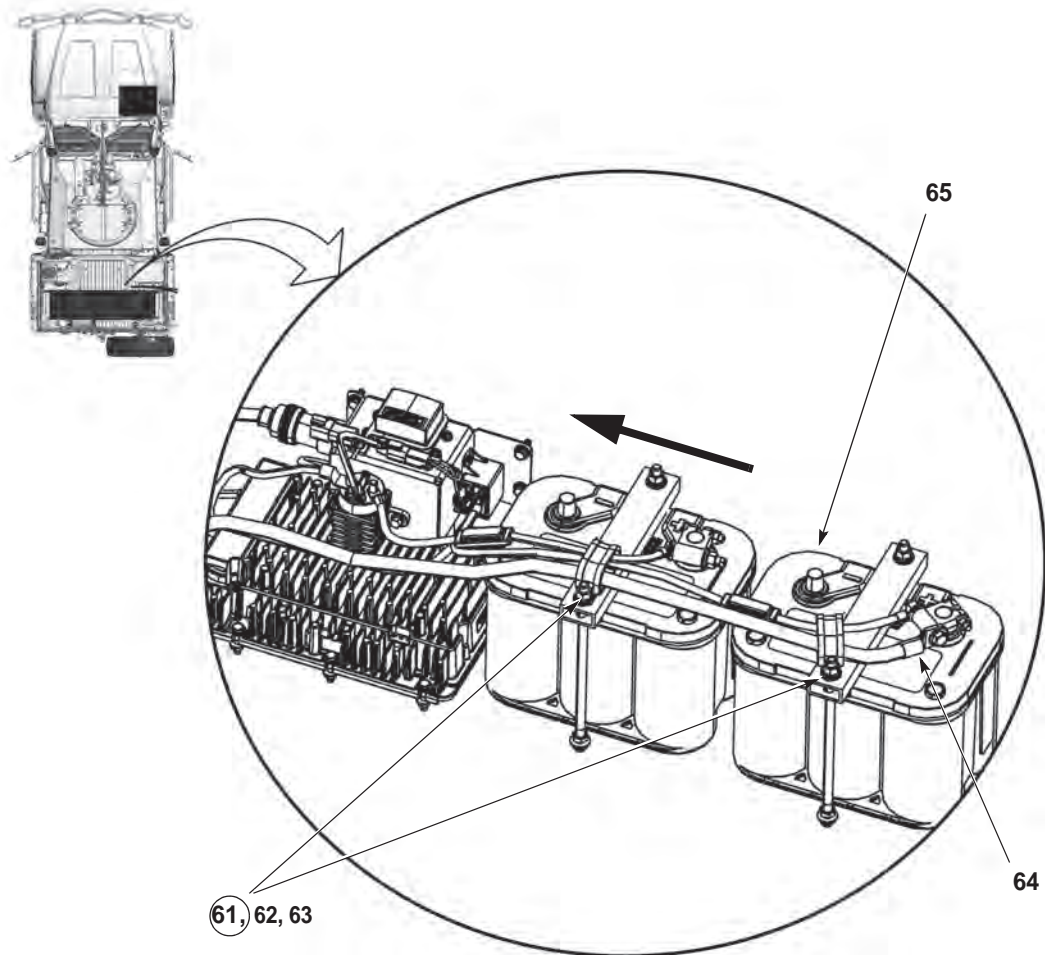
**NOTE**

- As a precondition, the batteries are disconnected by disconnecting the negative battery cable **ONLY**. The following procedure is for connecting the remainder cables.
- Note, all tagged and marked cables and connectors prior to the removal procedure for proper installation.

13. Connect 3905122 cable (64) to the positive terminal of rear battery (65) on the passenger side.
14. Install two cable clamps (63) using two washers (62) and two new locknuts (61).

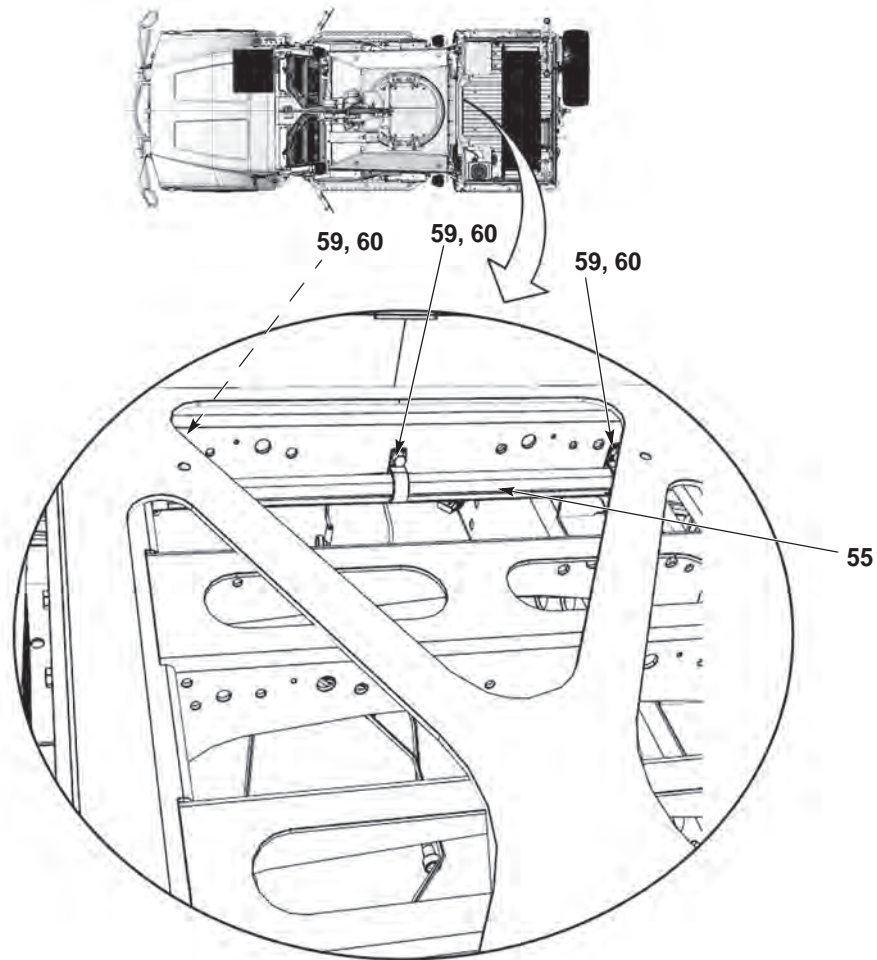

**INSTALLATION – CONTINUED****NOTE**

- Note, all tagged and marked cables and connectors prior to the removal procedure for proper installation.
- Install cable ties as needed.

15. Route cable 1139 (55) from the passenger side of cargo deck to the driver side of cargo deck.
16. Install three screws (59) securing all cable clamps (60), located under the quicklock floor.

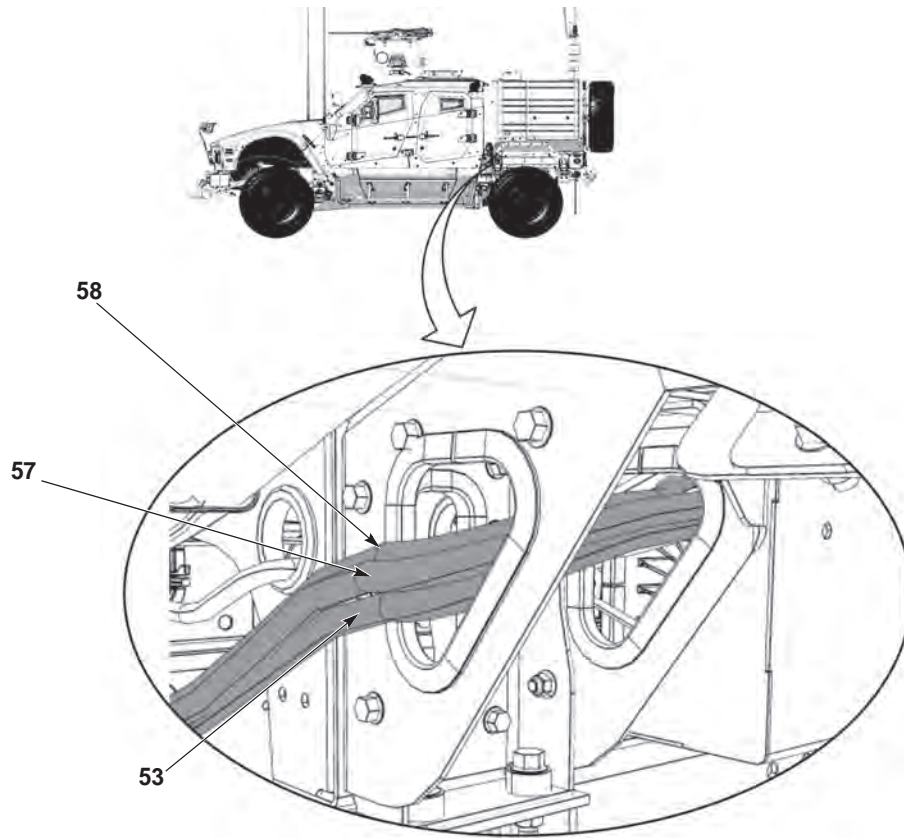

**INSTALLATION – CONTINUED****NOTE**

- Note, all tagged and marked cables and connectors prior to the removal procedure for proper installation.
- Install cable ties as needed.

17. Route cables (53, 57, and 58) through the underside of cargo deck.

## INSTALLATION – CONTINUED

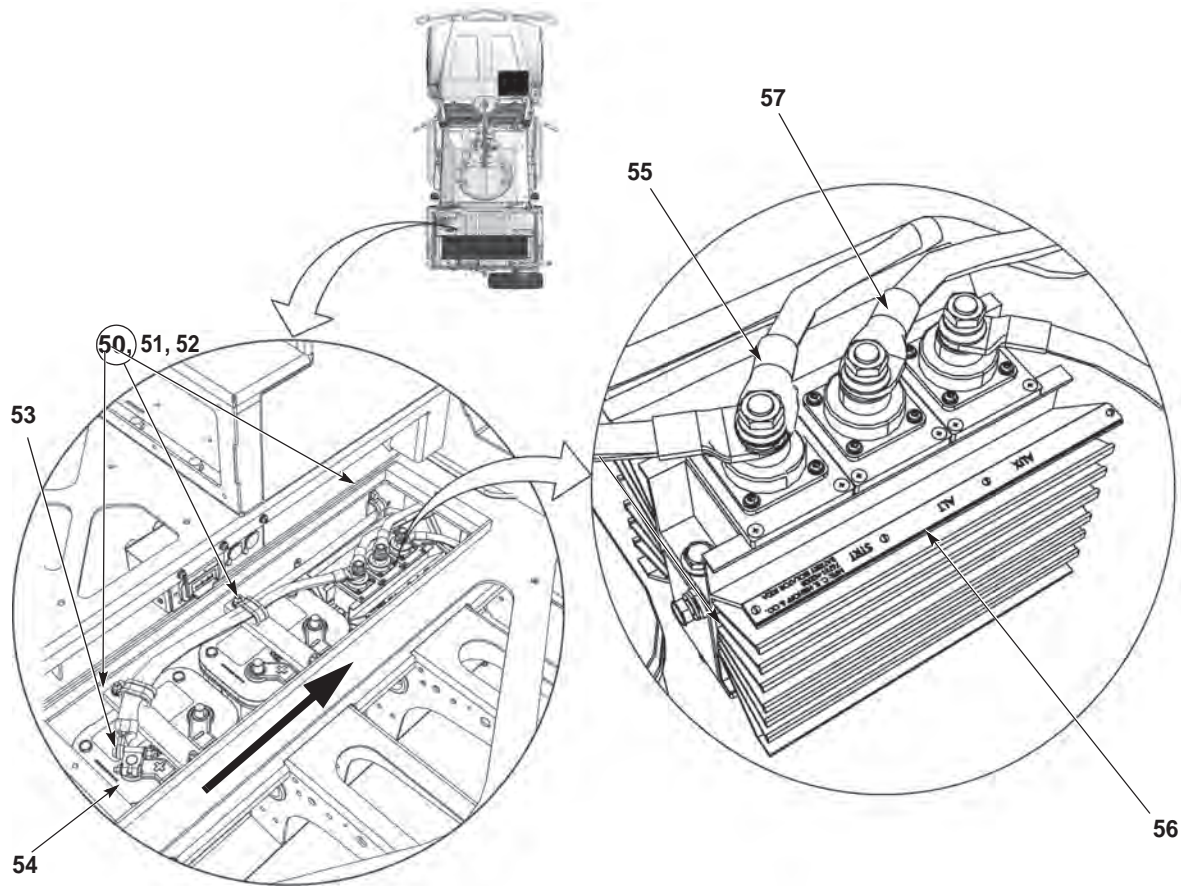
**NOTE**

- As a precondition, the batteries are disconnected by disconnecting the negative battery cable **ONLY**. The following procedure is for connecting the remainder cables.
- Note, all tagged and marked cables and connectors prior to the removal procedure for proper installation.
- Install cable ties as needed.

18. Connect cable (57) from ALT terminal on battery isolator (56).
19. Connect cable (55) from STRT terminal on battery isolator (56).
20. Connect 3904931 battery cable (53) from the drivers side rear battery (54).
21. On the drivers side of the cargo deck, install cable clamps (52) using three washers (51) and three new locknuts (50).

---

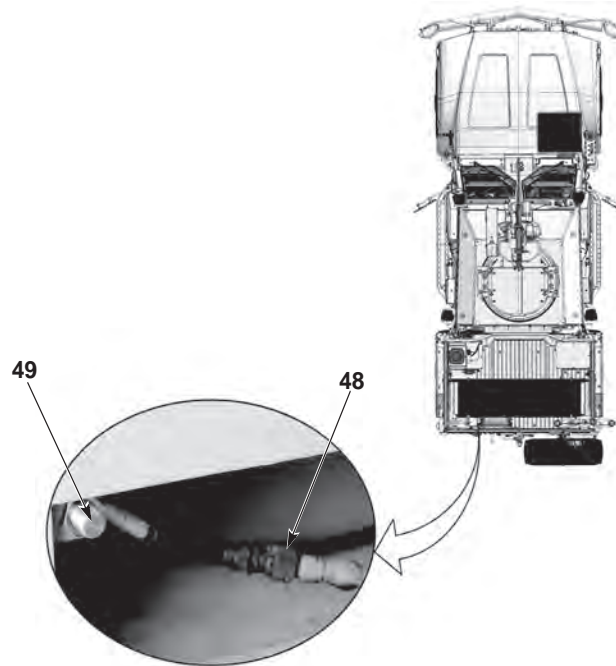
**INSTALLATION – CONTINUED****NOTE**

- Install wire harness as noted prior to removal.
- Install cable ties as needed.

22. Connect wire harness (48) to the proximity switch (49).

## INSTALLATION – CONTINUED

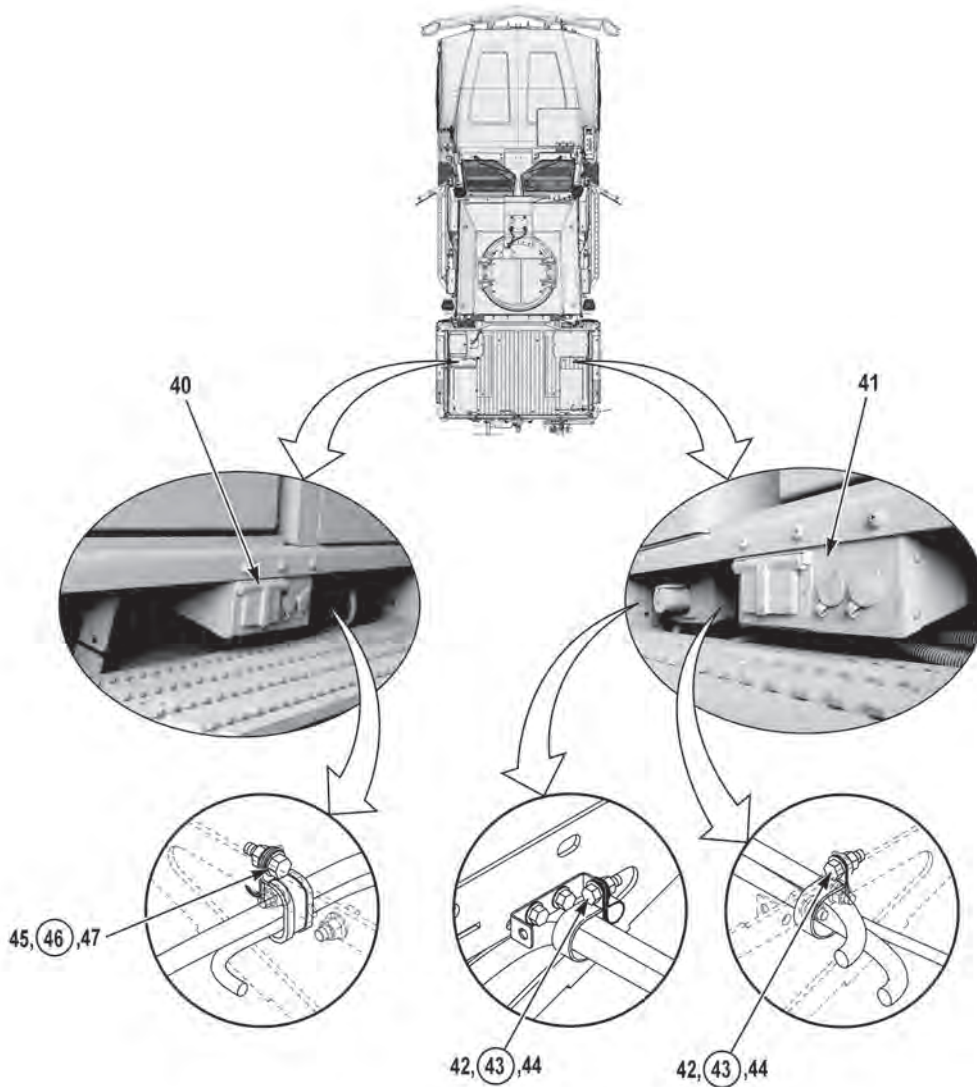
**NOTE**

- Install wire harness as noted prior to removal.
- Install cable ties as needed.

23. Install cushion clip (47) on wire harness using screw (45) and new locknut (46).
24. Connect the wire harnesses to the passenger side power outlets (41).
25. Install two cushion clips (44) on wire harness using two screws (42) and two new locknuts (43).
26. Connect the wire harness to the driver side power outlets (40).

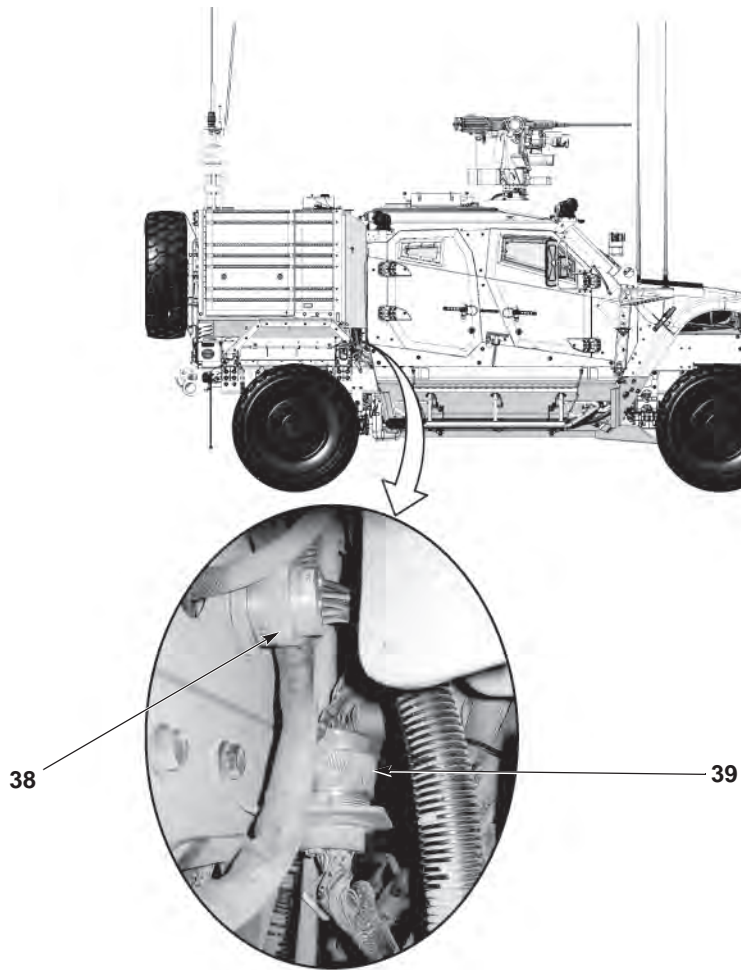
**INSTALLATION – CONTINUED****NOTE**

- Install hose connectors as noted in removal
- Install cable ties as required.

27. Connect cannon plug (38) and cannon plug (39).

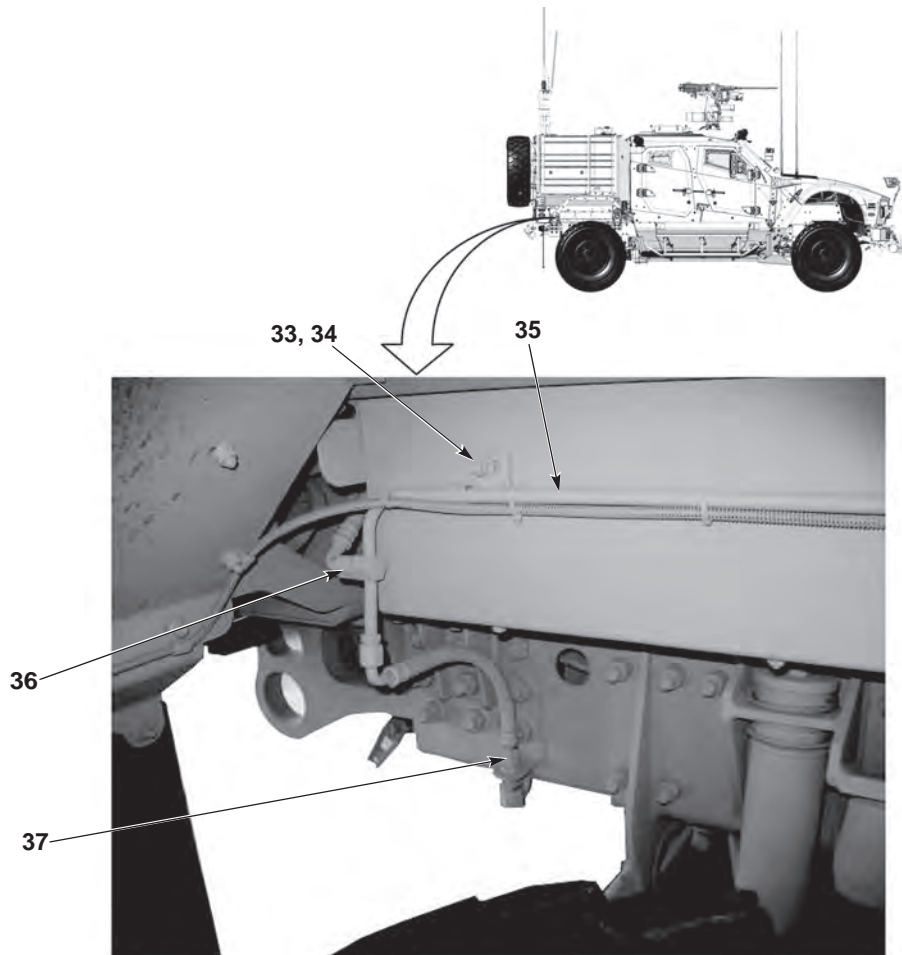
**INSTALLATION – CONTINUED****NOTE**

Install cable ties as needed.

28. Install the fire suppression disbursement rail (35), to the cargo deck and secure with washer (34) and nut (33).
29. Connect the fire suppression disbursement hose (37) to the fire suppression disbursement rail (35).
30. Connect the fire suppression disbursement hose (36), to the fire suppression disbursement rail (35).

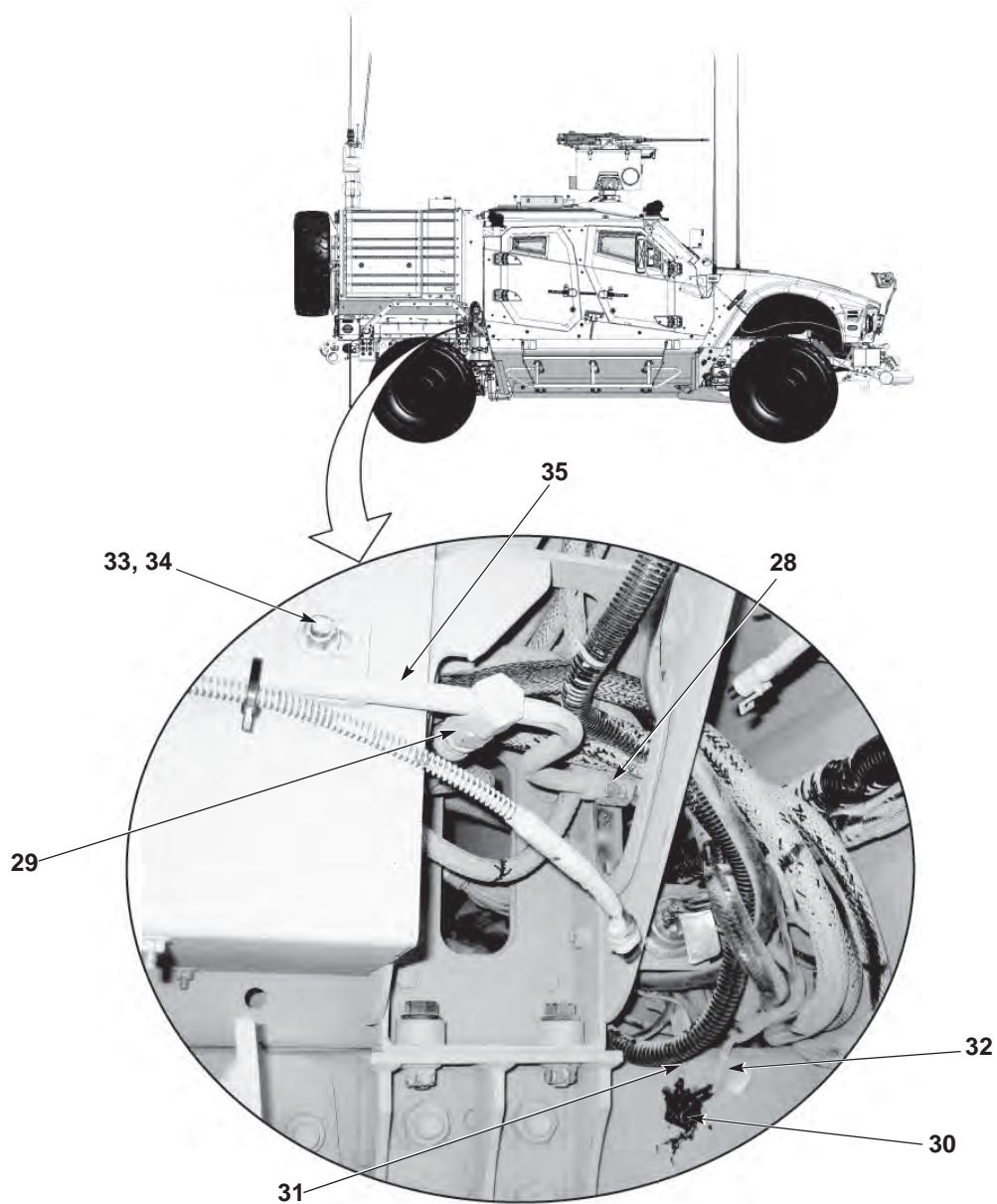

## INSTALLATION – CONTINUED

**NOTE**

- Install all hose connectors as noted during removal.
- Install cable ties as required.

31. Install nut (33) and washer (34) to front section of the fire suppression disbursement rail (35).
32. Install grounding wires (31 and 32) using screw (30).
33. Connect the fire suppression disbursement hose (29).
34. Connect the fire suppression disbursement hose (28).

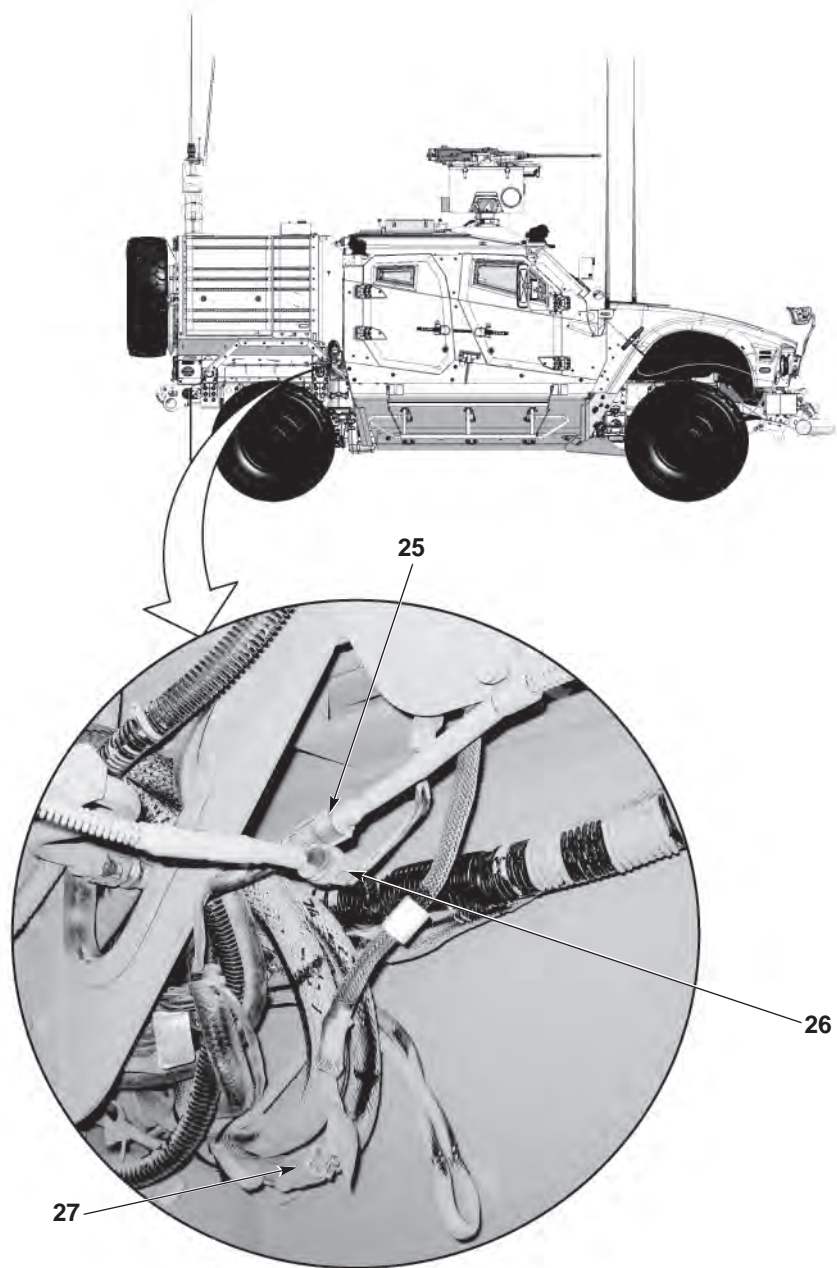
**INSTALLATION – CONTINUED****NOTE**

- Route wires as noted during removal.
- Install cable ties as required.

35. Connect wire connector LOC1 (27).

36. Connect wire connector LOC1 (25) and wire connector LOC3 (26).

**INSTALLATION – CONTINUED****WARNING**

**Fuel is flammable and can explode. Keep fuel away from open flame and keep fire extinguisher within easy reach when working with fuel. Do not work on fuel system when engine is hot. Fuel can be ignited by hot engine. Smoking is prohibited while working with fuel. Failure to comply may result in injury or death to personnel.**

37. Attach the fuel filler tube assembly bracket (24) to the cargo deck (23), securing it with screws (22) and two new locknuts (21).

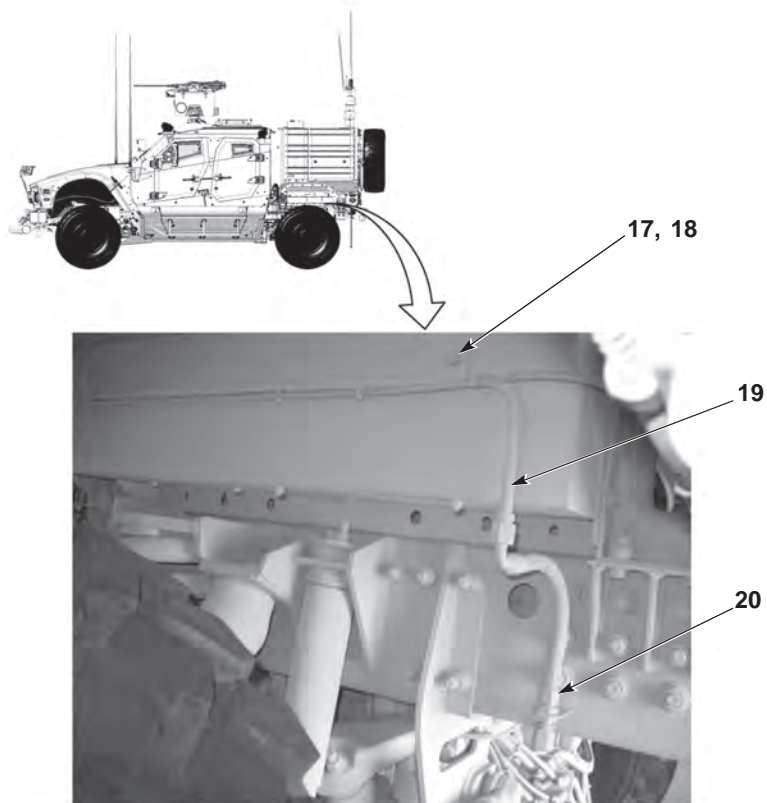
**INSTALLATION – CONTINUED****NOTE**

Install cable ties as needed.

38. Install the fire suppression disbursement rail (19), to the cargo deck and secure with washer (18) and nut (17).
39. Connect the fire suppression disbursement hose (20) to the fire suppression disbursement rail (19).

## INSTALLATION – CONTINUED

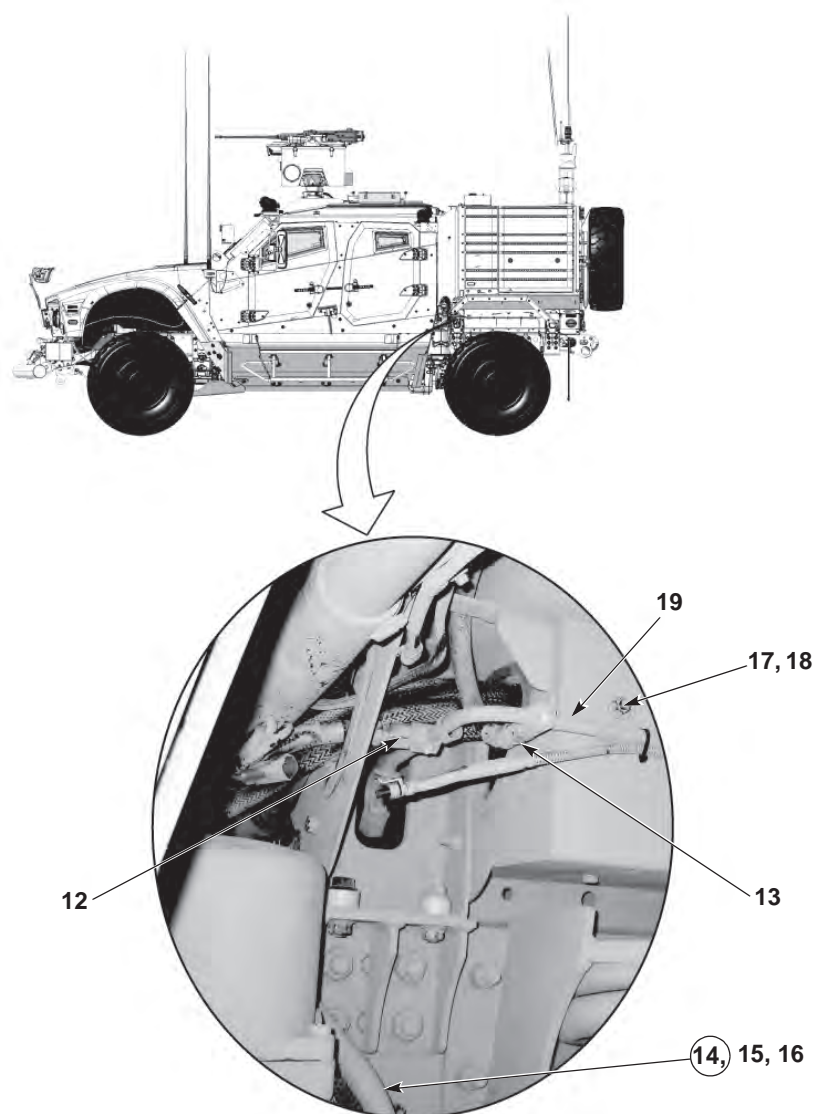
**NOTE**

- Note, all tagged and marked cables and connectors prior to the removal procedure for proper installation.
- Install cable ties as required.

40. Install nut (17) and washer (18) to front section of fire disbursement rail (19).
41. Install grounding strap (16) using washer (15) and new locknut (14).
42. Connect the fire suppression disbursement hose (13).
43. Connect the fire suppression disbursement hose (12).

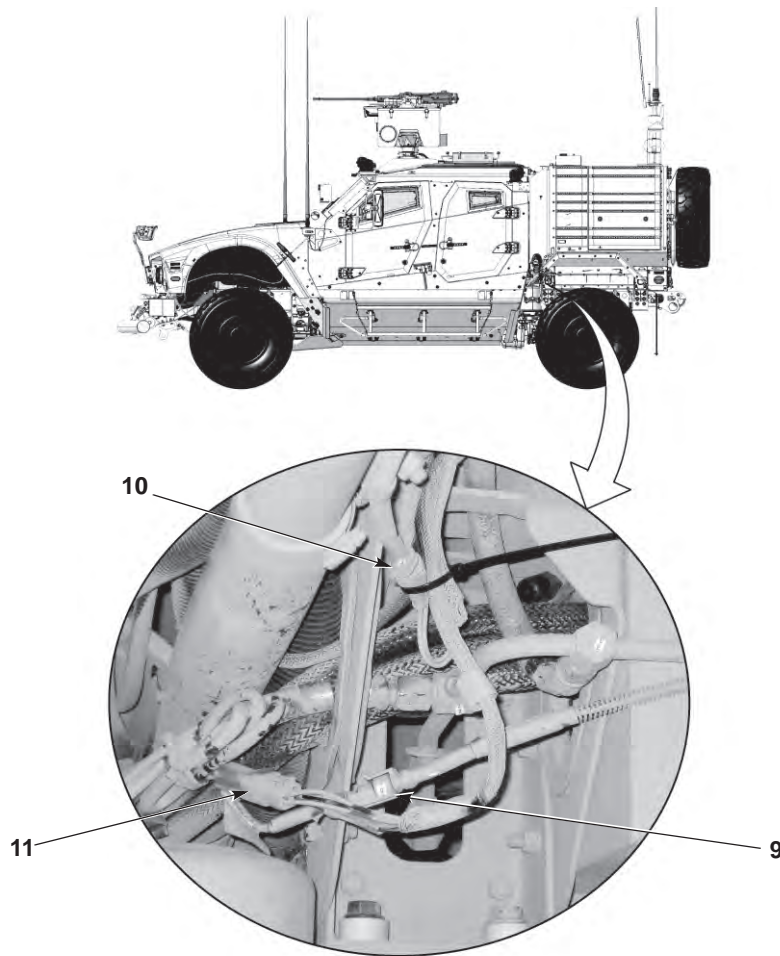
**INSTALLATION – CONTINUED****NOTE**

- Route wire harness as noted during removal.
- Install cable ties as required.

44. Connect wire connector LOC1 (11).

45. Connect wire connector LOC3 (10) and wire connector LOC1 (9).

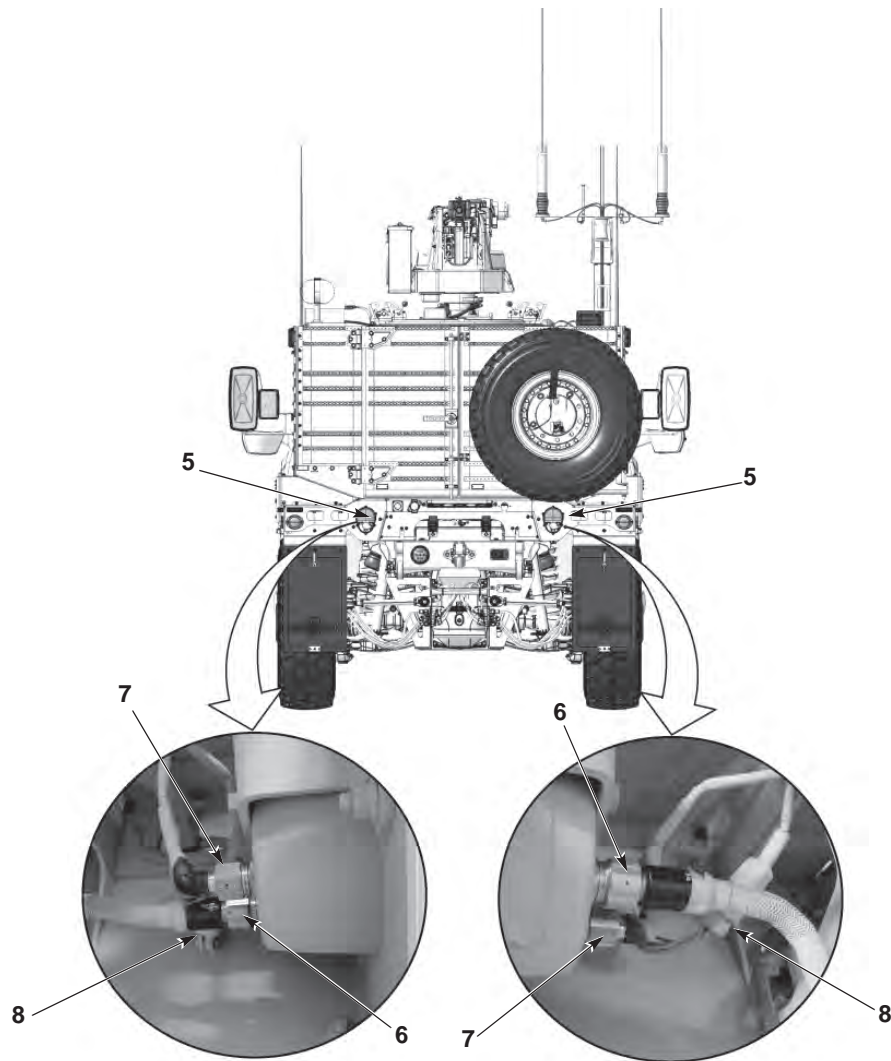

**INSTALLATION – CONTINUED****NOTE**

- Route cables as noted during removal.
- Install cable ties as required.

46. Route cables through cargo deck.

47. Connect connectors (6, 7 and 8) to drivers side and passenger side backup lights (5).

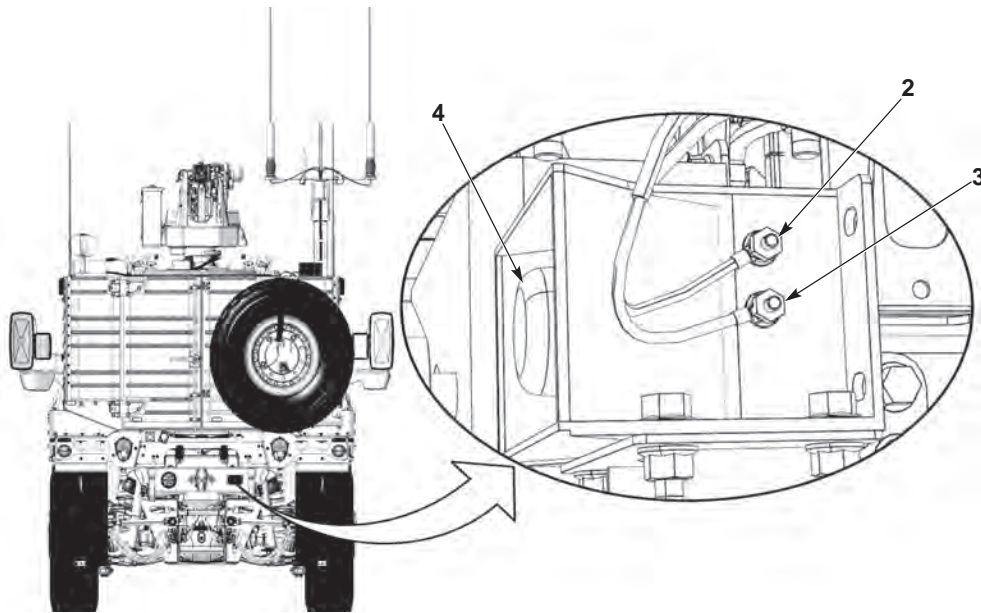
**INSTALLATION – CONTINUED****NOTE**

- Install wire harness as noted prior to removal.
- Install cable ties as needed.

48. Attach connectors (2 and 3), to the backup alarm (4).

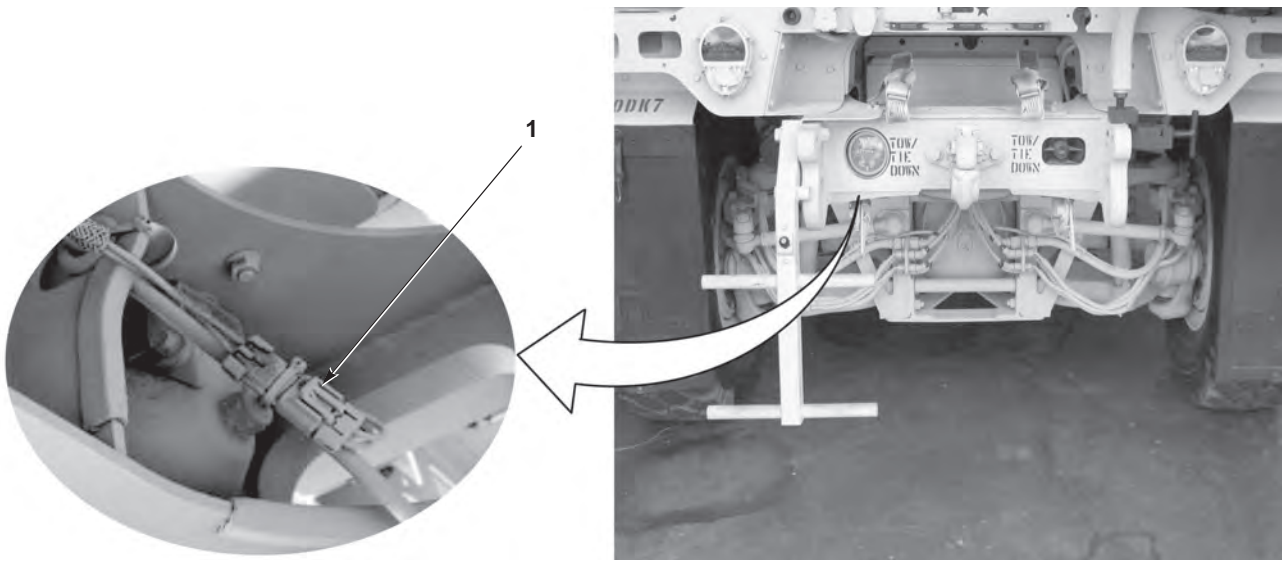
**INSTALLATION – CONTINUED****NOTE**

- Install wire harness as noted prior to removal.
- Install cable ties as needed.

49. Connect connector (1).

50. Perform all Follow-On Maintenance tasks.

**END OF TASK**

**END OF WORK PACKAGE**



---

**CARGO DECK REPLACEMENT (M1240/M1240A1)**

---

**Preconditions**

- Park vehicle
- Engine OFF
- Wheels chocked
- Batteries removed (WP 0191)
- Battery isolator removed (WP 0189)
- Antenna platform assembly removed (WP 0025)
- Crew vehicle receiver/jammer (CVRJ) box removed (WP 0027)
- Driver side and passenger side Check-6 composite lights removed (if equipped) (WP 0193)
- Driver side and passenger side rear composite lights removed (WP 0210)

**Tools and Special Tools**

- Adapter, 3/8" Female, 1/2" Male
- Jackstand (4 required)
- Lifting Device, Minimum Capacity 800 lbs
- Socket, 1-1/8" 3/4" Dr.
- Strap, Nylon, 60 in. (4)
- T-handle from BII (TM 9-2355-335-10)
- Tool Kit, General Mechanic's: Automotive
- Wrench, Torque, 0 to 300 in-lb
- Wrench, Combination, 1-1/8"

**Materials/Parts**

- Locknut (2) (Item 6)
- Locknut (5) (Item 9, 10, 28, 36, 39, and 58)
- Pin, Cotter (4) (Item 19)
- Locknut (3) (Item 24)
- Locknut (2) (Item 46)
- Locknut (8) (Item 51)
- Sealant, RTV Electrical
- Tags, Identification
- Ties, Cable
- Locknut (4) (Item 2)

**Personnel Required**

Two

**Follow-On Maintenance**

- Install driver side and passenger side rear composite lights (WP 0210)
- Install driver and passenger side Check-6 composite lights (if equipped) (WP 0193)
- Install vehicle receiver/jammer (CVRJ) box (WP 0027)
- Install antenna platform (WP 0025)
- Install battery isolator (WP 0189)
- Install batteries (WP 0191)
- Remove and stow wheel chocks

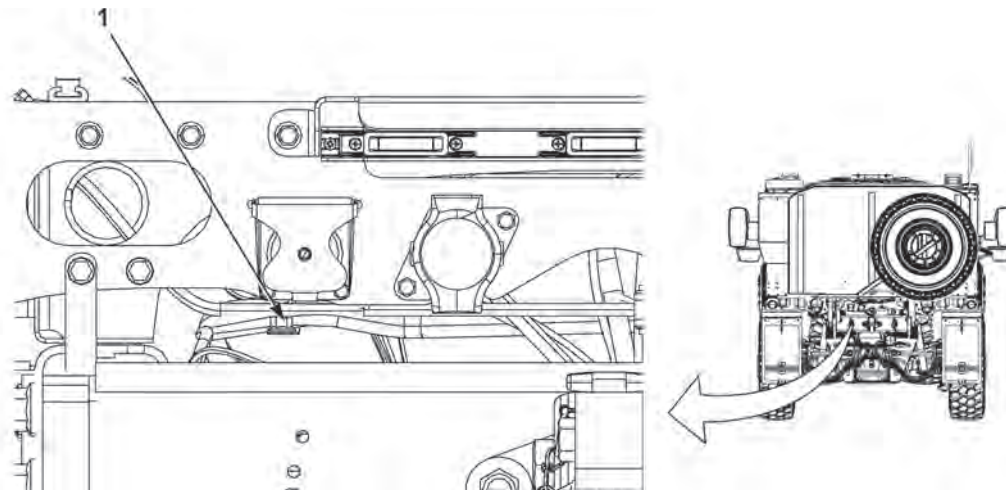
**REMOVAL****NOTE**

Tag and mark connectors prior to removal to ensure proper installation.

1. Disconnect connector (1).

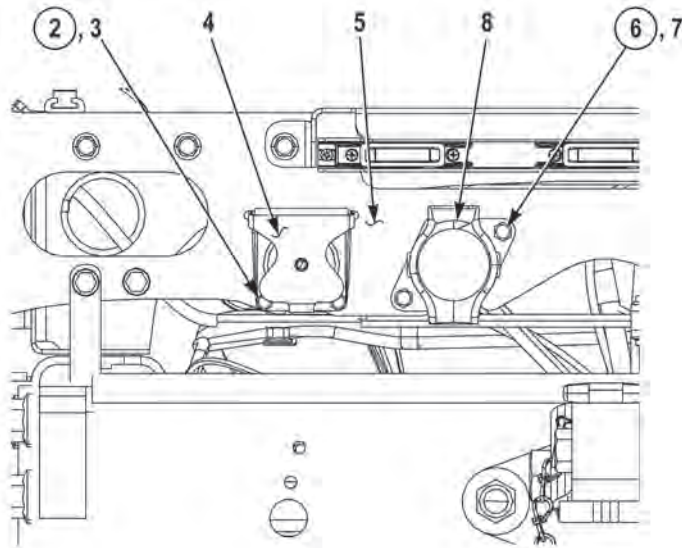

2. Remove four locknuts (2), screws (3), and connector (4) from cargo deck (5). Discard locknuts (2).
3. Remove two locknuts (6), screws (7), and connector (8) from cargo deck (5). Discard locknuts (6).

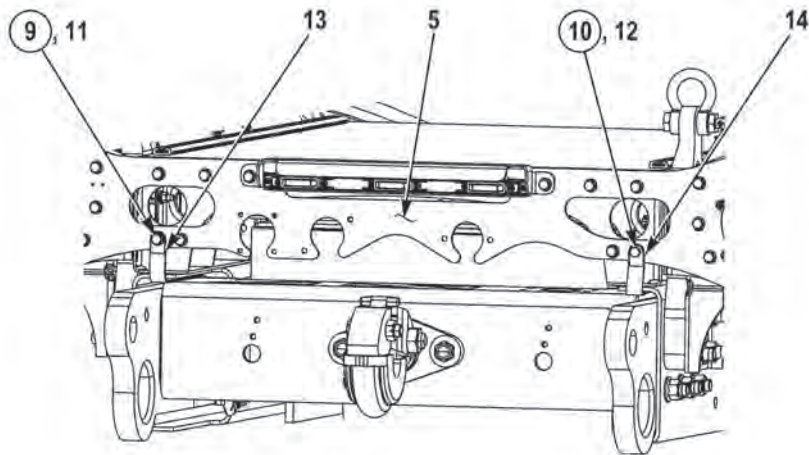

### NOTE

Note placement of ground straps prior to removal to ensure proper installation.

4. Remove two locknuts (9 and 10), screws (11 and 12), and ground straps (13 and 14) from cargo deck (5). Discard locknuts (9 and 10).



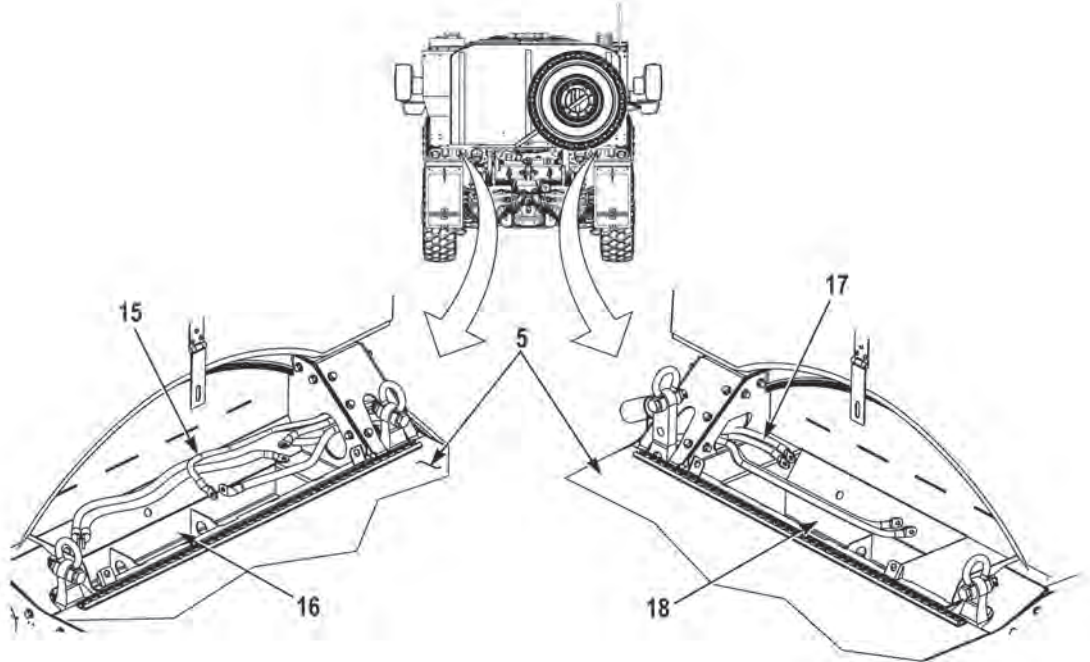

### NOTE

Note routing and position of battery cables prior to removal to ensure proper installation.

5. Remove driver side battery cables (15) from driver side battery box (16) and cargo deck (5).
6. Remove passenger side battery cables (17) from passenger side battery box (18) and cargo deck (5).

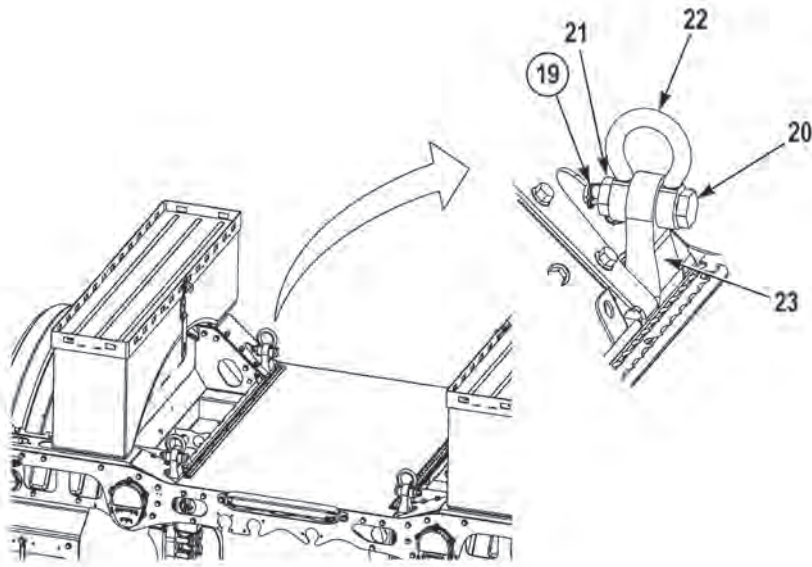

### NOTE

All cargo deck shackles are removed the same way. Driver side front shackle shown.

7. Remove cotter pin (19) from screw (20). Discard cotter pin (19).
8. Remove nut (21), screw (20), and shackle (22) from tie down bracket (23).
9. Repeat Steps (7) and (8) to remove three remaining shackles.

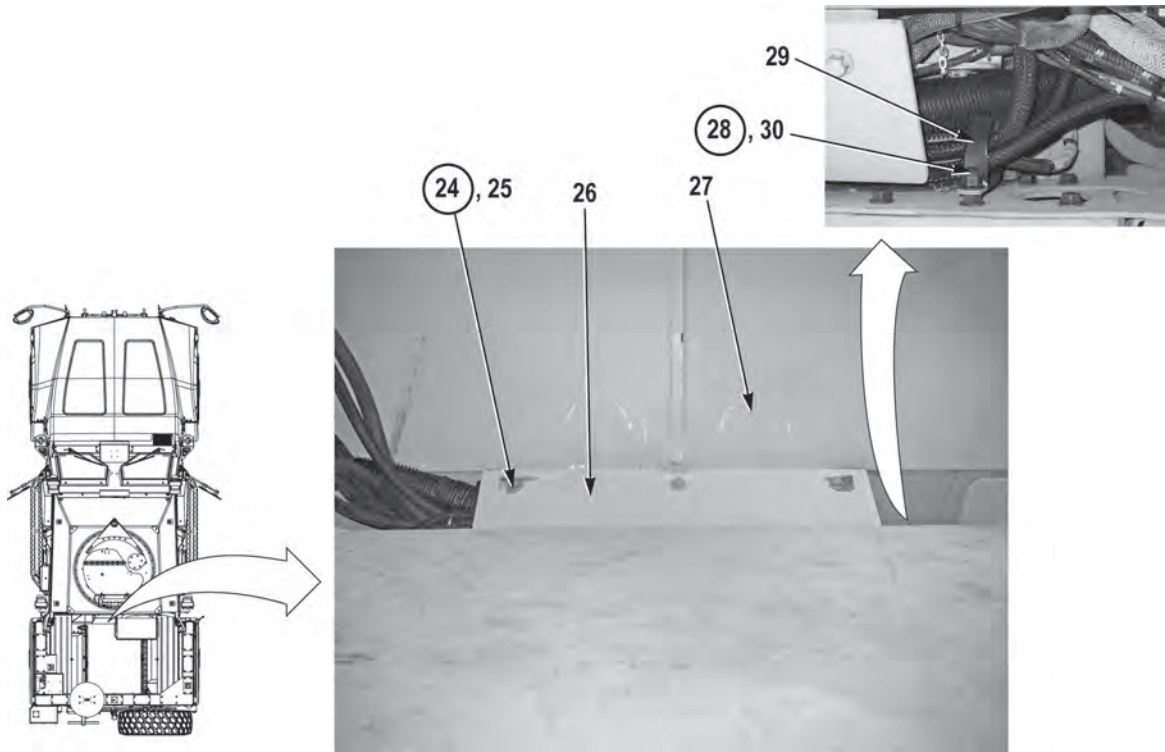

10. Remove three locknuts (24), screws (25), and cover (26) from capsule (27). Discard locknuts (24).
11. Remove locknut (28) and cushion clip (29) from stud (30). Discard locknut (28).

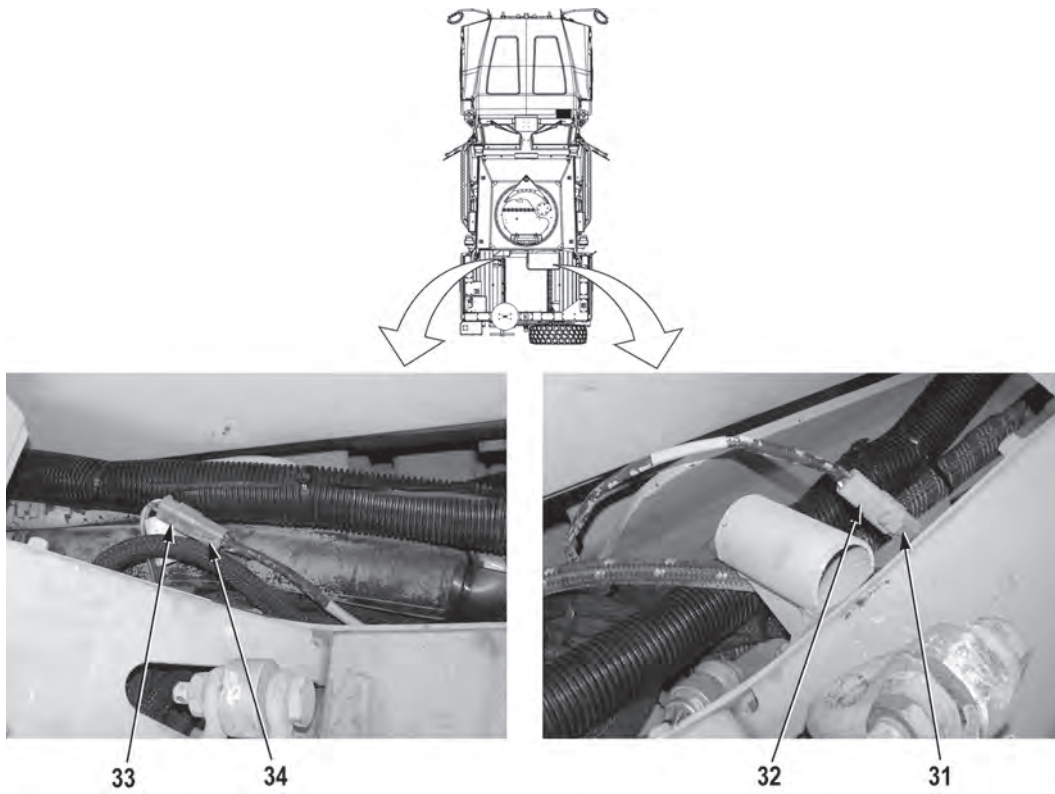

### NOTE

Note position and remove cable ties as required.

12. Disconnect passenger side adapter harness connector LOC1 (31) from tire harness connector C462 (32).
13. Disconnect driver side adapter harness connector LOC1 (33) from tire harness connector C461 (34).

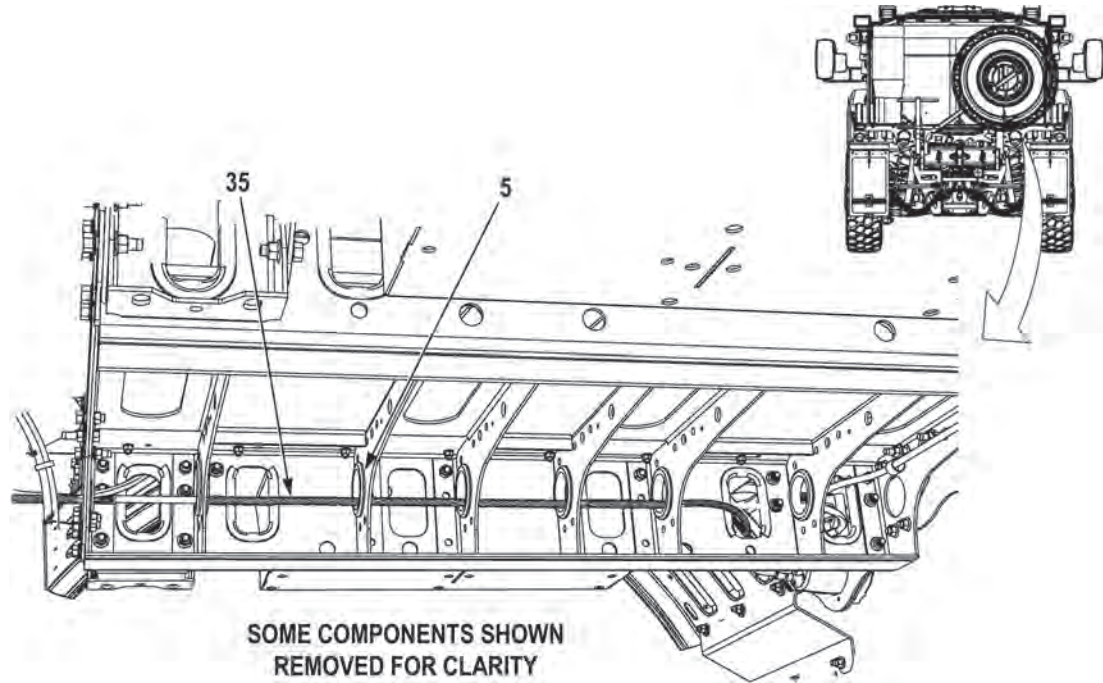

14. Remove passenger side Check-6 wire harness (35) from cargo deck (5).
15. Repeat Step (14) for driver side Check-6 wire harness.

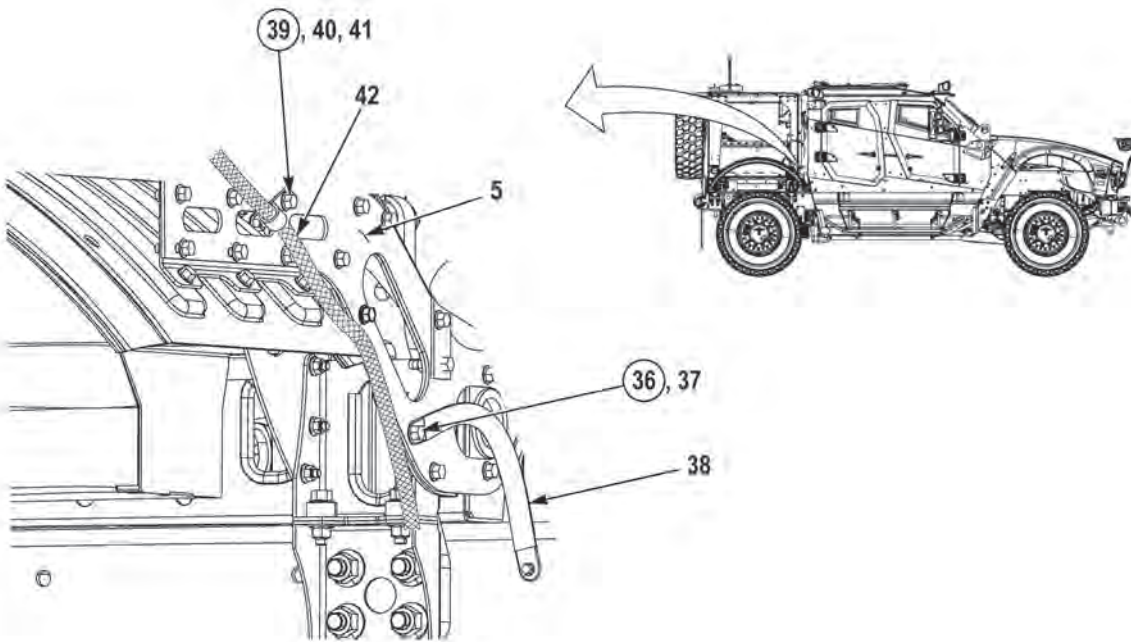
**NOTE**

- Note placement of ground straps prior to removal.
- Note position and remove cushion clips as required.

16. Remove locknut (36), screw (37), and ground strap (38) from cargo deck (5). Discard locknut (36).
17. Remove locknut (39), screw (40), and cushion clip (41) from cargo deck (5) and pull wire harness (42) away from cargo deck (5). Discard locknut (39).



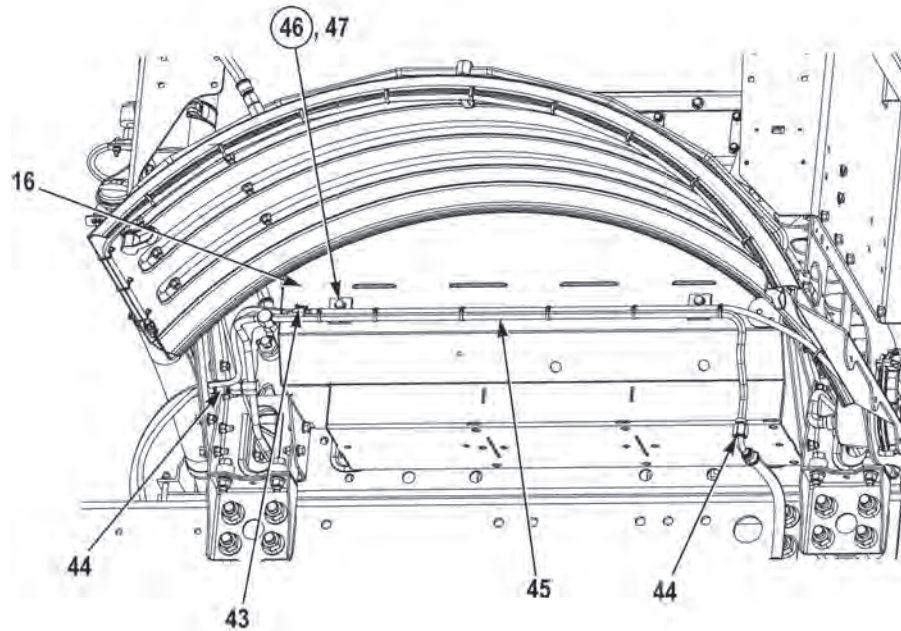

### NOTE

- Tag and mark connector prior to removal to ensure proper installation.
- Note position and remove cable ties as required.

18. Disconnect connector (43).
19. Remove three hoses (44) from tube (45).

### CAUTION

**Tube must be fully removed from tie down pass through prior to lifting cargo deck.  
Failure to comply may result in damage to equipment.**

20. Remove two locknuts (46), screws (47), and tube (45) from driver side battery box (16). Discard locknuts (46).

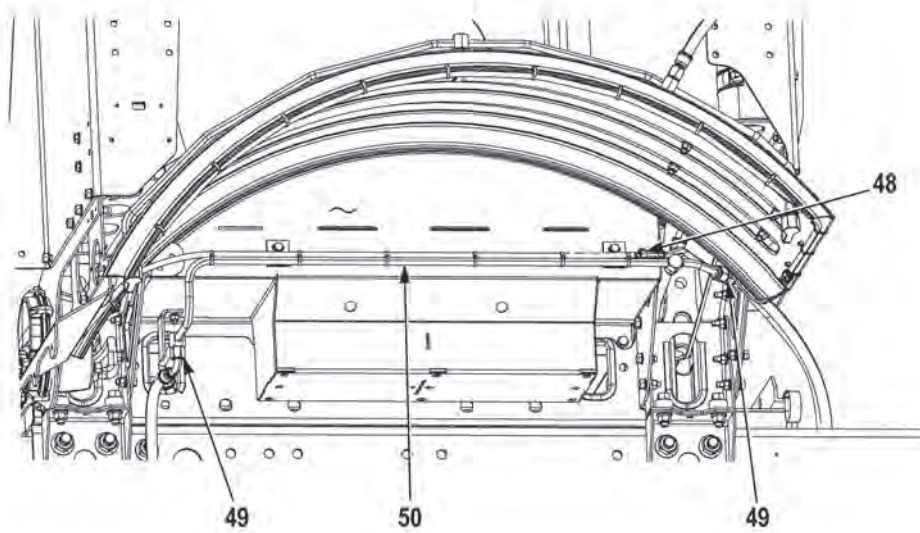
**NOTE**

- Tag and mark connector prior to removal to ensure proper installation.
- Note position and remove cable ties as required.

21. Disconnect connector (48).

22. Remove two hoses (49) from tube (50).

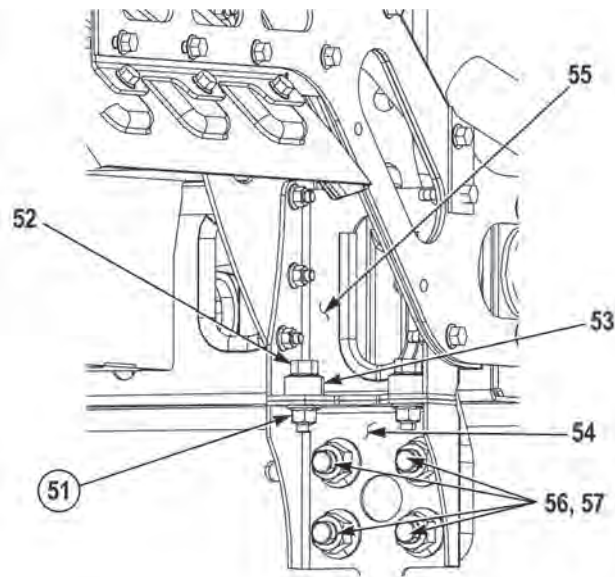
**NOTE**

- Note position of cargo deck mount hardware prior to removal to ensure proper installation.
- All cargo deck mount hardware is removed the same way. Passenger side front shown.

23. Remove two locknuts (51), screws (52), and spacers (53) on frame mount bracket (54) and cargo deck mount bracket (55). Discard locknuts (51).

**NOTE**

Spacers on M1240A1 may fall from behind front cargo deck mounts. Note position of spacers.

24. Loosen four locknuts (56) and screws (57) from frame mount bracket (54).
25. Repeat Steps (23) and (24) to remove hardware from three remaining mount points.

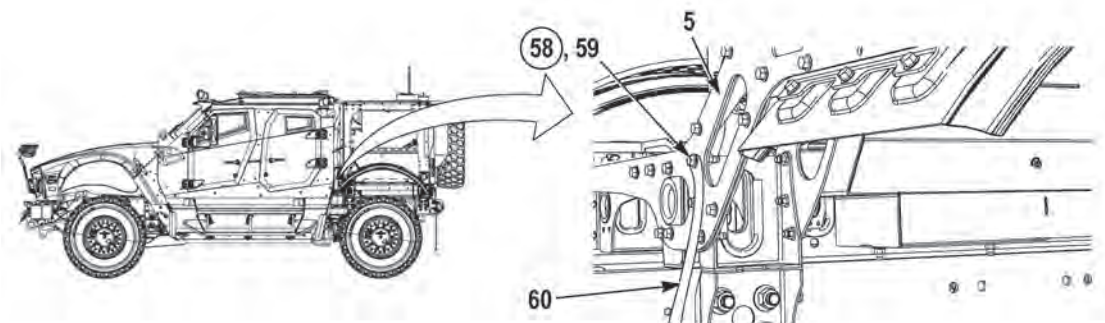
**NOTE**

Note position of ground strap prior to removal.

26. Remove locknut (58), screw (59), and ground strap (60) from cargo deck (5). Discard locknut (58).

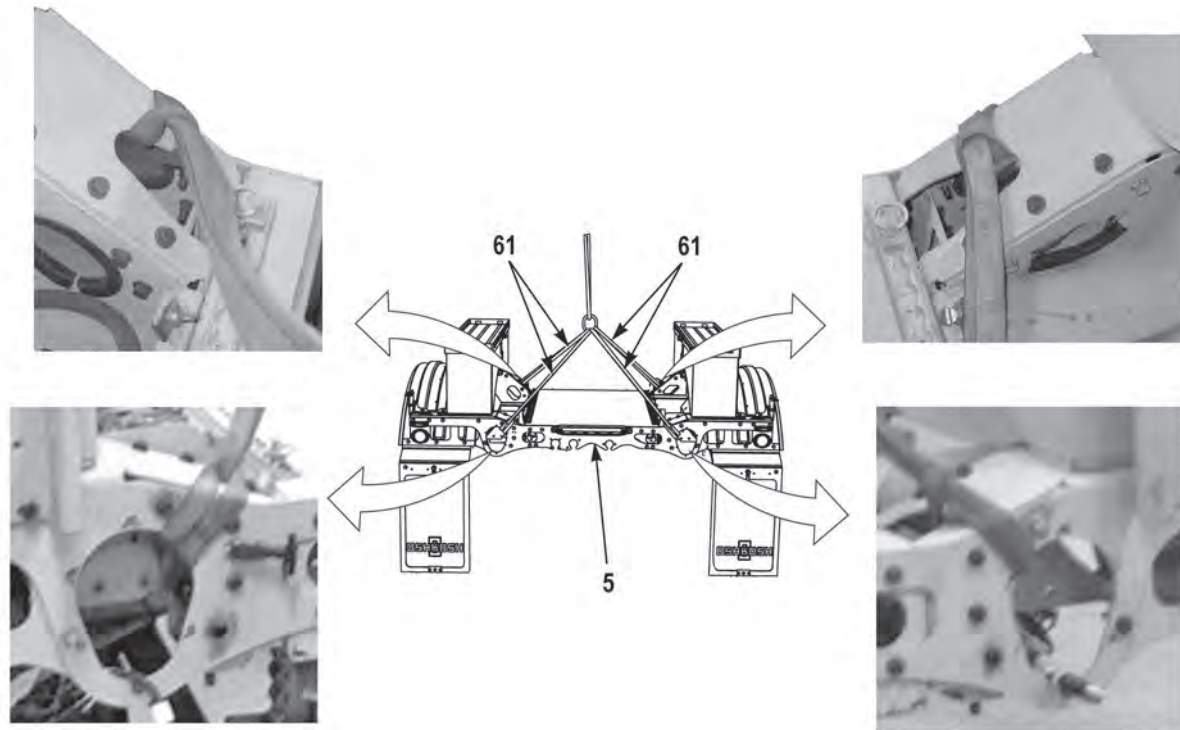

### **WARNING**

Cargo deck weighs 660 lbs (300 kg). Do not attempt to lift or move cargo deck without the aid of an assistant, lifting straps, and a lifting device. Failure to comply may result in injury or death to personnel.

### **CAUTION**

Use caution while removing cargo deck from vehicle. Ensure wire harness, fire suppression sensor wires, fire suppression lines, and Check-6 cables do not become caught or bound during removal. Failure to comply may result in damage to equipment.

### **NOTE**

Crow bar may be required to remove cargo deck.

27. With the aid of an assistant, attach lifting straps (61) and lifting device to cargo deck (5) as shown, and remove cargo deck (5) from vehicle.

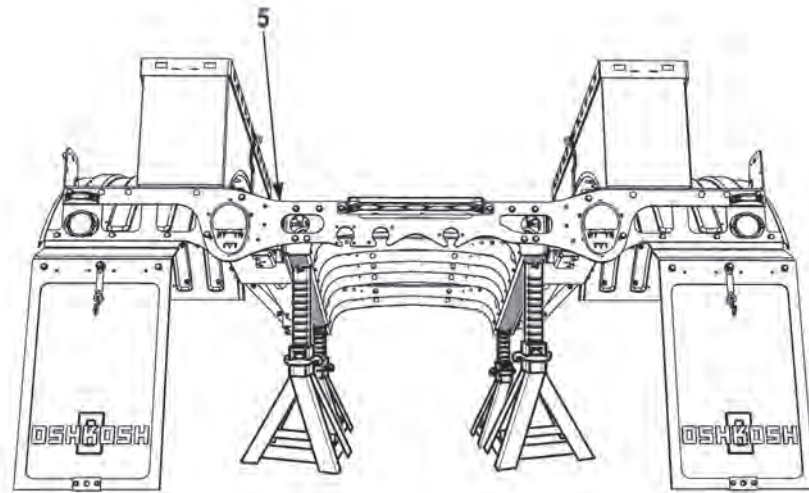

28. With the aid of an assistant and lifting device, position cargo deck (5) on four jack stands.

**END OF TASK**

## INSTALLATION

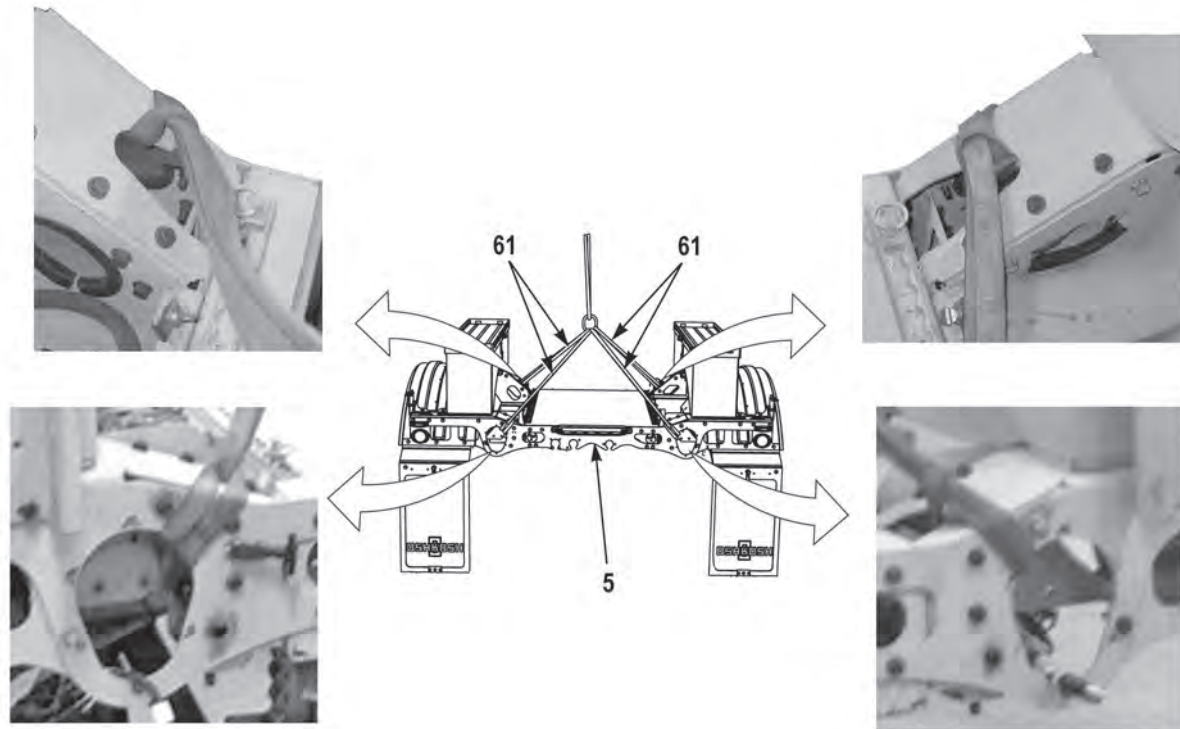

### **WARNING**

Cargo deck weighs 660 lbs (300 kg). Do not attempt to lift or move cargo deck without the aid of an assistant and a lifting device. Failure to comply may result in injury or death to personnel.

### **CAUTION**

- Ensure the rear light wire harness, fire suppression sensor wires, fire suppression lines, and Check-6 cables are properly routed prior to installing cargo deck on vehicle. Failure to comply may result in damage to equipment.
  - Use caution while installing cargo deck on vehicle. Ensure nothing becomes caught or bound during installation. Failure to comply may result in damage to equipment.
1. With the aid of an assistant and lifting device, attach four straps (61) to cargo deck (5) as shown, and position cargo deck (5) on vehicle.
  2. Remove four straps (61) and lifting device from cargo deck (5).



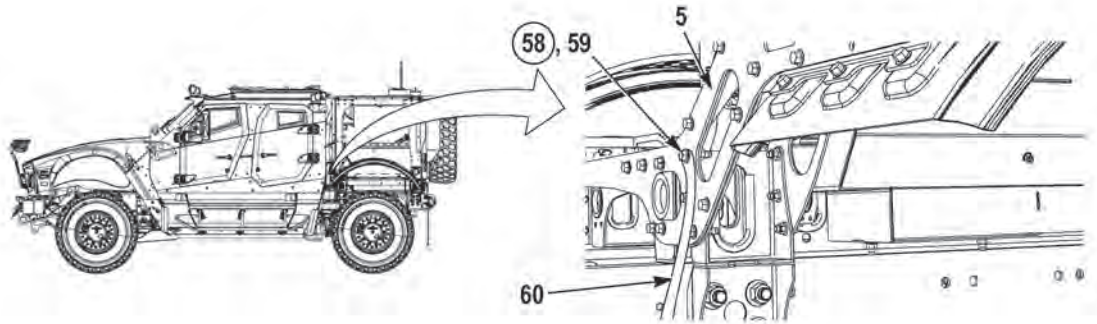

### **WARNING**

Adhesives, solvents, and sealing compounds can burn easily, can give off harmful vapors, and are harmful to skin and clothing. To avoid injury or death, keep away from open fire and use in well-ventilated area. If adhesive, solvent, or sealing compound gets on skin or clothing, wash immediately with soap and water. Failure to comply may result in injury or death to personnel.

### **NOTE**

- Install ground strap as noted prior to removal.
  - Ensure mating surface of cargo deck and ground strap is clean bare metal prior to installation.
3. Install ground strap (60) on cargo deck (5) with screw (59) and new locknut (58).
  4. Apply sealant, RTV, to screw (59), ground strap (60) and locknut (58).

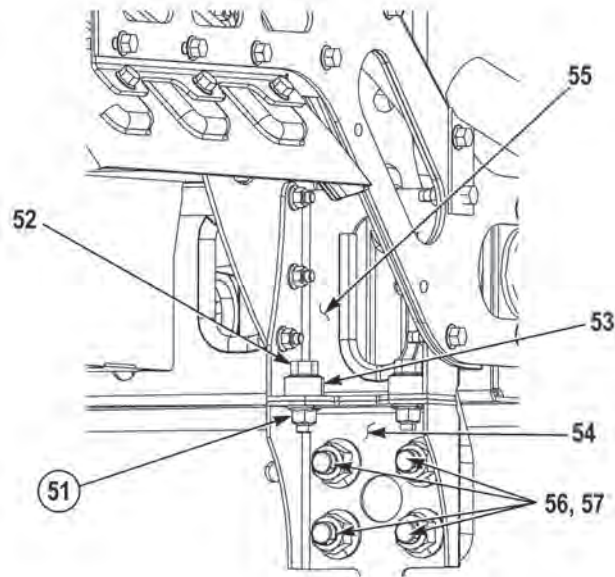
**NOTE**

- Install cargo deck mount hardware as noted prior to removal.
- All cargo deck mount hardware is installed the same way. Passenger side front shown.

5. Install cargo deck mount bracket (55) on frame mount bracket (54) with two spacers (53), screws (52), and new locknuts (51).

**NOTE**

Ensure spacers on M1240A1 front cargo deck mounts are secured prior to tightening hardware.

6. Tighten four screws (57) and locknuts (56) on frame mount bracket (54).
7. Repeat Steps (5) and (6) for three remaining mount points.

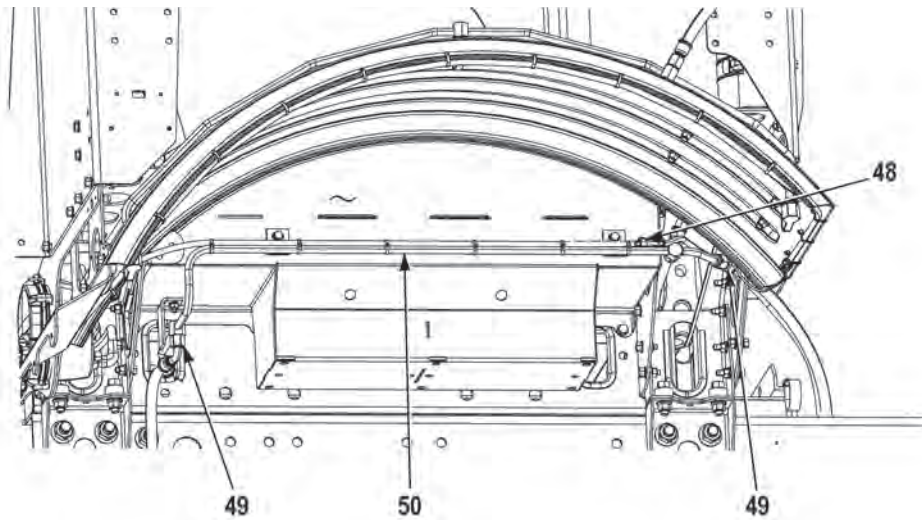
**NOTE**

Install cable ties as noted prior to removal.

8. Install two hoses (49) on tube (50).
9. Connect connector (48).

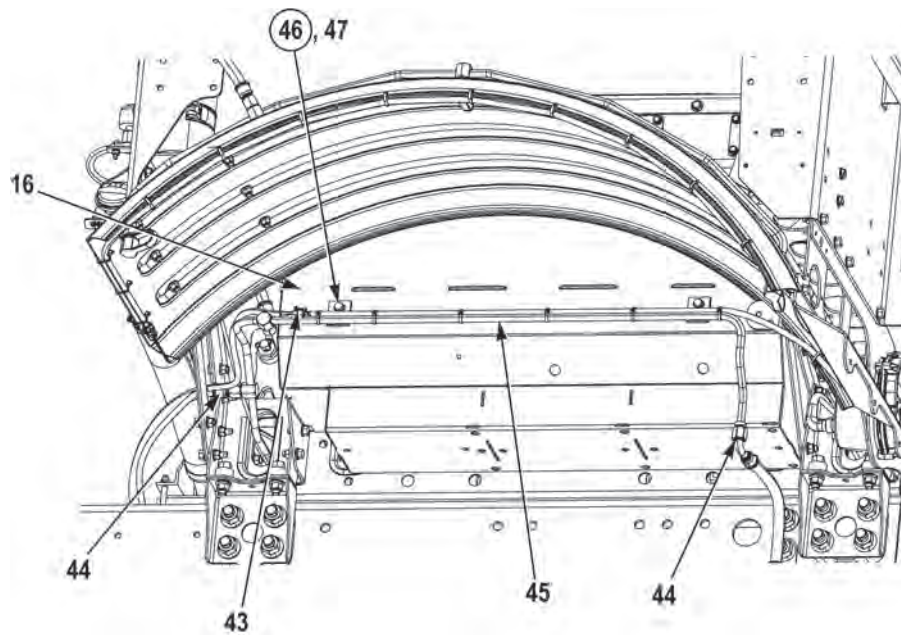
**NOTE**

Install cable ties as required.

10. Install tube (45) on driver side battery box (16) with two screws (47) and new locknuts (46).
11. Install three hoses (44) on tube (45).
12. Connect connector (43).

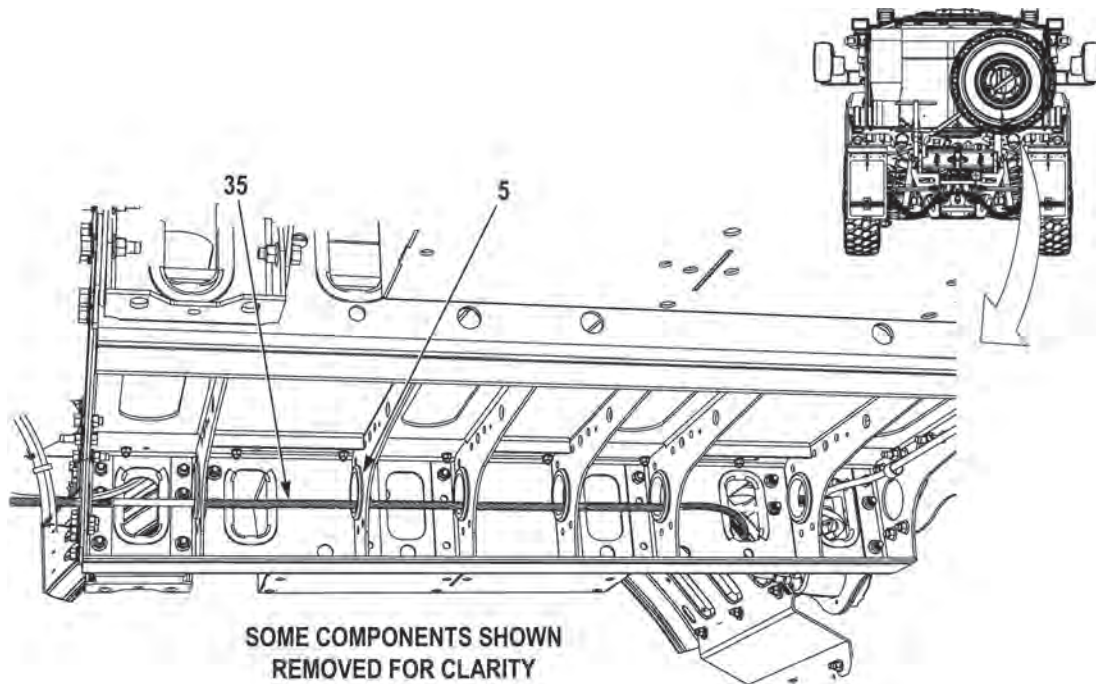

### NOTE

- Perform Steps (13) and (14) if vehicles is equipped with Check-6.
  - A crowbar may be used to assist in installation of Check-6 harness.
13. Route passenger side Check-6 wire harness (35) through cargo deck (5).
  14. Repeat Step (13) for drive side Check-6 wire harness.

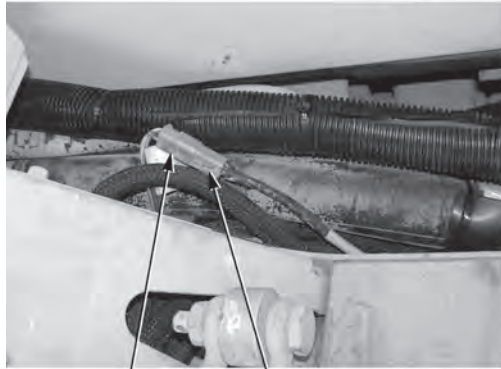
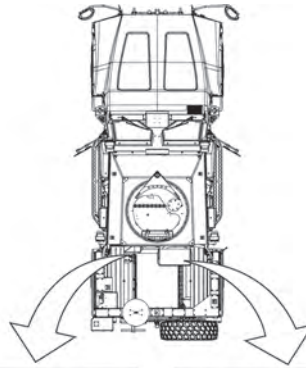

33

34

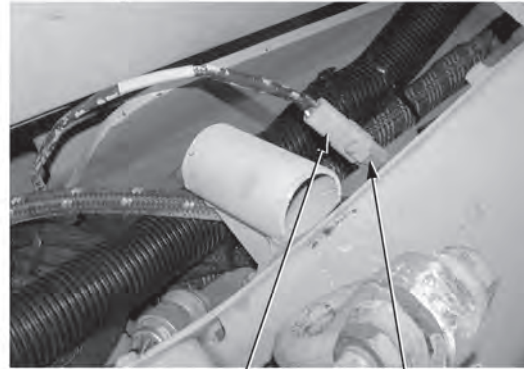

32

31

15. Connect connector C461 (34) to driver side adapter harness connector LOC1 (33).

#### NOTE

Install cable ties as noted prior to removal.

16. Connect connector C462 (32) to passenger side adapter harness connector LOC1 (31).



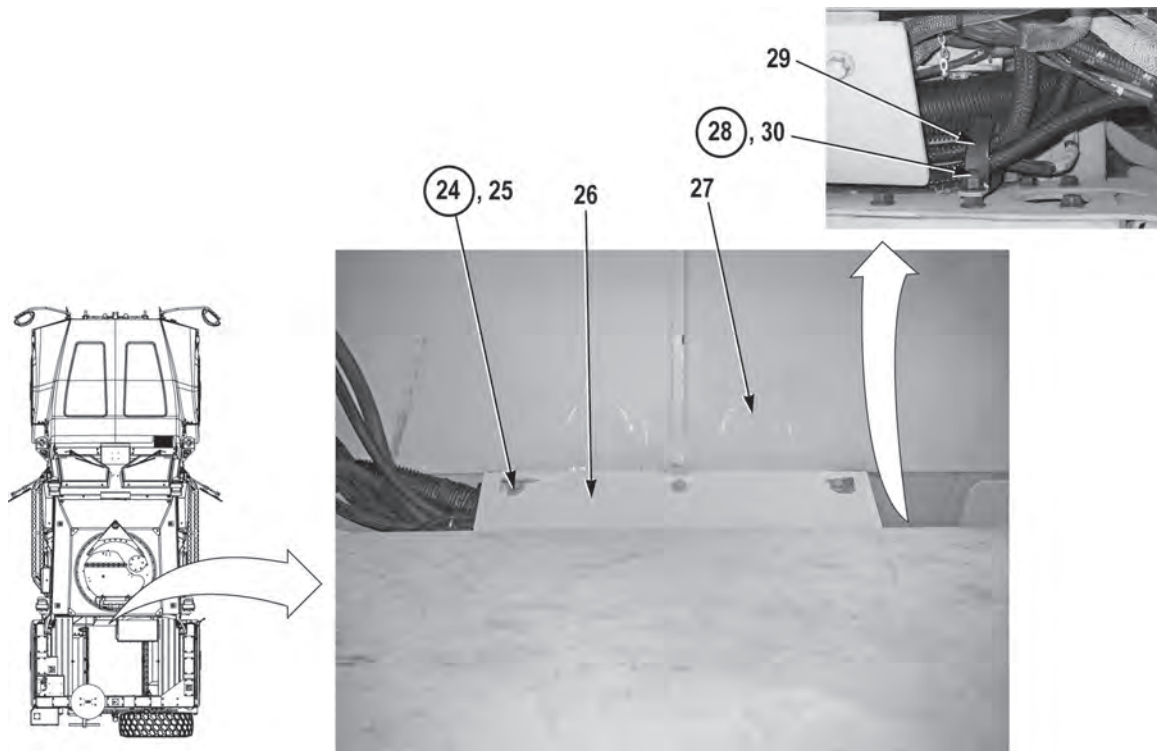

17. Install cushion clip (29) on stud (30) with new locknut (28).

**WARNING**

**Adhesives, solvents, and sealing compounds can burn easily, can give off harmful vapors, and are harmful to skin and clothing. To avoid injury or death, keep away from open fire and use in well-ventilated area. If adhesive, solvent, or sealing compound gets on skin or clothing, wash immediately with soap and water. Failure to comply may result in injury or death to personnel.**

18. Apply sealing compound, Loctite 242, to threads of three screws (25) and install cover (26) on capsule (27) with three screws (25) and new locknuts (24).

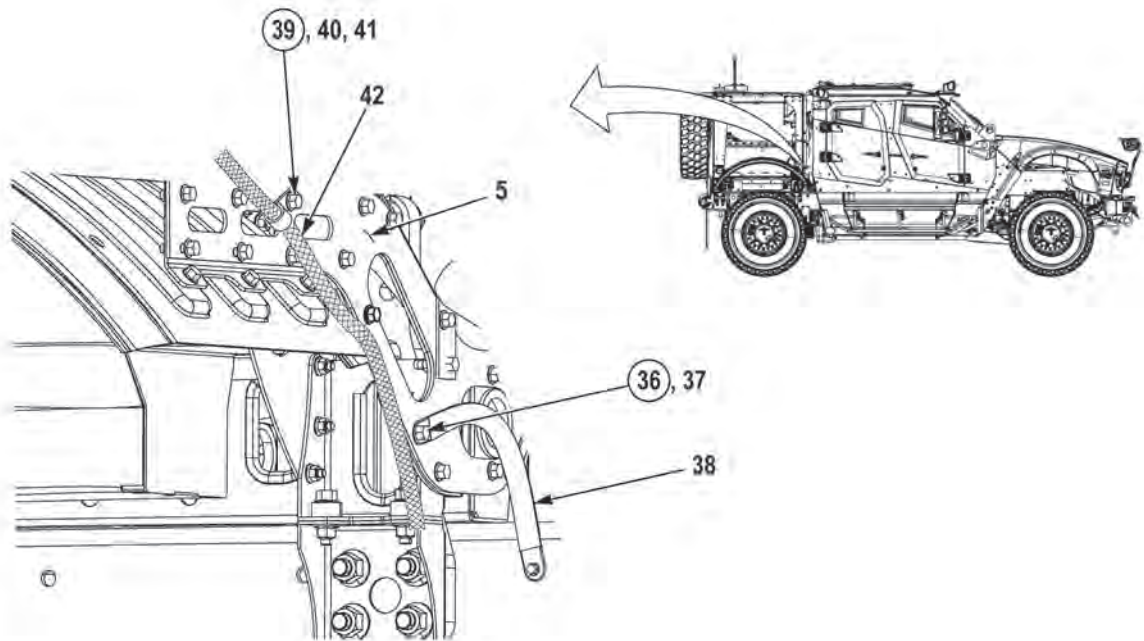

**NOTE**

Install cushion clips as noted prior to removal.

19. Install wire harness (42) on cargo deck (5) with cushion clip (41), screw (40), and new locknut (39).

**NOTE**

- Install ground strap as noted prior to removal.
- Ensure mating surface of cargo deck and ground strap is clean bare metal prior to installation.

20. Install ground strap (38) on cargo deck (5) with screw (37) and new locknut (36).

**WARNING**

**Adhesives, solvents, and sealing compounds can burn easily, can give off harmful vapors, and are harmful to skin and clothing. To avoid injury or death, keep away from open fire and use in well-ventilated area. If adhesive, solvent, or sealing compound gets on skin or clothing, wash immediately with soap and water. Failure to comply may result in injury or death to personnel.**

21. Apply sealant, RTV, to screw (37), ground strap (38), and locknut (36).

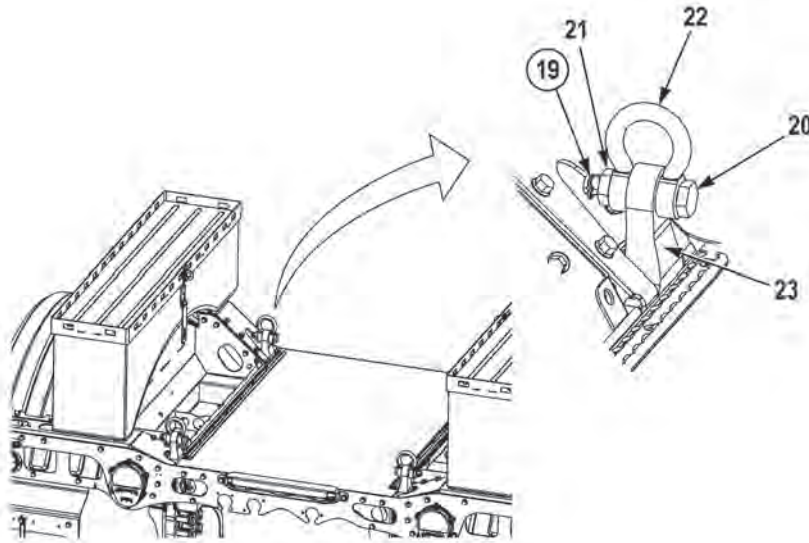
**NOTE**

All cargo deck shackles are installed the same way. Driver side front shackle shown.

22. Install shackle (22) on tie down bracket (23) with screw (20) and nut (21). Tighten nut (21) to 180 lb-in (20 N•m).
23. Install new cotter pin (19) on screw (20).
24. Repeat Steps (23) and (24) to install three remaining shackles.

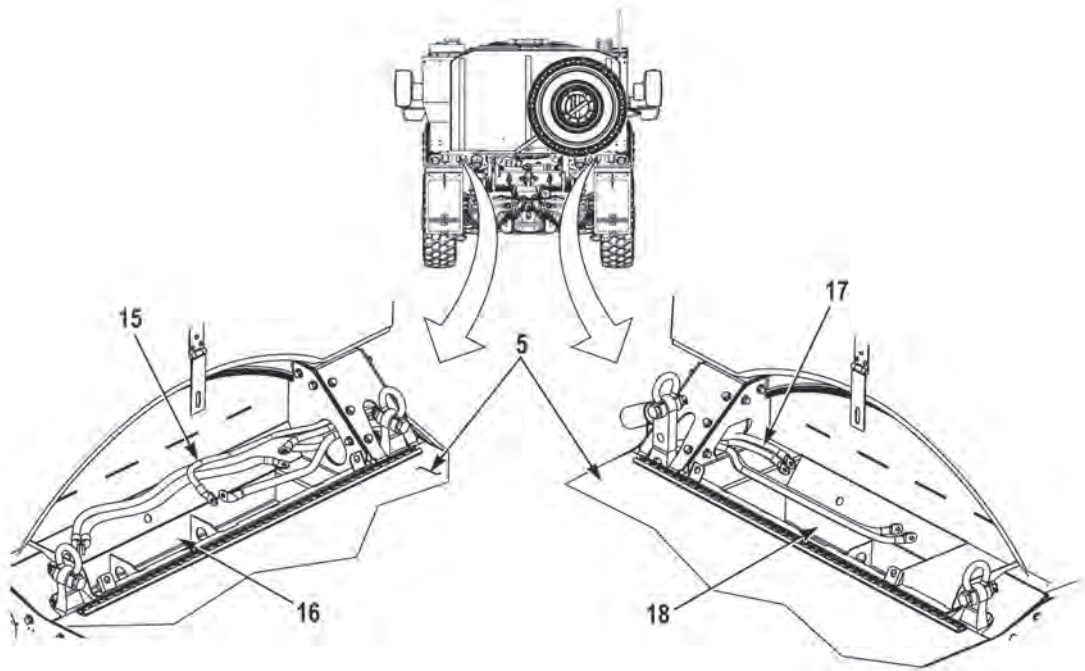
**NOTE**

Route and position battery cables as noted prior to removal.

25. Route passenger side battery cables (17) through cargo deck (5) and position in passenger side battery box (18).
26. Route driver side battery cables (15) through cargo deck (5) and position in driver side battery box (16).

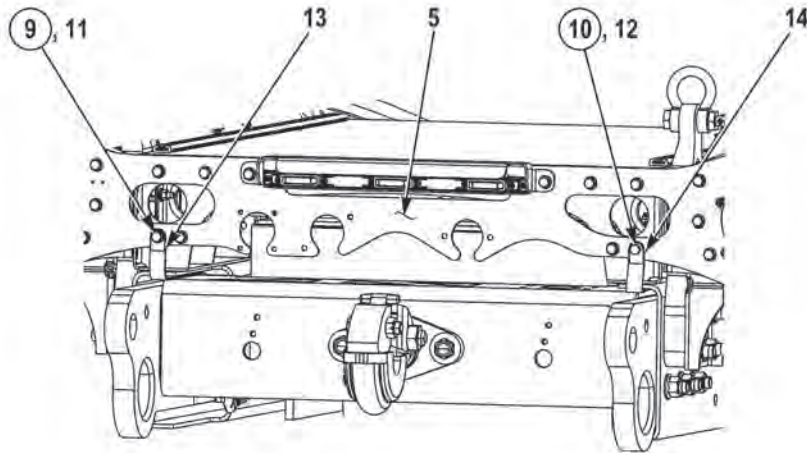

### NOTE

Ensure mating surface of cargo deck and ground straps are clean bare metal prior to installation.

27. Install two ground straps (14 and 13) on cargo deck (5) with two screws (12 and 11) and new locknuts (10 and 9).

### WARNING

**Adhesives, solvents, and sealing compounds can burn easily, can give off harmful vapors, and are harmful to skin and clothing. To avoid injury or death, keep away from open fire and use in well-ventilated area. If adhesive, solvent, or sealing compound gets on skin or clothing, wash immediately with soap and water. Failure to comply may result in injury or death to personnel.**

28. Apply sealant, RTV, to two screws (12 and 11), ground straps (14 and 13) and locknuts (10 and 9).

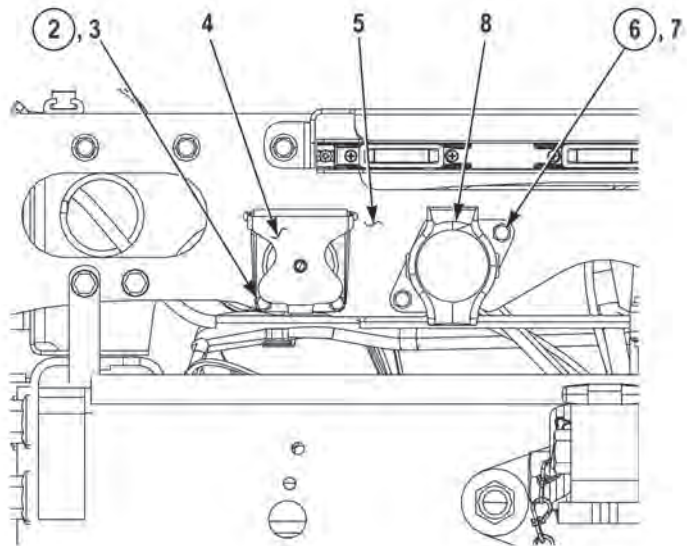

29. Install connector (8) on cargo deck (5) with two screws (7) and new locknuts (6).
30. Install connector (4) on cargo deck (5) with four screws (3) and new locknuts (2).

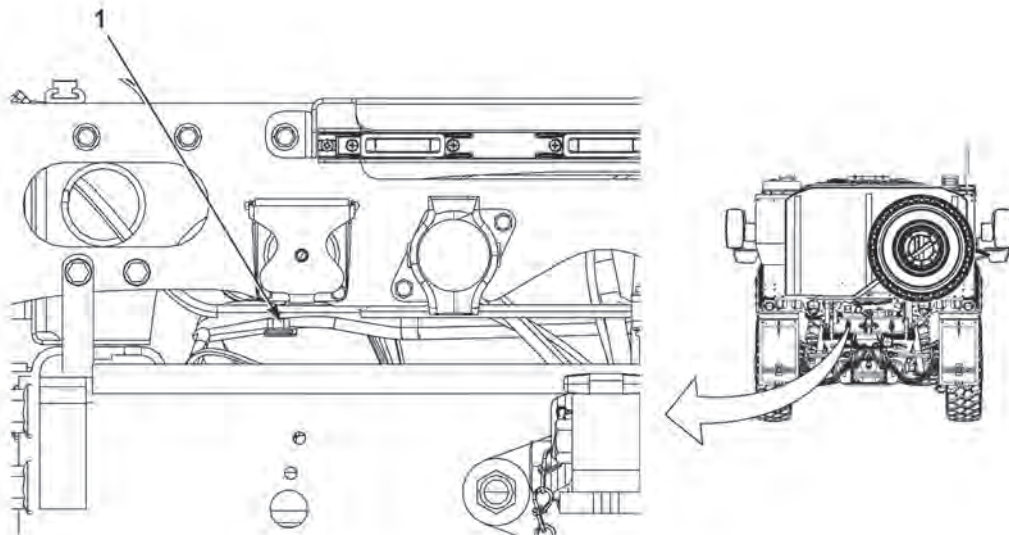

31. Connect connector (1).
32. Perform all Follow-On Maintenance tasks.

**END OF TASK**

**END OF WORK PACKAGE**





---

**CARGO DECK LITTER DOOR REPLACEMENT (M1245)**

---

**Preconditions**

Park Vehicle  
Engine OFF  
Wheels Chocked

**References**

Litter Door Operation (TM 9-2355-335-10)  
Litter Door Dyneema Panel Replacement  
(WP 0051)

**Tools and Special Tools**

Lifting Device  
Strap, 20 ft. (2)  
Single Stud Ring (4)  
Loctite Threadlocker  
Tool Kit, General Mechanic's: Automotive

**Follow-On Maintenance**

Remove and Stow Wheel Chocks

**Personnel Required**

Two

---

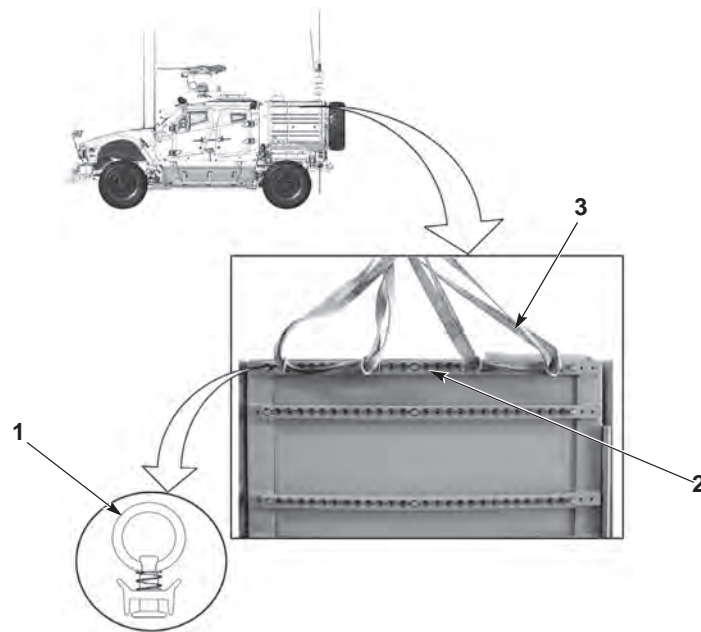
**REMOVAL****NOTE**

Procedure for the driver side and passenger side litter door removal are the same.

1. Install four single stud rings (1) evenly to the top tie down track (2), and attach two 20 ft. straps (3).

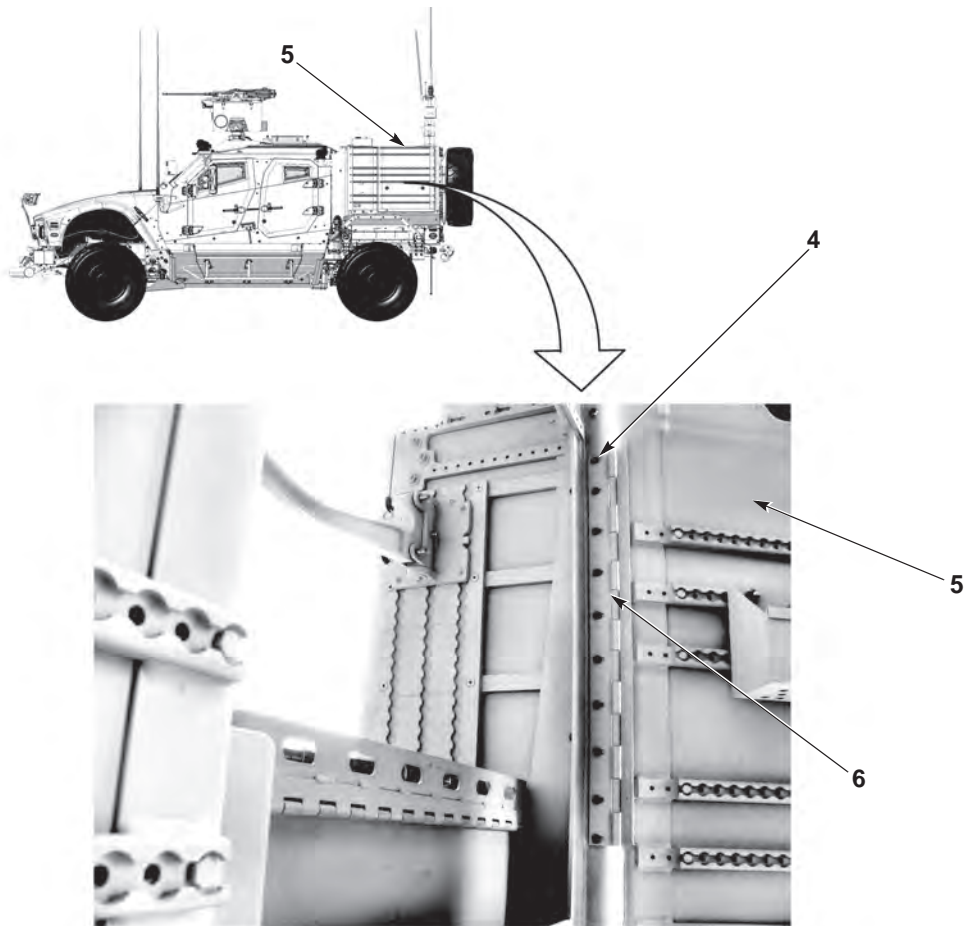
**REMOVAL – CONTINUED****WARNING**

- **Keep hands and fingers away from pinch point areas of litter doors. Hands and fingers could get pinched or crushed. Failure to comply may result in injury to personnel.**
- **Litter door assemblies for cargo deck weigh 142 lbs (65 kg). Do not attempt to lift or move assemblies without the aid of an assistant. Failure to comply may result in injury or death to personnel.**

2. Position the litter door (5) fully open.
3. With the aid of an assistant and lifting device, support the litter door (5).
4. Remove ten screws (4) from the litter door hinge (6).
5. With the aid of an assistant and lifting device, remove the litter door (5).

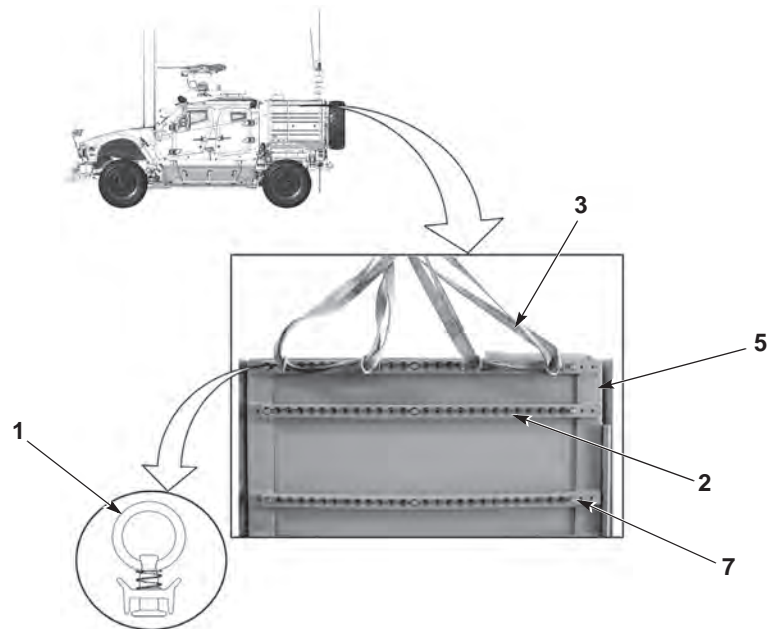
**REMOVAL – CONTINUED****NOTE**

For installation purposes, note the location, length and configuration of each tie down track strip prior to removal.

6. Remove 20 ft. straps (3), single stud rings (1) from the tie down track (2).
7. Remove screws (7) and remove tie down tracks (2) from the cargo deck litter door (5).
8. Remove dyneema panel from the litter door (WP 0051).

**END OF TASK**

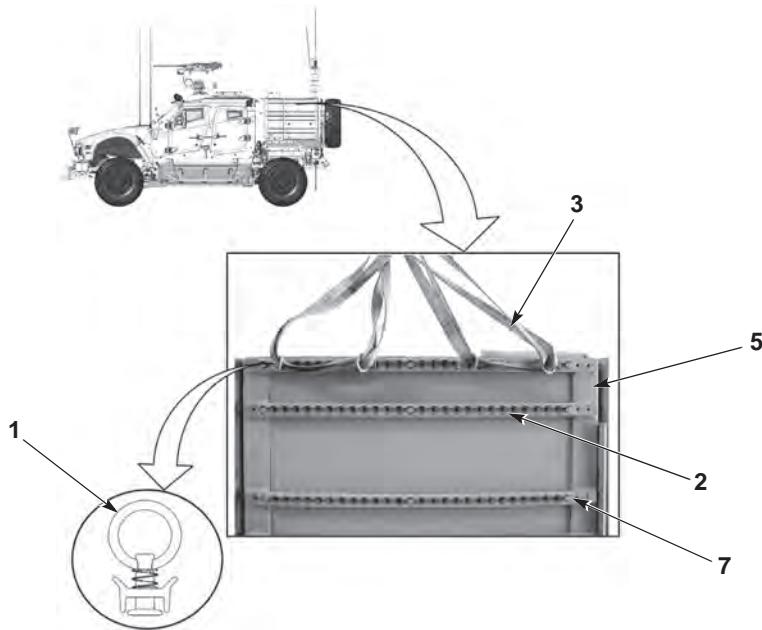
**INSTALLATION****NOTE**

- Procedure for the driver side and passenger side litter door installation are the same.
- Install tie down tracks as noted prior to removal.

1. Install the dyneema panel in litter door (WP 0051).
2. Apply loctite threadlocker to screws (7) and install tie down tracks (2) to cargo deck litter door (5).
3. Install four single stud rings (1) evenly to the top tie down track (2), and attach two 20 ft. straps (3).

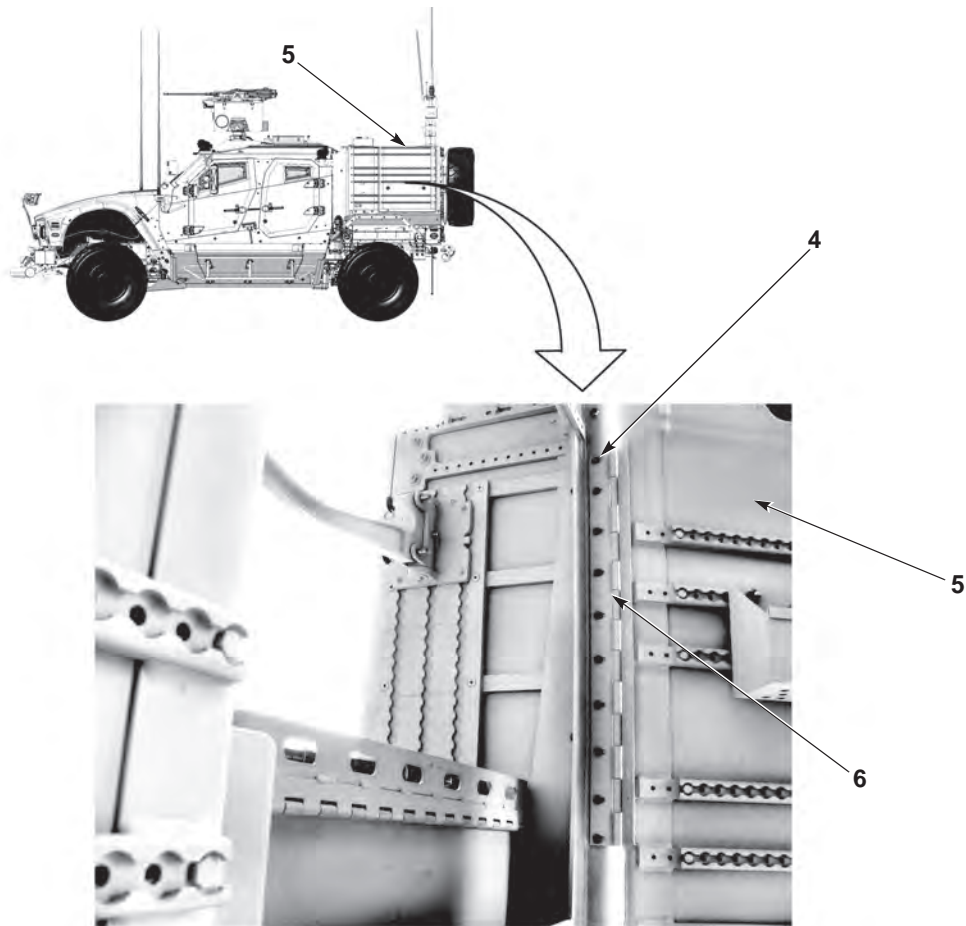
**INSTALLATION – CONTINUED****WARNING**

- **Keep hands and fingers away from pinch point areas of litter doors. Hands and fingers could get pinched or crushed. Failure to comply may result in injury to personnel.**
- **Litter door assemblies for cargo deck weigh 142 lbs (65 kg). Do not attempt to lift or move assemblies without the aid of an assistant. Failure to comply may result in injury or death to personnel.**

**NOTE**

Do not tighten hardware until final adjustments are made.

4. With the aid of an assistant and lifting device, position the litter door (5) next to the cargo deck.
5. Align the litter door hinge (6) to the cargo deck, and install ten screws (4).

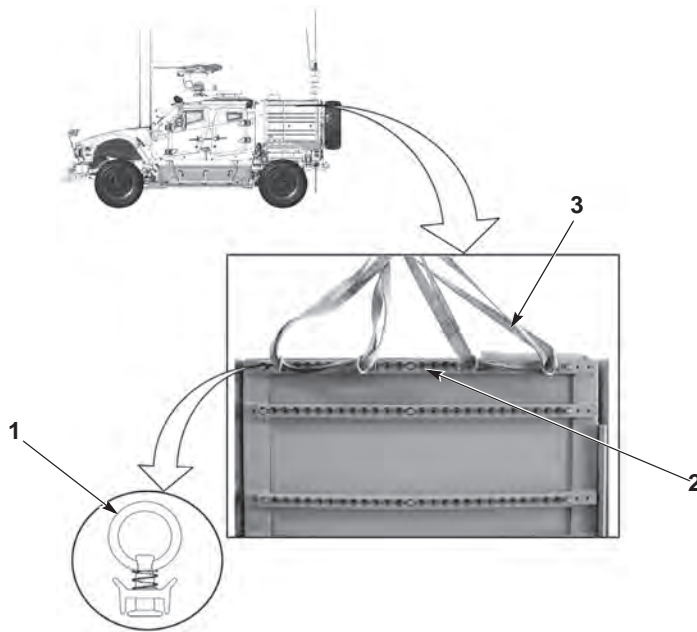
**INSTALLATION – CONTINUED**

6. Remove 20 ft. straps (3), single stud rings (1) from the tie down track (2).
7. Perform all Follow-On Maintenance Tasks.

**END OF TASK****END OF WORK PACKAGE**



---

**CARGO DECK LITTER DOOR FRAME REPLACEMENT (M1245)**

---

**Preconditions**

Park Vehicle  
 Engine OFF  
 Wheels Chocked  
 Litter Door Removed (WP 0245)  
 Driver Side GFE Cabinet Removed (WP 0252)  
 (perform only if removing driver side litter door).

**Tools and Special Tools**

Tool Kit, General Mechanic's: Automotive

**Materials/Parts**

Locknut (3) (Item 1)  
 Locknut (1) (Item 5)  
 Lockwasher (5) (Item 8)  
 Locknut (1) (Item 11)  
 Locknut (1) (Item 13)

**Personnel Required**

Two

**Follow-On Maintenance**

Install driver side GFE cabinet (WP 0252)  
 Install litter door (WP 0245)  
 Remove and stow wheel chocks

---

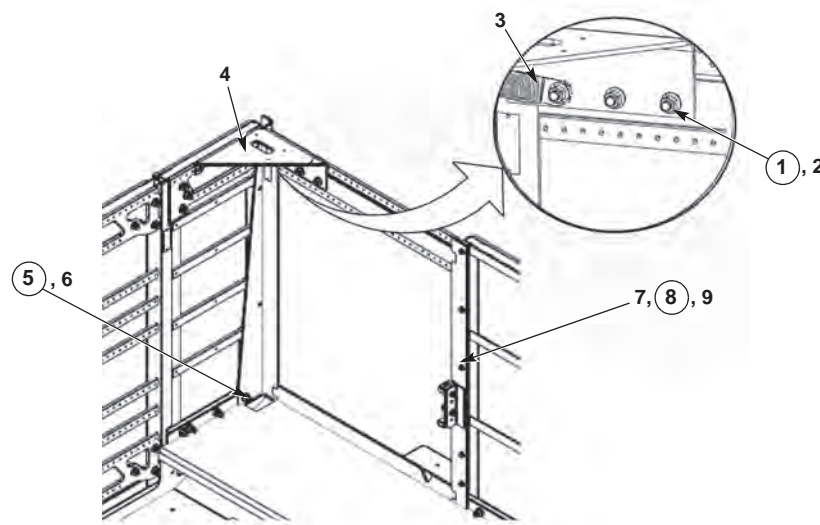
**REMOVAL****WARNING**

**Cargo deck litter door frame weighs 55 lbs (25 kg). Do not move cargo deck litter door frame without the aid of an assistant. Failure to comply may result in injury to personnel.**

**NOTE**

Driver side and passenger side cargo deck litter door frames are removed the same way.

1. Remove three locknuts (1) three screws (2) and grounding strap (3) from the antenna bracket (4). Discard locknuts (1).
2. Remove locknut (5) and screw (6). Discard locknut (5).
3. Remove five screws (7), five lockwashers (8), five washers (9). Discard lockwashers (8).

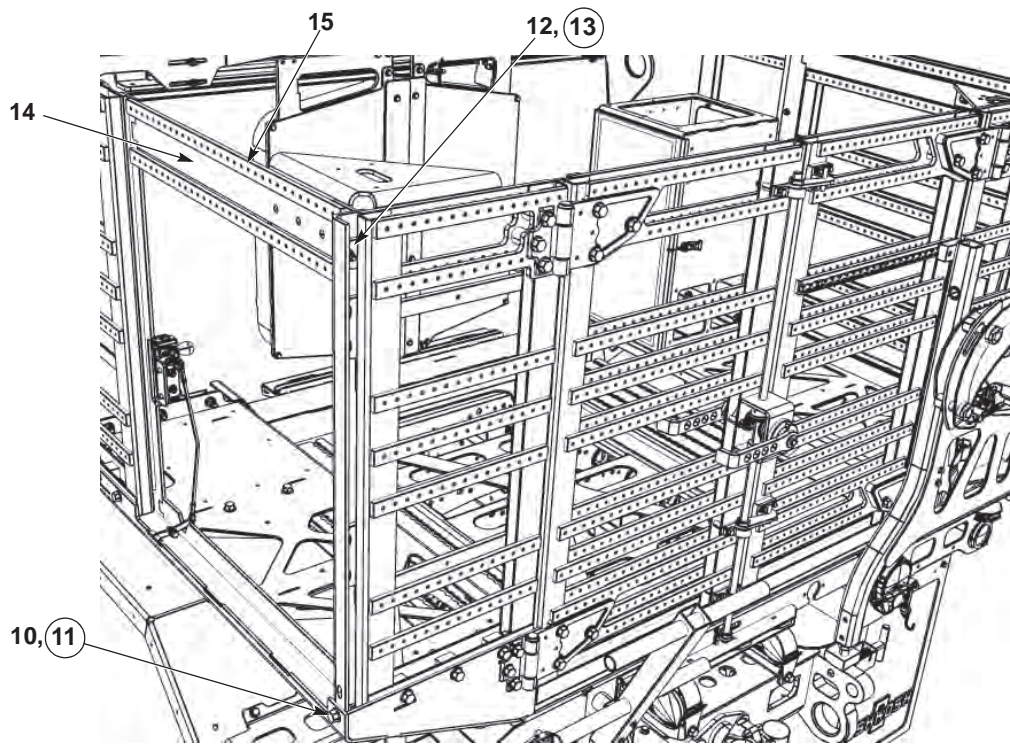
**REMOVAL – CONTINUED****NOTE**

For installation purposes, note the location, length and configuration of each tie down track strip prior to removal.

4. Remove screw (10) and locknut (11). Discard locknut.
5. Remove screw (12) and locknut (13). Discard locknut.
6. With the aid of an assistant lift cargo litter door frame (15) from cargo deck.
7. Remove tie down tracks (15) from the cargo litter door frame (14).

**END OF TASK**

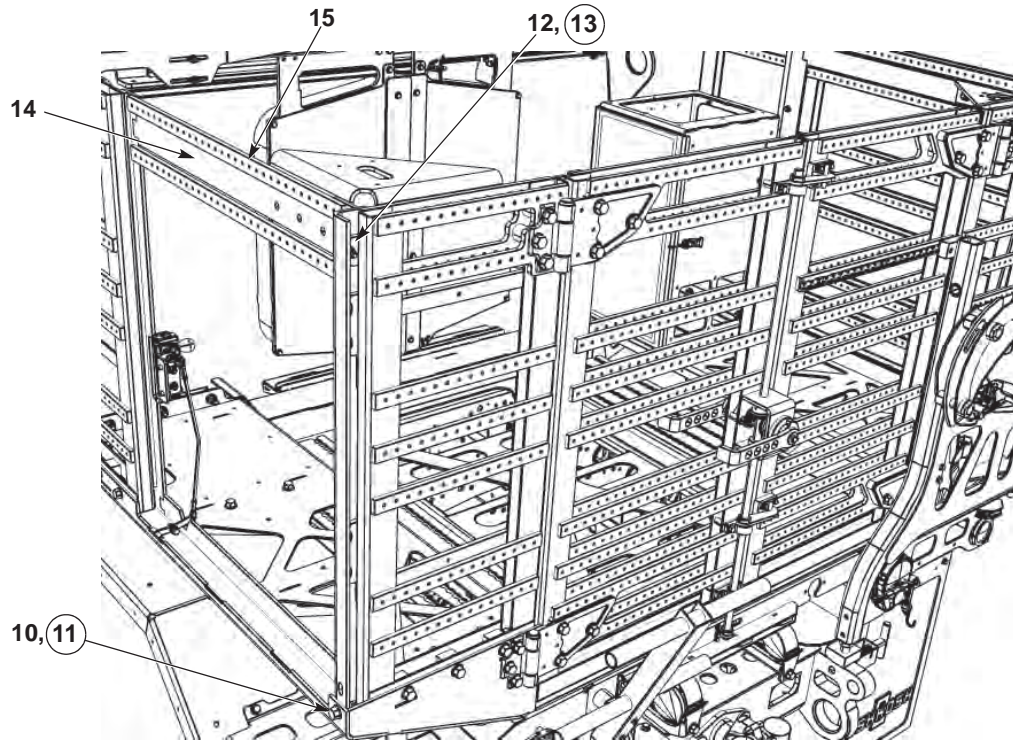
**INSTALLATION****WARNING**

**Cargo deck litter door frame weighs 55 lbs (25 kg). Do not move cargo deck litter door frame without the aid of an assistant. Failure to comply may result in injury to personnel.**

**NOTE**

- Driver side and passenger side cargo deck litter door frames are installed the same way.
  - Install tie down tracks as noted prior to removal.
1. Install tie down tracks (15) to the cargo litter door frame (14).
  2. With the aid of an assistant, position cargo deck litter door frame (14).
  3. Install screw (10) and new locknut (11).

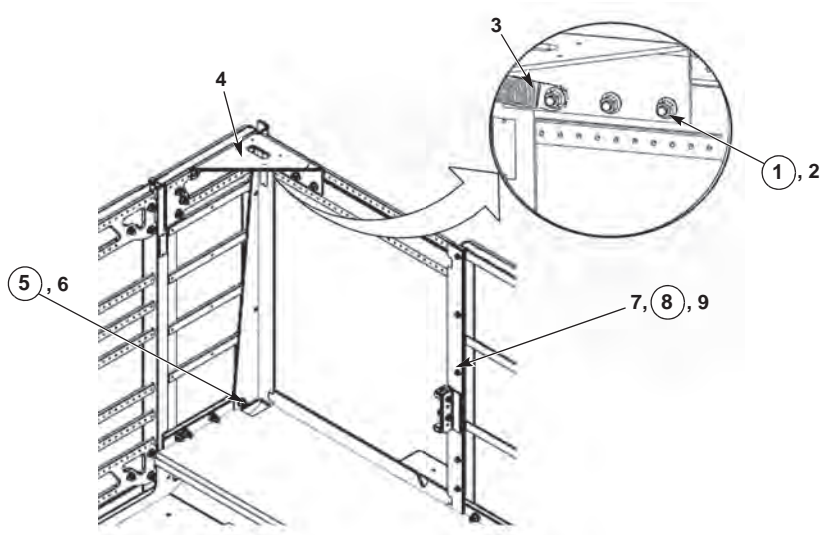
**INSTALLATION – CONTINUED**

4. Install five washers (9), five lockwashers (8) and five screws (7) to cargo deck litter door frame.
5. Install screw (6) and new locknut (5) to cargo deck litter door frame.
6. Attach grounding strap (3) and install three screws (2) and three new locknuts (1) to antenna bracket (4).
7. Perform all Follow-On Maintenance Tasks.

**END OF TASK**

**END OF WORK PACKAGE**



---

**CARGO DECK REAR WALL REPLACEMENT (M1245)**

---

**Preconditions**

Park Vehicle  
 Engine OFF  
 Wheels Chocked  
 Cargo Deck Rear Door Removed (WP 0248)  
 (Only remove the Rear Door that is mounted to Rear Wall being replaced).  
 Tire Carrier Removed (WP 0043) (Perform only when removing passenger side rear cargo wall).

**Materials/Parts**

Locknut (3) (Item 1)  
 Locknut (5) (Item 9)  
 Locknut (3) (Item 11)

**Tools and Special Tools**

Lifting Device

**Tools and Special Tools (continued)**

Strap, 20 ft. (2)  
 Single Stud Ring (2)  
 Loctite Threadlocker  
 Tool Kit, General Mechanic's: Automotive

**Personnel Required**

Two

**References**

Rear Wall Dyneema Panel Replacement Replacement (WP 0054)

**Follow-On Maintenance**

Install Cargo Deck Rear Door (WP 0248)  
 Install Tire Carrier (WP 0043)  
 Remove and Stow Wheel Chocks

---

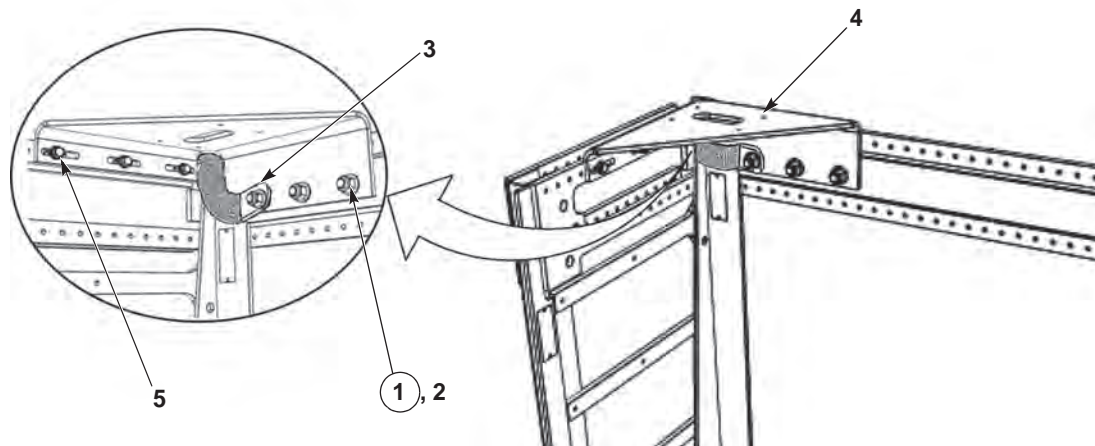
**CARGO DECK REAR WALL REMOVAL**
**NOTE**

Driver side and passenger side antenna brackets are removed the same way.

1. Remove three locknuts (1), three screws (2) and grounding strap (3) from antenna bracket (4). Discard locknuts (1).
2. Remove three screws (5) and remove antenna bracket (4).

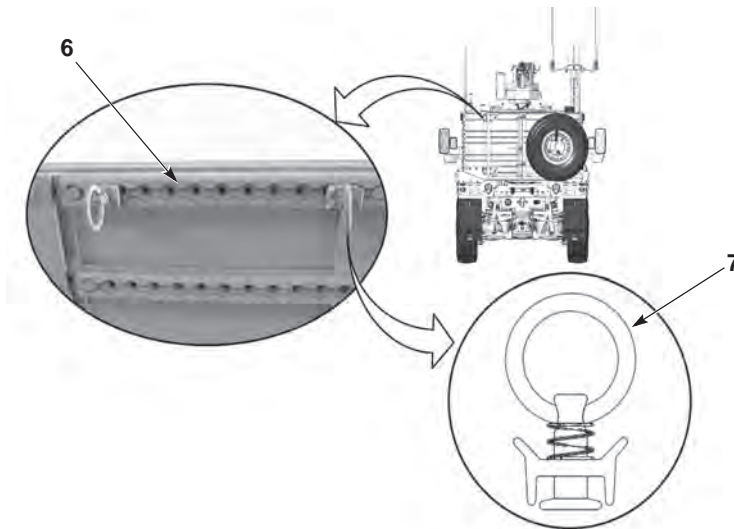
**REMOVAL – CONTINUED****WARNING**

Rear wall assemblies for cargo deck weigh 90 lbs (41 kg). Do not attempt to lift or move assemblies without the aid of an assistant. Failure to comply may result in injury or death to personnel.

**NOTE**

Removal procedure for the driver side and passenger rear wall the same.

3. Install two single stud rings (7) evenly to the top tie down track (6), and attach a 20 ft. strap.



## REMOVAL – CONTINUED

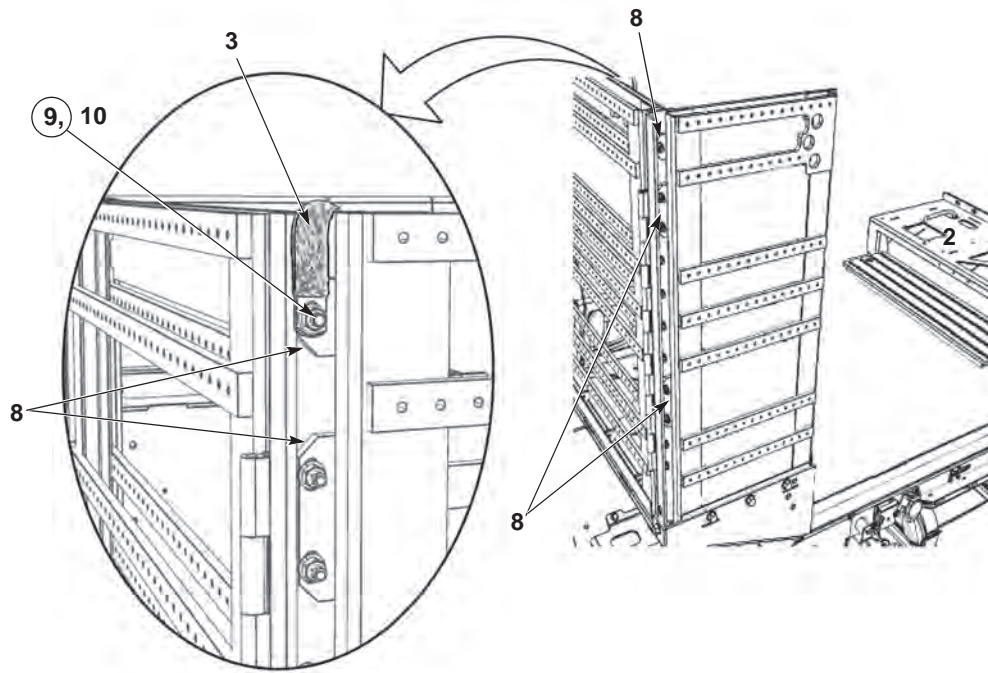

4. Locate the three rear wall brackets (8) and remove five locknuts (9), screws (10) and grounding strap (3). Discard locknuts (9).

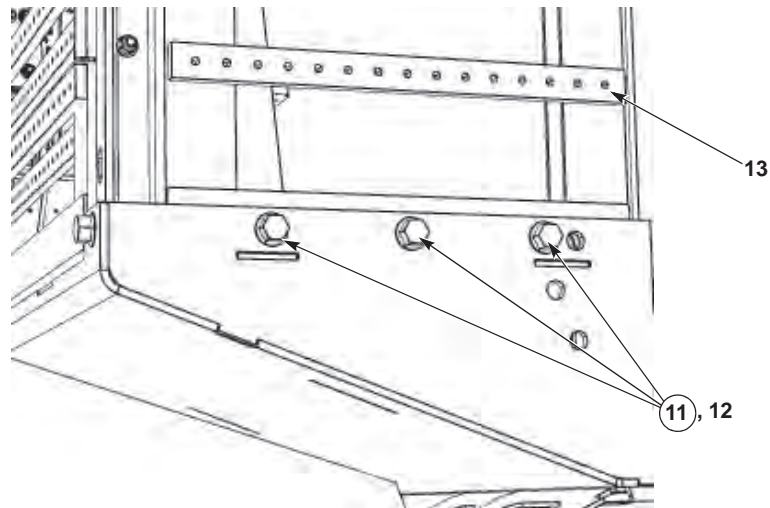
**REMOVAL – CONTINUED**

5. With the aid of an assistant and lifting device, support rear wall (13).
6. Remove three locknuts (11) and three screws (12) from the rear wall (13). Discard locknuts (11).
7. With the aid of an assistant and lifting device, remove the rear wall (13).

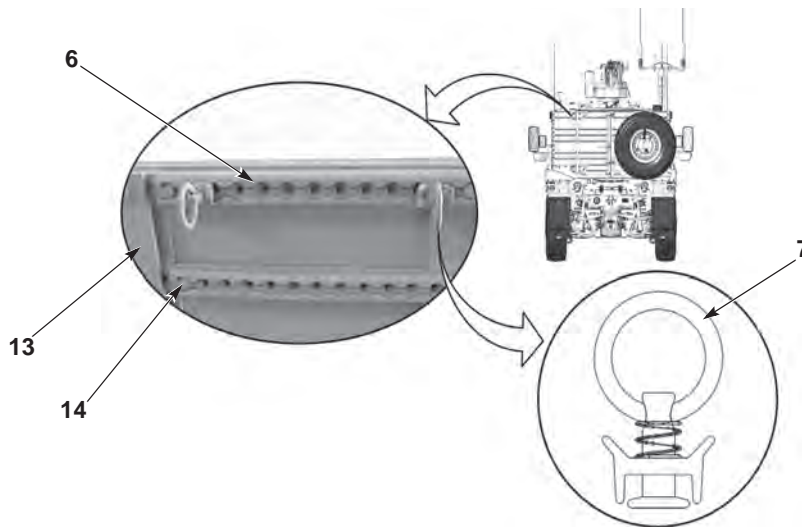
**NOTE**

For installation purposes, note the location, length and configuration of each tie down track strip prior to removal.

8. Remove 20 ft. strap, single stud rings (7) from the tie down track (6).
9. Remove screws (14) and remove tie down tracks (6) from the cargo deck rear wall (13).
10. Remove rear wall dyneema panel. (WP 0054).

**END OF TASK**

## INSTALLATION

1. Install rear wall dyneema panel. (WP 0054).

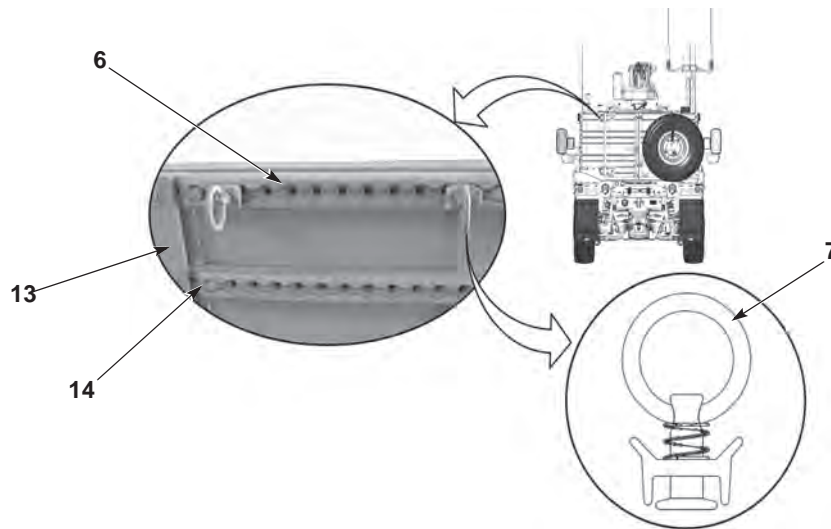

### **WARNING**

**Rear wall assemblies for cargo deck weigh 90 lbs (41 kg). Do not attempt to lift or move assemblies without the aid of an assistant. Failure to comply may result in injury or death to personnel.**

### **NOTE**

- Installation procedure for the driver side and passenger rear walls the same.
  - Install tie down tracks as noted prior to removal.
2. Apply loctite threadlocker to screws (14) and install tie down tracks (6) to cargo deck rear wall (13).
  3. Install two single stud rings (7) evenly to the top tie down track (6), and attach 20 ft. strap.
  4. With the aid of an assistant and lifting device, install the rear wall (13).

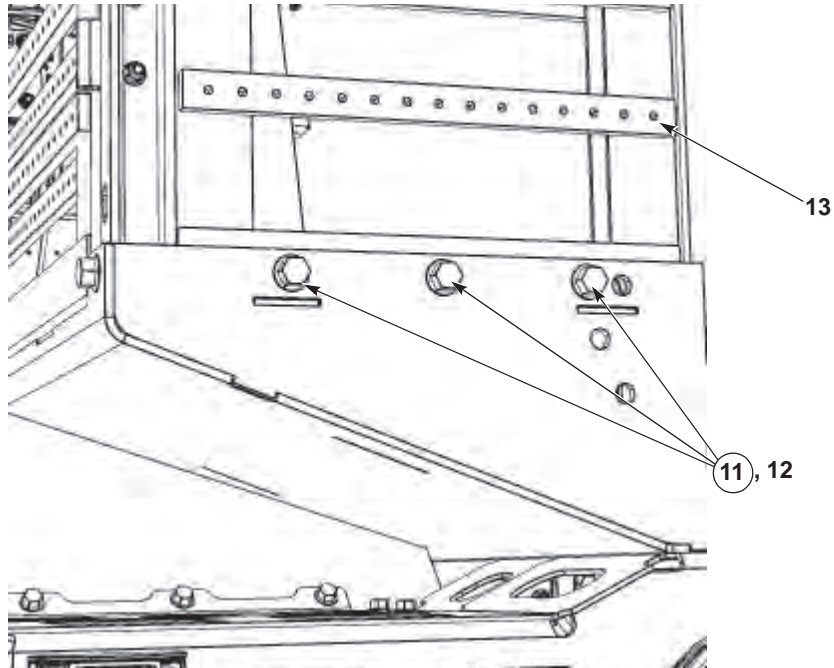
**INSTALLATION – CONTINUED****NOTE**

Do not tighten mounting hardware until final adjustments can be made.

5. Install three screws (12) and three new locknuts (11) to the lower portion of the rear wall (13).

**INSTALLATION – CONTINUED**

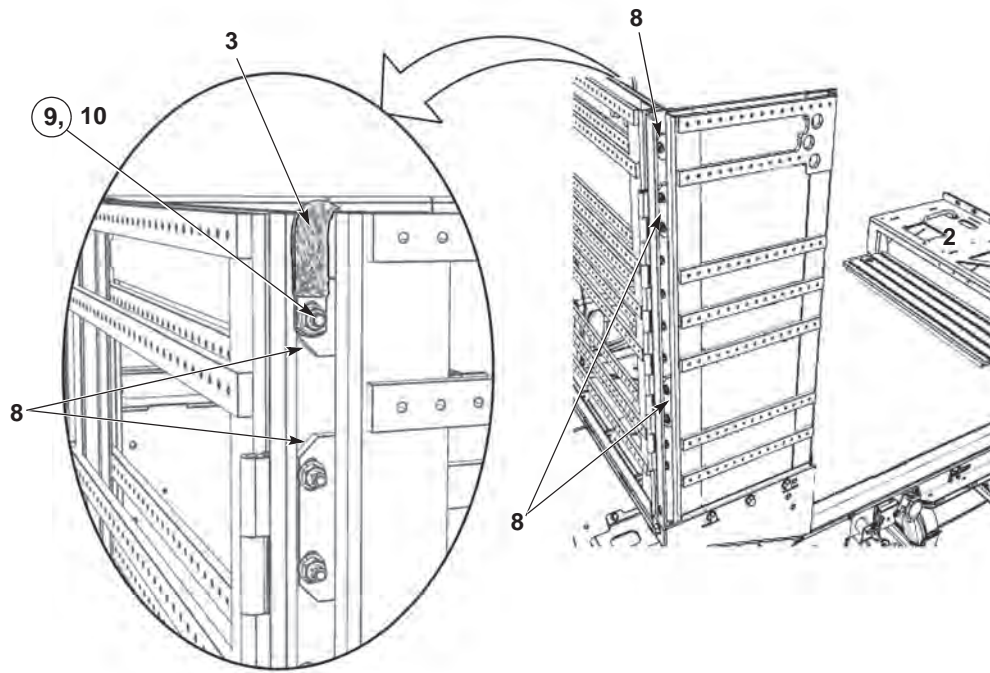

6. Install five screws (10) and five new locknuts (9), and grounding strap (3) to the rear wall brackets (8).

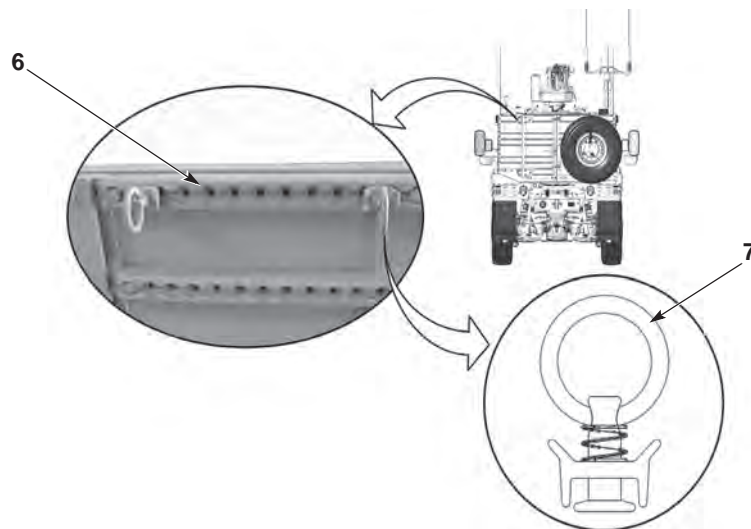

7. Remove 20 ft. strap, single stud rings (7) from the tie down track (6).

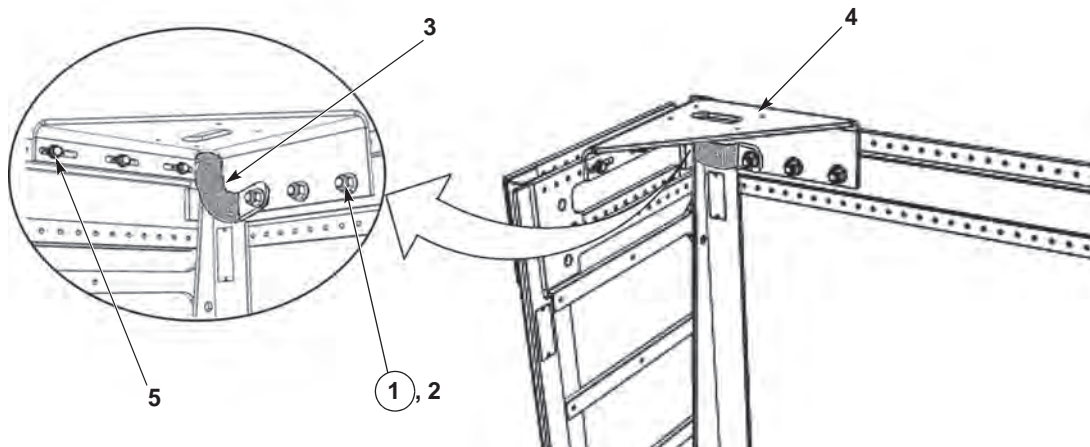
**INSTALLATION – CONTINUED**

8. Install the antenna bracket (4), position grounding strap (3), and secure with three screws (2) and three new locknuts (1).
9. Install three screws (5) securing the antenna bracket to the rear wall.
10. Perform all Follow-On Maintenance Tasks.

**END OF TASK****END OF WORK PACKAGE**



---

**CARGO DECK REAR DOOR REPLACEMENT (M1245)**

---

**Preconditions**

Park Vehicle  
 Engine OFF  
 Wheels Chocked  
 Rear Cargo Doors Operation (TM 9-2355-335-10)

**Tools and Special Tools**

Lifting Device  
 Strap, 20 ft. (2)  
 Single Stud Ring (4)  
 Compound Sealing, Loctite 242  
 Tool Kit, General Mechanic's: Automotive

**Materials/Parts**

Locknut (12) (Item 6)

**Materials/Parts (Continued)**

Locknut (8) (Item 10)  
 Locknut (4) (Item 11)  
 Locknut (6) (Item 25)

**Personnel Required**

Two

**References**

Rear Cargo Door Dyneema Panel Replacement (WP 0053)  
 Stow and Unstow Spare Tire (TM 9-2355-335-10)

**Follow-On Maintenance**

Rear Cargo Doors Operation (TM 9-2355-335-10)  
 Remove and Stow Wheel Chocks

---

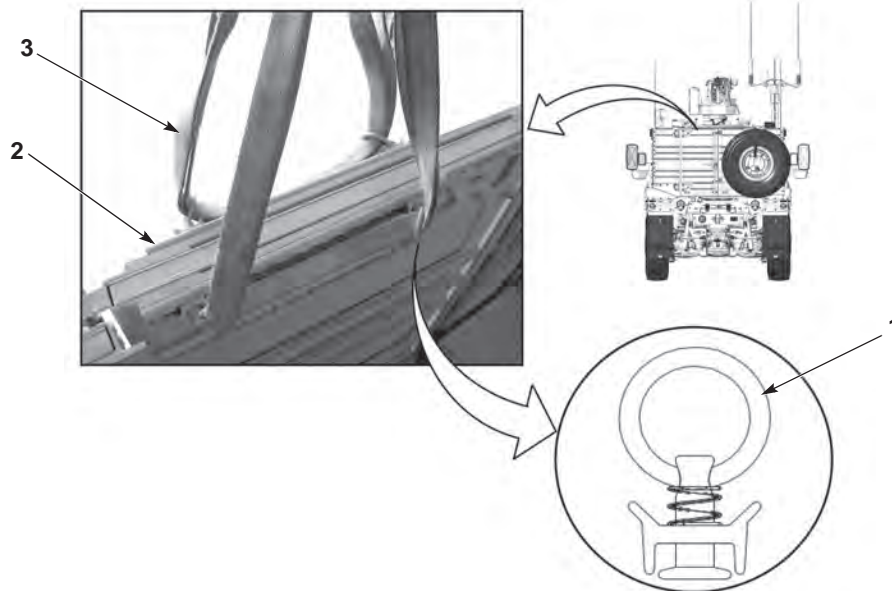
**DRIVER SIDE REAR CARGO DOOR REMOVAL**

1. Install four single stud rings (1) evenly to the top tie down track (2), and attach two 20 ft. straps (3).

## REMOVAL – CONTINUED

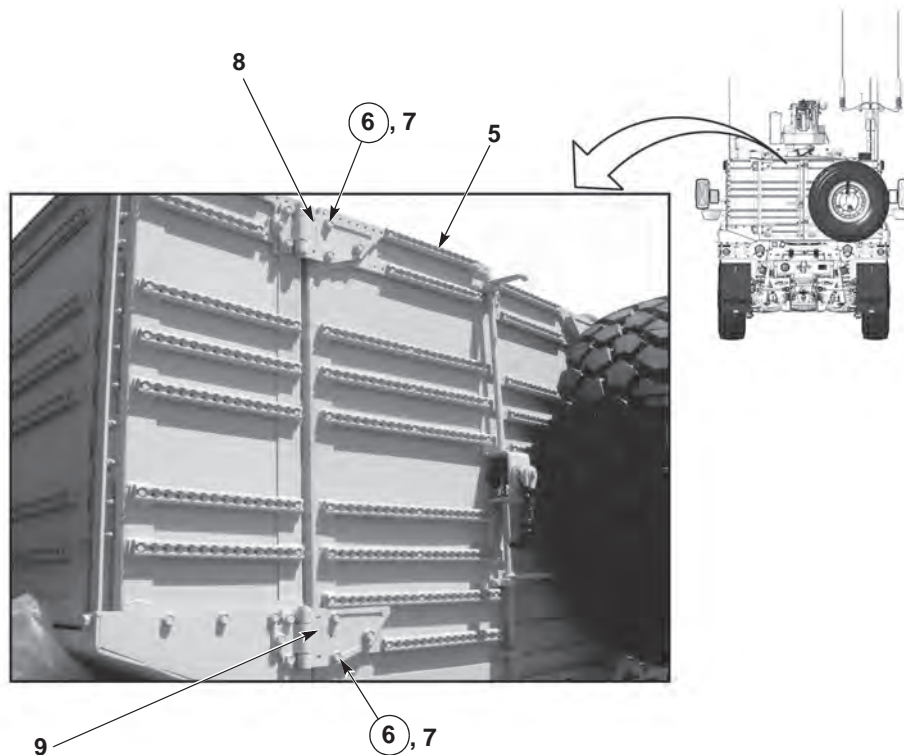
**WARNING**

- Keep hands and fingers away from pinch point areas of litter doors. Hands and fingers could get pinched or crushed. Failure to comply may result in injury to personnel.
- Driver side door assembly weighs 185 lbs (84 kg) and passenger side door assembly weighs 170 lbs (77 kg). Do not attempt to lift or move assemblies without the aid of an assistant and a lifting device. Failure to comply may result in injury or death to personnel.

2. With the aid of an assistant and lifting device, support the cargo door (5).
3. Remove six locknuts (6) and six screws (7) from the upper and lower cargo door hinges (8). Discard locknuts (6).
4. With the aid of an assistant and lifting device, remove the cargo door (5).

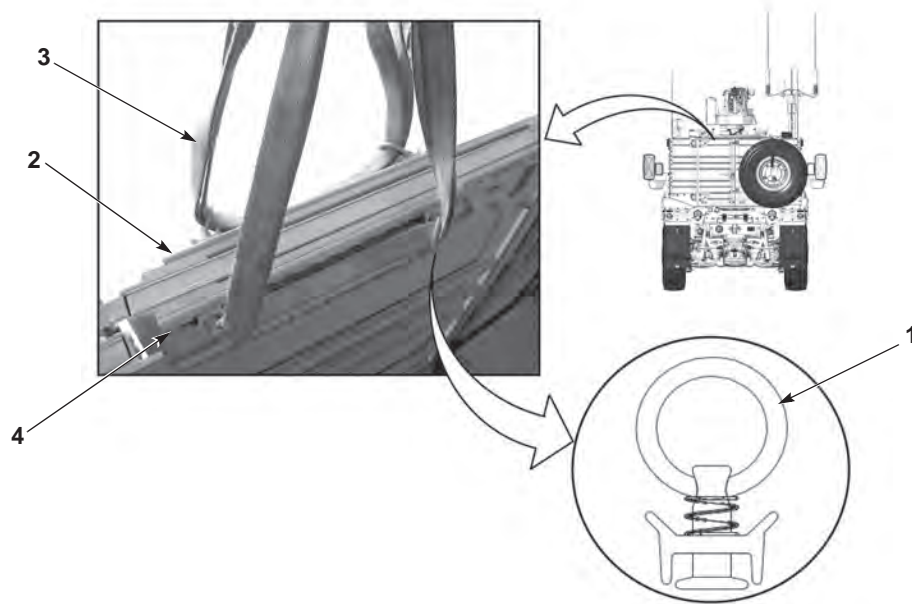
**REMOVAL – CONTINUED****NOTE**

For installation purposes, note the location, length, and configuration of each tie down track strip prior to removal.

5. Remove the 20 ft. straps (3) and four single stud rings (1) from the top tie down track (2).
6. Remove screws (4) and tie down tracks (2) from rear cargo door (5).

**END OF TASK**

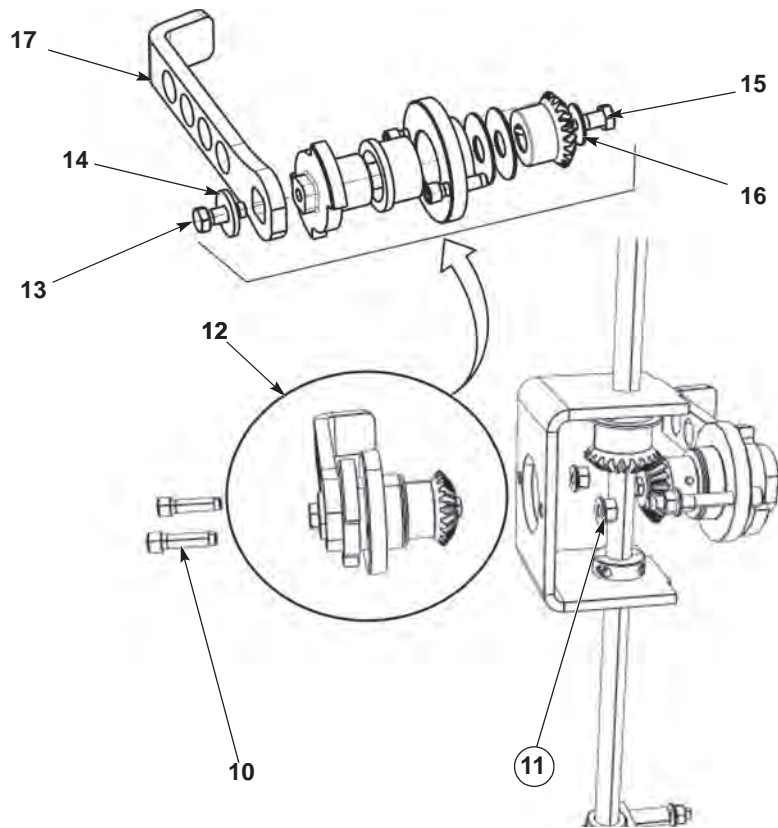
**DISASSEMBLY****NOTE**

Procedure to remove the rear cargo door handles will be the same for the inside and outside rear cargo door handles.

1. Remove two locknuts (11) and two screws (10), and remove handle assembly (12). Discard locknuts (11).
2. Remove screw (13) washer (14) and remove handle (17).
3. Remove screw (15) and washer (16) and disassemble handle assembly (12).
4. Repeat steps 1-3 for interior handle assembly.

## DISASSEMBLY – CONTINUED

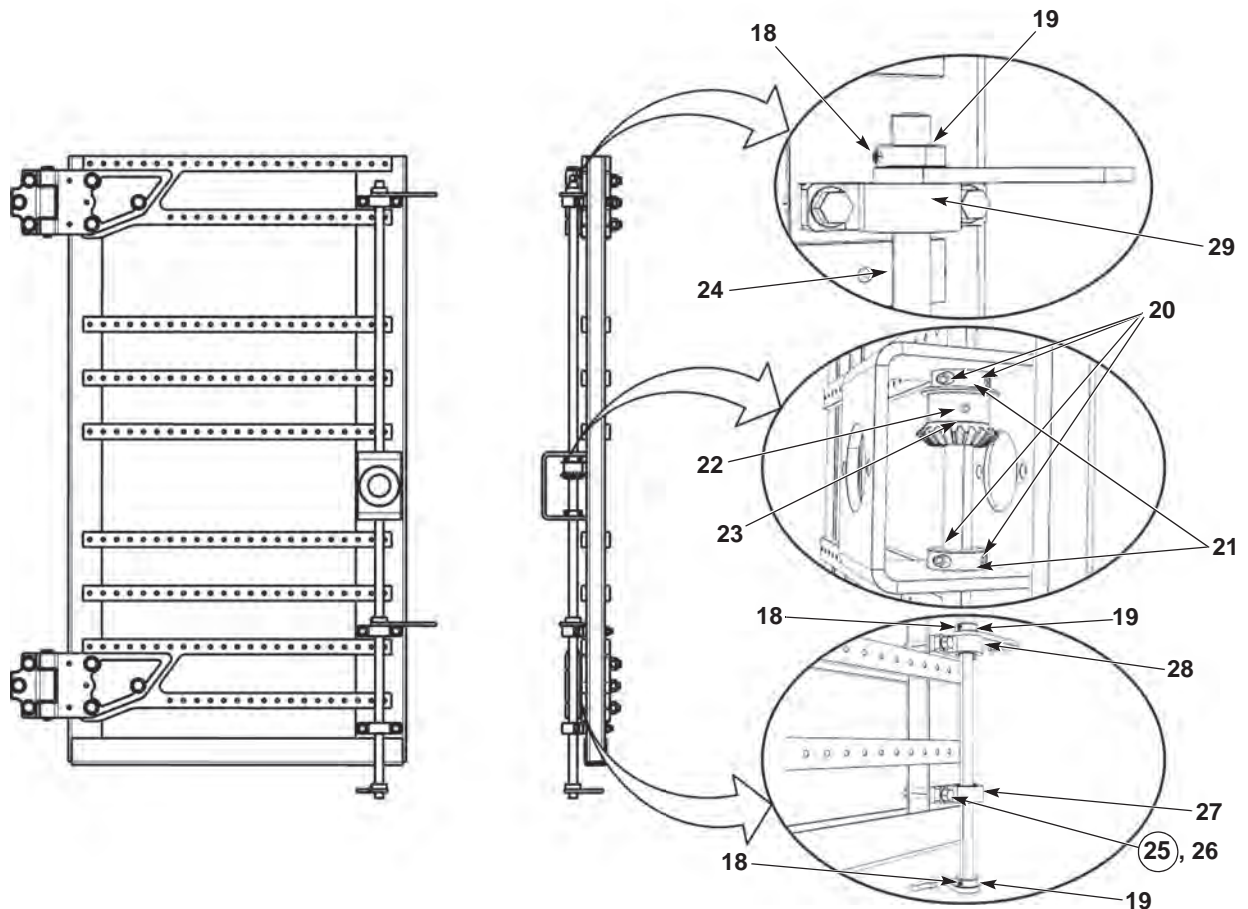
**NOTE**

- Make note of all hardware components and their location prior to removing to ensure proper installation.
- A total of four woodruff keys are used for alignment of three collars (19) and collar gear (23).

5. Loosen three screws (18) from the three collar latches (19).
6. Loosen four screws (20) from the two collars (21).
7. Loosen setscrew (22) in collar gear (23).
8. Remove the guide rod (24).
9. Remove six locknuts (25) six screws (26), and three guide rod brackets (27, 28, and 29). Discard locknuts (25).
10. Remove the rear cargo dyneema panel. (WP 0053).

**END OF TASK**

## DRIVER SIDE REAR CARGO DOOR ASSEMBLY

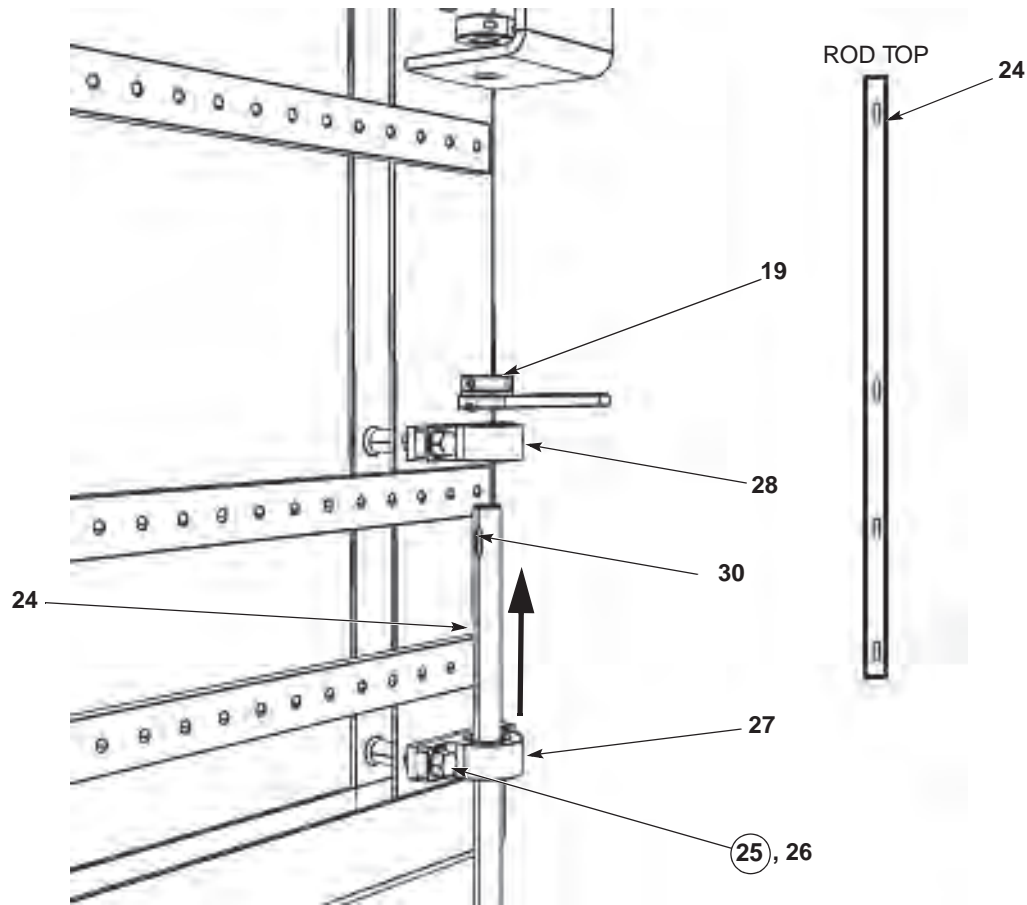
**NOTE**

- When installing handle hardware it is not necessary to tighten until final adjustments are made.
- Prior to final positioning of collar latch (19), ensure woodruff key is placed into noted key slot (30).

1. Install the rear cargo door dyneema panel. (WP 0053).
2. Install three guide rod brackets (27, 28 and 29), and secure with screws (26) and new locknuts (25).
3. Install the guide rod (24) through the bottom guide bracket (27).
4. Install the guide rod (24) through the middle guide bracket (28), and one collar latch (19).

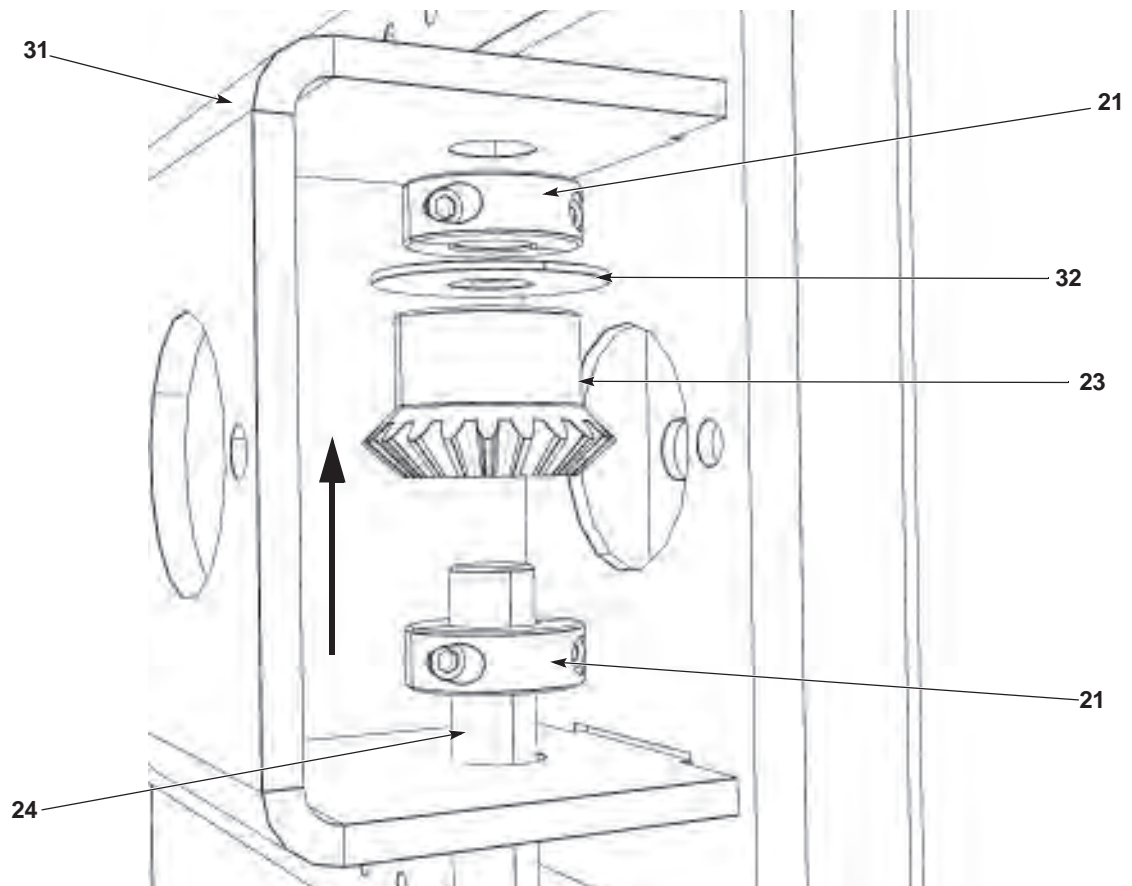

**ASSEMBLY – CONTINUED****NOTE**

- When installing handle hardware it is not necessary to tighten until final adjustments are made.
  - Prior to final positioning of collar gear (23), ensure woodruff key is placed into noted key slot (30).
5. Install the guide rod (24) through the bottom section door handle bracket (31) and install one collar (21), gear (23), washer (32) and second collar (21).

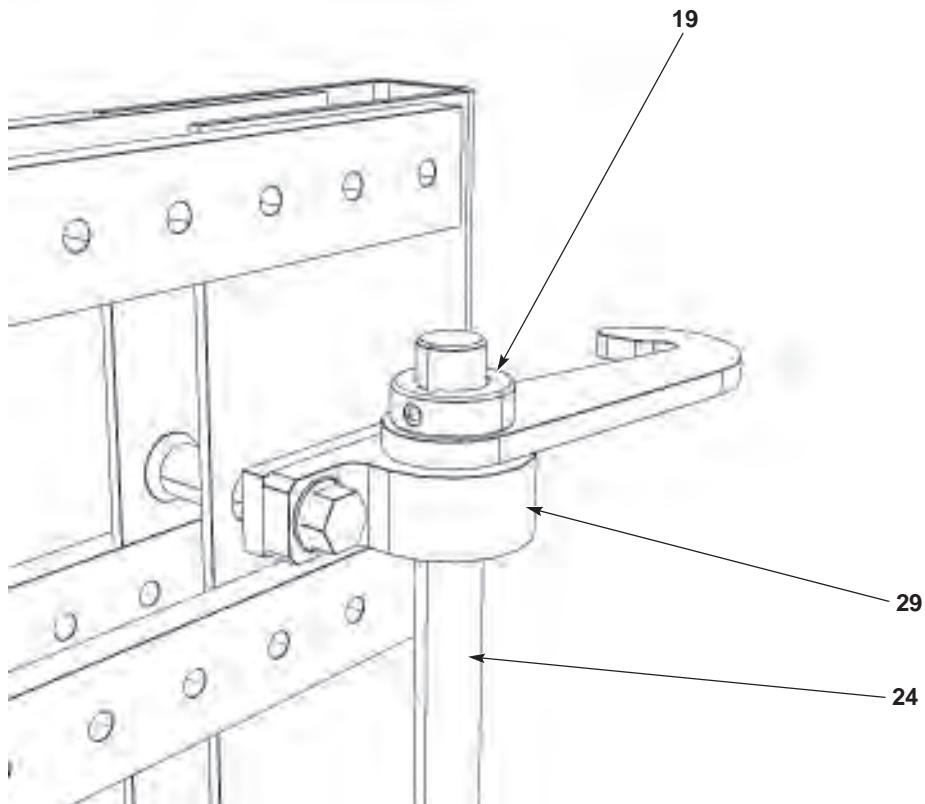
**ASSEMBLY – CONTINUED****NOTE**

- Adjust the guide rod (24) approximately 1/2 in. above collar (19).
  - Prior to final positioning of collar latch (19), ensure woodruff key is properly installed in noted key slot (30).
6. Install guide rod (24) through the top section door handle bracket (29).
  7. Install collar latch (19) at the top of the guide rod (24).

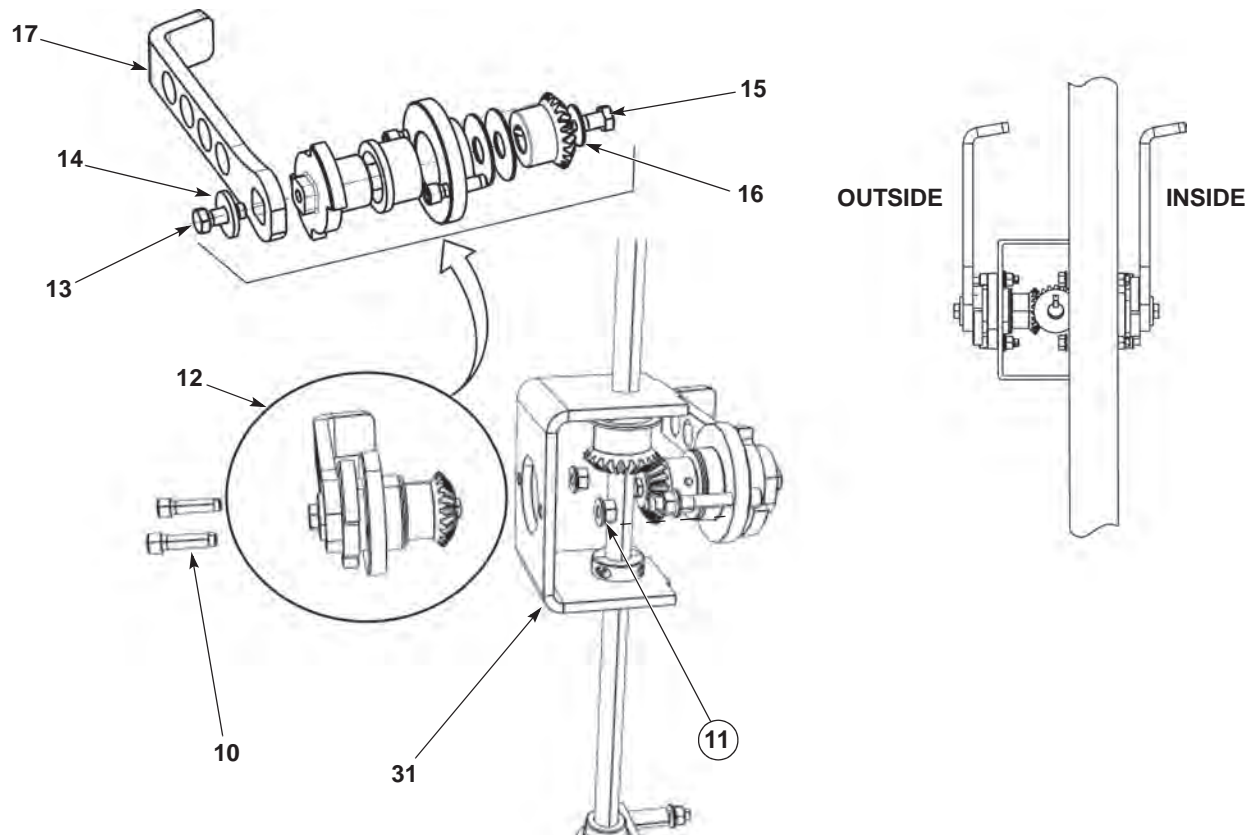
**INSTALLATION – CONTINUED****NOTE**

Procedure to install the rear cargo door handles will be the same for the inside and outside rear cargo door handles.

8. Assemble the handle assembly (12) securing it with washer (16) and screw (15).
9. Install the handle (17) securing it with washer (14) and screw (13).

**NOTE**

Do not tighten hardware until final adjustments are completed.

10. Install the handle assembly (12) into door handle bracket (31), securing it with screws (10) and new locknuts (11).
11. Repeat steps 8-10 for inner handle assembly.

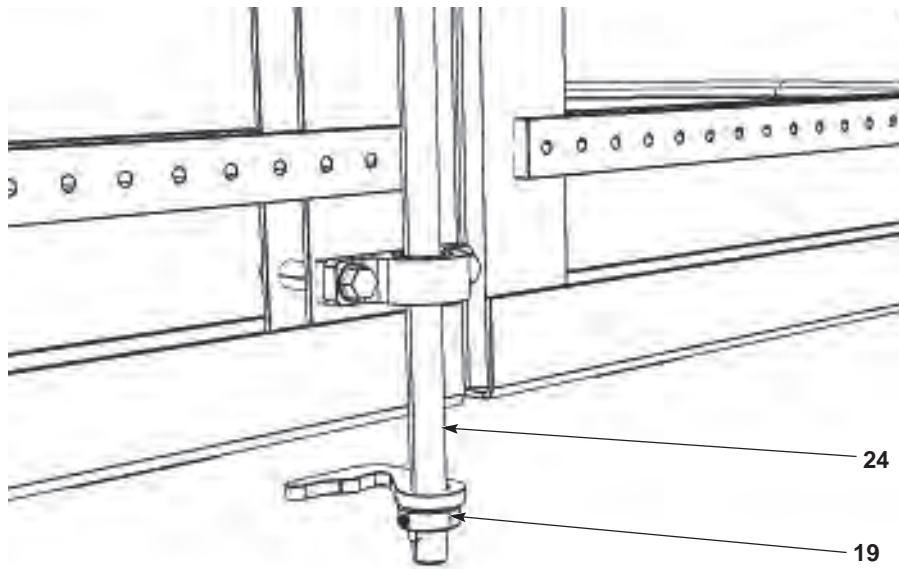
**ASSEMBLY – CONTINUED****NOTE**

Prior to final installation of collar latch (19), install woodruff key in noted slot (30).

12. Install collar latch (19) to the bottom of the guide rod (24) leaving approximately 1/2 in. of the guide rod (22) showing below the collar (19).

**END OF TASK**

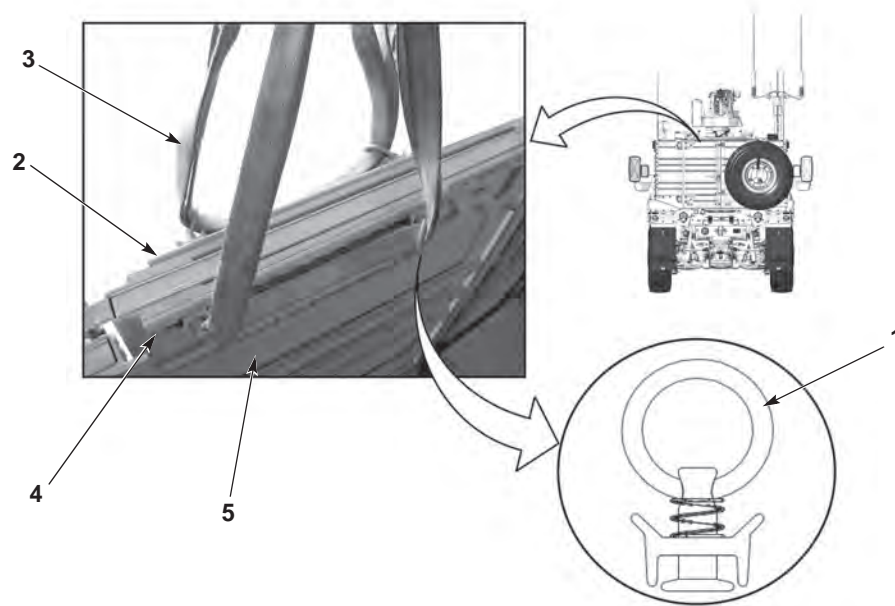
**INSTALLATION****NOTE**

Install tie down tracks as noted prior to removal.

1. Apply loctite threadlocker to screws (4) and install tie down tracks (2) to rear cargo door (5).
2. Install four single stud rings (1) evenly to the top tie down track (2), and attach two 20 ft. straps (3).

## INSTALLATION – CONTINUED

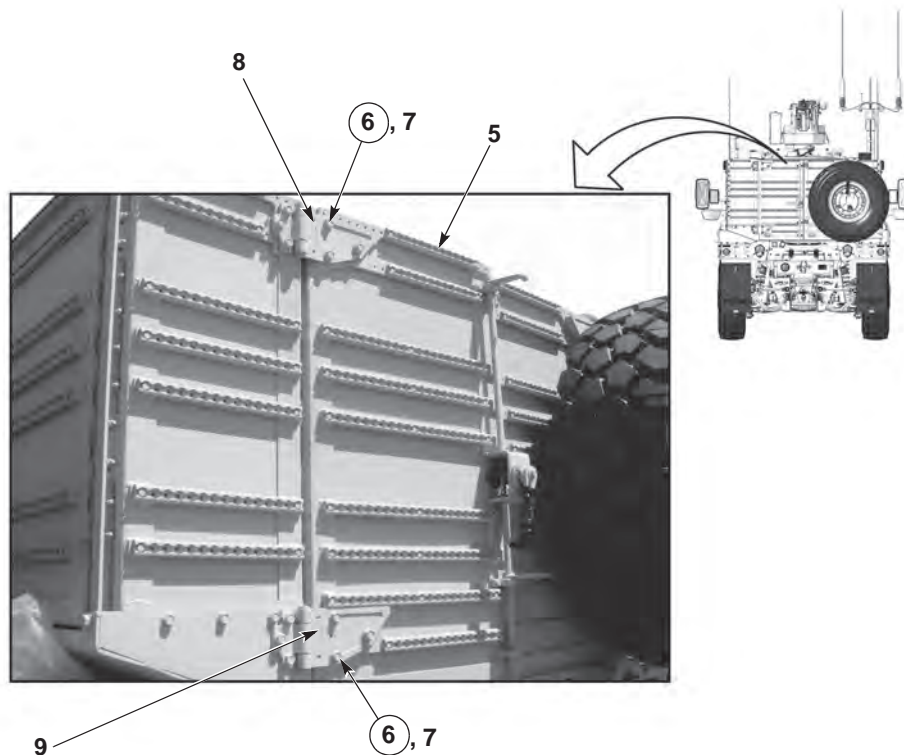
**WARNING**

- Keep hands and fingers away from pinch point areas of litter doors. Hands and fingers could get pinched or crushed. Failure to comply may result in injury to personnel.
- Driver side door assembly weighs 185 lbs (84 kg) and passenger side door assembly weighs 170 lbs (77 kg). Do not attempt to lift or move assemblies without the aid of an assistant and a lifting device. Failure to comply may result in injury or death to personnel.

3. With the aid of an assistant and lifting device, position the cargo door (5) next to the cargo deck.

**NOTE**

Do not tighten hardware until final adjustments and alignments are completed.

4. Align the upper cargo door hinge (8) and lower cargo door hinge (9) to the cargo deck, and install six screws (7) and six new locknuts (6).

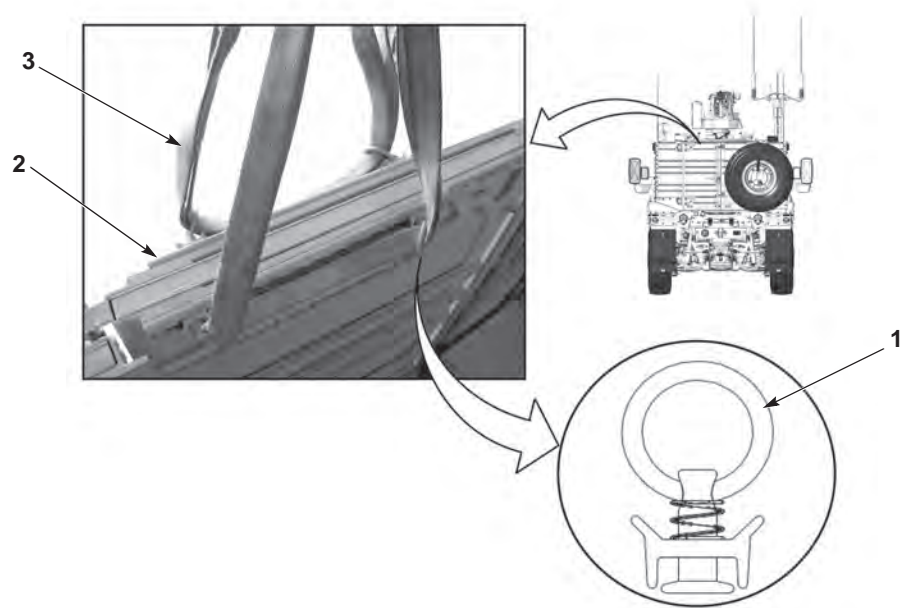

**INSTALLATION – CONTINUED**

5. Remove the 20 ft. straps (3) and four single stud rings (1) from the top tie down track (2).

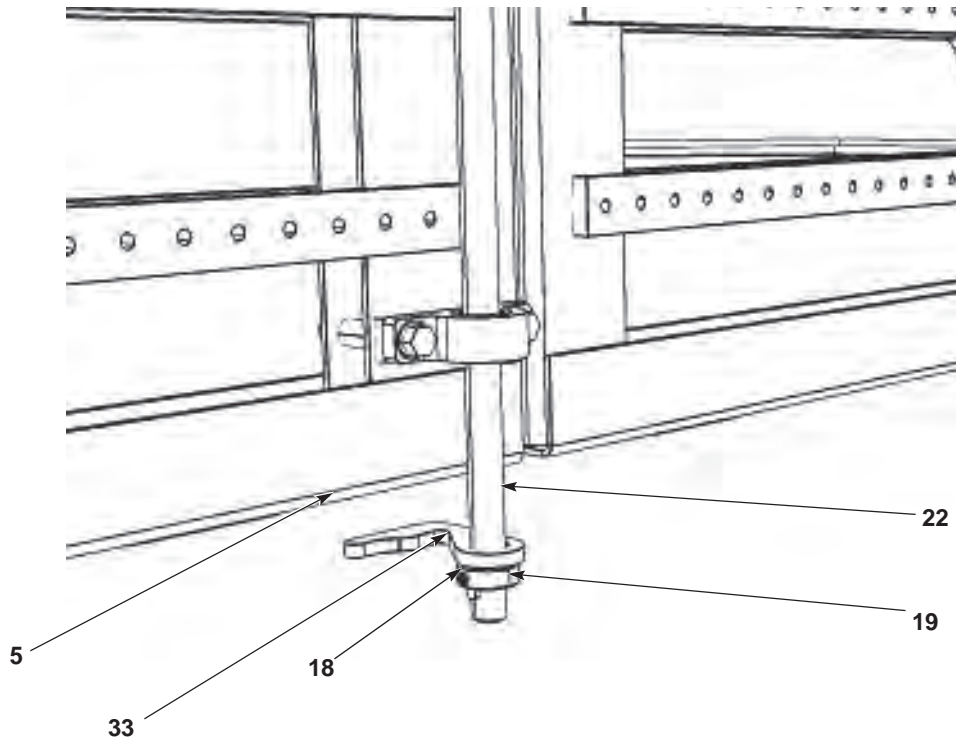
**INSTALLATION – CONTINUED****NOTE**

The vertical adjustment procedure is the same for each latch hook.

6. Make the necessary vertical adjustments by loosening screw (18) and adjusting collar (19) and latch hook (33).
7. When vertical adjustment has been made apply compound sealing, Loctite threadlocker to screw (18).
8. Verify that the driver side cargo door (5) closes securely.
9. Tighten any remaining hardware for hinges and handles.
10. Perform all Follow-On maintenance Tasks.

**END OF TASK**

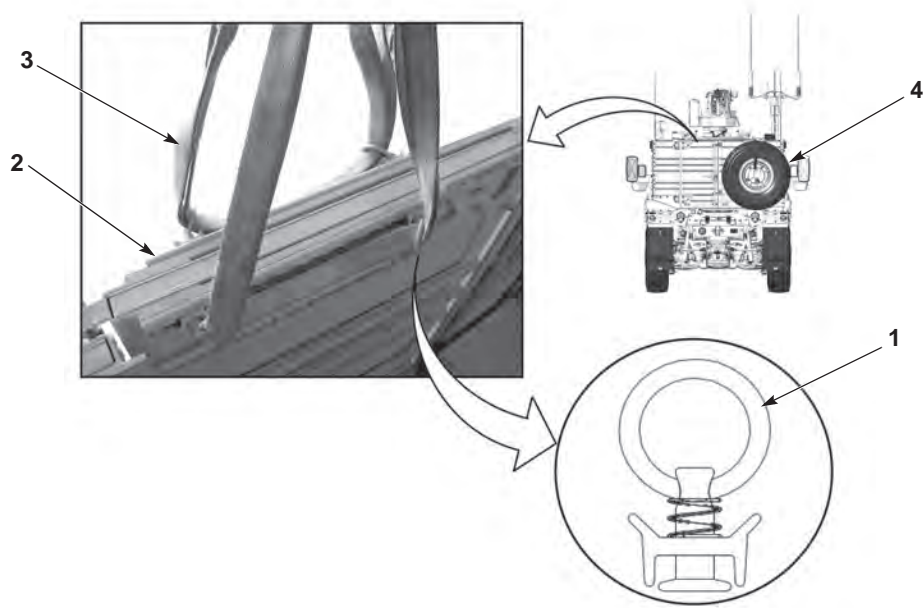
**PASSENGER SIDE REAR CARGO DOOR REMOVAL**

1. Swing the spare tire carrier assembly (4) away for the vehicle to the open position.
2. Install four single stud rings (1) evenly to the top tie down track (2), and attach two 20 ft. straps (3).

## REMOVAL – CONTINUED

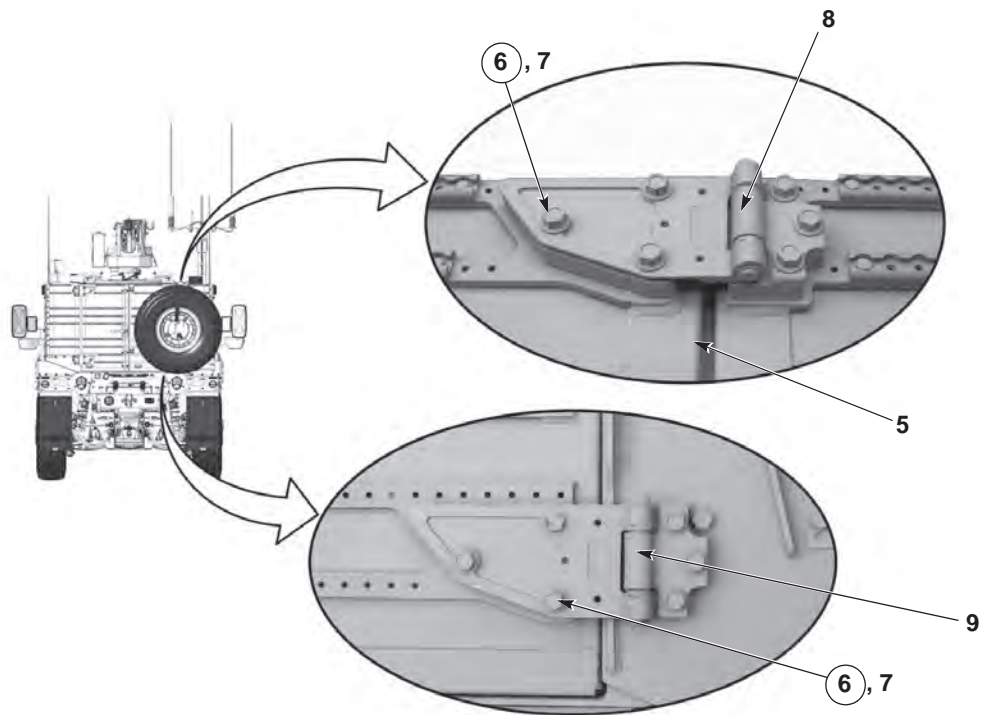
**WARNING**

- Keep hands and fingers away from pinch point areas of litter doors. Hands and fingers could get pinched or crushed. Failure to comply may result in injury to personnel.
- Driver side door assembly weighs 185 lbs (84 kg) and passenger side door assembly weighs 170 lbs (77 kg). Do not attempt to lift or move assemblies without the aid of an assistant and a lifting device. Failure to comply may result in injury or death to personnel.

3. With the aid of an assistant and lifting device, support the cargo door (5).
4. Remove six locknuts (6) and six screws (7) from the upper cargo door hinge (8) and lower cargo door hinge (9). Discard locknuts (6).
5. With the aid of an assistant and lifting device, remove the cargo door (5).

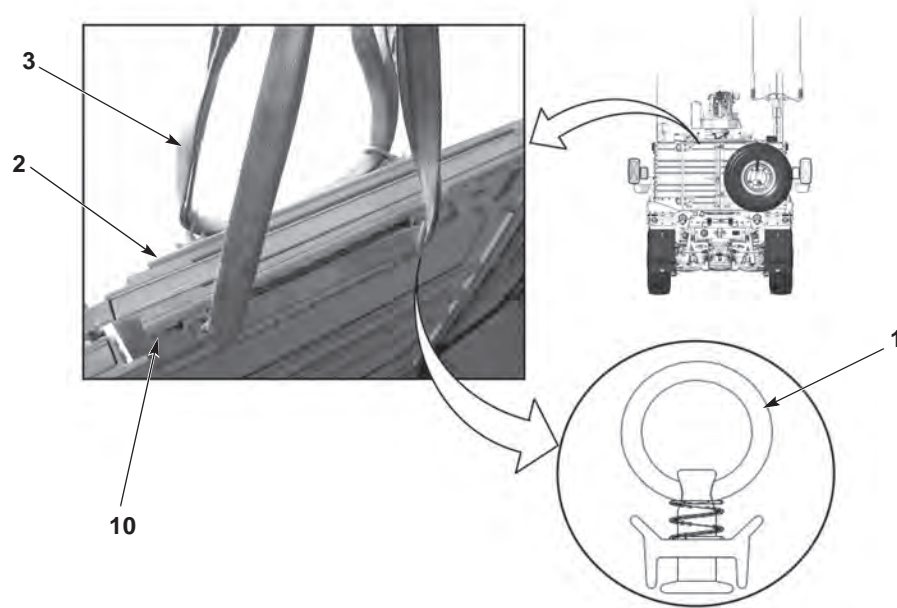
**REMOVAL – CONTINUED****NOTE**

For installation purposes, note the location, length, and configuration of each tie down track strip prior to removal

6. Remove the 20 ft. straps (3) and four single stud rings (1) from the top tie down track (2).
7. Remove screws (10) and tie down tracks (2) from rear cargo door.

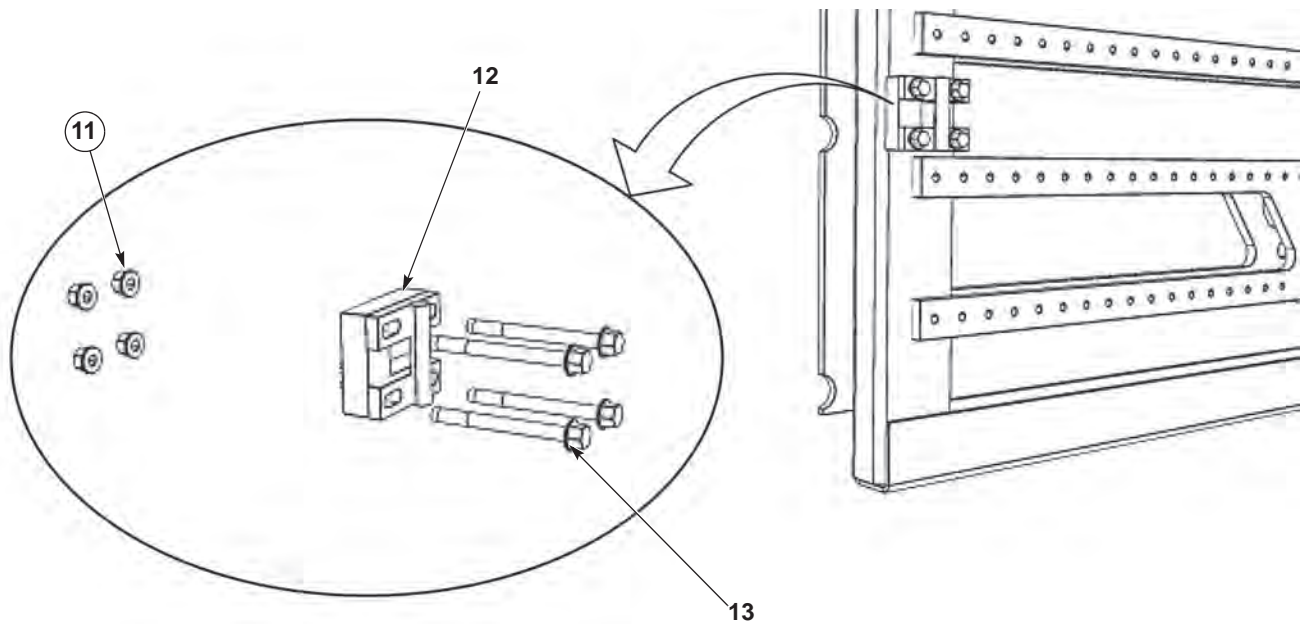
**REMOVAL – CONTINUED****NOTE**

Procedures for both latch mechanisms will be the same.

8. Remove four locknuts (11) screws (13), and remove latch mechanism (12). Discard locknuts (11).
9. Remove rear cargo door dyneema panel. (WP 0053).

**END OF TASK**



## PASSENGER SIDE REAR CARGO DOOR INSTALLATION

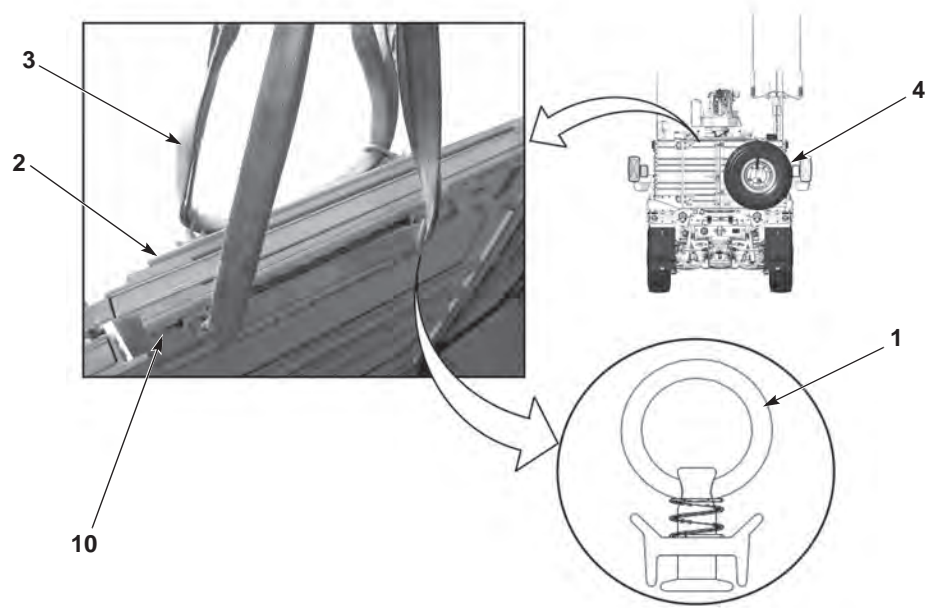

1. Ensure that the spare tire carrier assembly (4) is in the open position.
2. Install the rear cargo door dyneema panel. (WP 0053).

### NOTE

Install tie down tracks as noted prior to removal.

3. Apply loctite threadlocker to screws (10) and install tie down tracks (2) to rear cargo door (5).
4. Install four single stud rings (1) evenly to the top tie down track (2), and attach two 20 ft. straps (3).

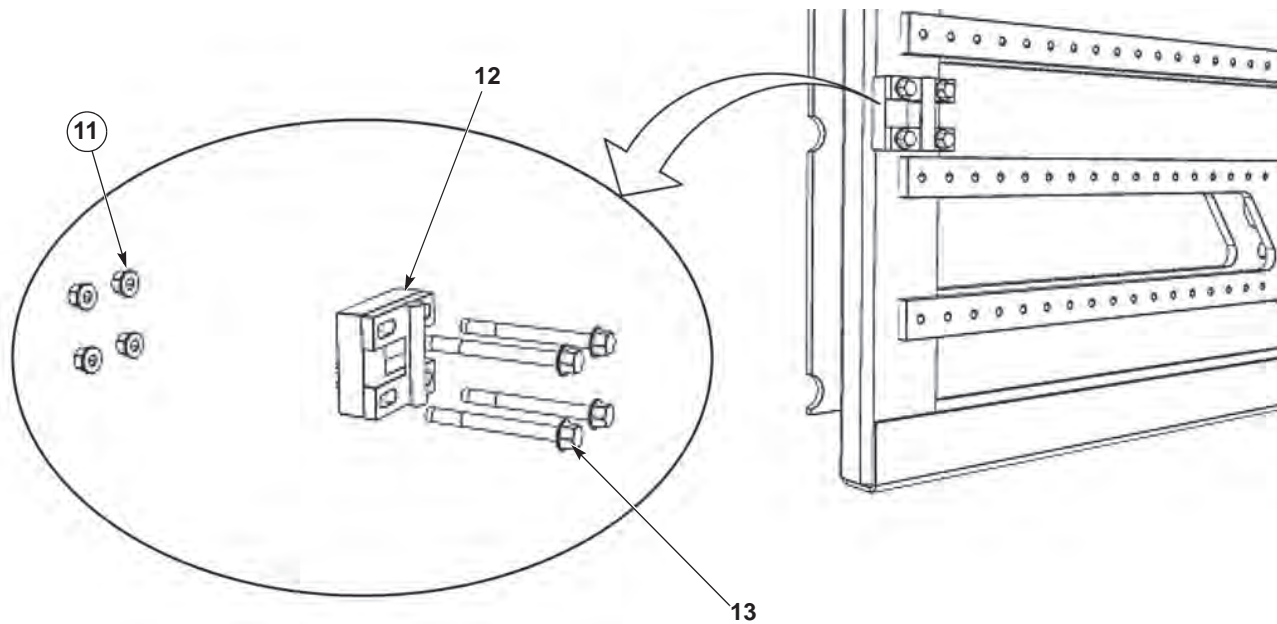
**INSTALLATION – CONTINUED****NOTE**

When installing latch mechanism do not tighten hardware until final adjustments are made.

5. Install latch mechanism (12) and secure with screws (13) and four new locknuts (11).

## INSTALLATION – CONTINUED

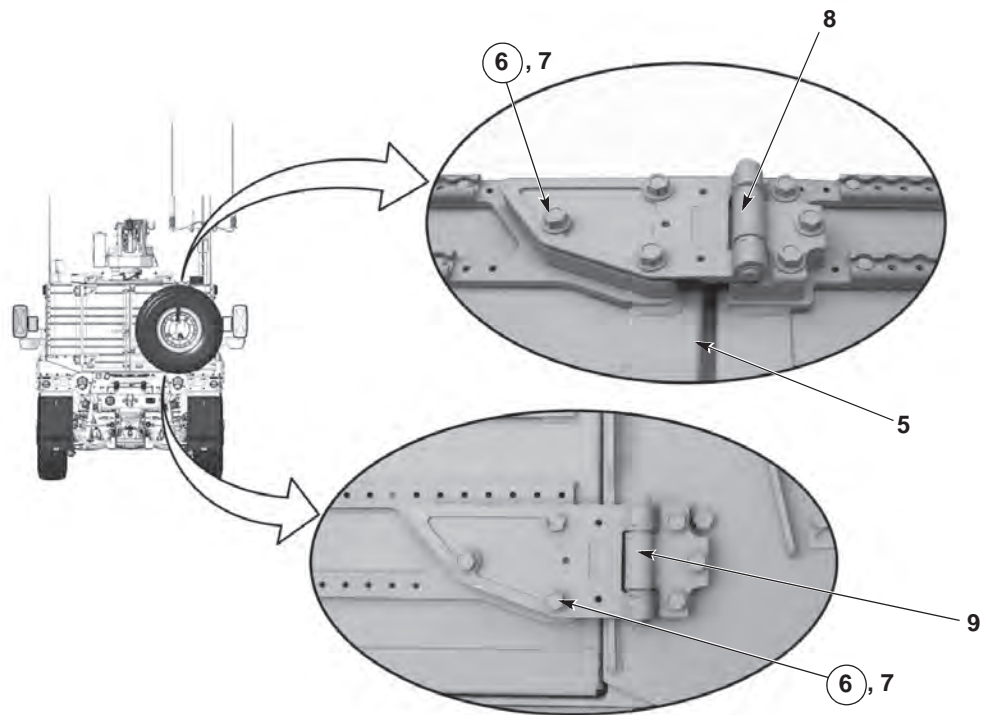
**WARNING**

- Keep hands and fingers away from pinch point areas of litter doors. Hands and fingers could get pinched or crushed. Failure to comply may result in injury to personnel.
- Driver side door assembly weighs 185 lbs (84 kg) and passenger side door assembly weighs 170 lbs (77 kg). Do not attempt to lift or move assemblies without the aid of an assistant and a lifting device. Failure to comply may result in injury or death to personnel.

6. With the aid of an assistant and lifting device, position the cargo door (5) next to the cargo deck.

**NOTE**

Do not tighten hardware until final adjustments are completed.

7. Align the upper cargo door hinge (8) and lower cargo door hinge (9) to the cargo deck, and install six screws (7) and six new locknuts (6).

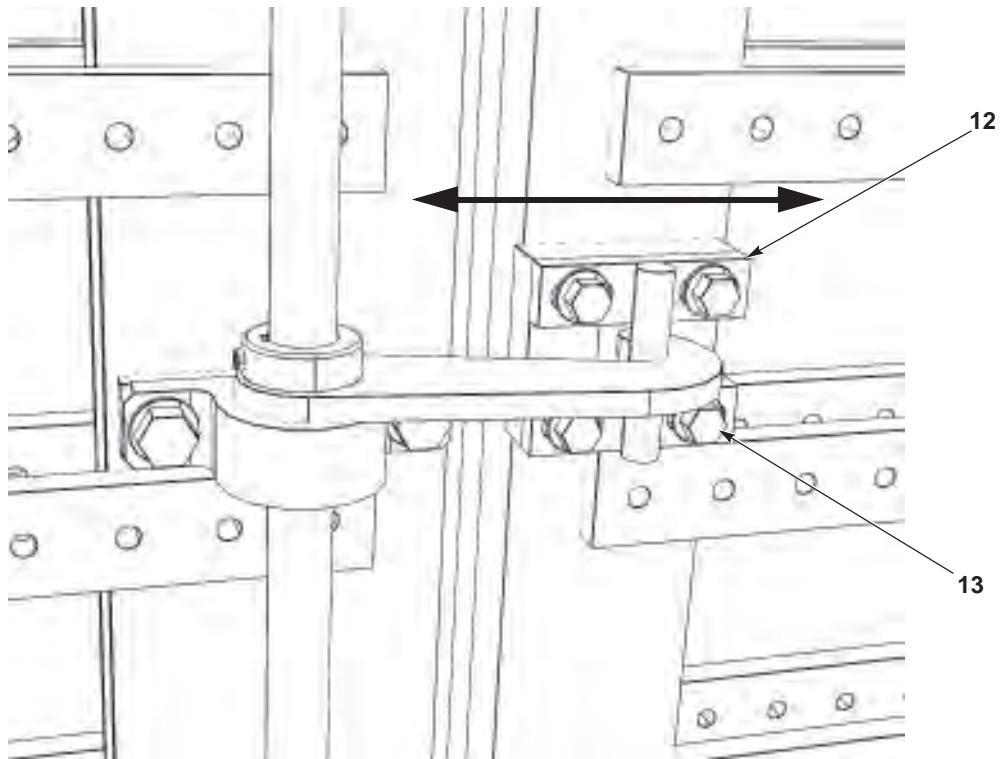
**INSTALLATION – CONTINUED****NOTE**

The adjustment procedure is the same for each latch mechanism.

8. Adjust the latch mechanism (12) passenger side cargo door by loosening four screws (13), and sliding the latch mechanism (12) left or right.

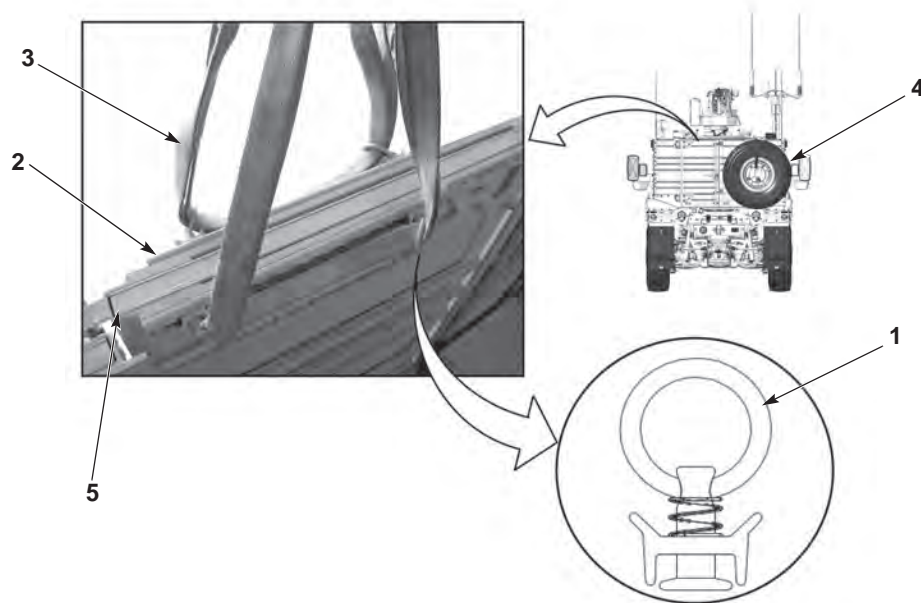
**INSTALLATION – CONTINUED**

9. Remove the 20 ft. straps (3) and four single stud rings (1) from the top tie down track (2).

**NOTE**

When performing alignment of door, swing spare tire carrier into the stowed position. Doors cannot be properly aligned with spare tire carrier in unstowed position.

10. Verify that the passenger side cargo door (5) closes securely.
11. Swing the spare tire carrier assembly (4) back into the closed position.
12. Tighten all remaining hardware in hinges and latch mechanisms.
13. Perform all Follow-On Maintenance Tasks.

**END OF TASK**

**END OF WORK PACKAGE**





---

**CARGO DECK SIDE WALL REPLACEMENT (M1245)**

---

**Preconditions**

Park Vehicle  
 Engine OFF  
 Wheels Chocked

**Materials/Parts**

Lockwasher (4) (Item 4)  
 Locknut (6) (Item 6)  
 Lockwasher (5) (Item 9)

**Tools and Special Tools**

Lifting Device  
 Strap, 20 ft. (2)  
 Single Stud Ring (4)  
 Tool Kit, General Mechanic's: Automotive

**Tools and Special Tools (continued)**

Loctite threadlocker

**Personnel Required**

Two

**References**

Side Wall Dyneema Panel Replacement  
 Replacement (WP 0055)

**Follow-On Maintenance**

Remove and Stow Wheel Chocks

---

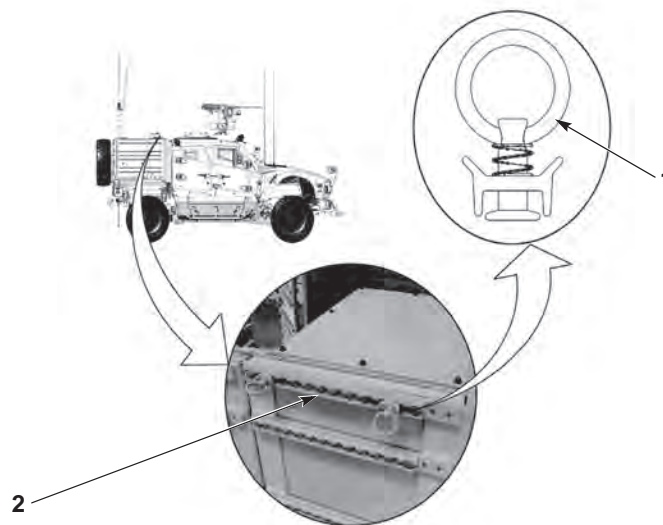
**CARGO DECK SIDE WALL REMOVAL****WARNING**

Panel assemblies for cargo body weigh 90 lbs (41 kg). Do not attempt to lift or move assemblies without the aid of an assistant and a lifting device. Failure to comply may result in injury or death to personnel.

**NOTE**

Driver side and passenger side cargo deck side wall are removed the same way.

1. Install two single stud rings (1) evenly to the top tie down track (2), and attach a 20 ft. strap.

---

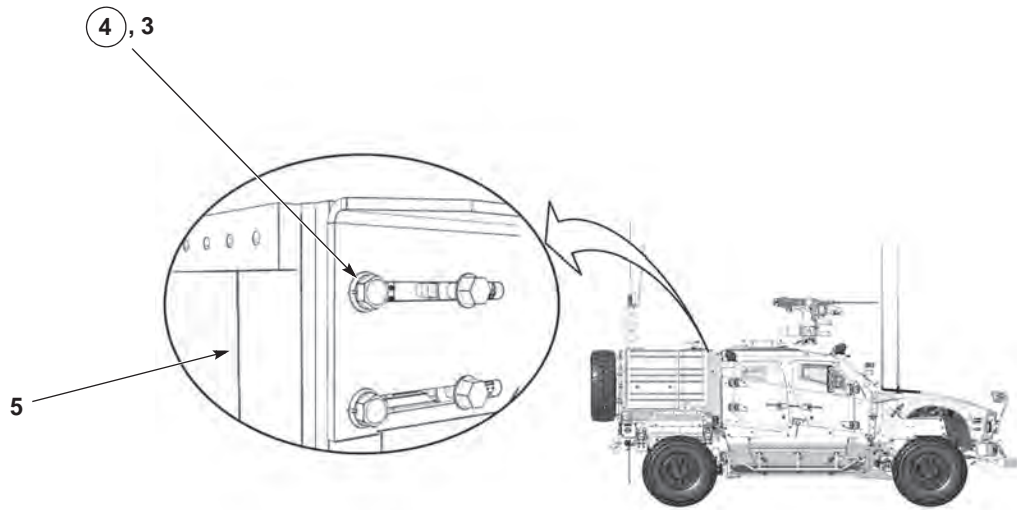
**REMOVAL- CONTINUED**

2. Remove two screws (3) and two lockwashers (4) from the side wall (5). Discard lockwashers (4).

## REMOVAL- CONTINUED

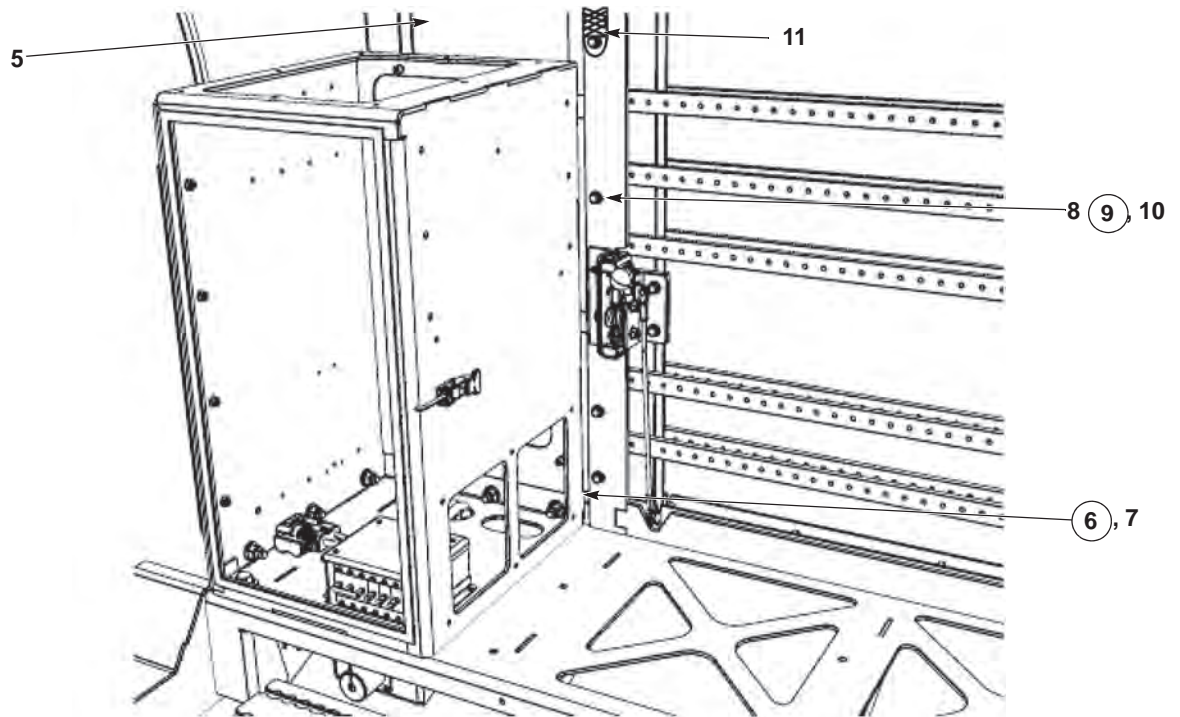
**NOTE**

- For passenger side only, perform step 4.
  - Passenger side shown.
3. With the aid of an assistant and lifting device, support cargo deck side wall (5).
  4. Remove three locknuts (6) and three screws (7) from the side wall (5). Discard locknuts (6).
  5. Remove five screws (8), five lockwashers (9), five washers (10), and ground strap (11). Discard lockwashers (8).
  6. With the aid of an assistant and lifting device, remove the cargo deck side wall (5).

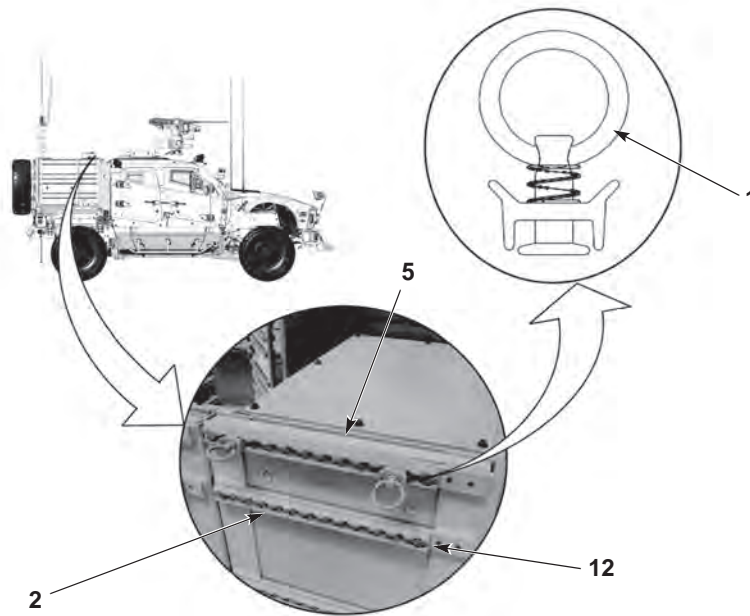
**REMOVAL- CONTINUED****NOTE**

For installation purposes, note the location, length and configuration of each tie down track strip prior to removal.

7. Remove 20 ft. strap, and two single stud rings (1) from the top tie down track (2).
8. Remove screws (12) and tie down track (2) from the cargo deck side wall (5).
9. Remove cargo deck side wall dyneema panel. (WP 0055).

**END OF TASK**

**INSTALLATION**

1. Install cargo deck side wall dyneema panel. (WP 0055).

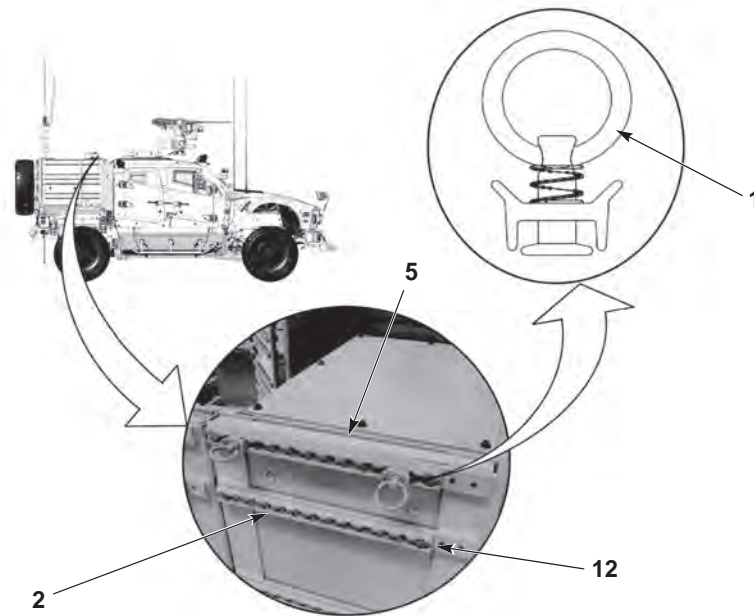
**WARNING**

**Panel assemblies for cargo body weigh 90 lbs (41 kg). Do not attempt to lift or move assemblies without the aid of an assistant and a lifting device. Failure to comply may result in injury or death to personnel.**

**NOTE**

- Install tie down tracks as noted prior to removal.
  - Driver side and passenger side cargo deck side wall are installed the same way.
2. Apply Loctite threadlocker to screws (12) and install tie down tracks (2) to the cargo deck side wall (5).
  3. Install two single stud rings (1) evenly to the top tie down track (2), and attach a 20 ft. strap.
  4. With the aid of an assistant and lifting device, lift and support the cargo deck side wall (5).

## INSTALLATION – CONTINUED

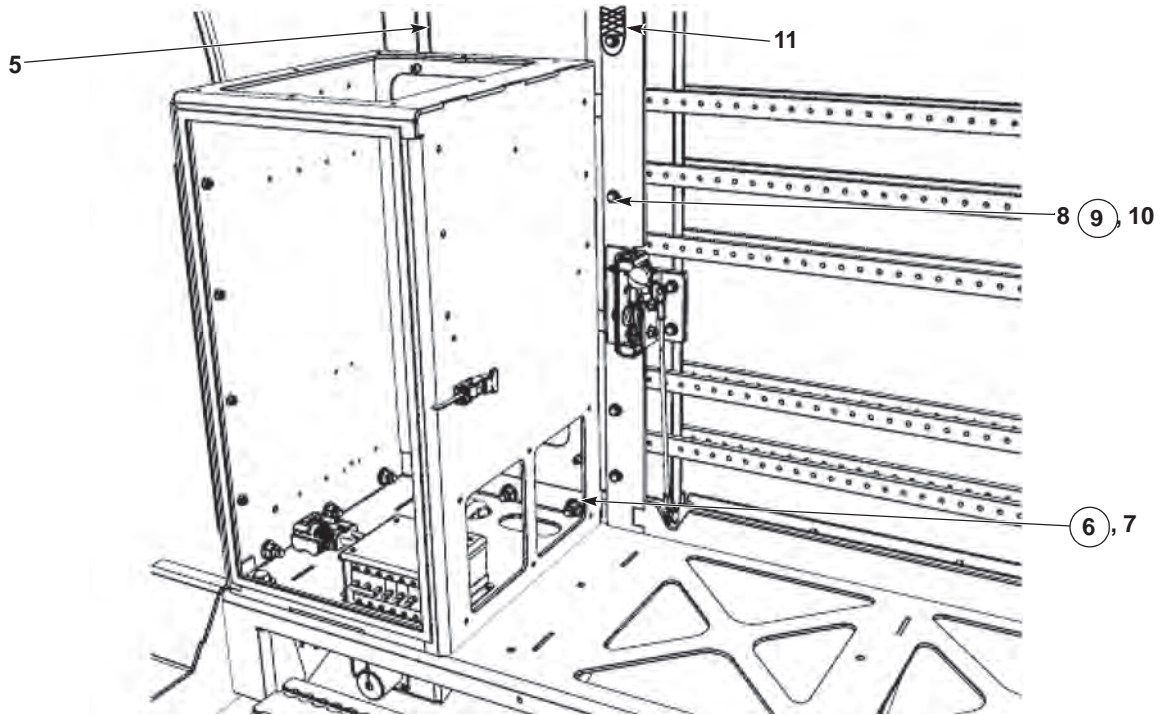
**NOTE**

- For passenger side only, perform step 5.
- Passenger side shown.
- When performing steps 5 and 6, do not tighten hardware until final adjustments are made.

5. Install three screws (7) and three new locknuts (6) to the cargo deck side wall (5).
6. Install ground strap (11), five washers (10), five new lockwashers (9), and five screws (8).

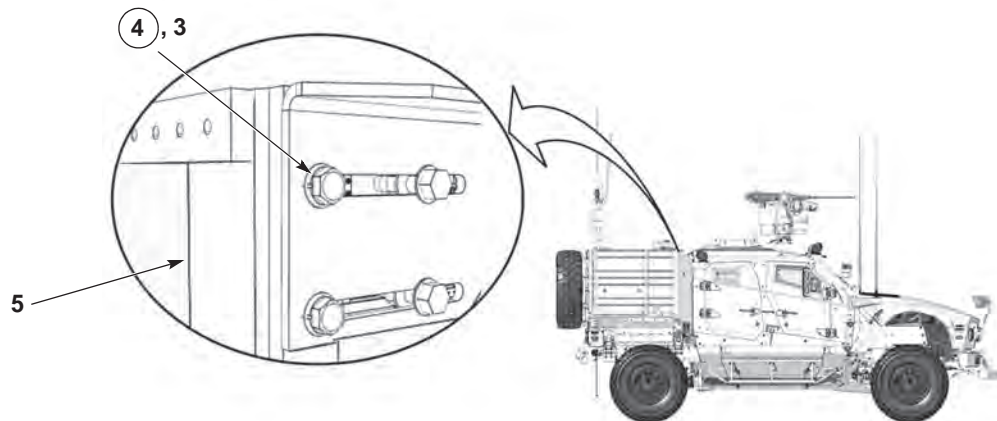

**INSTALLATION – CONTINUED**

7. Install two new lockwashers (4) and two screws (3) securing the upper portion of the cargo deck side wall (5).

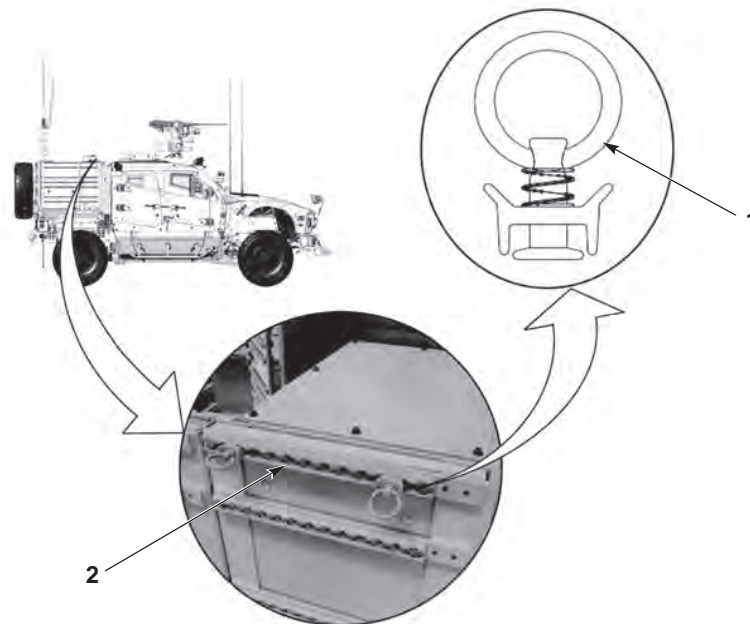

8. Remove 20 ft. strap, and two single stud rings (1) from the top tie down track (2).  
 9. Perform all Follow-On maintenance Tasks.

**END OF TASK**

**END OF WORK PACKAGE**



---

**FRONT BUMPER REPLACEMENT (STANDARD SPARK)**

---

**Preconditions**

Park vehicle  
 Engine OFF  
 Wheels chocked  
 Air system drained  
 Hood removed (WP 0158)

**Tools and Special Tools**

Lifting Device  
 Tool Kit, General Mechanic's: Automotive

**Materials/Parts**

Locknut (4) (Item 1)  
 Locknut (2) (Item 7)  
 Locknut (3) (Item 11)  
 Locknut (3) (Item 16)  
 Locknut (4) (Item 19)

**Materials/Parts (continued)**

Locknut (4) (Item 22)  
 Lockwasher (4) (Item 30)  
 Locknut (2) (Item 34)  
 Lockwasher (2) (Item 39)  
 Locknut (3) (Item 42)  
 Locknut (3) (Item 47)  
 Tags, Identification  
 Ties, Cable

**Personnel Required**

Two

**Follow-On Maintenance**

Install hood (WP 0158)  
 Remove and stow wheel chocks

---

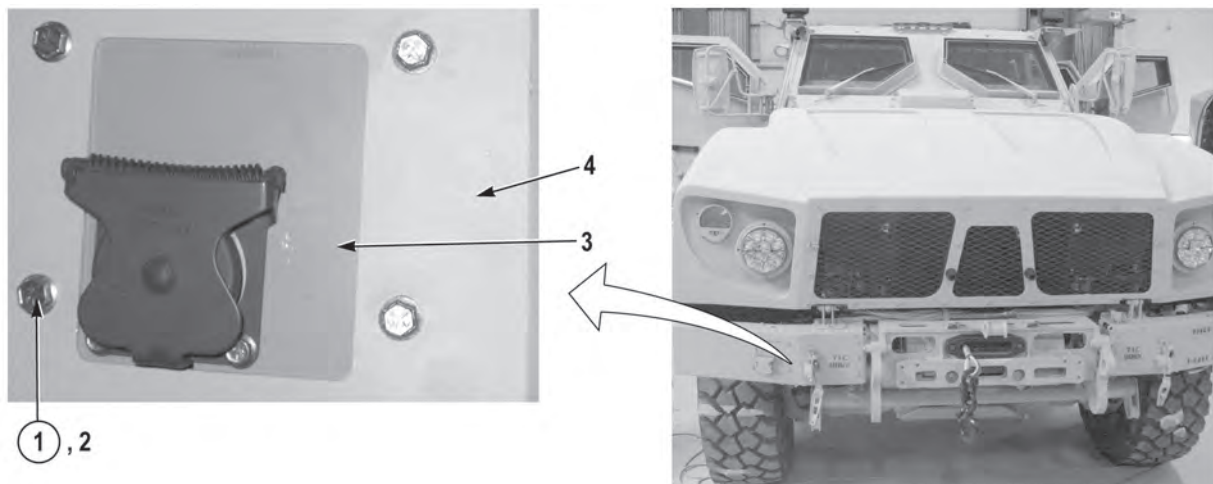
**REMOVAL****NOTE**

Perform Steps (1) through (7) to remove passenger side bumper.

1. Remove four locknuts (1), screws (2), and intervehicular connector assembly (3) from passenger side bumper (4). Discard locknuts (1).

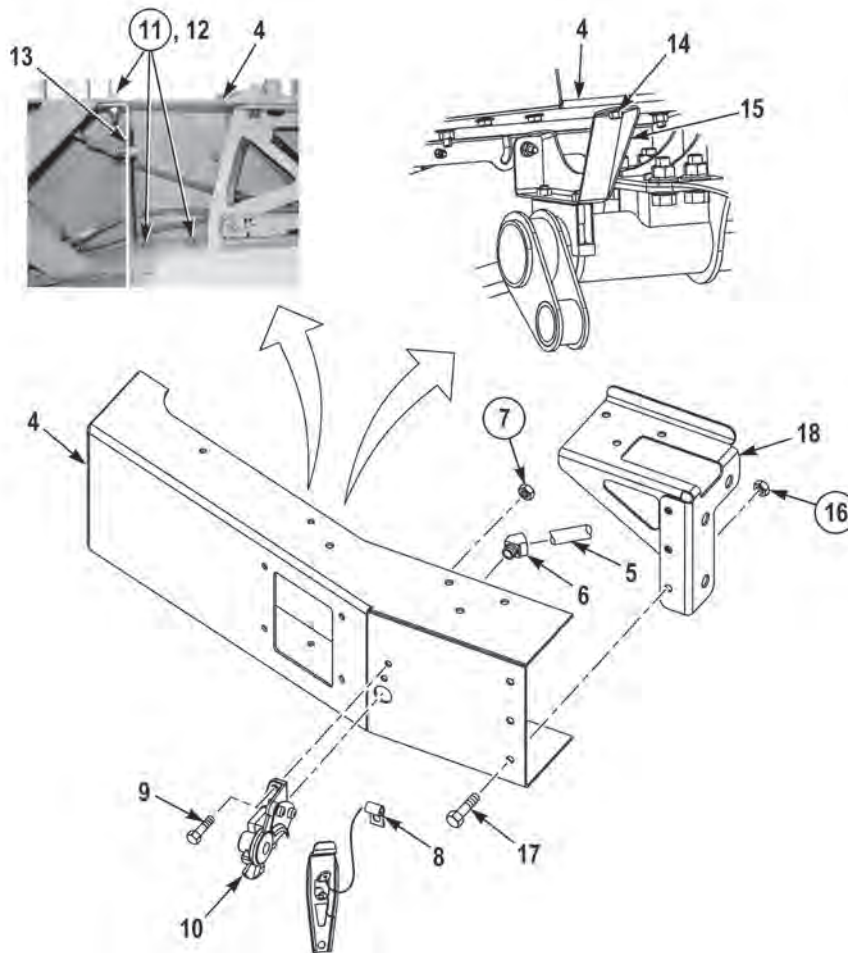

### NOTE

Tag and mark air lines prior to removal to ensure proper installation.

2. Remove air line (5) from fitting (6).
3. Remove two locknuts (7), cushion clip (8), two screws (9), and gladhand assembly (10) from passenger side bumper (4). Discard locknuts (7).
4. Remove three locknuts (11) and screws (12) from passenger side bumper (4) and bracket (13). Discard locknuts (11).
5. Remove screw (14) from bracket (15) and passenger side bumper (4).
6. Remove three locknuts (16), screws (17), and passenger side bumper (4) from bracket (18). Discard locknuts (16).

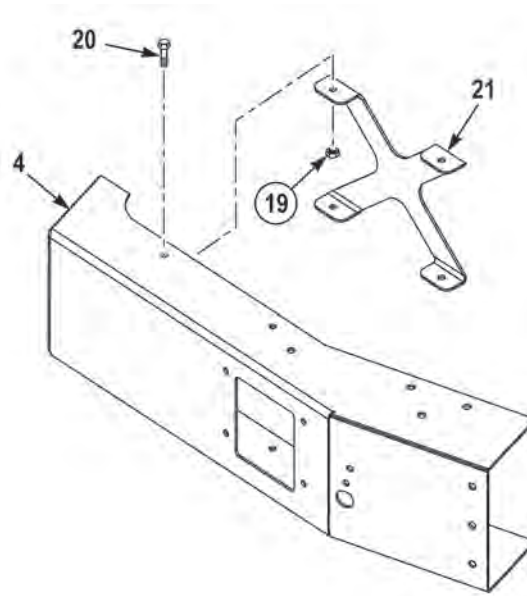

7. Remove four locknuts (19), screws (20), and bracket (21) from passenger side bumper (4). Discard locknuts (19).

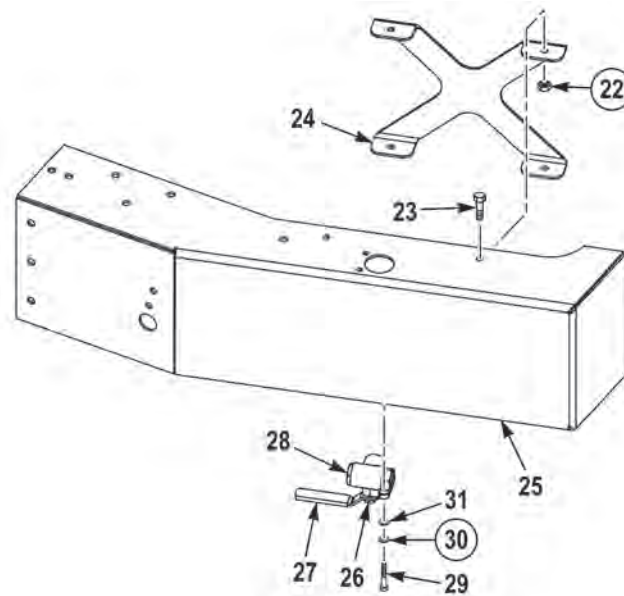

### NOTE

Perform Steps (8) through (16) to remove driver side bumper.

8. Remove four locknuts (22), screws (23), and bracket (24) from driver side bumper (25). Discard locknuts (22).
9. Remove two nuts (26) and handles (27) from two valves (28).
10. Remove four screws (29), lockwashers (30), washers (31), and two valves (28) from driver side bumper (25). Discard lockwashers (30).

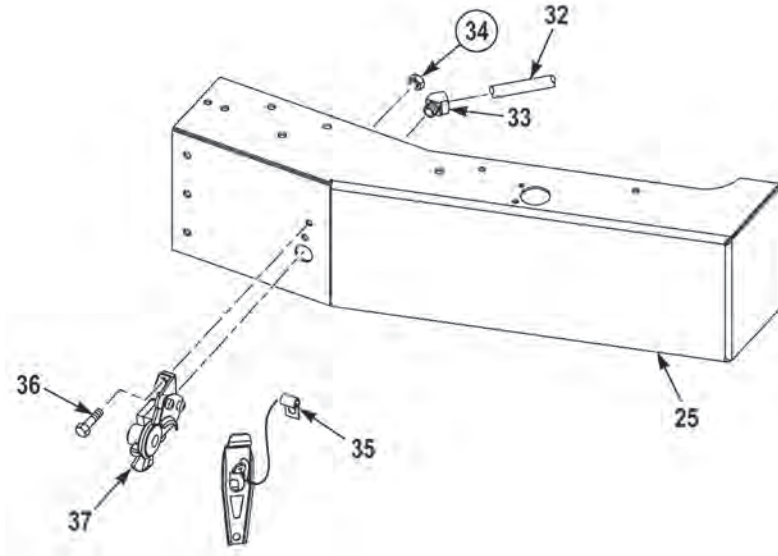

11. Remove air line (32) from fitting (33).
12. Remove two locknuts (34), cushion clip (35), two screws (36), and gladhand assembly (37) from driver side bumper (25). Discard locknuts (34).

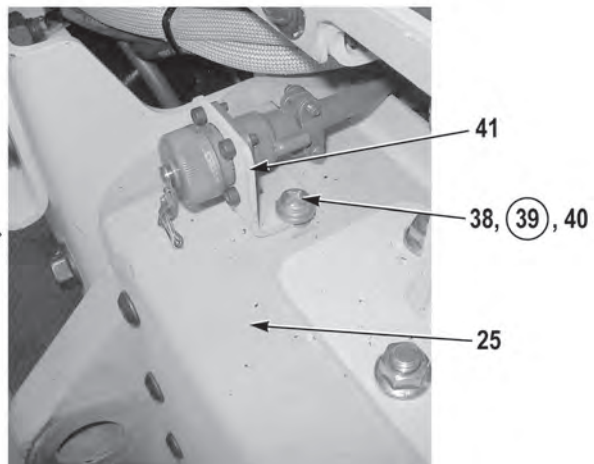

13. Remove two screws (38), lockwashers (39), washers (40), and winch remote control connector assembly (41) from driver side bumper (25). Discard lockwashers (39).



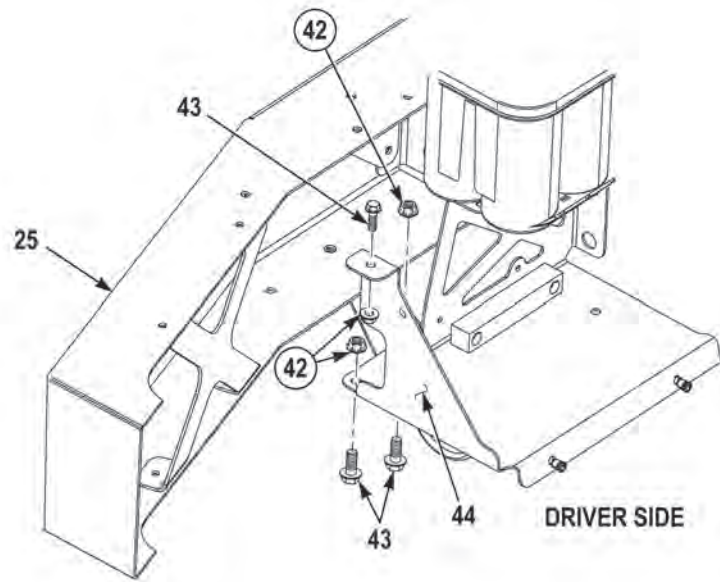

14. Remove three locknuts (42) and screws (43) from driver side bumper (25) and bracket (44). Discard locknuts (42).

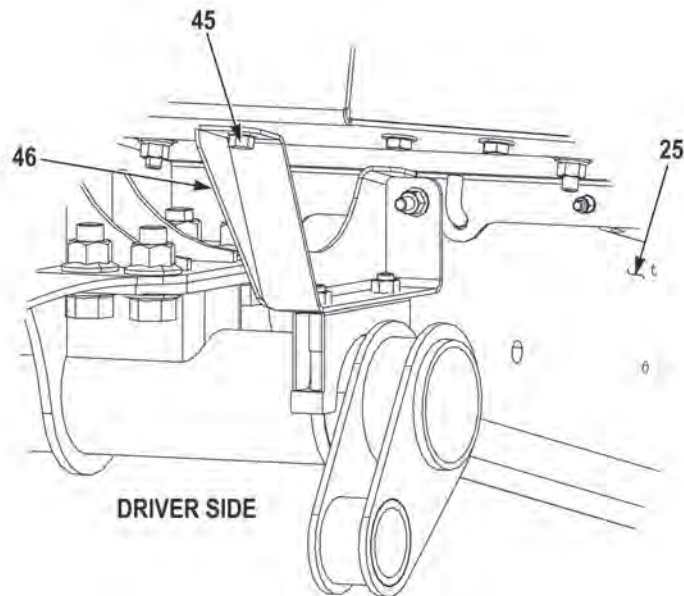

15. Remove screw (45) from bracket (46) and driver side bumper (25).

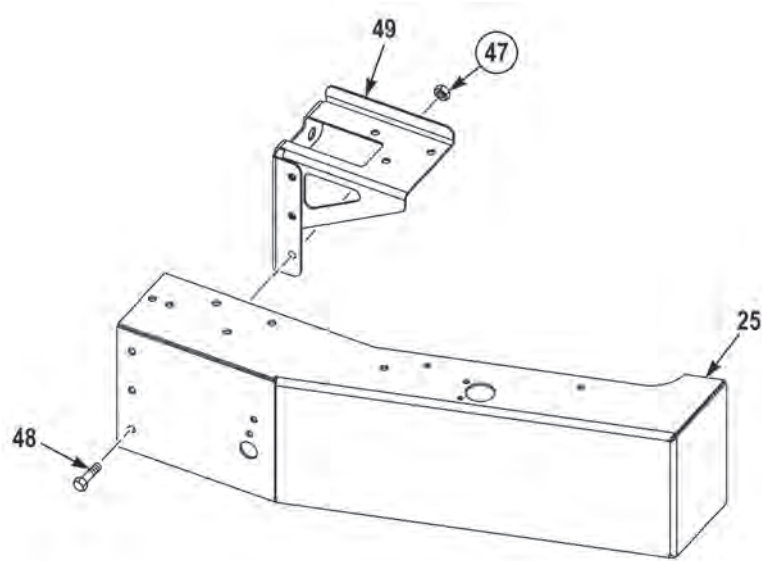

16. Remove three locknuts (47), screws (48), and driver side bumper (25) from bracket (49). Discard locknuts (47).

#### END OF TASK

#### INSTALLATION

#### NOTE

Perform Steps (1) through (9) to install driver side bumper.

1. Install driver side bumper (25) on bracket (49) with three screws (48) and new locknuts (47).

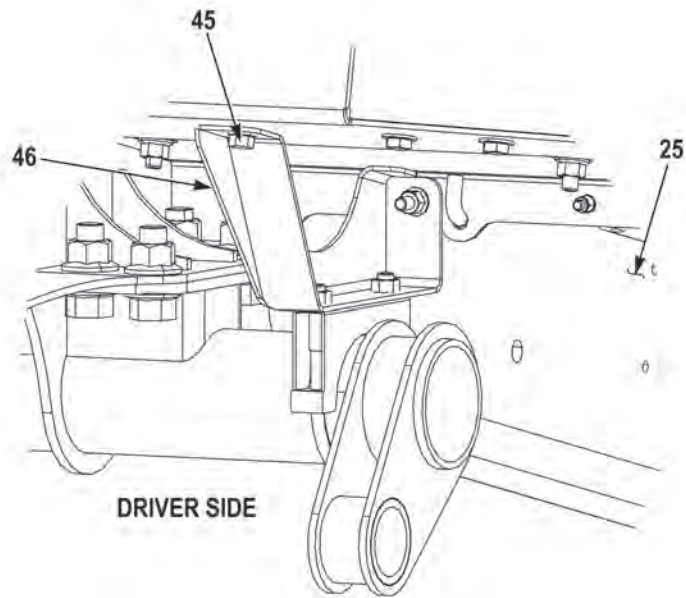

2. Install screw (45) on bracket (46) and driver side bumper (25).

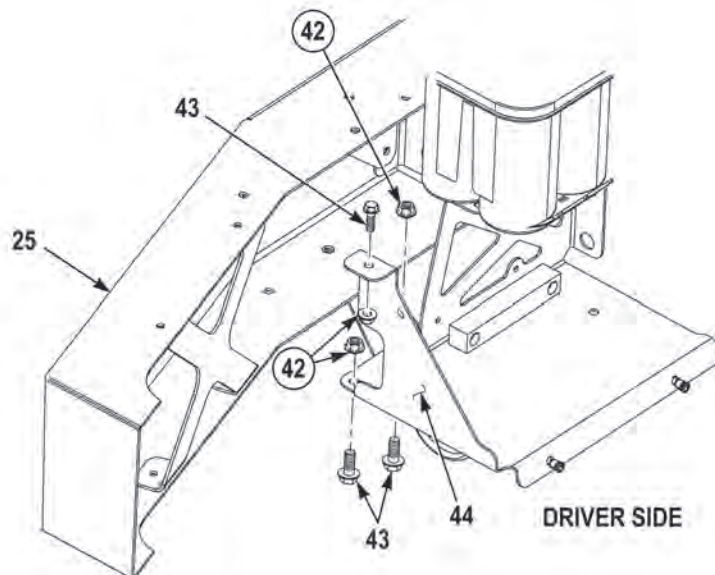

3. Install three screws (43) and new locknuts (42) on driver side bumper (25) and bracket (44).

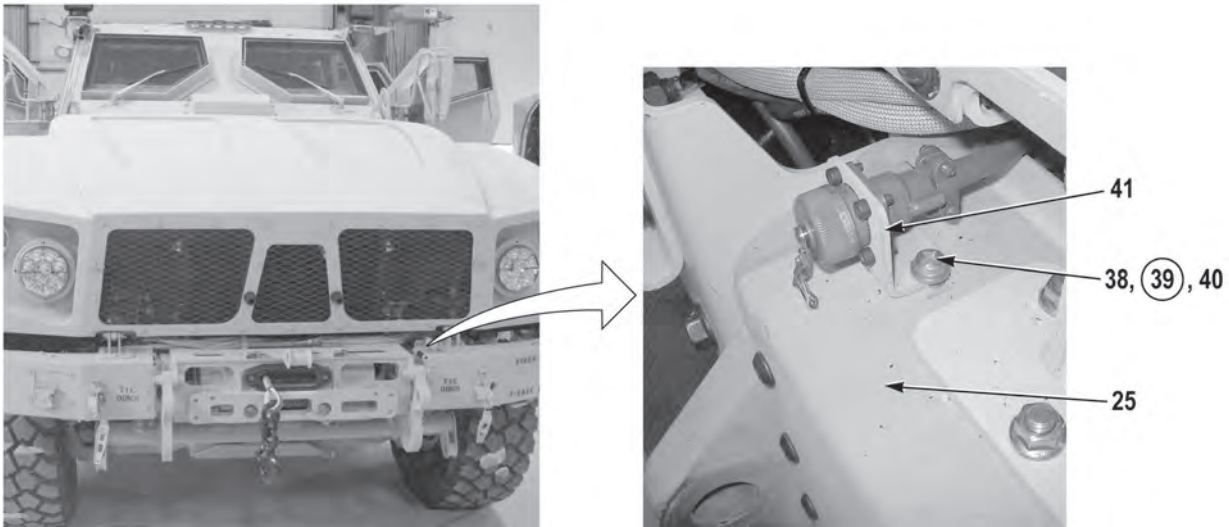

4. Install winch remote control connector assembly (41) on driver side bumper (25) with two washers (40), new lockwashers (39), and screws (38).

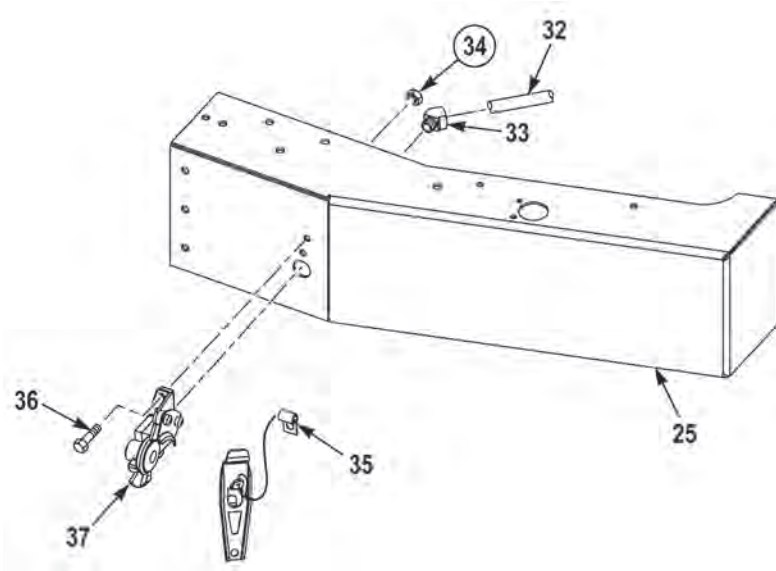

**NOTE**

Install cable ties as required.

5. Install gladhand assembly (37) and cushion clip (35) on driver side bumper (25) with two screws (36) and new locknuts (34).
6. Install air line (32) on fitting (33).

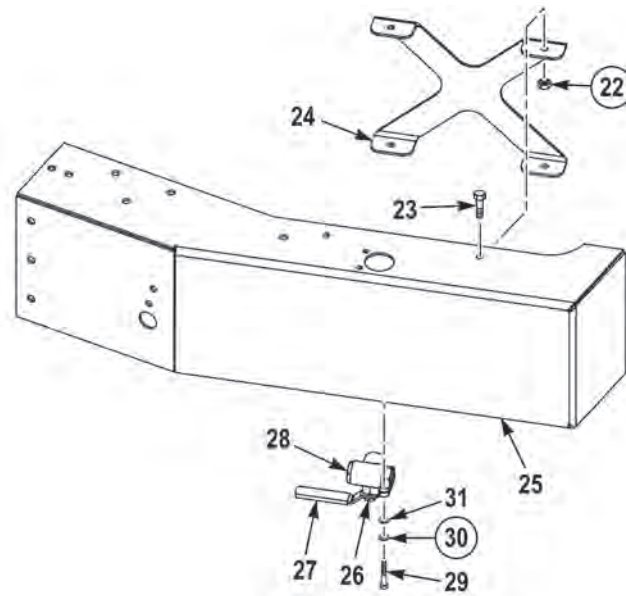

7. Install two valves (28) on driver side bumper (25) with four washers (31), new lockwashers (30), and screws (29).
8. Install two handles (27) on two valves (28) with two nuts (26).
9. Install bracket (24) on driver side bumper (25) with four screws (23) and new locknuts (22).

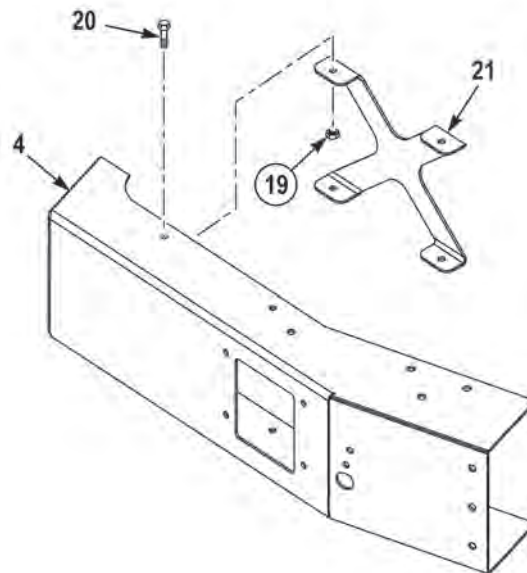

### NOTE

Perform Steps (10) through (12) to install passenger side bumper.

10. Install bracket (21) on passenger side bumper (4) with four screws (20) and new locknuts (19).

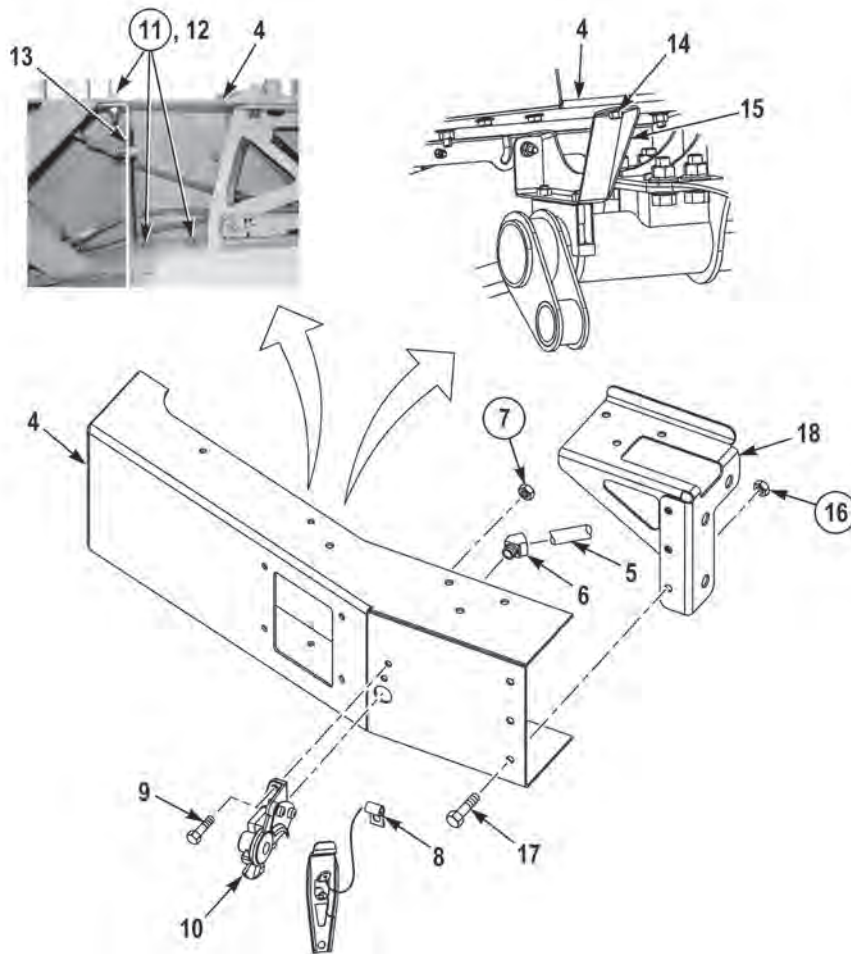

11. Install passenger side bumper (4) on bracket (18) with three screws (17) and new locknuts (16).
12. Install screw (14) on bracket (15) and passenger side bumper (4).
13. Install three screws (12) and locknuts (11) on passenger side bumper (4) and bracket (13).
14. Install gladhand assembly (10) and cushion clip (8) on passenger side bumper (4) with two screws (9) and new locknuts (7).
15. Install air line (5) on fitting (6).



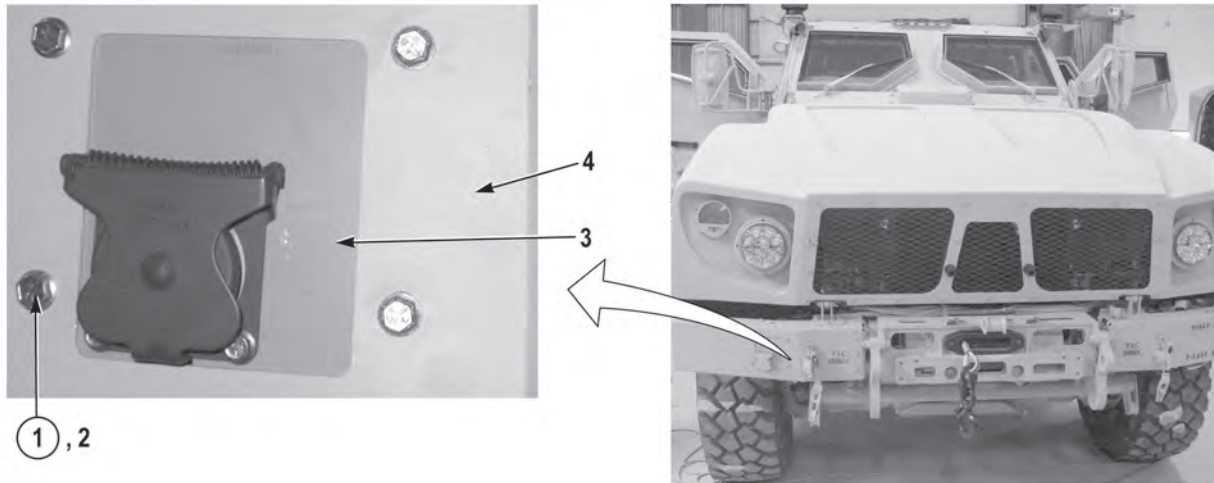

16. Install intervehicular connector assembly (3) on passenger side bumper (4) with four screws (2) and new locknuts (1).
17. Perform all Follow-On Maintenance tasks.

**END OF TASK**

**END OF WORK PACKAGE**



---

**FRONT BUMPER REPLACEMENT (UPDATED SPARK)**

---

**Preconditions**

Park vehicle  
 Engine OFF  
 Wheels chocked  
 Air system drained  
 Front bumper fire suppression cylinders and brackets removed (WP 0068)

**Tools and Special Tools**

Cap and Plug Set  
 Tool Kit, General Mechanic's: Automotive

**Materials/Parts**

Locknut (4) (Item 1)  
 Locknut (2) (Item 7)  
 Locknut (Item 11)

**Materials/Parts (continued)**

Locknut (6) (Item 15)  
 Locknut (4) (Item 17)  
 Locknut (2) (Item 32)  
 Locknut (Item 37)  
 Locknut (6) (Item 40)  
 Locknut (4) (Item 42)  
 Lockwasher (4) (Item 51)  
 Tags, Identification

**Follow-On Maintenance**

Install front bumper fire suppression cylinders and brackets (WP 0068)  
 Remove and stow wheel chocks

---

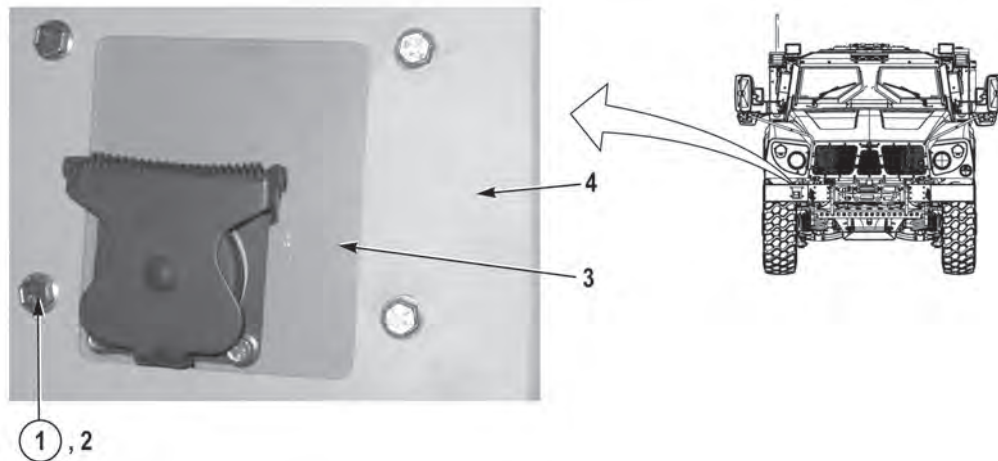
**PASSENGER SIDE FRONT BUMPER REMOVAL**

1. Remove four locknuts (1), screws (2), and intervehicular connector assembly (3) from bumper (4). Discard locknuts (1).

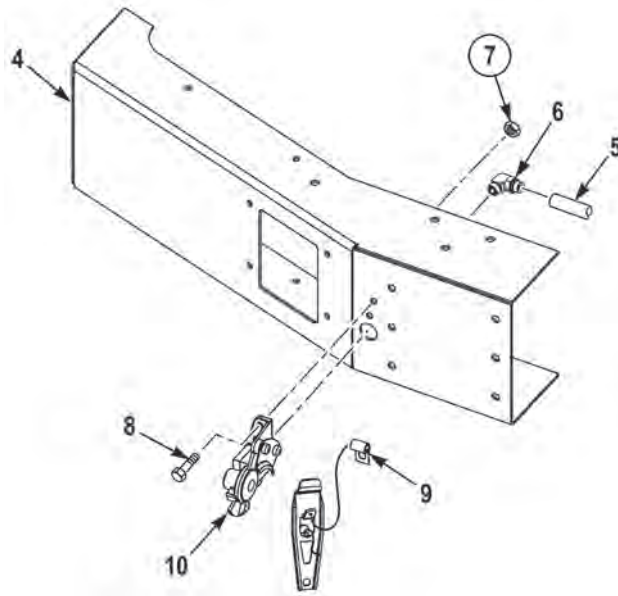

### **WARNING**

**Ensure air system is drained prior to working on air system components. Failure to comply may result in injury or death to personnel.**

### **NOTE**

- Tag and mark air lines prior to removal to ensure proper installation.
  - Cap and plug air lines and fittings upon removal.
2. Remove air line (5) from fitting (6).
  3. Remove two locknuts (7), screws (8), cushion clip (9), and gladhand assembly (10) from bumper (4). Discard locknuts (7).

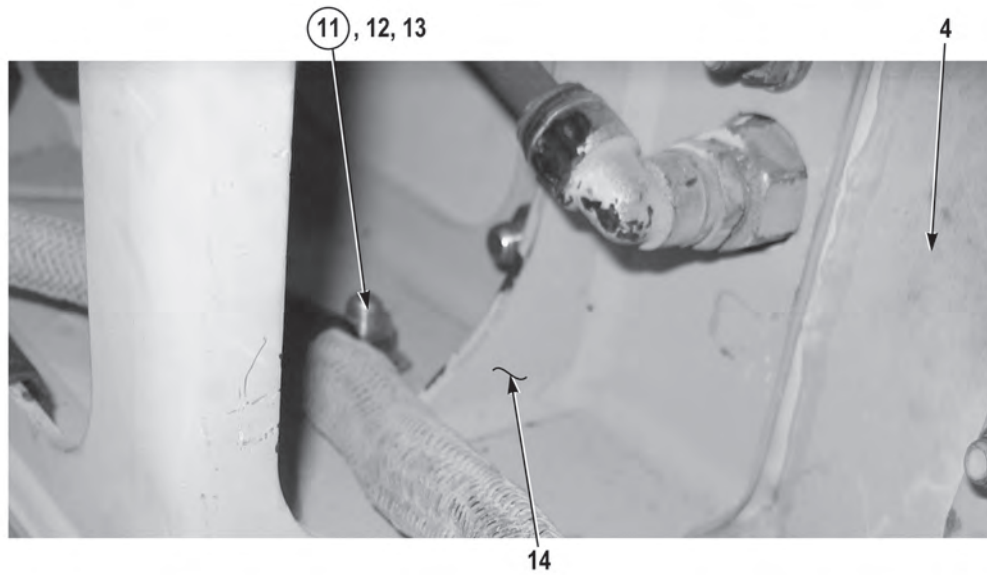

4. Remove locknut (11), cushion clip (12), and screw (13) from bracket (14) and bumper (4). Discard locknut (11).

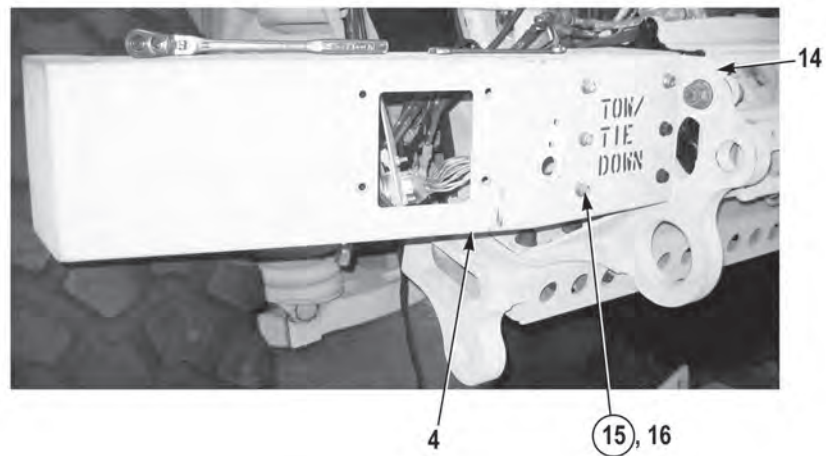

5. Remove six locknuts (15), screws (16), and bumper (4) from bracket (14). Discard locknuts (15).

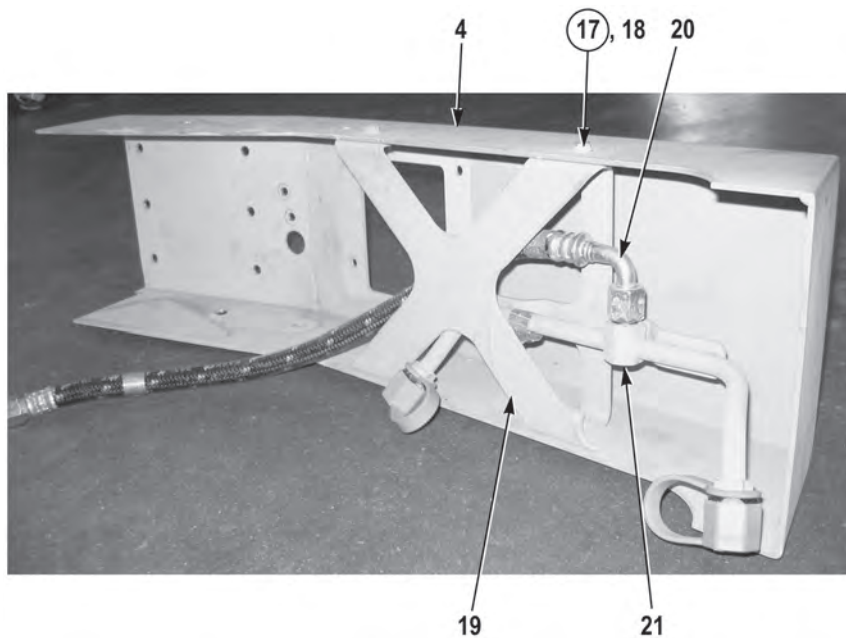

- Remove four locknuts (17), screws (18), stiffener (19), hose (20), and tube assembly (21) from bumper (4). Discard locknuts (17).

#### END OF TASK

#### PASSENGER SIDE FRONT BUMPER INSTALLATION

- Install tube assembly (21), hose (20), and stiffener (19) on bumper (4) with four screws (18) and new locknuts (17).

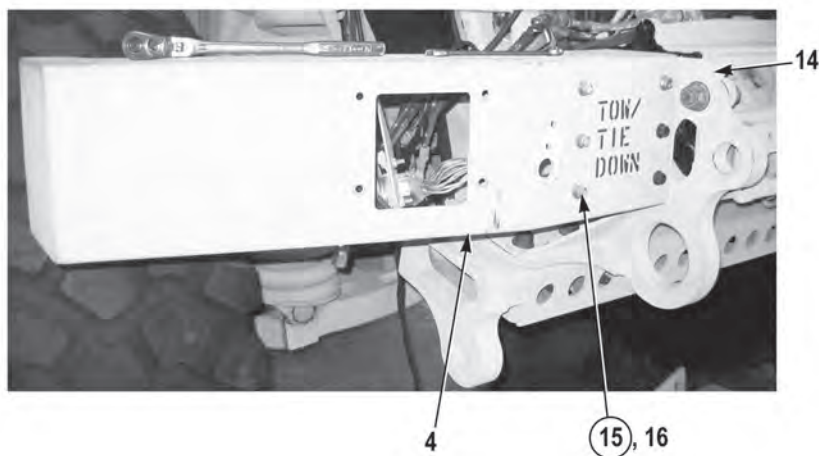

- Install bumper (4) on bracket (14) with six screws (16) and new locknuts (15).



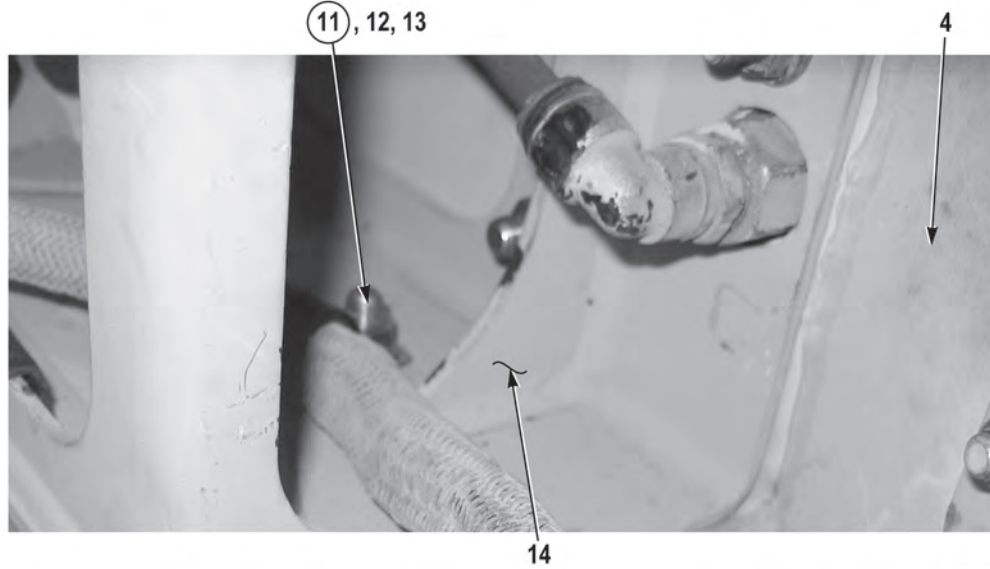

3. Install cushion clip (12) on bumper (4) and bracket (14) with screw (13) and new locknut (11).

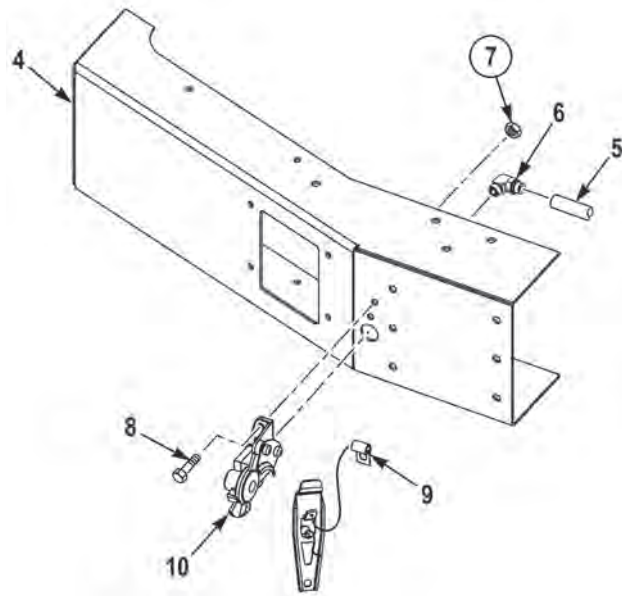

4. Install gladhand assembly (10) and cushion clip (9) on bumper (4) with two screws (8) and new locknuts (7).
5. Install air line (5) on fitting (6).

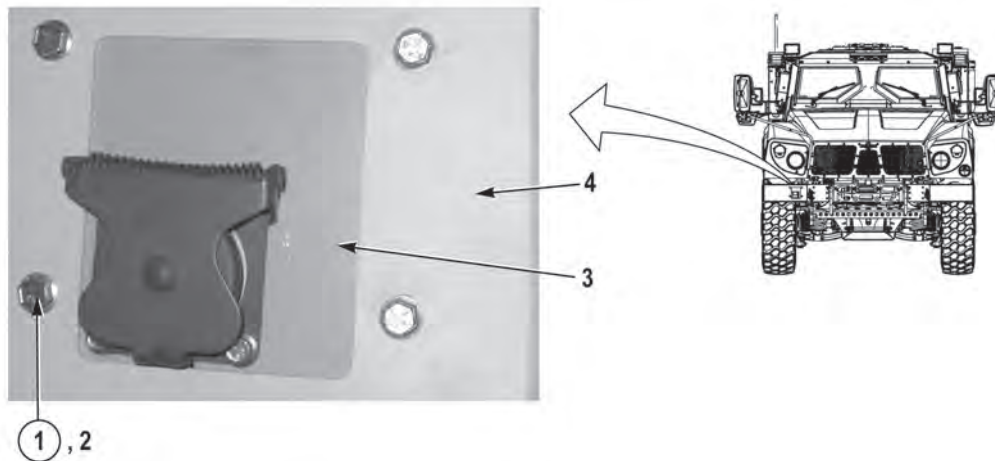

6. Install intervehicular connector assembly (3) on bumper (4) with four screws (2) and new locknuts (1).

**END OF TASK**

**DRIVER SIDE FRONT BUMPER REMOVAL**

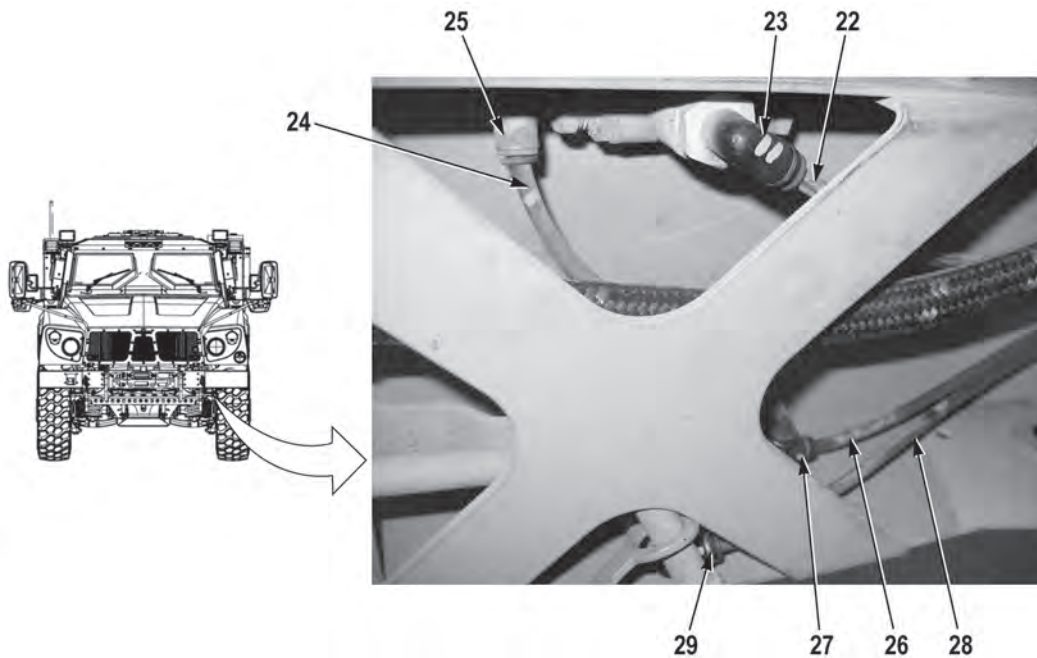

**WARNING**

Ensure air system is drained prior to working on air system components. Failure to comply may result in injury or death to personnel.

**NOTE**

- Tag and mark air lines prior to removal to ensure proper installation.
- Cap and plug air lines and fittings upon removal.

1. Remove air line (22) from fitting (23).
2. Remove air line (24) from fitting (25).
3. Remove air line (26) from fitting (27).
4. Remove air line (28) from fitting (29).

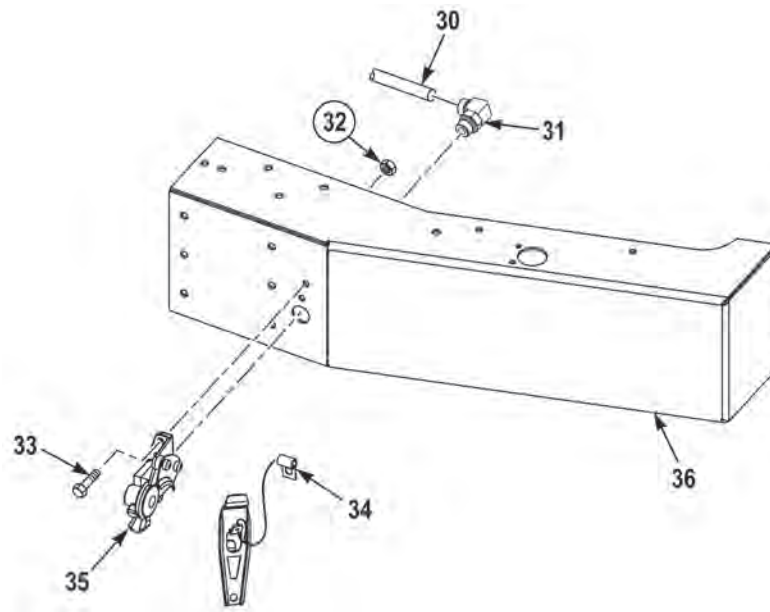

5. Remove air line (30) from fitting (31).
6. Remove two locknuts (32), screws (33), cushion clip (34), and gladhand assembly (35) from bumper (36). Discard locknuts (32).

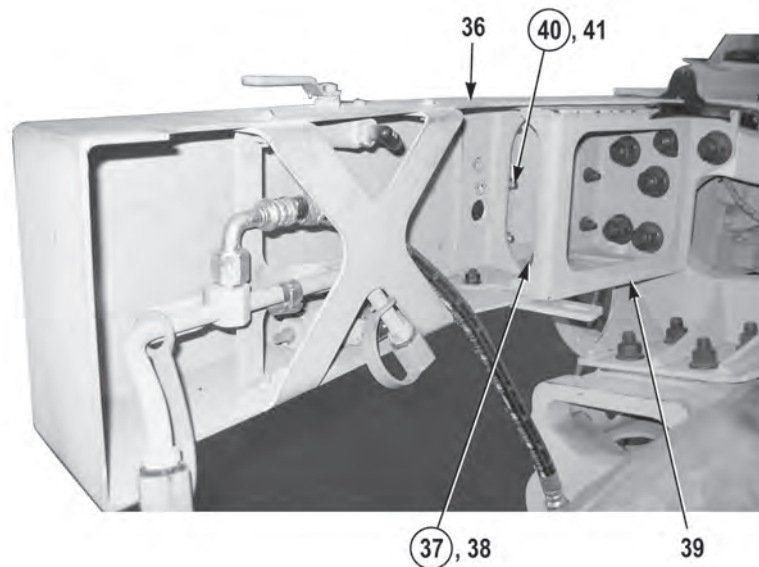

7. Remove locknut (37) and screw (38) from bracket (39) and bumper (36). Discard locknut (37).
8. Remove six locknuts (40), screws (41), and bumper (36) from bracket (39). Discard locknuts (40).

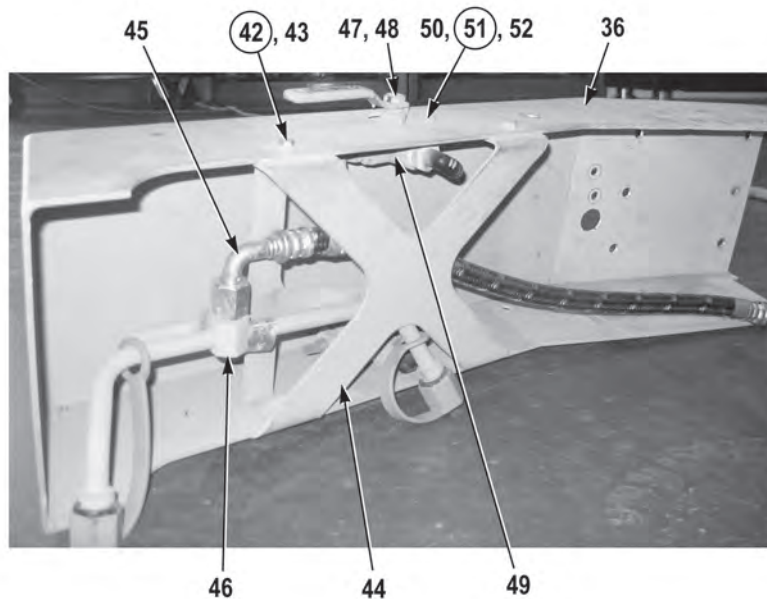

9. Remove four locknuts (42), screws (43), stiffener (44), hose (45), and tube assembly (46) from bumper (36). Discard locknuts (42).

10. Remove two nuts (47) and handles (48) from two valves (49).
11. Remove four screws (50), lockwashers (51), washers (52), and two valves (49) from bumper (36). Discard lockwashers (51).

### END OF TASK

### DRIVER SIDE FRONT BUMPER INSTALLATION

1. Install two valves (49) on bumper (36) with four washers (52), new lockwashers (51), and screws (50).
2. Install two handles (48) on two valves (49) with two nuts (47).
3. Install tube assembly (46), hose (45), and stiffener (44) on bumper (36) with four screws (43) and new locknuts (42).
4. Install bumper (36) on bracket (39) with screw (38) and new locknut (37).
5. Secure bumper (36) on bracket (39) with six screws (41) and new locknuts (40).

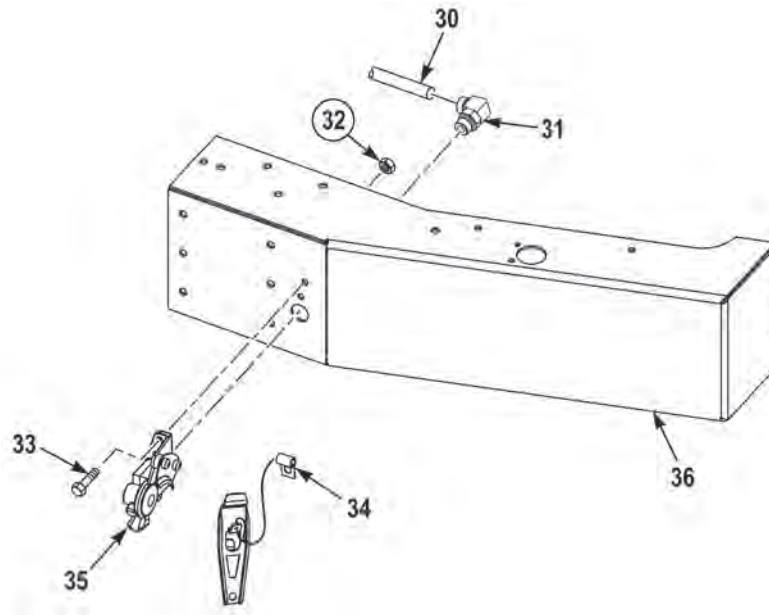

6. Install gladhand assembly (35) and cushion clip (34) on bumper (36) with two screws (33) and new locknuts (32).
7. Install air line (30) on fitting (31).

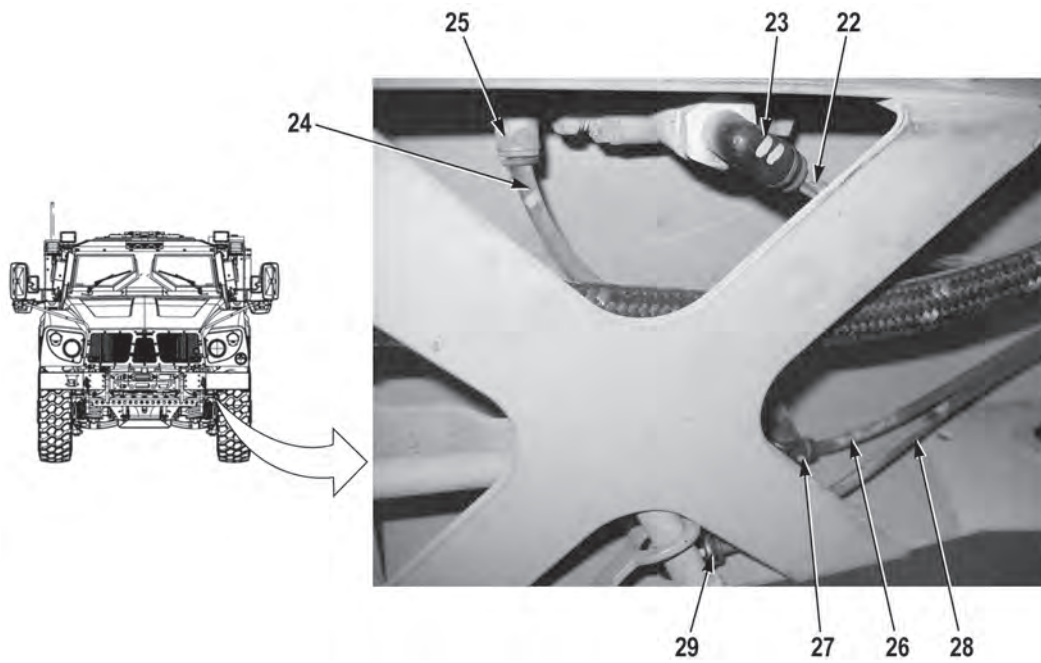

8. Install air line (28) on fitting (29).
9. Install air line (26) on fitting (27).
10. Install air line (24) on fitting (25).
11. Install air line (22) on fitting (23).
12. Perform all Follow-On Maintenance tasks.

**END OF TASK**

**END OF WORK PACKAGE**



---

**GFE CABINET REPLACEMENT (M1245)**

---

**Preconditions**

Park Vehicle  
 Engine OFF  
 Wheels Chocked  
 Batteries Disconnected (WP 0187)  
 PDU Deck Box Removed (WP 0208) (Perform only if removing passenger side GFE cabinet).

**Tools and Special Tools**

Tool Kit, General Mechanic's: Automotive

**Materials/Parts**

Locknut (2) (Item 9)

**Materials/Parts (continued)**

Locknut (6) (Item 11)  
 Locknut (2) (Item 15)  
 Locknut (8) (Item 16)  
 Tags, Identification  
 Ties, Cable

**Follow-On Maintenance**

Install PDU deck box (WP 0208)  
 Connect batteries (WP 0187)  
 Remove and stow wheel chocks

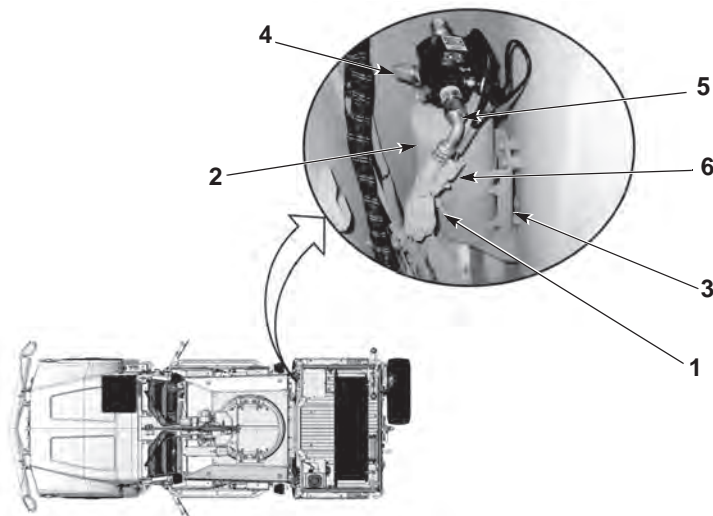
**PASSENGER SIDE GFE CABINET REMOVAL****NOTE**

- Procedure for removing fire suppression bottle from the GFE cabinet is the same for the driver side and passenger side of the vehicle.
  - Tag and mark wires and connectors and note all wire harness routing prior to removal to ensure proper installation.
  - Remove cable ties as required.
1. Disconnect wire connector (6) from the fire suppression bottle (2).
  2. Disconnect the fire suppression disbursement tube (4) from the fire suppression bottle (2).
  3. Disconnect the fire suppression disbursement tube (5) from the fire suppression bottle (2).
  4. Disconnect connector (1), and loosen nut on tension brackets to remove fire suppression bottle (2) from support bracket (3).

## REMOVAL – CONTINUED

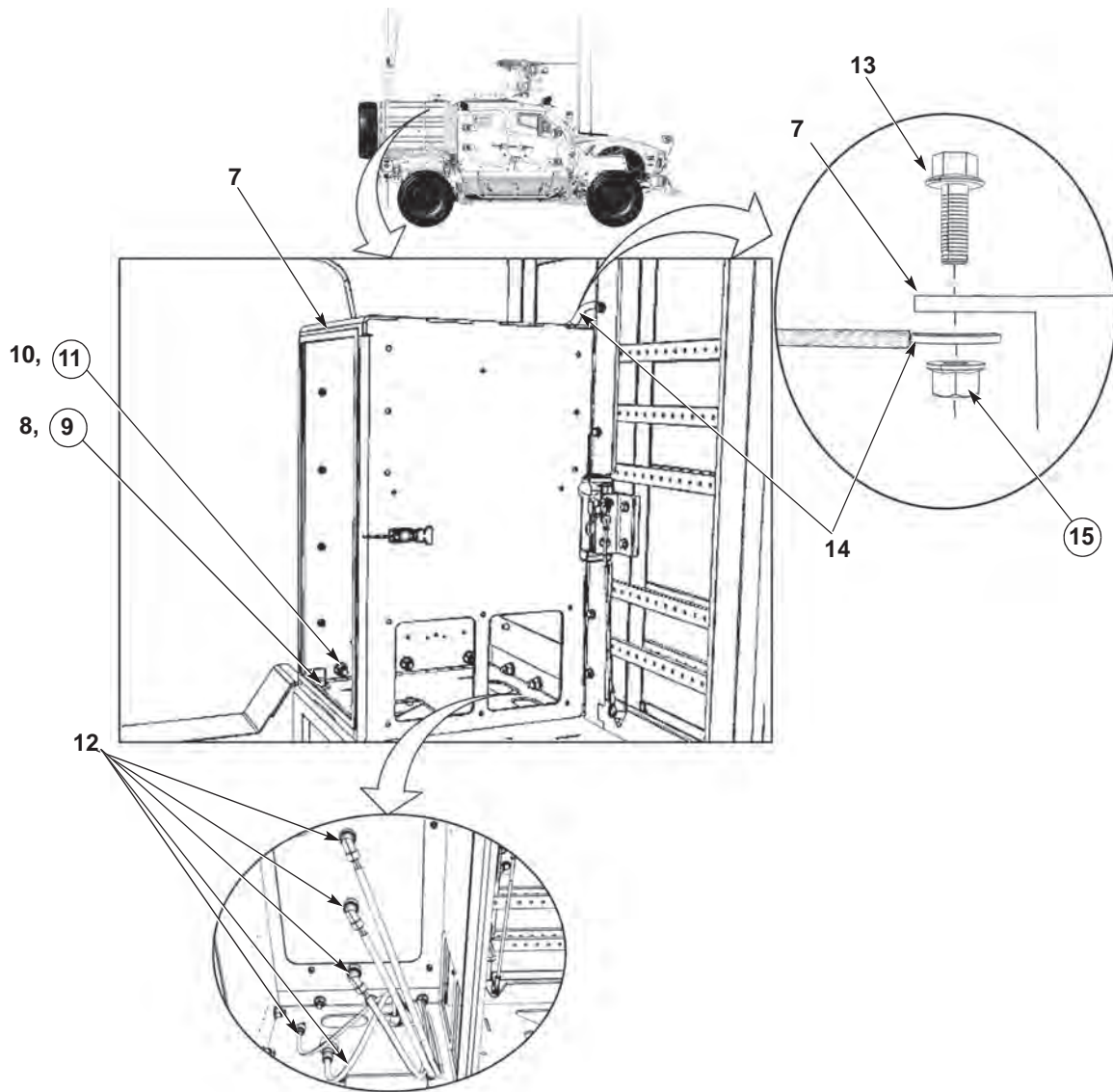
**NOTE**

Tag and mark all wires, connectors and cables also note all routing prior to removal to ensure proper installation.

5. Re-route wire harnesses (12) from the passenger side GFE cabinet (7).
6. Remove two locknuts (9), two screws (8), from the GFE cabinet (7). Discard locknuts.
7. Remove six locknuts (11), six screws (10), from the GFE cabinet (7). Discard locknuts.
8. Remove locknut (15), screw (13) and ground strap (14) from GFE cabinet (7). Discard locknut.

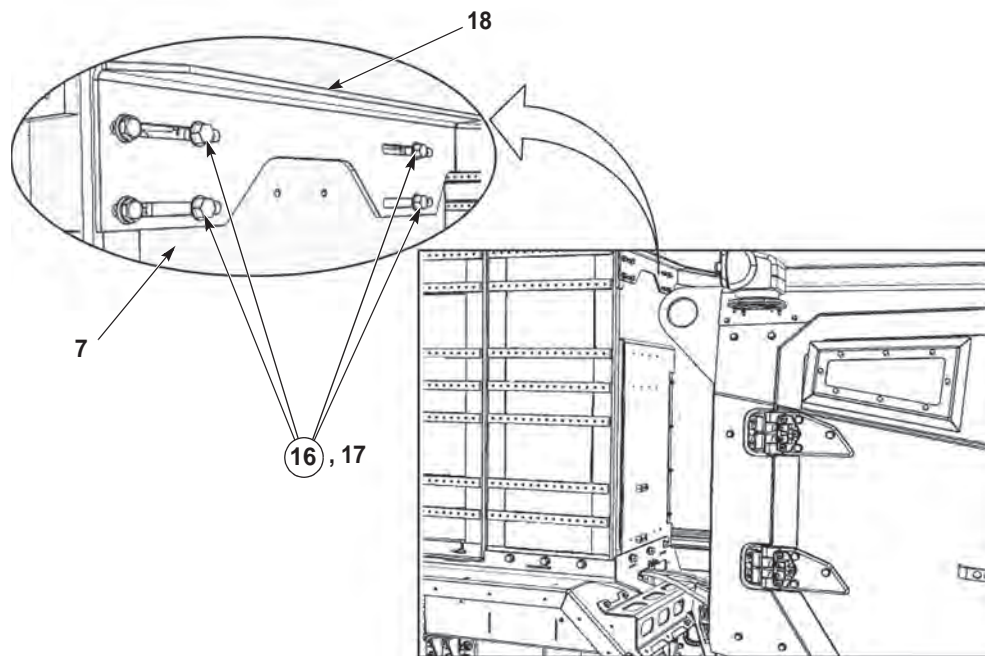
**REMOVAL – CONTINUED**

9. Remove four locknuts (16) and screws (17) from the cross member (18). Discard locknuts (16).
10. Remove the passenger side GFE cabinet (7) from the cargo deck.

**END OF TASK**

## PASSENGER SIDE GFE CABINET INSTALLATION

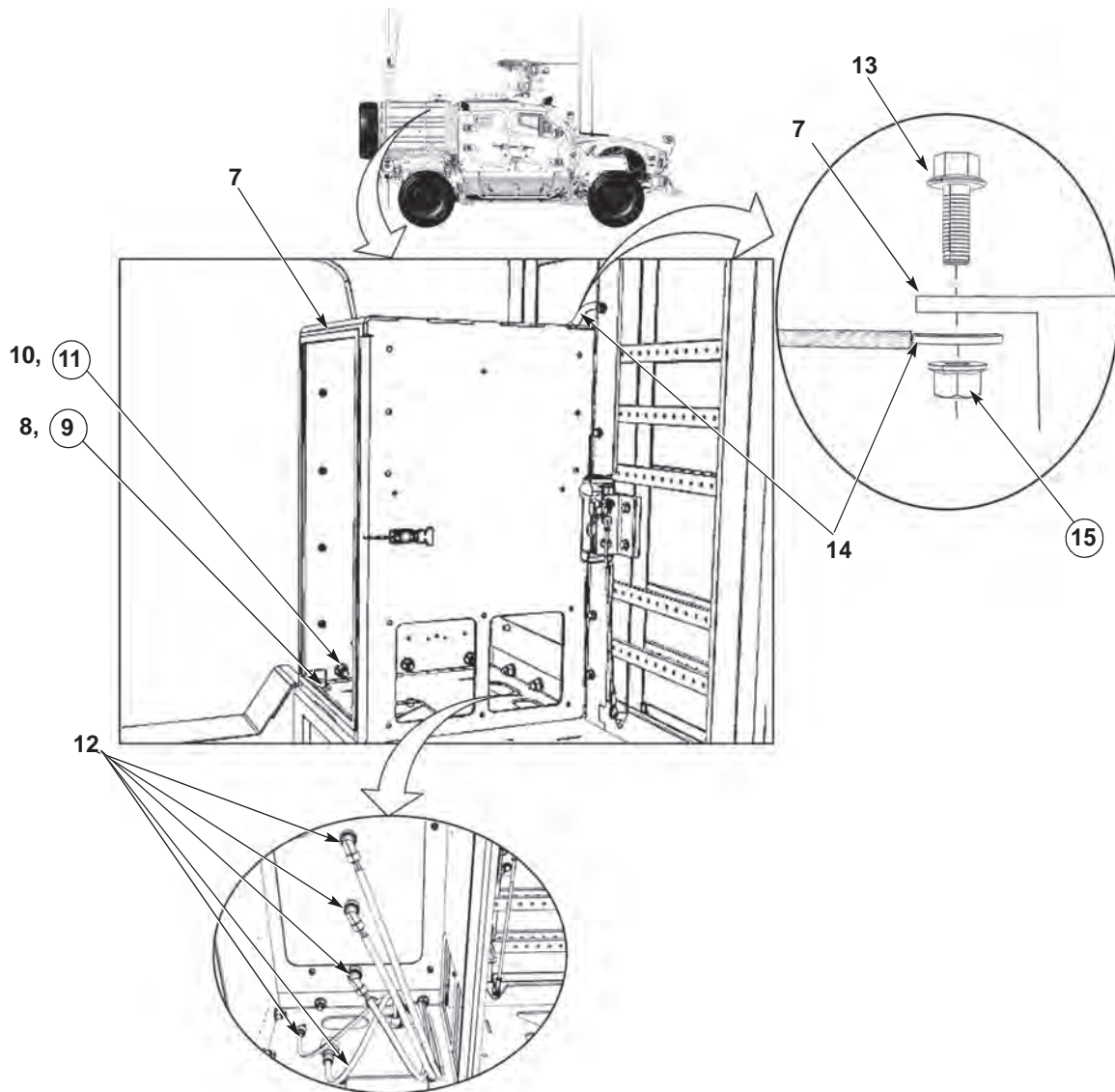
**NOTE**

- Route wire harness and cables as noted prior to removal.
- Install cable ties as needed.

1. Position the passenger side GFE cabinet (7) into the cargo deck.
2. Install six screws (10), six new locknuts (11), securing the GFE cabinet (7).
3. Install two screws (8) two new locknuts (9), securing the GFE cabinet (7).
4. Install ground strap (14) onto GFE cabinet (7) with screw (13) and new locknut (15).
5. Install wire harnesses (12) to passenger GFE cabinet (7).

## INSTALLATION – CONTINUED

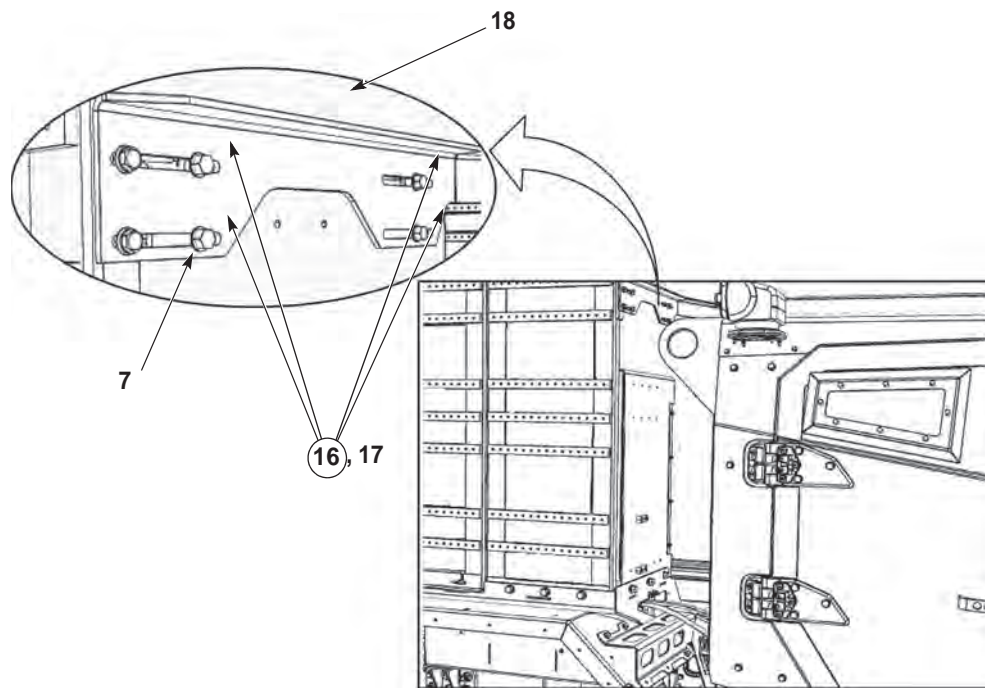

6. Install four screws (17) and four new locknuts (16) securing the cross member (15) to the GFE cabinet (7).

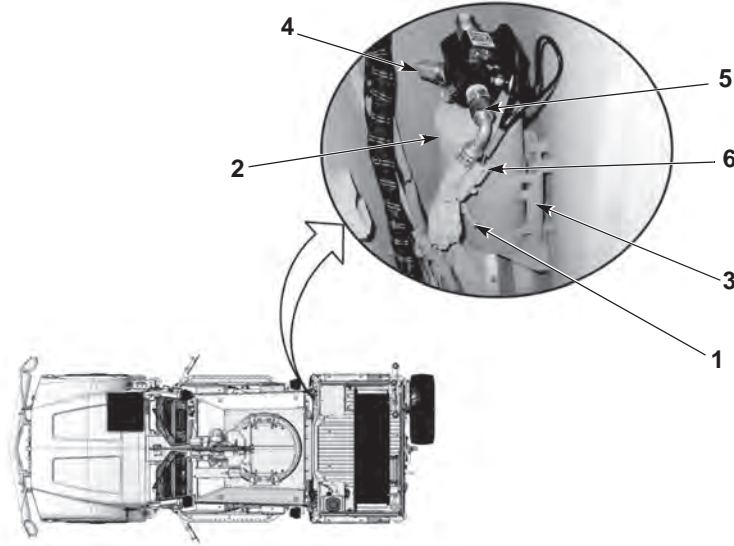
**INSTALLATION – CONTINUED****NOTE**

- Procedure for installing fire suppression bottle to the GFE cabinet is the same for the driver side and passenger side of the vehicle.
- Install cable ties as required.

7. Install fire suppression bottle (2) to the support bracket (3), tighten tension brackets and connect electrical connector (1).
8. Connect the fire suppression disbursement tube (5) to the fire suppression bottle (2).
9. Connect the fire suppression disbursement tube (4) to the fire suppression bottle (2).
10. Connect wire connector (6) to the fire suppression bottle (2).
11. Perform all Follow-On maintenance Tasks.

**END OF TASK**

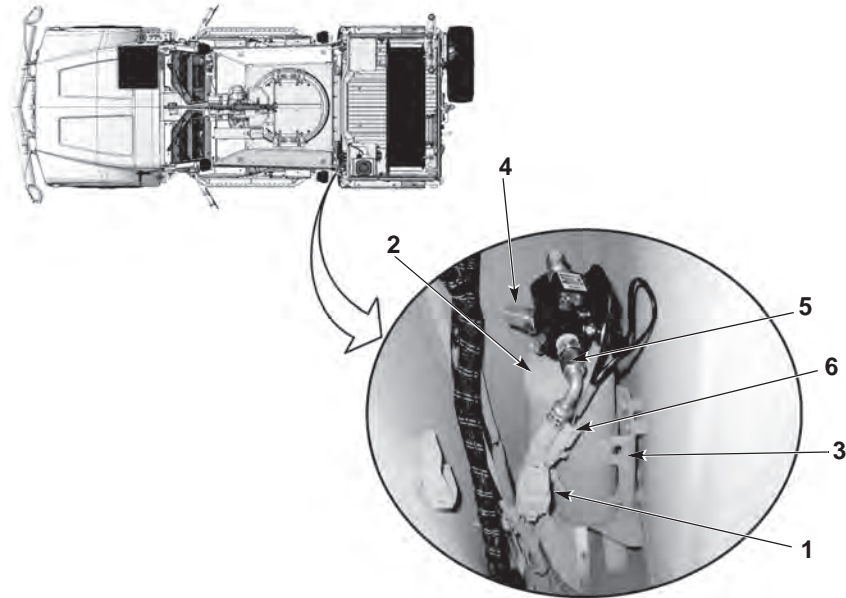

**DRIVER SIDE GFE CABINET REMOVAL****NOTE**

- Procedure for removing fire suppression bottle from the GFE cabinet is the same for the driver side and passenger side of the vehicle.
- Tag and mark wires and connectors and note all wire harness routing prior to removal to ensure proper installation.
- Remove cable ties as required.

1. Disconnect wire connector (6) from the fire suppression bottle (2).
2. Disconnect the fire suppression disbursement tube (4) from the fire suppression bottle (2).
3. Disconnect the fire suppression disbursement tube (5) from the fire suppression bottle (2).
4. Disconnect electrical connector (1), loosen nut on tension bracket and remove fire suppression bottle (2) from support bracket (3).

## REMOVAL – CONTINUED

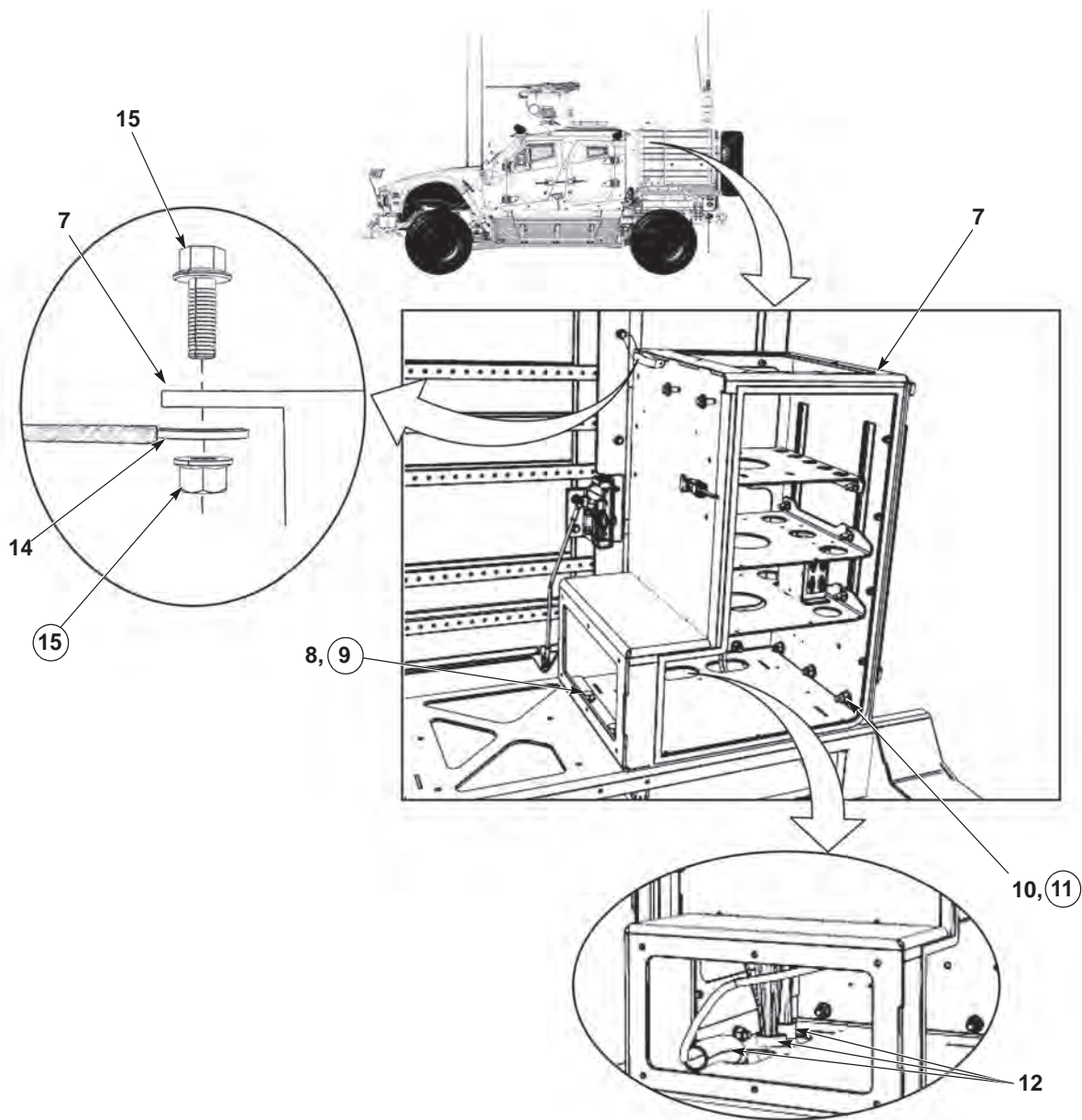
**NOTE**

Tag and mark all wires, connectors and cables also note all routing prior to removal to ensure proper installation.

5. Re-route all wire harnesses (12) from the driver side GFE cabinet (7).
6. Remove two locknuts (9), two screws (8), from the GFE cabinet (7). Discard locknuts.
7. Remove six locknuts (11), six screws (10), from the GFE cabinet (7). Discard locknuts.
8. Remove locknut (15) ground strap (14) and screw (13) from GFE cabinet (7). Discard locknut.

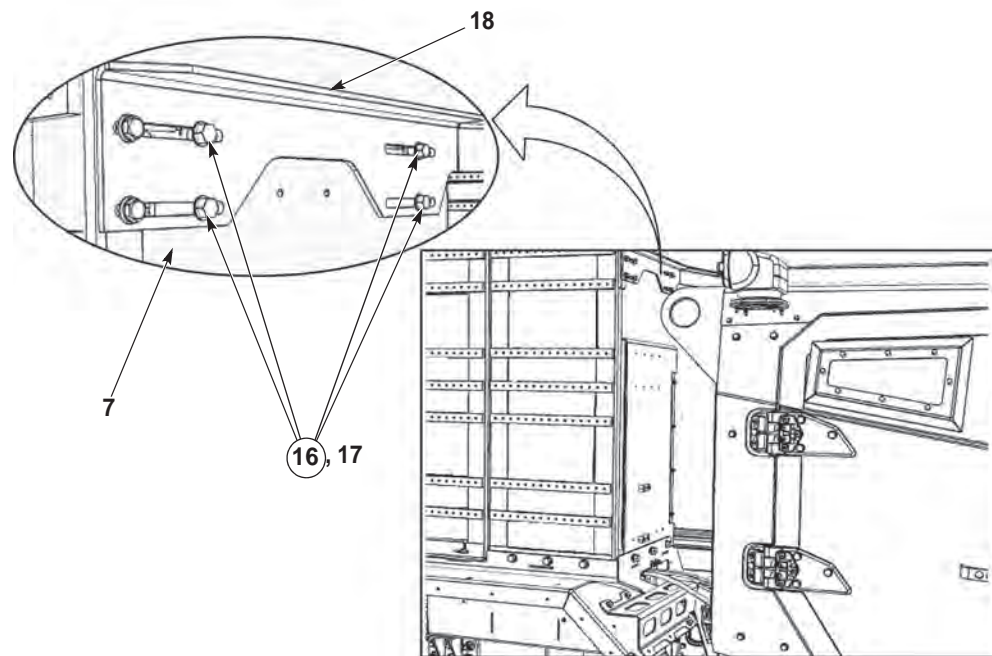
**REMOVAL – CONTINUED**

9. Remove four locknuts (16) and screws (17) from the cross member (18). Discard locknuts (16).
10. Remove the driver side GFE cabinet (7) from the cargo deck.

**END OF TASK**

## DRIVER SIDE GFE CABINET INSTALLATION

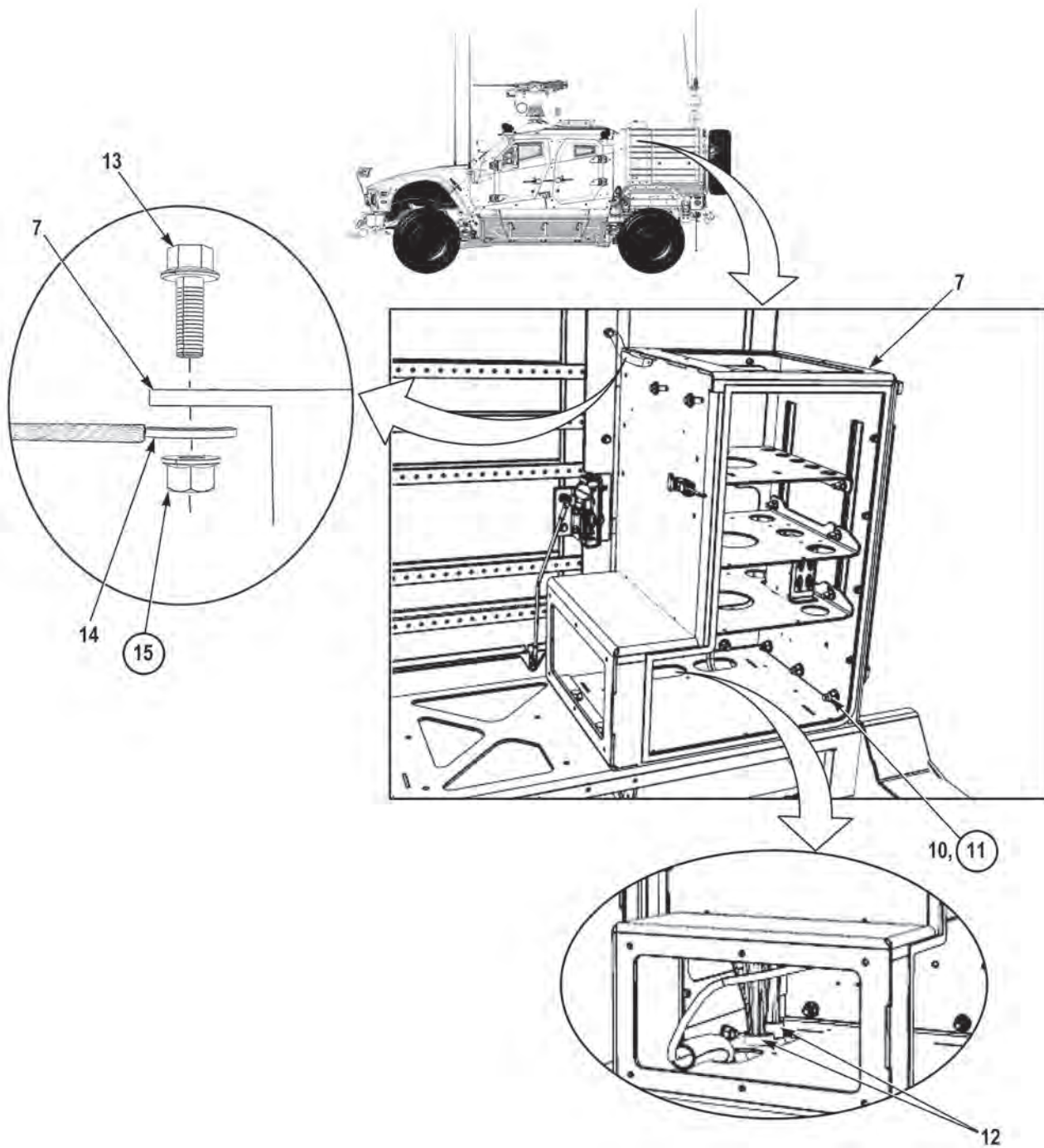
**NOTE**

- Route wire harness and cables as noted prior to removal.
- Install cable ties as needed.

1. Position the passenger side GFE cabinet (7) into the cargo deck.
2. Install six screws (10), six new locknuts (11), securing the GFE cabinet (7).

**INSTALLATION – CONTINUED**

3. Install two screws (8) two new locknuts (9), securing the GFE cabinet (7).
4. Install wire harnesses (12) to passenger GFE cabinet (7).
5. Install ground strap (14) onto GFE cabinet (7) with screw (13) and new locknut (15).

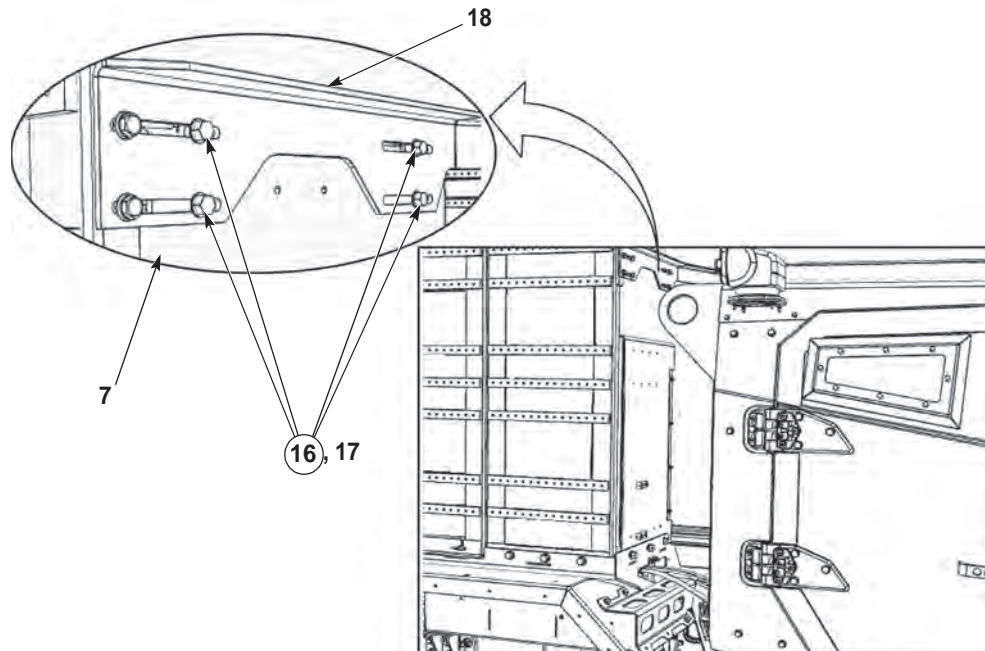

6. Install four screws (17) and four new locknuts (16) securing the cross member (18) to the GFE cabinet.

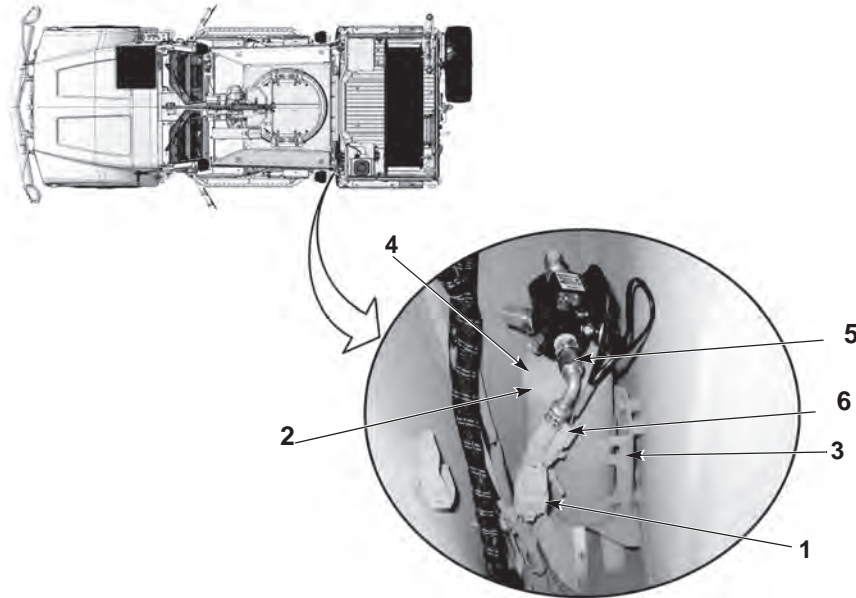
**INSTALLATION – CONTINUED****NOTE**

- Procedure for installing fire suppression bottle to the GFE cabinet is the same for the driver side and passenger side of the vehicle.
- Install cable ties as required.

7. Install fire suppression bottle (2) to the support bracket (3), tighten tension brackets and connect electrical connector (1).
8. Connect the fire suppression discharge tube (5) to the fire suppression bottle (2).
9. Connect the fire suppression discharge tube (4) to the fire suppression bottle (2).
10. Connect wire connector (6) to the fire suppression bottle (2).
11. Perform all Follow-On maintenance Tasks.

**END OF TASK****END OF WORK PACKAGE**



---

## PUSH BUMPER REPLACEMENT (M1245)

---

**Preconditions**

Park Vehicle  
 Engine OFF  
 Wheels Chocked

**Tools and Special Tools**

Lifting Device  
 Wrench, Combination, 1-1/8"  
 Socket, 3/4" Dr, 1-1/8"  
 Breaker Bar, 3/4" Dr  
 2" Extension 3/4" Dr  
 Wrench, Torque, 3/4" Dr, 0 - 600 ft-lb  
 Lifting Straps

**Materials/Parts**

Locknut (2) (Item 2)  
 Locknut (2) (Item 5)

**Personnel Required**

Two

**Follow-On Maintenance**

Remove and Stow Wheel Chocks

---

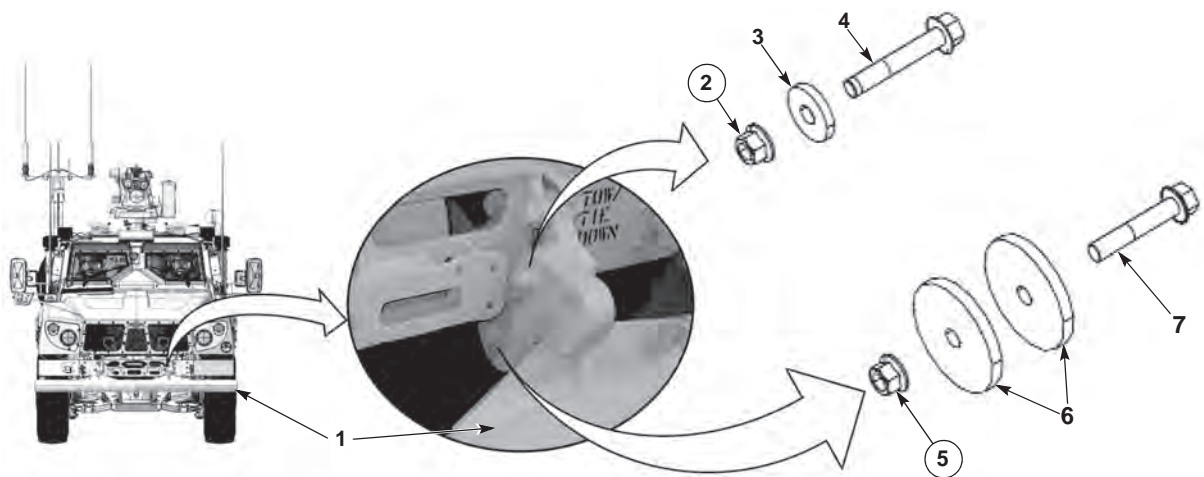
**REMOVAL****WARNING**

**Push bumper is 310 lbs (140 kg). Do not attempt to lift or move push bumper without aid of an assistant and lifting device. Failure to comply may result in injury or death to personnel.**

1. Position lifting straps around front push bumper (1) and support with lifting device.
2. Remove locknut (2), spacer (3), and screw (4). Discard locknut (2).
3. Remove locknut (5), two spacers (6) and screw (7). Discard locknut (5).
4. Repeat steps 1–3 to remove passenger side mounting hardware.
5. With the aid of assistant and lifting device, slide push bumper toward the passenger side and remove push bumper from vehicle.

**END OF TASK**

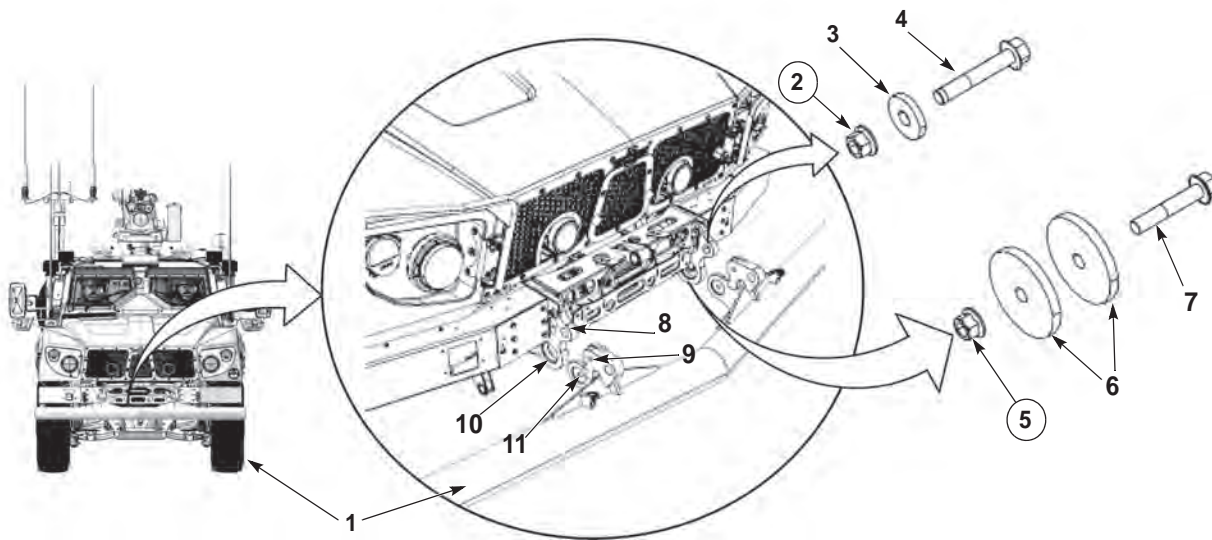
**INSTALLATION****WARNING**

**Push bumper is 310 lbs (140 kg). Do not attempt to lift or move push bumper without aid of an assistant and lifting device. Failure to comply may result in injury or death to personnel.**

1. Attach lifting straps to push bumper (1).
2. With the aid of assistant and lifting device, position push bumper (1) on vehicle.
3. Align holes (8 and 9) on passenger side and the driver side, and slide bumper toward driver side.
4. Install and hand tighten spacer (3), screw (4), and locknut (2) through holes (8 and 9) on passenger side and driver side.
5. Align holes (10 and 11) on passenger side and driver side.
6. Install one spacer (6) and screw (7) through holes (8 and 9) on passenger side and driver side.
7. Install one spacer (6) and locknut (5) onto screw (7) on passenger and driver side.
8. Torque screws (4) and locknuts (2 and 5) on passenger and driver side to 280 ft-lbs (380 N-m).
9. Perform all Follow-On Maintenance Tasks.

**END OF TASK**

**END OF WORK PACKAGE**

---

**QUICK LOCK FLOOR REPLACEMENT (M1245)**

---

**Preconditions**

Park Vehicle  
 Engine OFF  
 Wheels Chocked

**Materials/Parts**

Lockwasher (4) (Item 2)  
 Locknut (2) (Item 4)

**Tools and Special Tools**

Lifting Device

**Tools and Special Tools (continued)**

Strap, 20 ft. (1)  
 Single Stud Ring (2)  
 Tool Kit, General Mechanic's: Automotive

**Personnel Required**

Two

**Follow-On Maintenance**

Remove and Stow Wheel Chocks

---

**REMOVAL****NOTE**

Illustrations shown in work package with the cargo deck walls removed are for clarity purposes only.

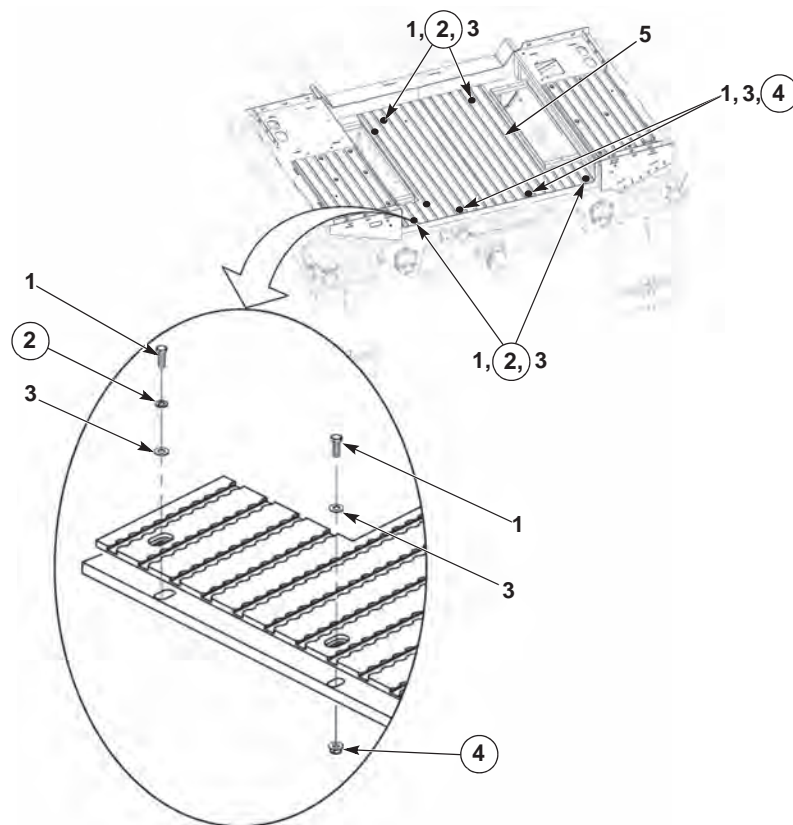

1. Remove six screws (1), four lockwashers (2), six washers (3) and two locknuts (4) from the quick lock floor (5). Discard lockwashers and locknuts.

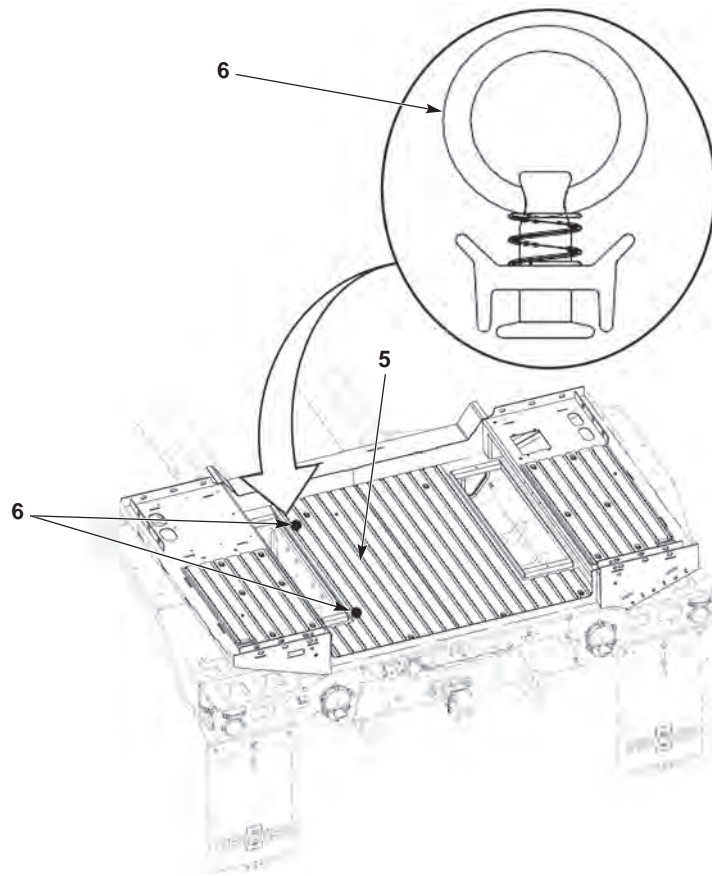
**REMOVAL – CONTINUED**

2. Install two single stud rings (6) evenly to the driver side portion of the quick lock floor (5).

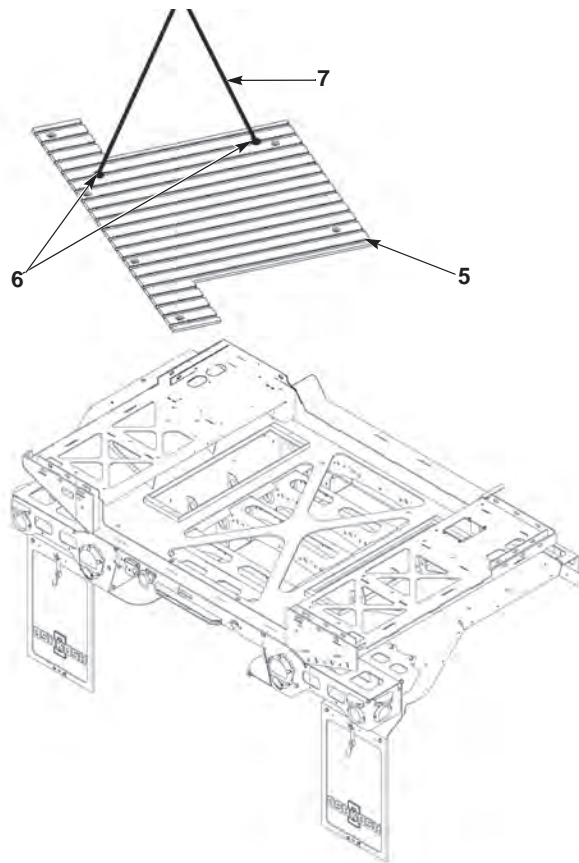
**REMOVAL – CONTINUED****WARNING**

- Keep hands and fingers away from pinch point areas of cargo quick lock floor. Failure to comply may result in injury to personnel.
- Cargo deck quick lock floor weighs approximately 80 lbs (36 kg). Do not lift or move hood without the aid of an assistant and a lifting device. Failure to comply may result in injury or death to personnel.

**NOTE**

The quick lock floor must be lifted at an angle when removing to clear the cargo deck.

3. Attach one 20 ft. strap (7) to the single stud rings (6).
4. With the aid of an assistant and lifting device, remove the quick lock floor (5) from the cargo deck.

**END OF TASK**

## INSTALLATION

### NOTE

Illustrations shown in work package with the cargo deck walls removed are for clarity purposes only.

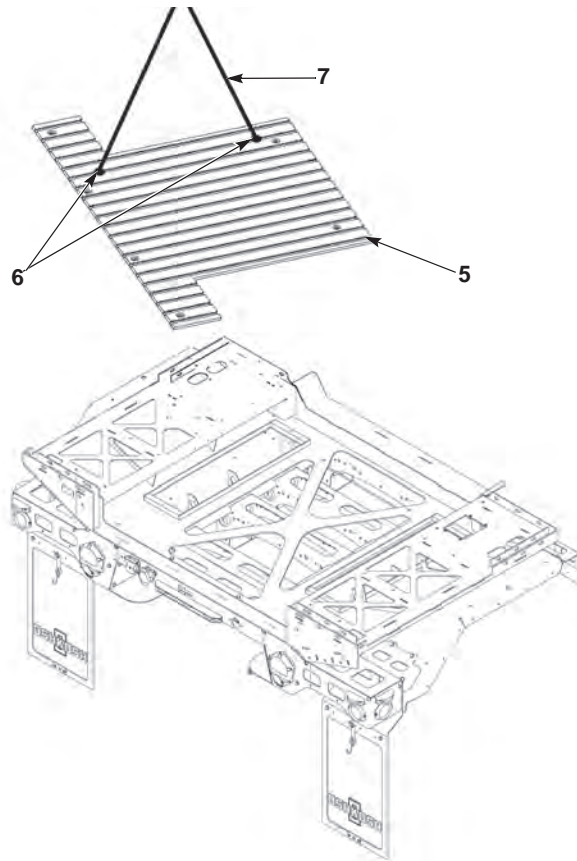

### WARNING

- **Keep hands and fingers away from pinch point areas of cargo quick lock floor. Failure to comply may result in injury to personnel.**
- **Cargo deck quick lock floor weighs approximately 80 lbs (36 kg). Do not lift or move hood without the aid of an assistant and a lifting device. Failure to comply may result in injury or death to personnel.**

### NOTE

The quick lock floor must be lowered at an angle when installing to clear the cargo deck.

1. Attach two 20 ft. straps (7) to the single stud rings (6).
2. With the aid of an assistant and lifting device, install the quick lock floor (5) onto the cargo deck.
3. Remove the 20 ft. strap (7) from single stud rings (6).

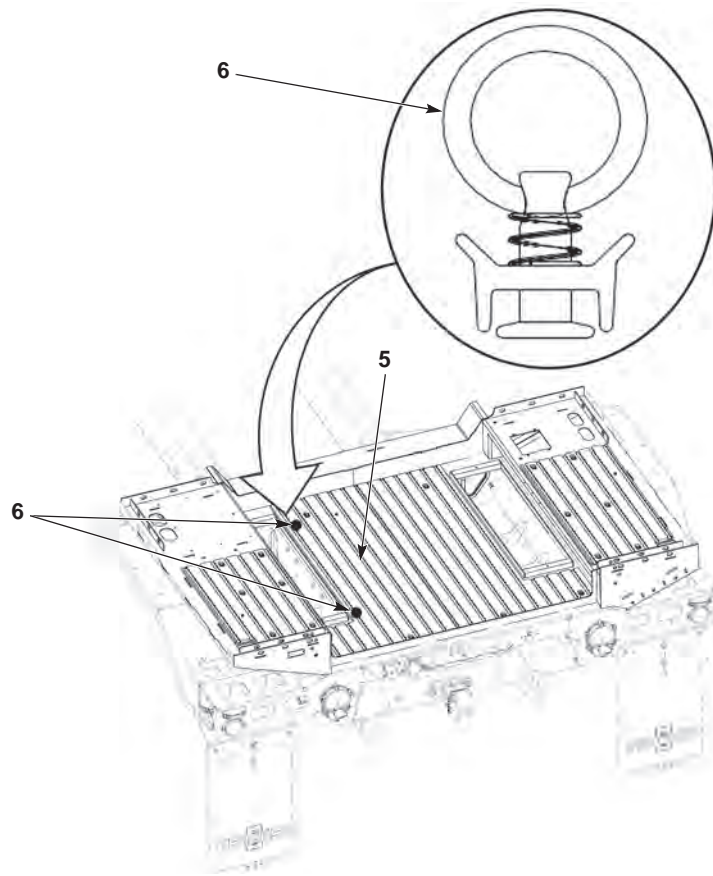

---

**INSTALLATION – CONTINUED**

4. Remove two single stud rings (6) from quick lock floor (5).

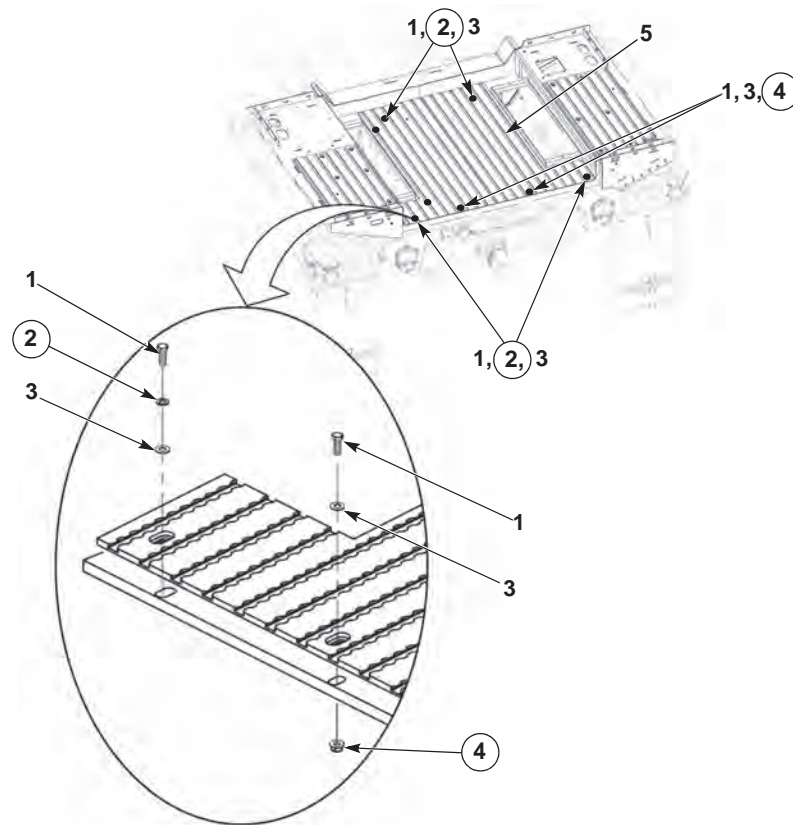
**INSTALLATION – CONTINUED**

5. Install six washers (3), four lockwashers (2) six screws (1), and two locknuts (4), securing the quick lock floor (5) to the cargo deck.
6. Perform all Follow-On maintenance Tasks.

**END OF TASK****END OF WORK PACKAGE**

---

**REAR CROSSMEMBER REPLACEMENT (M1240/M1240A1)**

---

**Preconditions**

Park vehicle  
 Engine OFF  
 Wheels chocked  
 Reverse light removed (WP 0211)  
 Cargo deck removed (WP 0244)  
 Tractor protection valve removed (WP 0137)

**Tools and Special Tools**

Lifting Device  
 Tool Kit, General Mechanic's: Automotive

**Materials/Parts**

Locknut (8) (Item 1)  
 Locknut (4) (Item 6)

**Materials/Parts (continued)**

Locknut (4) (Item 13)  
 Cotter Pin (Item 16)  
 Locknut (4) (Item 25)  
 Locknut (4) (Item 29)  
 Tags, Identification

**Personnel Required**

Two

**Follow-On Maintenance**

Install tractor protection valve (WP 0137)  
 Install cargo deck (WP 0244)  
 Install reverse light (WP 0211)  
 Remove and stow wheel chocks

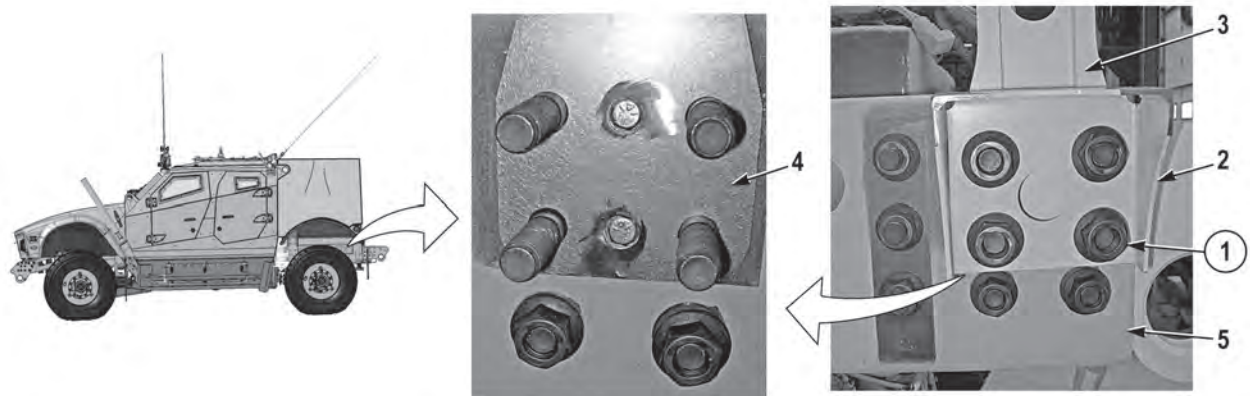
**REMOVAL****NOTE**

- Both cargo deck support brackets and shackle brackets are removed the same way. Driver side shown.
  - A sleeve may be present on one of the screws that secure each side of the rear cargo deck support brackets. If present, note position of sleeve prior to removal to ensure proper installation.
  - Some vehicles may have spacers between the tie-down bracket and frame. If spacers are present, note quantity and thickness of spacers.
1. Remove four locknuts (1), cargo deck support bracket (2), tie-down bracket (3), and spacer(s) (4) from frame (5). Discard locknuts (1).

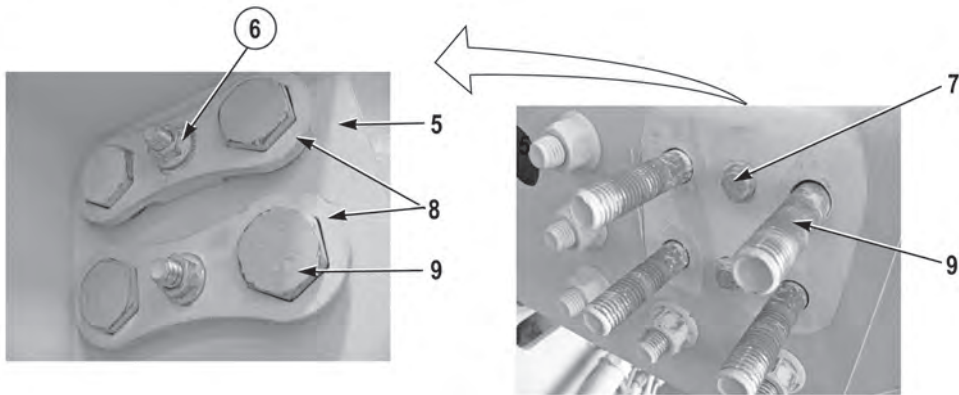

2. Remove two locknuts (6), screws (7), brackets (8), and four screws (9) from frame (5). Discard locknuts (6).
3. Repeat Steps (1) and (2) for passenger side.

**NOTE**

Tag and mark wires prior to removal to ensure proper installation.

4. Remove two nuts (10) and wires (11) from backup alarm (12).

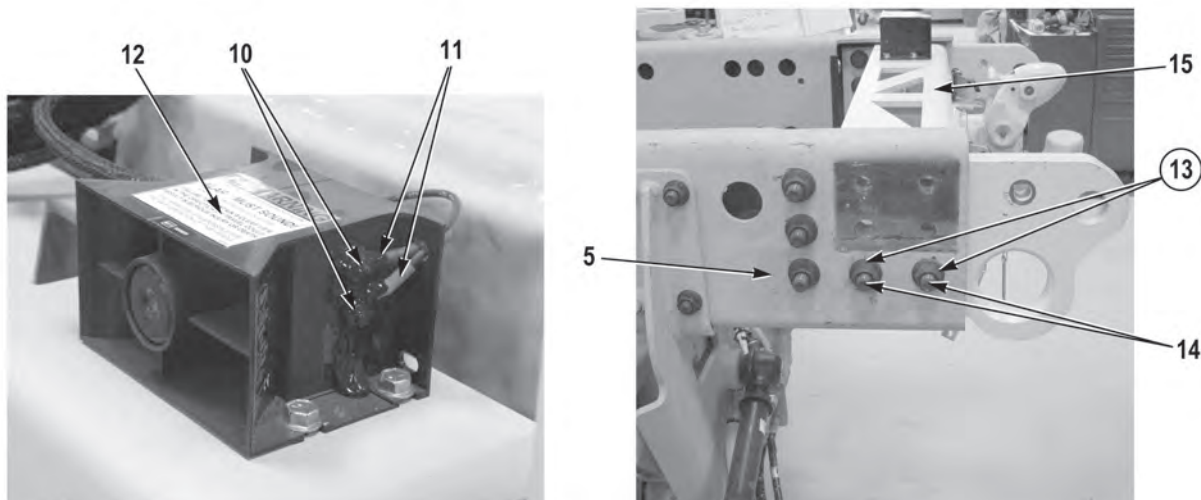

**WARNING**

Rear crossmember weights 110 lbs (50 kg). Do not attempt to lift or move rear crossmember without the aid of an assistant and lifting device. Failure to comply may result in injury or death to personnel.

**NOTE**

Both sides of rear crossmember are removed the same way. Driver side shown.

5. With the aid of an assistant and lifting device, remove four locknuts (13), screws (14), and rear crossmember (15) from frame (5) and vehicle. Discard locknuts (13).

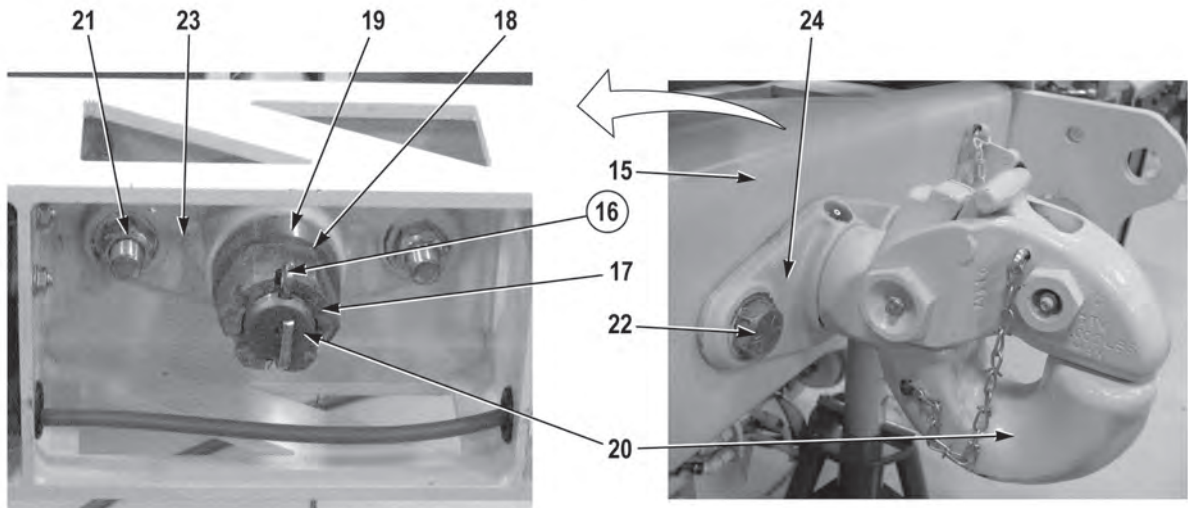

6. Remove cotter pin (16), nut (17), washer (18), spacer (19), and pintle hook (20) from rear crossmember (15). Discard cotter pin (16).
7. Remove two nuts (21), screws (22), bracket (23), and bracket (24) from rear crossmember (15).

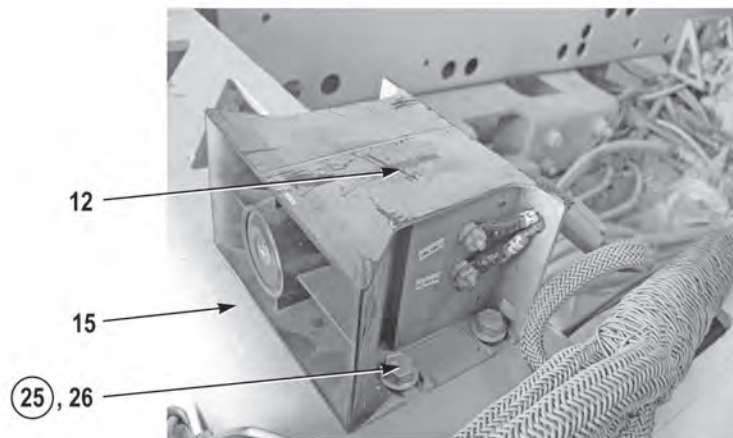

8. Remove four locknuts (25), screws (26), and backup alarm (12) from rear crossmember (15). Discard locknuts (25).

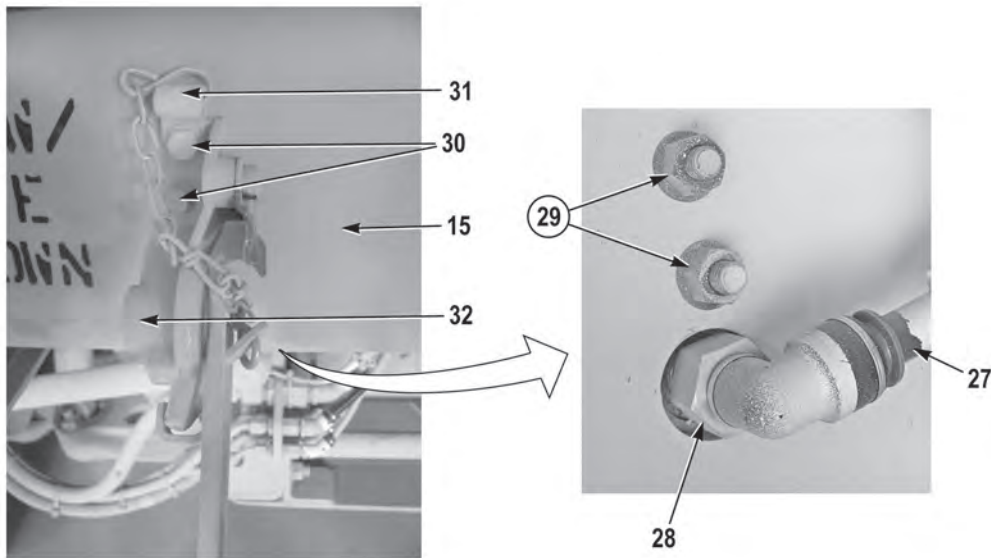

### NOTE

Both gladhand assemblies are removed the same way. Passenger side shown.

9. Remove air line (27) from fitting (28).
10. Remove four locknuts (29), screws (30), two cushion clips (31), and gladhand assemblies (32) from rear crossmember (15). Discard locknuts (29).

### END OF TASK

### INSTALLATION

### NOTE

Both gladhand assemblies are installed the same way. Passenger side shown.

1. Install gladhand assemblies (32) on rear crossmember (15) with two cushion clips (31), four screws (30) and new locknuts (29).
2. Install air line (27) on fitting (28).



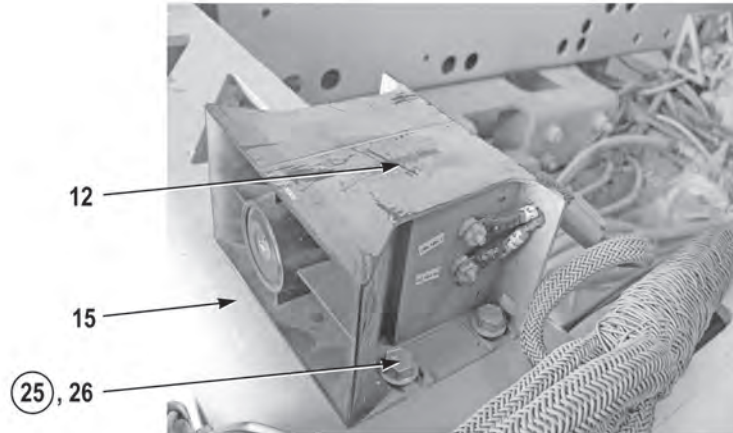

3. Install backup alarm (12) on rear crossmember (15) with four screws (26) and new locknuts (25).

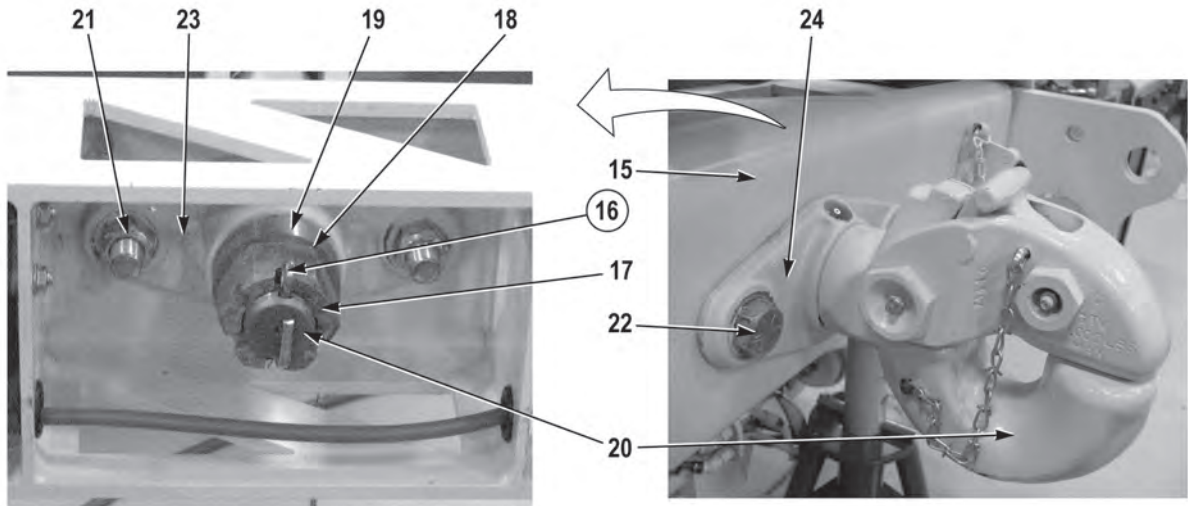

4. Install bracket (24) and bracket (23) on rear crossmember (15) with two screws (22) and nuts (21).
5. Install pintle hook (20) on bracket (24), bracket (23), and rear crossmember (15) with spacer (19), washer (18), and nut (17).

#### NOTE

- When installing nut, tighten nut securely and continue to tighten until cotter pin can be installed.
  - Pintle hook must be able to rotate freely for proper operation.
6. Install new cotter pin (16) in pintle hook (20).

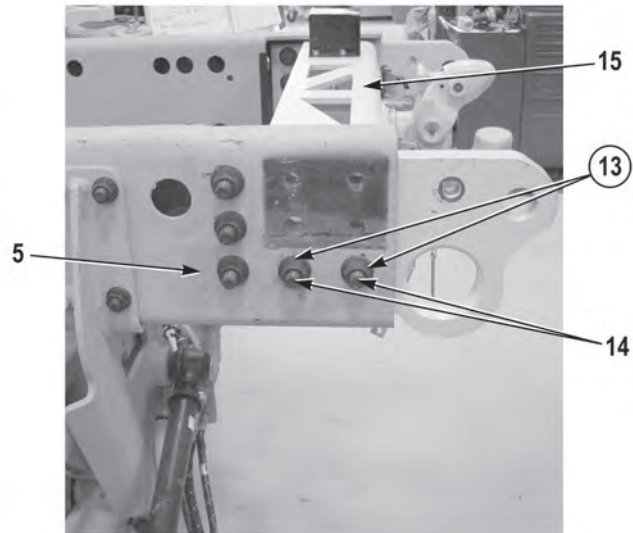
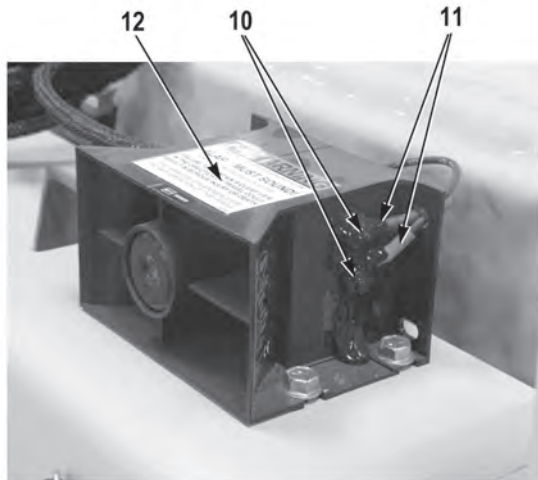

### **WARNING**

Rear crossmember weights 110 lbs (50 kg). Do not attempt to lift or move rear crossmember without the aid of an assistant and lifting device. Failure to comply may result in injury or death to personnel.

### **NOTE**

Both sides of rear crossmember are installed the same way. Driver side shown.

7. With the aid of an assistant and lifting device, install rear crossmember (15) on frame (5) with four screws (14) and new locknuts (13).
8. Repeat Step (7) for passenger side.

### **NOTE**

Install wires as noted prior to removal.

9. Install two wires (11) on backup alarm (12) with two nuts (10).

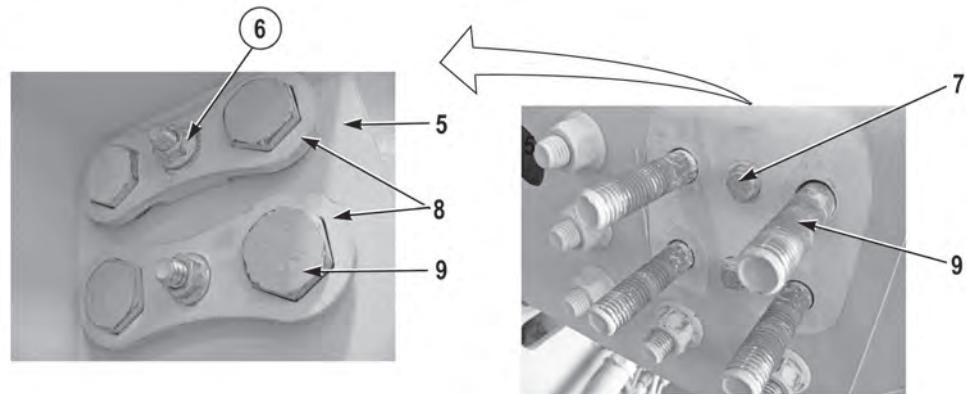

### NOTE

- Both cargo deck support brackets and tie-down brackets are installed the same way. Driver side shown.
- A sleeve may be present on one of the screws that secure each side of the rear cargo deck support brackets. If present, install sleeve as noted prior to removal.

10. Install four screws (9) through frame (5).

11. Install two brackets (8) over screws (9) and secure to frame (5) with screws (7) and new locknuts (6).

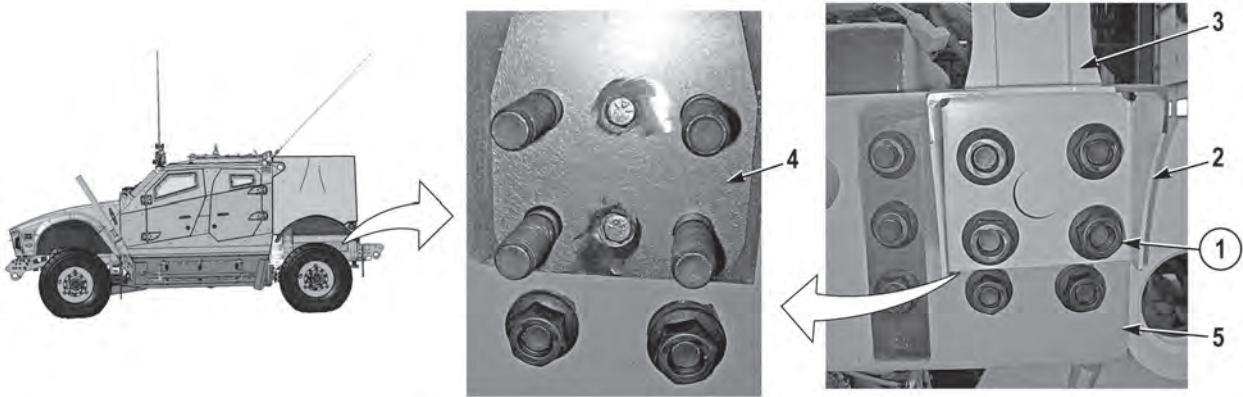

### NOTE

Install tie-down brackets (3) onto frame (5) with tapered top portion of bracket (3) facing towards inside of cargo area.

12. Install spacers (4), tie-down bracket (3), and cargo deck support bracket (2) on frame (5) with four new locknuts (1).
13. Repeat Step (10) through (12) for passenger side.
14. Perform all Follow-On Maintenance tasks.

**END OF TASK**

**END OF WORK PACKAGE**

---

**SPARK BAR AND STRUT REPLACEMENT (UPDATED SPARK)**

---

**Preconditions**

Park vehicle  
 Engine OFF  
 Wheels chocked

**Tools and Special Tools**

Bar, Breaker 3/4 in. Dr.  
 Lifting Device  
 Socket 1 1/8 in., 3/4 in. Dr.  
 Tool Kit, General Mechanic's: Automotive  
 Wrench, Combination, 1 1/8 in.  
 Jack, Transmission

**Materials/Parts**

Compound, Sealing, Loctite 242  
 Locknut (4) (Item 1 and 6)  
 Locknut (12) (Item 10)

**Personnel Required**

Two

**Follow-On Maintenance**

Remove and stow wheel chocks

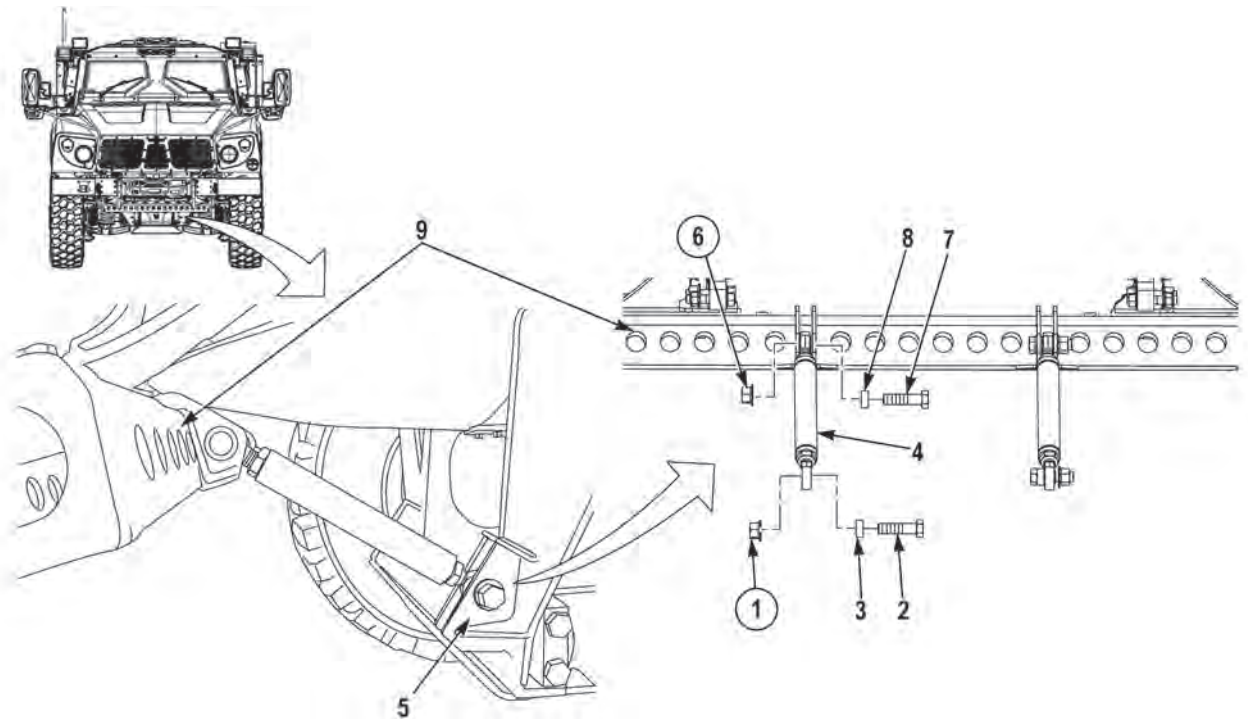
**REMOVAL****NOTE**

- Both support struts are removed the same way. Driver side shown.
- Note position of spacers prior to removal to ensure proper installation.

1. Remove locknut (1), screw (2), and spacer (3) from support strut (4) and two side plate gussets (5). Discard locknut (1).
2. Remove locknut (6), screw (7), spacer (8), and support strut (4) from SPARK bar (9). Discard locknut (6).
3. Repeat Steps (1) and (2) for passenger side support strut.

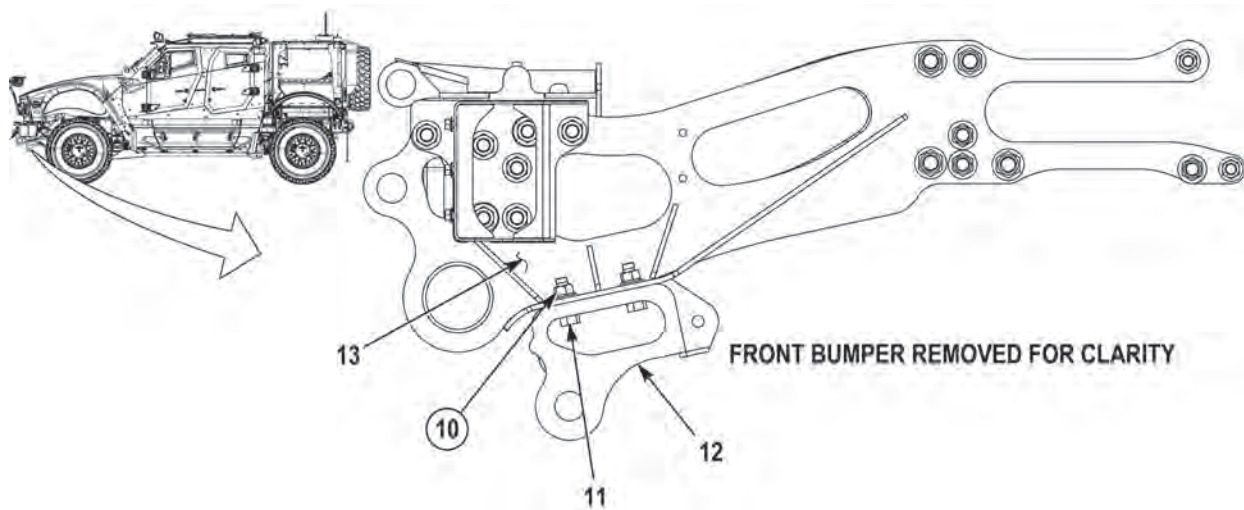

### **WARNING**

**SPARK bar weighs 97 lbs (44 kg). Do not lift or move SPARK bar without the aid of an assistant and lifting device. Failure to comply may result in injury or death to personnel.**

4. With the aid of an assistant and lifting device, remove 12 locknuts (10), screws (11), and SPARK bar (12) from two frame extensions (13). Discard locknuts (10).

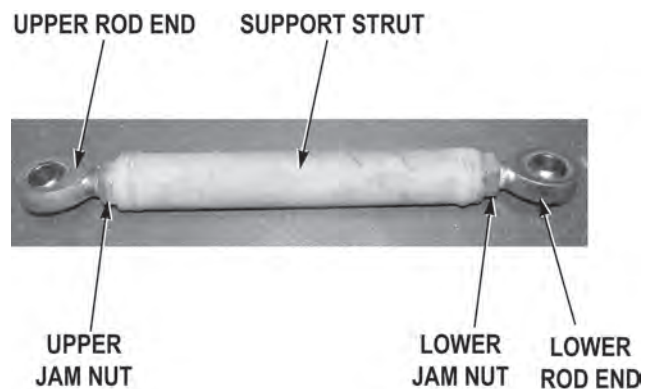

### **NOTE**

Perform Steps (5) through (7) if support strut needs to be disassembled.

5. Loosen upper and lower jam nuts from upper and lower rod ends.
6. Remove upper and lower rod ends and upper and lower jam nuts from support strut.
7. Remove upper and lower jam nuts from upper and lower rod ends.

**END OF TASK**



## INSTALLATION

### NOTE

Perform Steps (1) through (3) if strut was disassembled.

1. Install upper and lower jam nuts on upper and lower rod ends.

### WARNING

**Adhesives, solvents, and sealing compounds can burn easily, can give off harmful vapors, and are harmful to skin and clothing. To avoid injury or death, keep away from open fire and use in well-ventilated area. If adhesive, solvent, or sealing compound gets on skin or clothing, wash immediately with soap and water. Failure to comply may result in injury or death to personnel.**

2. Apply sealing compound, Loctite 242, to threads of upper and lower rod ends and install upper and lower rod ends and upper and lower jam nuts on support strut. Do not tighten jam nuts.

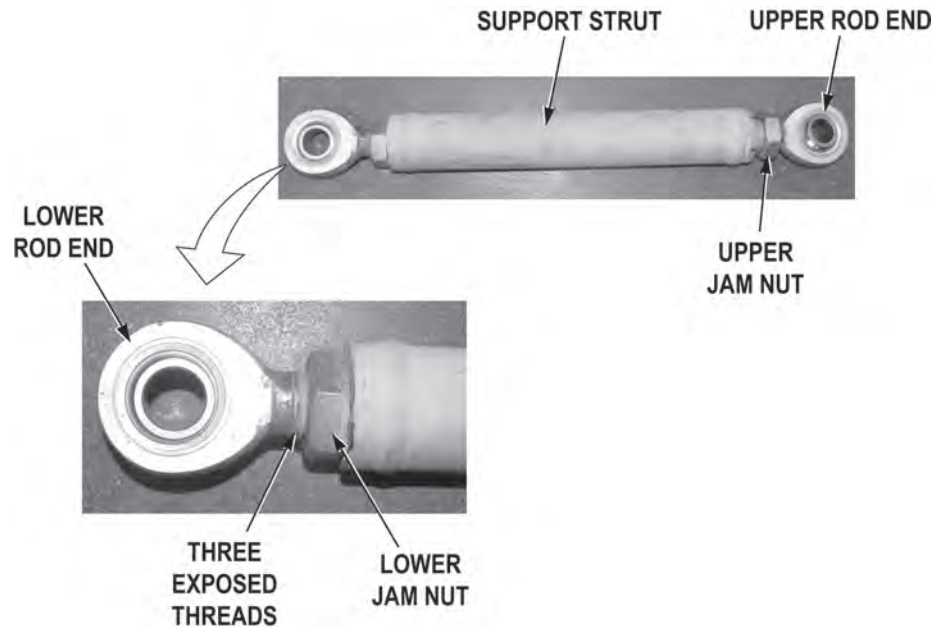

3. Adjust lower rod ends and lower jam nuts on support strut leaving three exposed threads as shown.

### WARNING

**SPARK bar weighs 97 lbs (44 kg). Do not lift or move SPARK bar without the aid of an assistant and lifting device. Failure to comply may result in injury or death to personnel.**

4. With the aid of an assistant and lifting device, install SPARK bar (12) on two frame extensions (13) with 12 screws (11) and new locknuts (10).

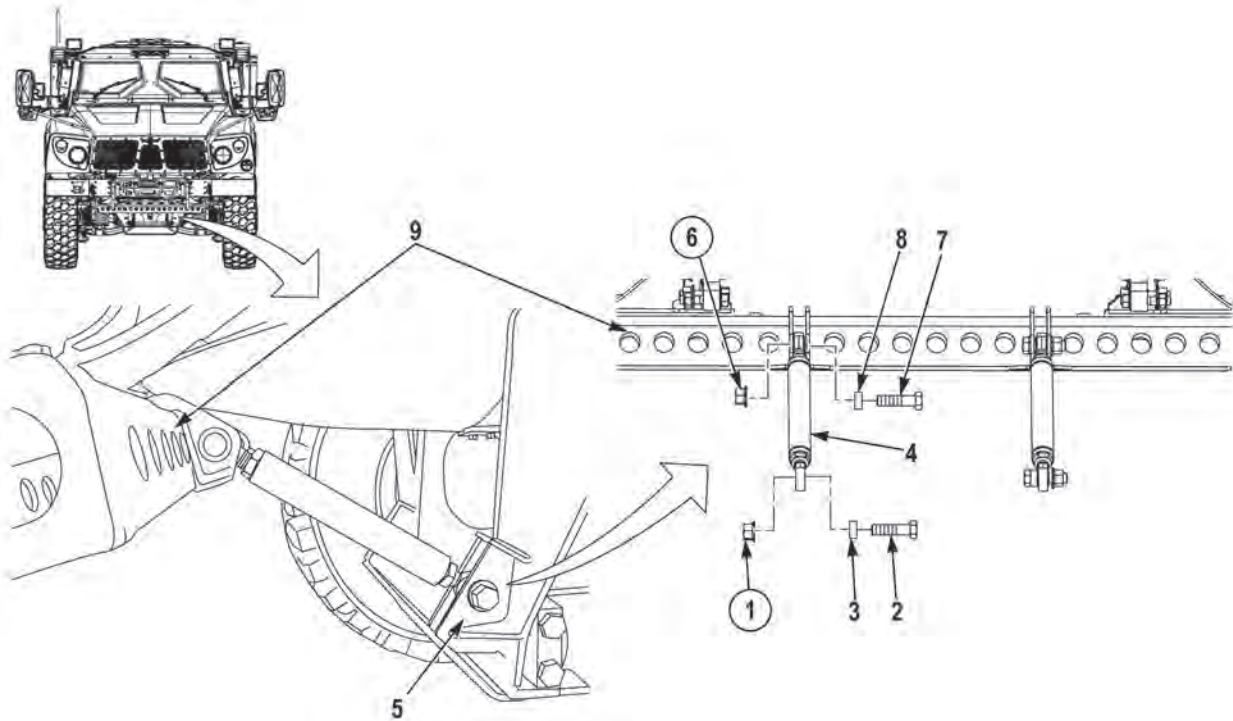

### NOTE

- Both support struts are installed the same way. Driver side shown.
- Install spacers as noted prior to removal.
- Adjust upper rod ends as required.

5. Install support strut (4) and spacer (3) on two side plate gussets (5) with screw (2) and new locknut (1).
6. Install support strut (4) and spacer (8) on SPARK bar (9) with screw (7) and new locknut (6).
7. Tighten upper and lower jam nuts.
8. Repeat Steps (5) through (7) for passenger side support strut.
9. Perform all Follow-On Maintenance tasks.

**END OF TASK**

**END OF WORK PACKAGE**

---

**AIR CLEANER ASSEMBLY REPLACEMENT (M1240/M1245)**

---

**Preconditions**

Park vehicle  
 Engine OFF  
 Wheels chocked

**Materials/Parts**

Lockwasher (Item 8)  
 Compound, Anti-Corrosion Spray, 2233850

**Tools and Special Tools**

Tool Kit, General Mechanic's: Automotive

**Follow-On Maintenance**

Remove and stow wheel chocks

---

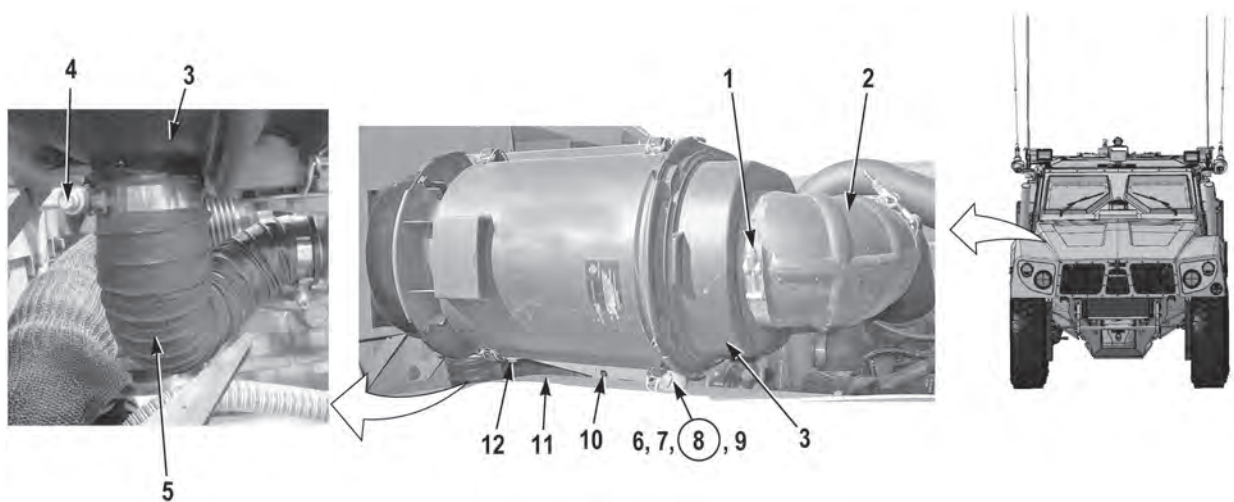
**REMOVAL**

1. Loosen and remove clamp (1) and hose (2) from air cleaner assembly (3).
2. Loosen and remove clamp (4) and hose (5) from air cleaner assembly (3).
3. Remove screw (6), washer (7), lockwasher (8), and spacer (9) from bracket (10) and engine panel (11). Discard lockwasher (8).
4. Remove three screws (12) and air cleaner assembly (3) from bracket (10).

**END OF TASK**

## INSTALLATION

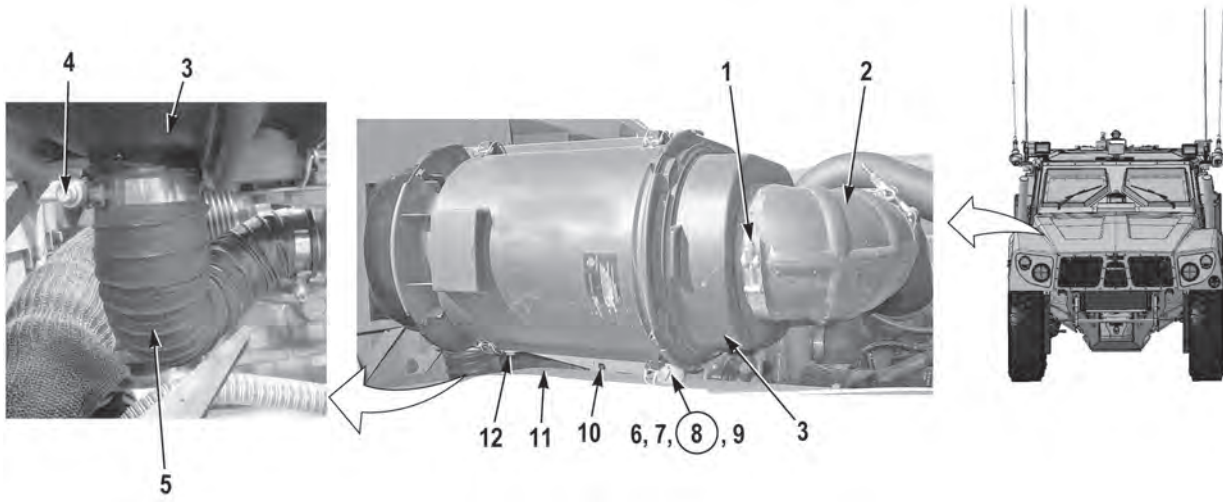

### **WARNING**

**Anti-corrosion compound is toxic. Use only in well-ventilated area. Use NIOSH/MSHA-approved respirator with dual organic vapor/mist and particulate cartridge. Do not get in eyes; wear chemical safety goggles and full face shield when using. Avoid contact with skin and wear rubber or plastic, solvent-resistant gloves. In case of contact, remove contaminated clothing and immediately wash area with soap and water. If eyes are contacted, flush eyes with large amounts of water for at least 15 minutes and get immediate medical attention. If swallowed, do not induce vomiting; contact a physician immediately. Failure to comply may result in injury or death to personnel.**

1. Apply anti-corrosion spray, 2233850, to mounting surface of bracket (10).
2. Install air cleaner assembly (3) on bracket (10) with three screws (12).
3. Install screw (6), washer (7), new lockwasher (8), and spacer (9) on bracket (10) and engine panel (11).
4. Install hose (5) on air cleaner assembly (3) with clamp (4).
5. Install hose (2) on air cleaner assembly (3) with clamp (1).
6. Perform all Follow-On Maintenance tasks.

**END OF TASK**

**END OF WORK PACKAGE**

---

**AIR CLEANER ASSEMBLY REPLACEMENT (M1240A1)**

---

**Preconditions**

Park vehicle  
 Engine OFF  
 Wheels chocked  
 Hood opened and secured  
 Passenger side radiator baffle removed  
 (WP 0181)

**Tools and Special Tools**

Adapter, 3/8 in. Female, 1/4 in. Male  
 Socket, 1/2 in. Deep, 3/8 in. Dr.  
 Tool Kit, General Mechanic's: Automotive  
 Wrench, Torque, 0 to 300 in-lb

**Materials/Parts**

Lockwasher (Item 2)  
 Lockwasher (Item 8)

**Follow-On Maintenance**

Install passenger side radiator baffle (WP 0181)  
 Close hood and secure  
 Remove and stow wheel chocks

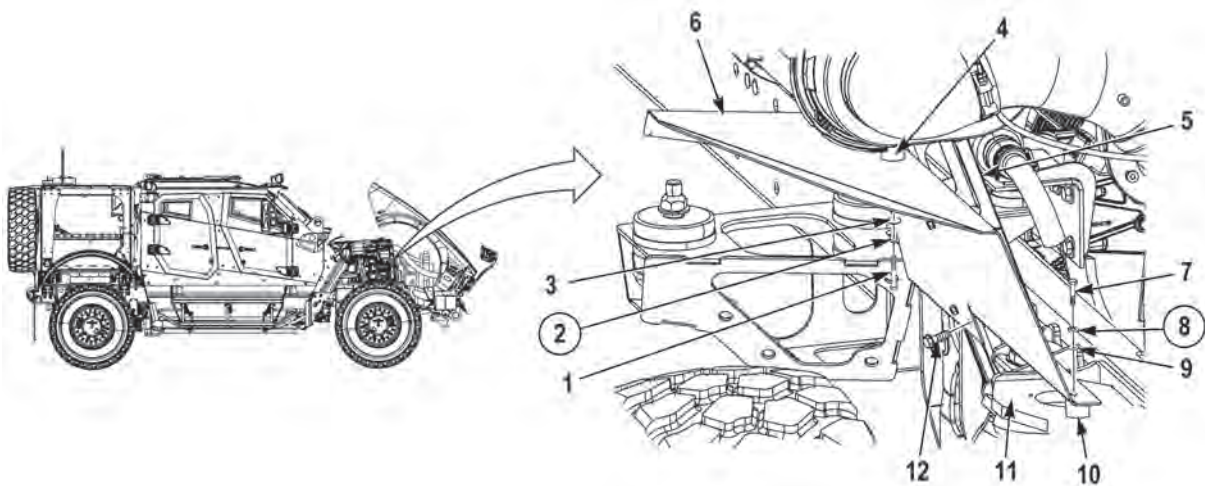
**PASSENGER SIDE ENGINE PANEL REMOVAL****NOTE**

Note position of spacers prior to removal to ensure proper installation.

1. Remove screw (1), lockwasher (2), washer (3), and small spacer (4) from bracket (5) and passenger side engine panel (6). Discard lockwasher (2).
2. Remove screw (7), lockwasher (8), washer (9), and large spacer (10) from side plate (11) and passenger side engine panel (6). Discard lockwasher (8).
3. Remove four screws (12) and passenger side engine panel (6) from bracket (5).

**END OF TASK**



## AIR CLEANER ASSEMBLY REMOVAL

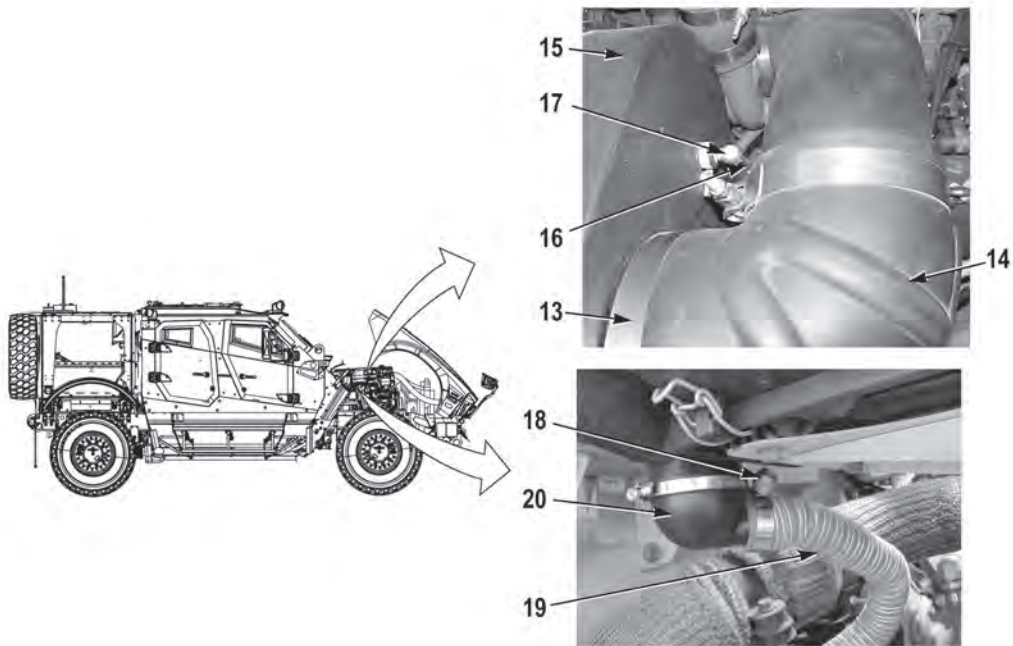

1. Loosen and remove clamp (13) and elbow (14) from air cleaner assembly (15).
2. Remove hose (16) from fitting (17).
3. Loosen and remove clamp (18) and hose (19) from check valve (20).

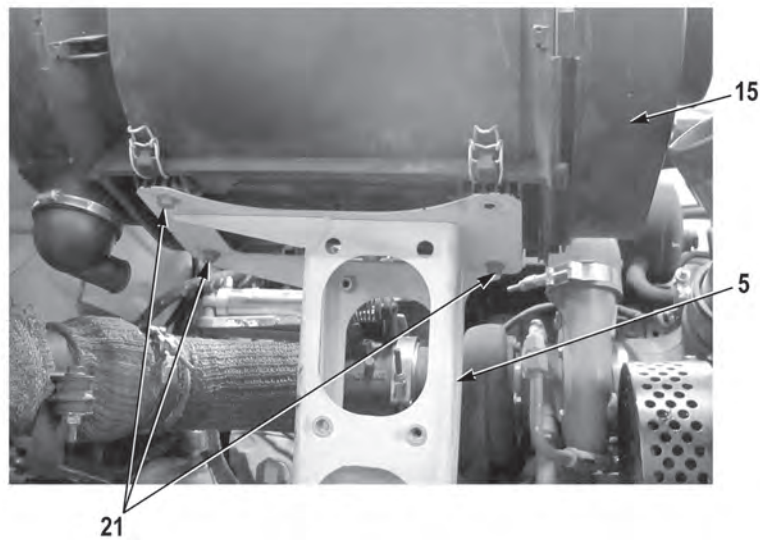

4. Remove three screws (21) and air cleaner assembly (15) from bracket (5).

**END OF TASK**



### AIR CLEANER ASSEMBLY INSTALLATION

1. Install air cleaner assembly (15) on bracket (5) with three screws (21).
2. Install hose (19) on check valve (20) with clamp (18). Tighten clamp (18) to 30 to 70 lb-in (3 to 8 N•m).
3. Install hose (16) on fitting (17).
4. Install elbow (14) on air cleaner assembly (15) with clamp (13).

### END OF TASK

### PASSENGER SIDE ENGINE PANEL INSTALLATION

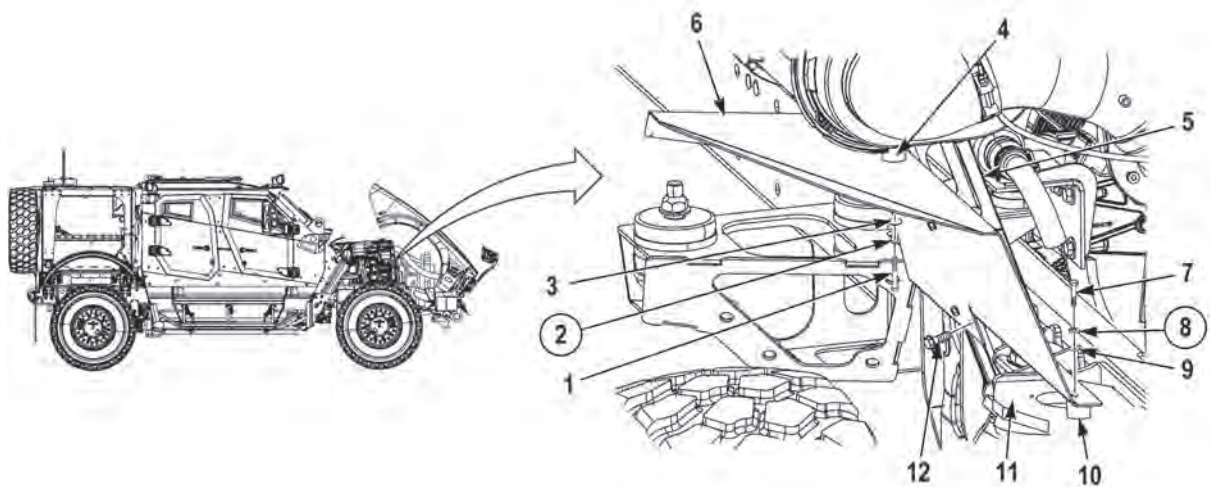

1. Install passenger side engine panel (6) on bracket (5) with four screws (12).

### NOTE

Install spacers as noted prior to removal.

2. Install passenger side engine panel (6) and large spacer (10) on side plate (11) with washer (9), new lockwasher (8), and screw (7).
3. Secure passenger side engine panel (6) and small spacer (4) on bracket (5) with washer (3), new lockwasher (2), and screw (1).
4. Perform all Follow-On Maintenance tasks.

### END OF TASK

### END OF WORK PACKAGE



---

**AIR FILTER REPLACEMENT**

---

**Preconditions**

Park vehicle  
Engine OFF  
Wheels chocked  
Hood opened and secured

**Materials/Parts**

None

**Follow-On Maintenance**

Close hood and secure  
Remove and stow wheel chocks

**Tools and Special Tools**

Tool Kit, General Mechanic's: Automotive

---

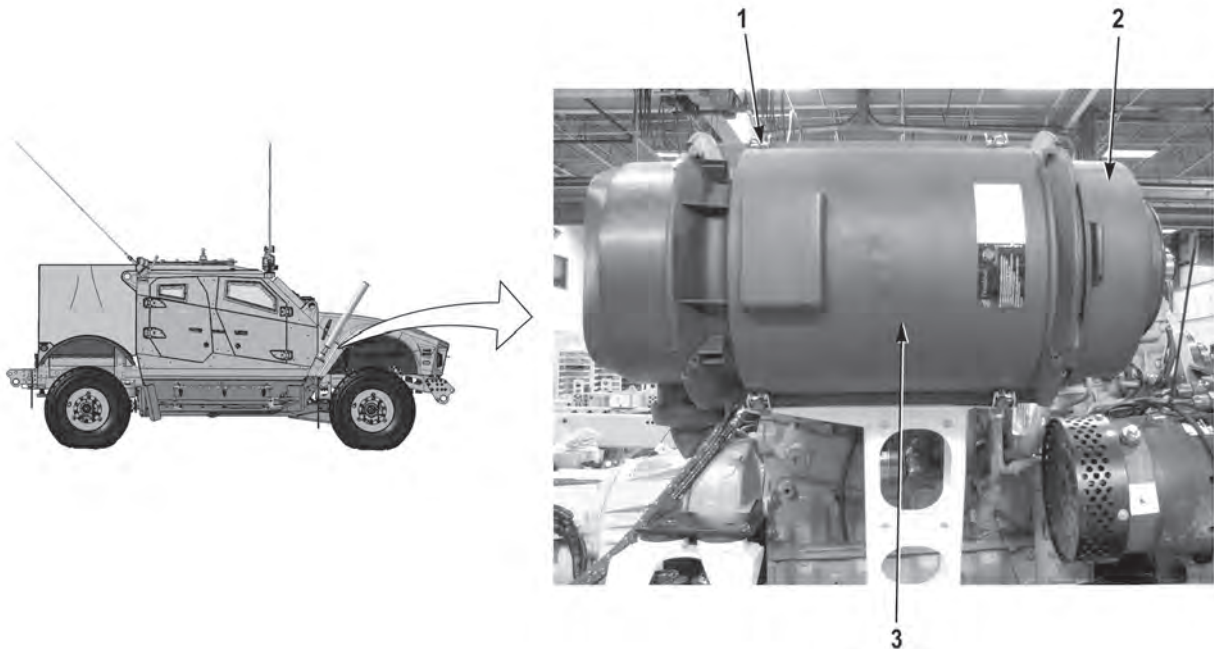
**REMOVAL****CAUTION**

**All air cleaner element maintenance must be performed above temperatures of -10°F (-23°C). Failure to comply may result in damage to equipment.**

1. Unlatch four latches (1) from air cleaner assembly (2) and cover (3).
2. Remove cover (3) from air cleaner assembly (2).



3. Remove air cleaner element (4) from air cleaner assembly (2).

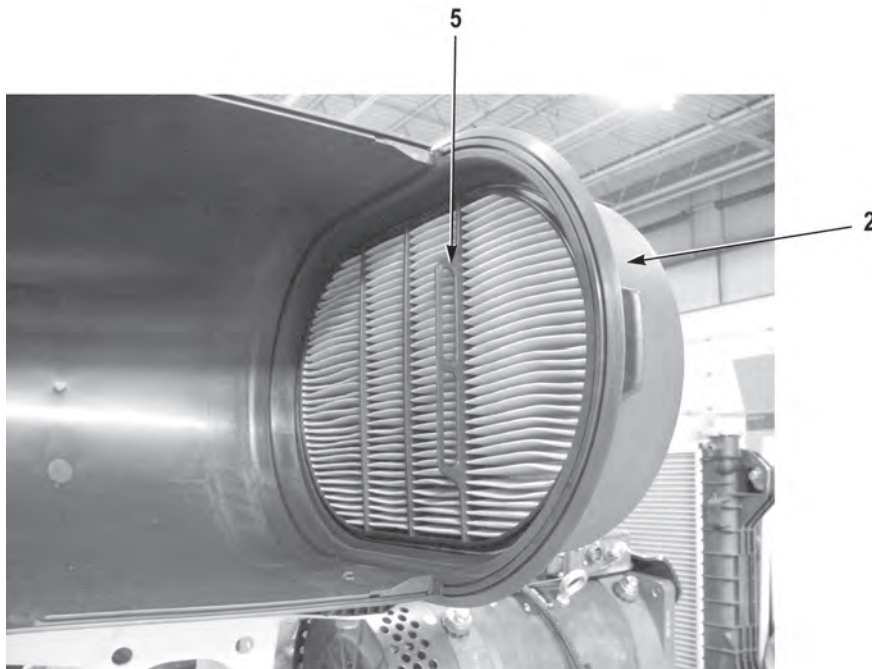

#### **NOTE**

Perform Step (4) for vehicles with two-piece air cleaner element.

4. Remove air cleaner element (5) from air cleaner assembly (2).

**END OF TASK**

**INSTALLATION****CAUTION**

All air cleaner element maintenance must be performed above temperatures of -10°F (-23°C). Failure to comply may result in damage to equipment.

**NOTE**

- Ensure air cleaner assembly is clean before installing air cleaner element.
  - Perform Step (1) for vehicles with two-piece air cleaner element.
1. Install air cleaner element (5) on air cleaner assembly (2).
  2. Install air cleaner element (4) on air cleaner assembly (2).

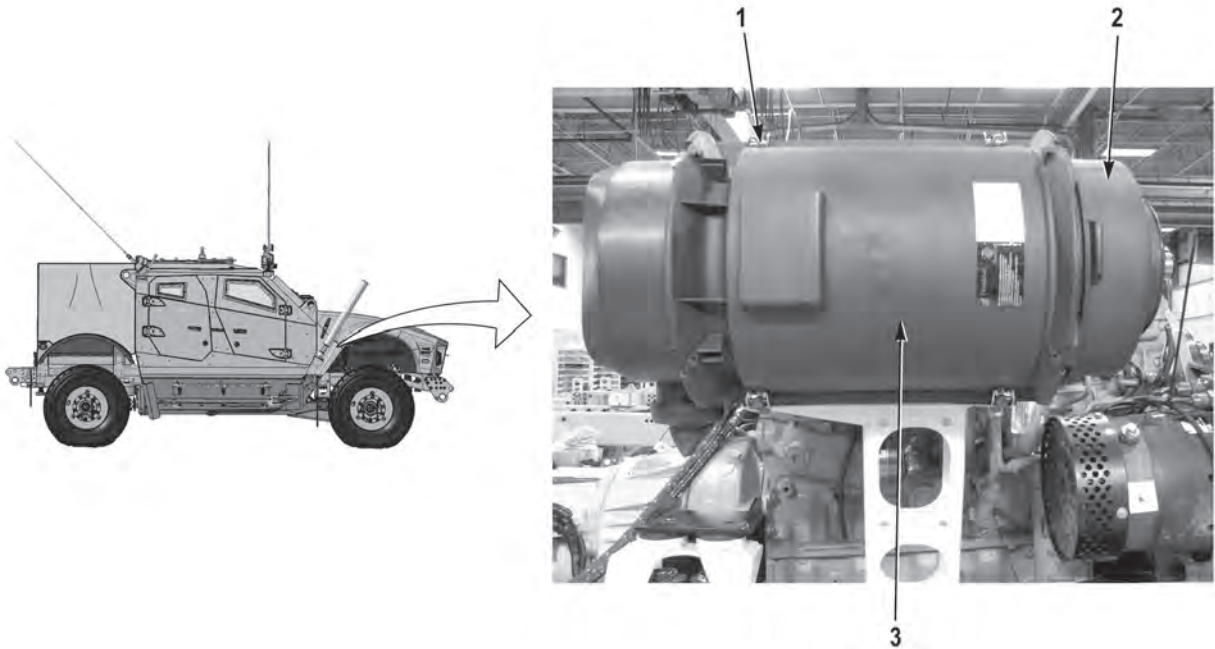

3. Install cover (3) on air cleaner assembly (2).
4. Latch four latches (1) on cover (3) and air cleaner assembly (2).
5. Perform all Follow-On Maintenance tasks.

**END OF TASK****END OF WORK PACKAGE**





---

**AIR INTAKE HOSES REPLACEMENT (M1240/M1245)**

---

**Preconditions**

Park vehicle  
Engine OFF  
Hood opened and secured  
Wheels chocked

**Tools and Special Tools**

Tool Kit, General Mechanic's: Automotive

**Materials/Parts**

Locknut (Item 29)  
Locknut (2) (Item 41)  
Compound, Anti-Corrosion Spray, 2233850

**Follow-On Maintenance**

Close hood and secure  
Remove and stow wheel chocks

---

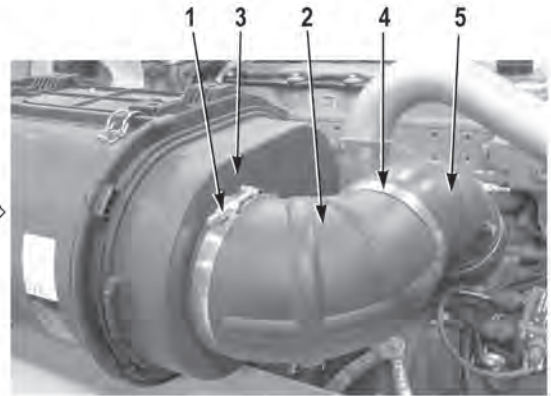
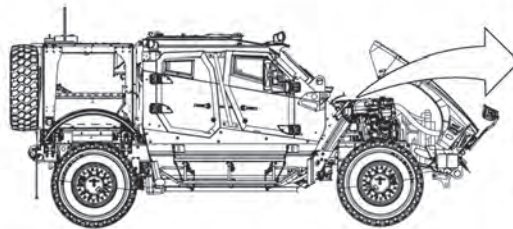
**REMOVAL****NOTE**

Note position of hoses prior to removal for proper installation.

1. Loosen clamp (1) and remove elbow (2) from air cleaner assembly (3).
2. Loosen clamp (4) and remove elbow (2) from pipe (5).

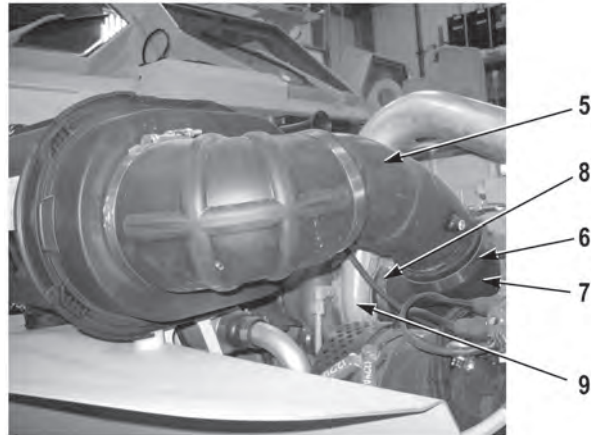

3. Loosen clamp (6) and remove pipe (5) from elbow (7).
4. Loosen clamp (8) and remove elbow (7) from turbocharger (9).

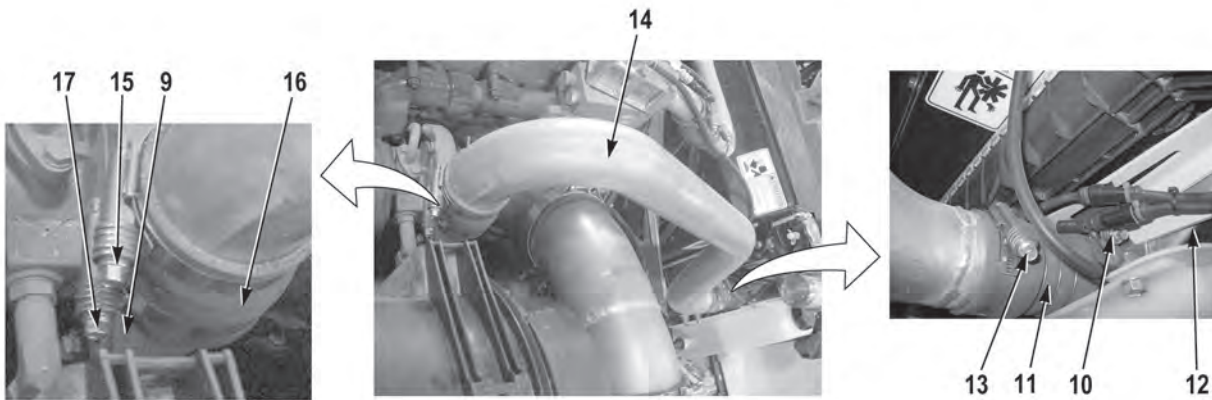

5. Loosen clamp (10) and remove hose (11) from charge air cooler (12).
6. Loosen clamp (13) and remove hose (11) from pipe (14).
7. Loosen clamp (15) and remove pipe (14) from hose (16).
8. Loosen clamp (17) and remove hose (16) from turbo charger (9).

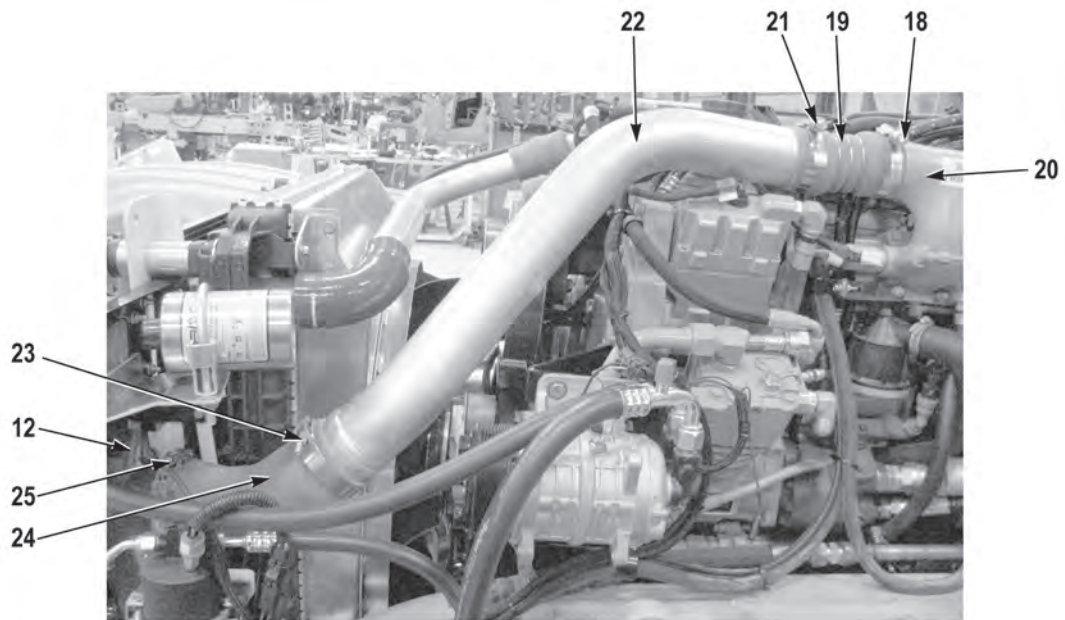

9. Loosen clamp (18) and remove hose (19) from engine (20).
10. Loosen clamp (21) and remove hose (19) from pipe (22).
11. Loosen clamp (23) and remove pipe (22) from elbow (24).
12. Loosen clamp (25) and remove elbow (24) from charge air cooler (12).

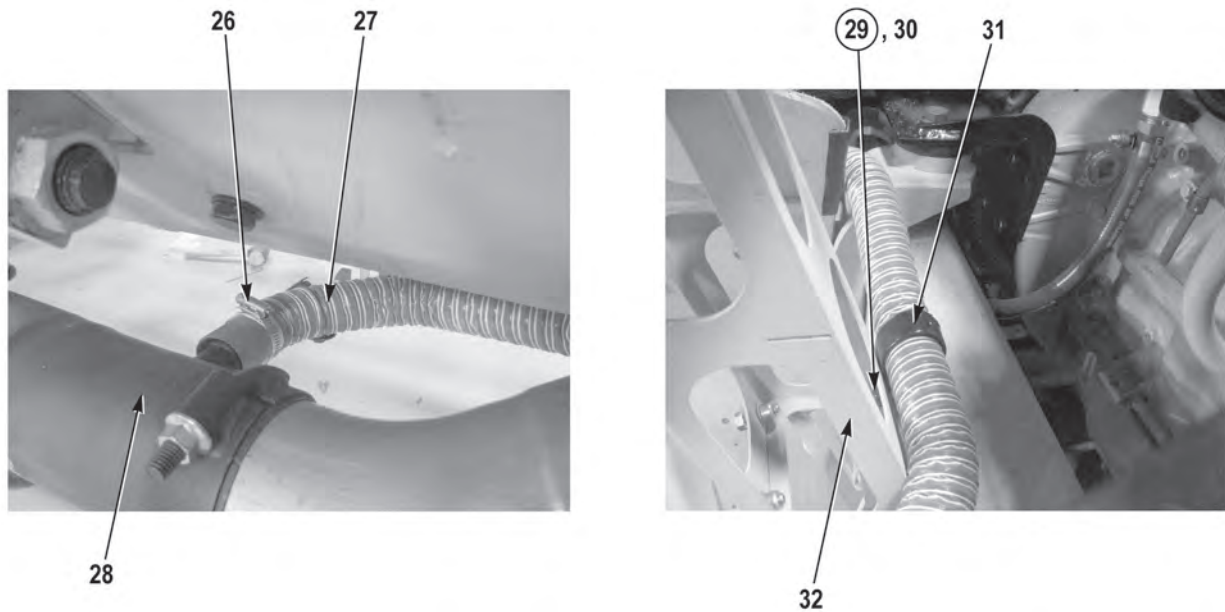

13. Loosen clamp (26) from hose (27) and remove hose (27) from muffler (28).
14. Remove locknut (29), screw (30), and cushion clip (31), from hose (27) and frame (32). Discard locknut (29).

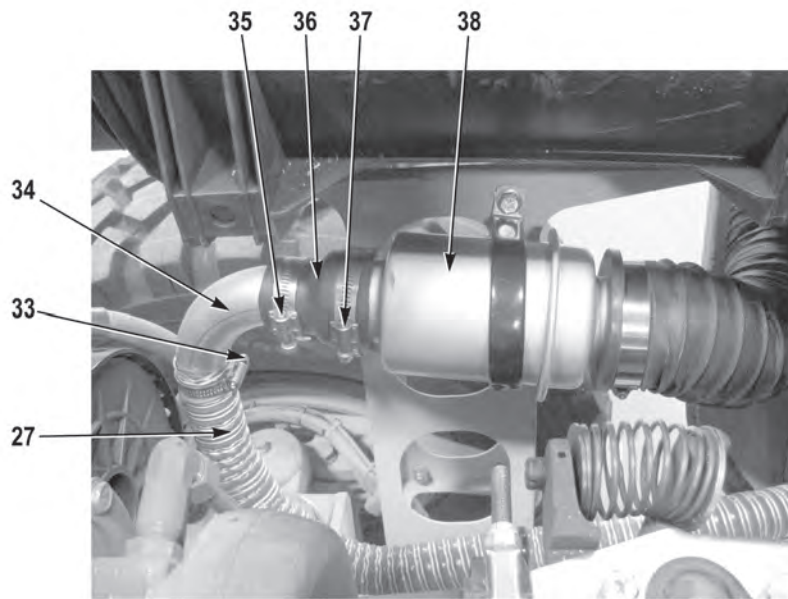

15. Loosen clamp (33) and remove hose (27) from pipe (34).
16. Loosen clamp (35) and remove pipe (34) from adapter (36).
17. Loosen clamp (37) and remove adapter (36) from canister (38).

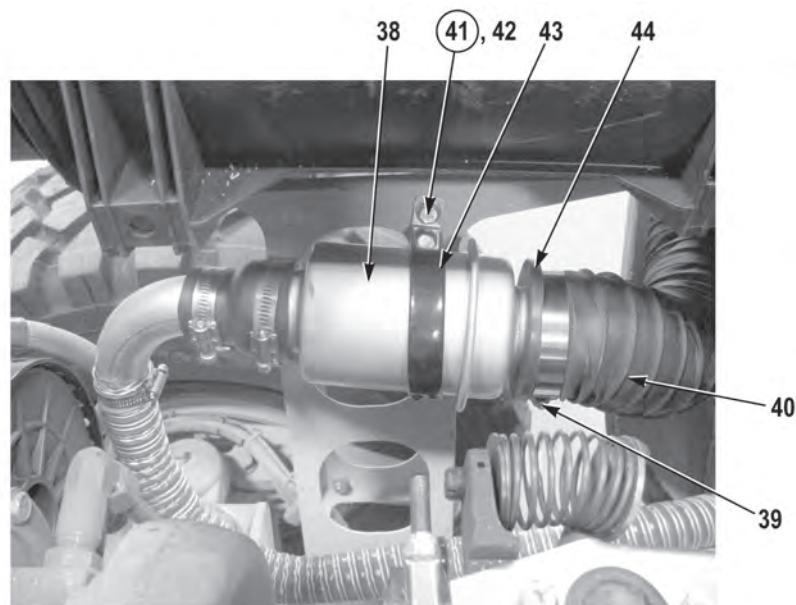

18. Loosen clamp (39) and remove hose (40) from canister (38).
19. Remove locknut (41), screw (42), cushion clip (43), and canister (38) from vehicle. Discard locknut (41).
20. Remove adapter (44) from canister (38).

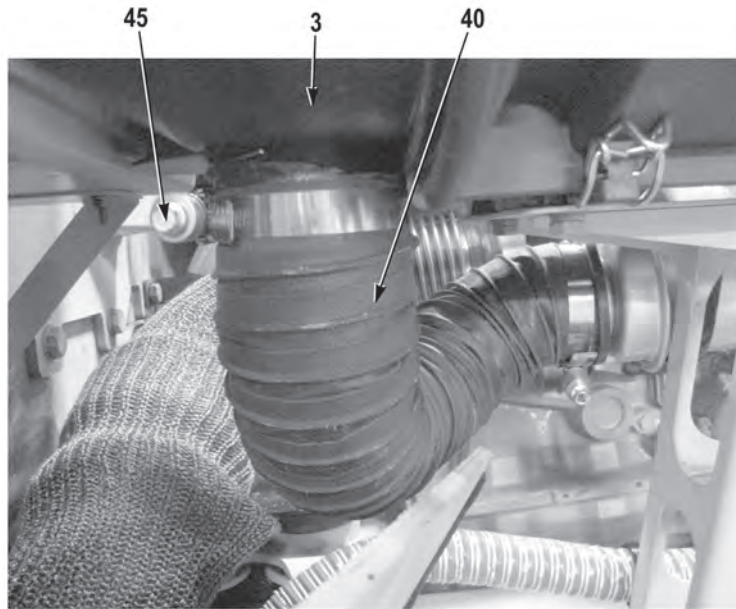

21. Loosen clamp (45) and remove hose (40) from air cleaner assembly (3).

#### **END OF TASK**

#### **INSTALLATION**

#### **NOTE**

Install hoses as noted prior to removal.

1. Install hose (40) on air cleaner assembly (3) with clamp (45).



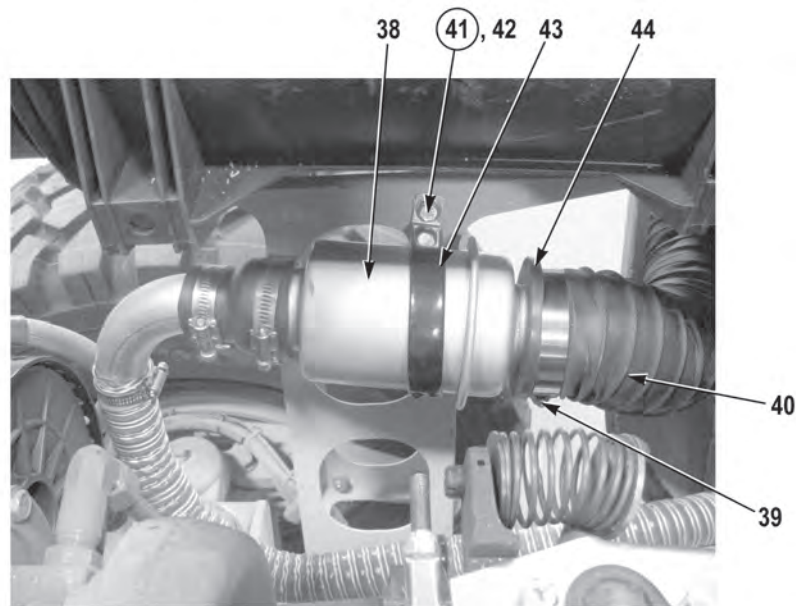

2. Install adapter (44) on canister (38).
3. Install canister (38) on vehicle with cushion clip (43), screw (42), and new locknut (41).

### **WARNING**

**Anti-corrosion compound is toxic. Use only in well-ventilated area. Use NIOSH/MSHA-approved respirator with dual organic vapor/mist and particulate cartridge. Do not get in eyes; wear chemical safety goggles and full face shield when using. Avoid contact with skin and wear rubber or plastic, solvent-resistant gloves. In case of contact, remove contaminated clothing and immediately wash area with soap and water. If eyes are contacted, flush eyes with large amounts of water for at least 15 minutes and get immediate medical attention. If swallowed, do not induce vomiting; contact a physician immediately. Failure to comply may result in injury or death to personnel.**

4. Apply anti-corrosion spray, Loctite 2233850, to cushion clip (43).
5. Install hose (40) on canister (38) with clamp (39).
6. Tighten two clamps (45 and 39) to 76 lb-in (9 N•m).



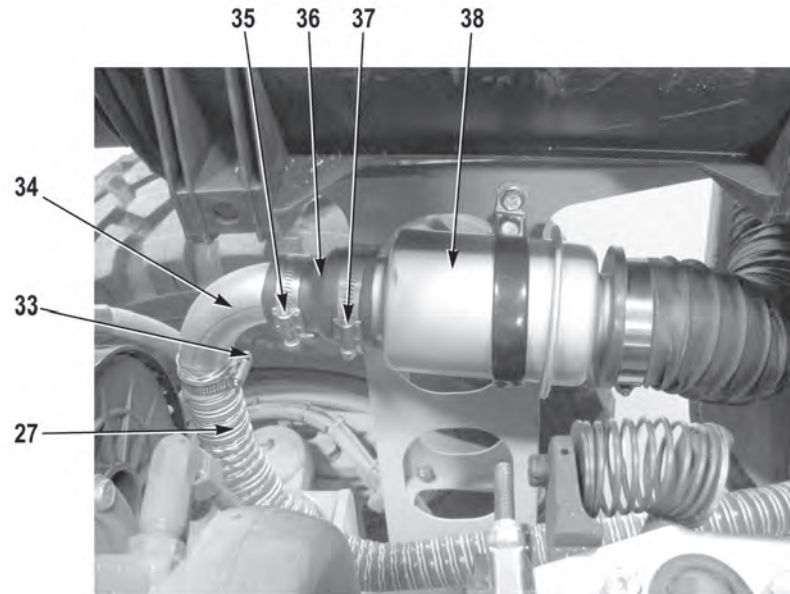

7. Install fitting (36) on canister (38) with clamp (37).
8. Install pipe (34) on adapter (36) with clamp (35).
9. Install hose (27) on pipe (34), with clamp (33).

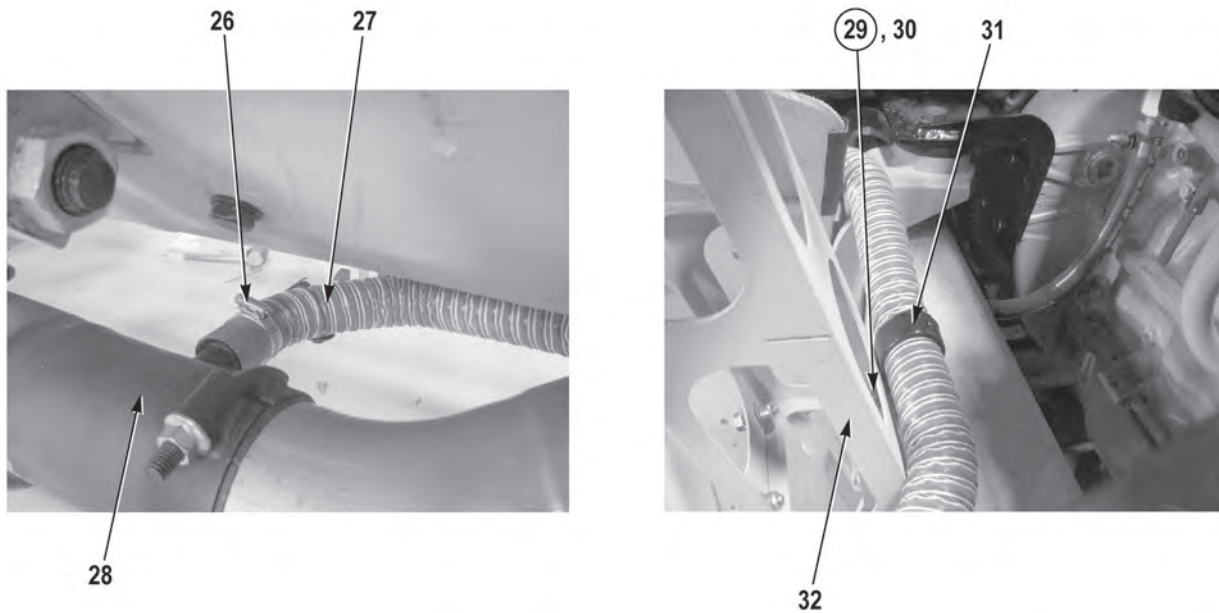

10. Install hose (27) on frame (32) with cushion clip (31), screw (30) and new locknut (29).

### **WARNING**

**Anti-corrosion compound is toxic. Use only in well-ventilated area. Use NIOSH/MSHA-approved respirator with dual organic vapor/mist and particulate cartridge. Do not get in eyes; wear chemical safety goggles and full face shield when using. Avoid contact with skin and wear rubber or plastic, solvent-resistant gloves. In case of contact, remove contaminated clothing and immediately wash area with soap and water. If eyes are contacted, flush eyes with large amounts of water for at least 15 minutes and get immediate medical attention. If swallowed, do not induce vomiting; contact a physician immediately. Failure to comply may result in injury or death to personnel.**

11. Apply anti-corrosion spray, Loctite 2233850, to cushion clip (31).
12. Install hose (27) on muffler (28) with clamp (26).

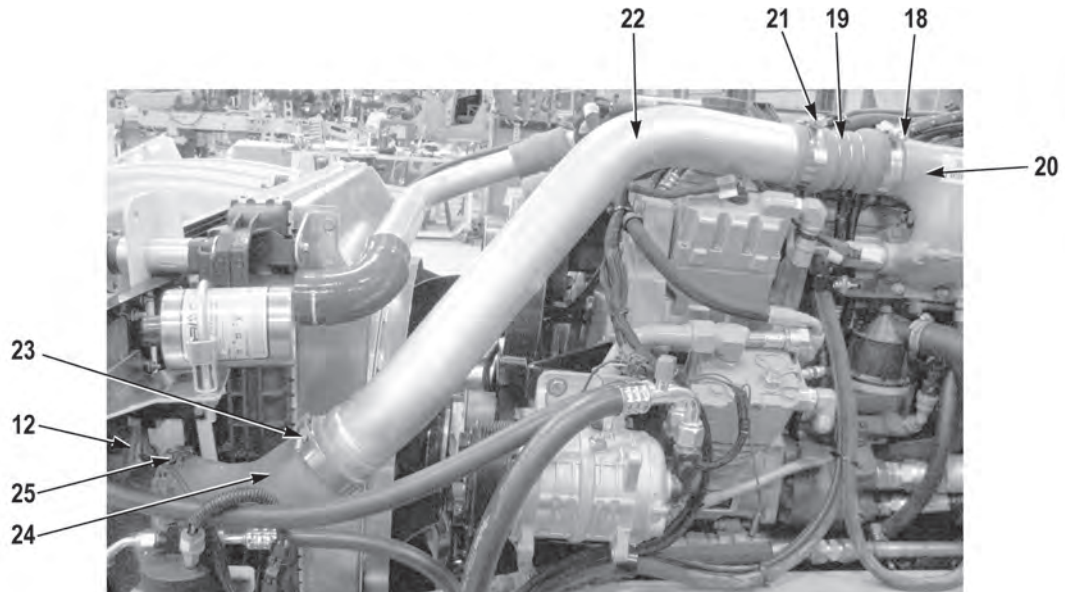
**NOTE**

Install cable ties as required.

13. Install elbow (24) on charge air cooler (12) with clamp (25).
14. Install pipe (22) on elbow (24) with clamp (23).
15. Install hose (19) on pipe (22) with clamp (21).
16. Install hose (19) on engine (20) with clamp (18).
17. Tighten four clamps (25, 23, 21, and 18) to 76 lb-in (9 N•m).

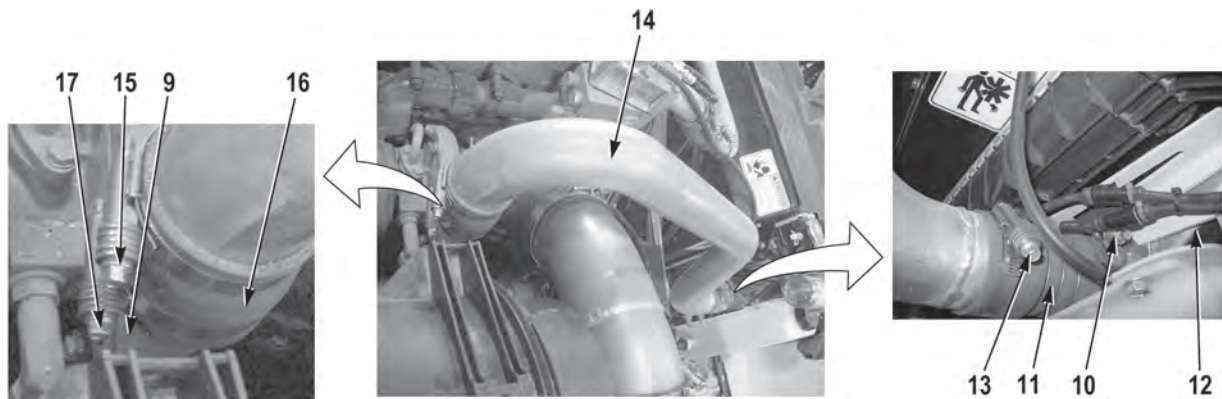

18. Install hose (16) on turbo charger (9) with clamp (17).
19. Install pipe (14) on hose (16) with clamp (15).
20. Install hose (11) on pipe (14) with clamp (13).
21. Install hose (11) on charge air cooler (12) with clamp (10).
22. Tighten four clamps (17, 15, 13, and 10) to 76 lb-in (9 N•m).

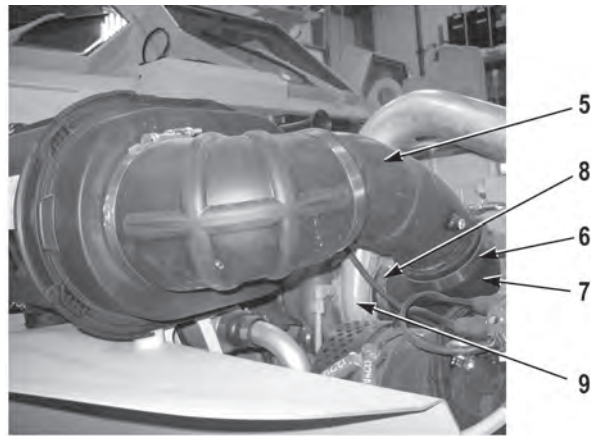

23. Install elbow (7) on turbo charger (9) with clamp (8).

24. Install pipe (5) on elbow (7) with clamp (6).

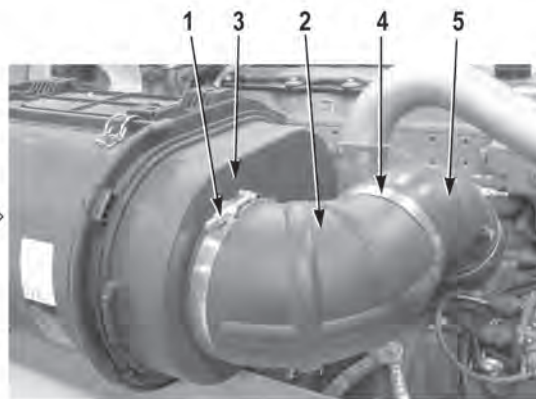
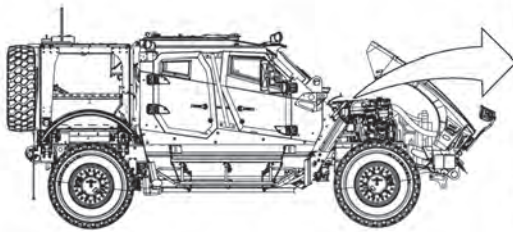

25. Install elbow (2) on pipe (5) with clamp (4).

26. Install elbow (2) on air cleaner assembly (3) with clamp (1).

27. Perform all Follow-On Maintenance tasks.

**END OF TASK**

**END OF WORK PACKAGE**

---

**AIR INTAKE HOSES REPLACEMENT (M1240A1)**

---

**Preconditions**

Park vehicle  
Engine OFF  
Wheels chocked  
Hood opened and secured  
Passenger side front wheel well deflector removed (WP 0057)

**Tools and Special Tools**

Socket, 3/8 in. Dr, 11 mm, Deep Well  
Tool Kit, General Mechanic's: Automotive  
Wrench, Torque, 0 to 300 in-lb

**Materials/Parts**

Ties, Cable

**Follow-On Maintenance**

Install passenger side front wheel well deflector (WP 0057)  
Close hood and secure  
Remove and stow wheel chocks

---

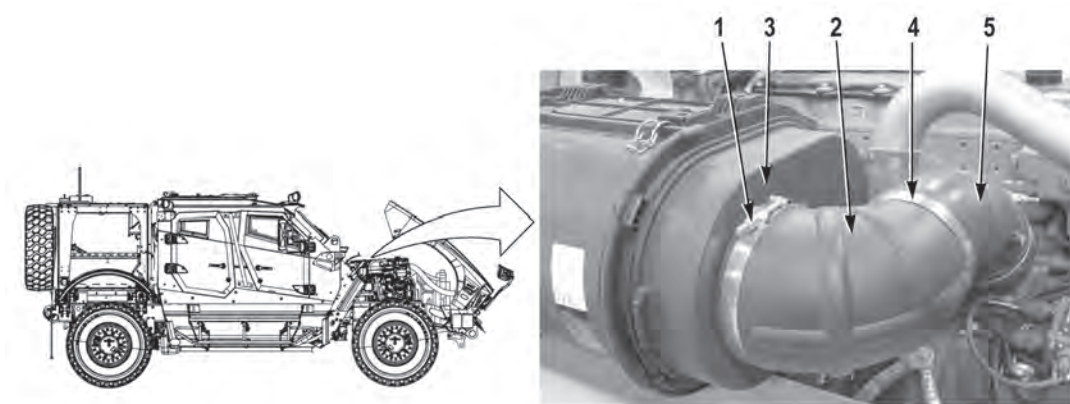
**REMOVAL****NOTE**

- Note position of hoses prior to removal for proper installation.
- Remove cable ties as required.

1. Loosen clamp (1) and remove elbow (2) from air cleaner assembly (3).
2. Loosen clamp (4) and remove elbow (2) from pipe (5).



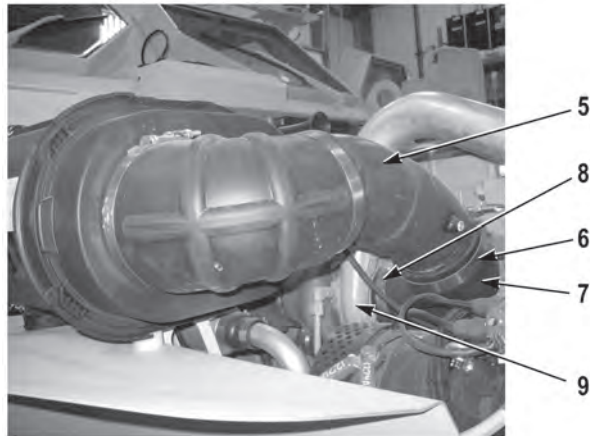

3. Loosen clamp (6) and remove pipe (5) from elbow (7).
4. Loosen clamp (8) and remove elbow (7) from turbocharger (9).

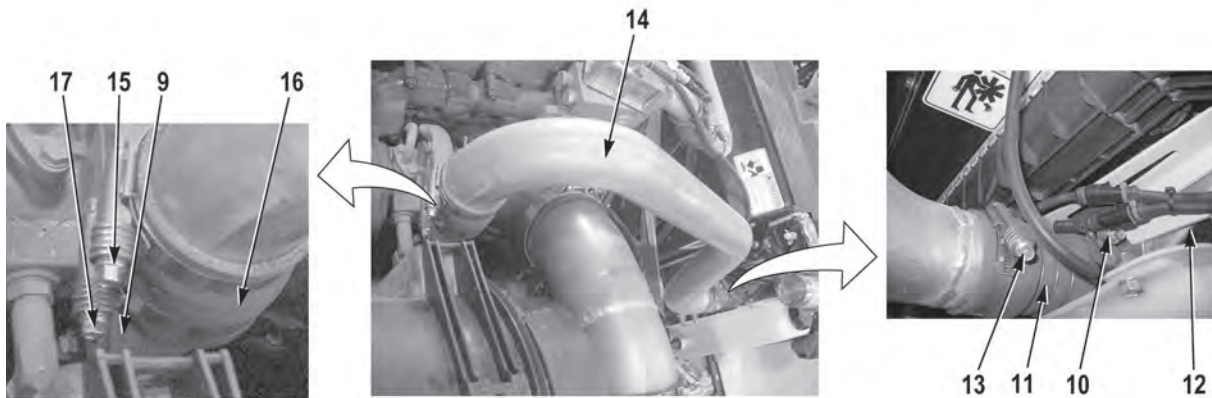

5. Loosen clamp (10) and remove hose (11) from charge air cooler (12).
6. Loosen clamp (13) and remove hose (11) from pipe (14).
7. Loosen clamp (15) and remove pipe (14) from hose (16).
8. Loosen clamp (17) and remove hose (16) from turbocharger (9).



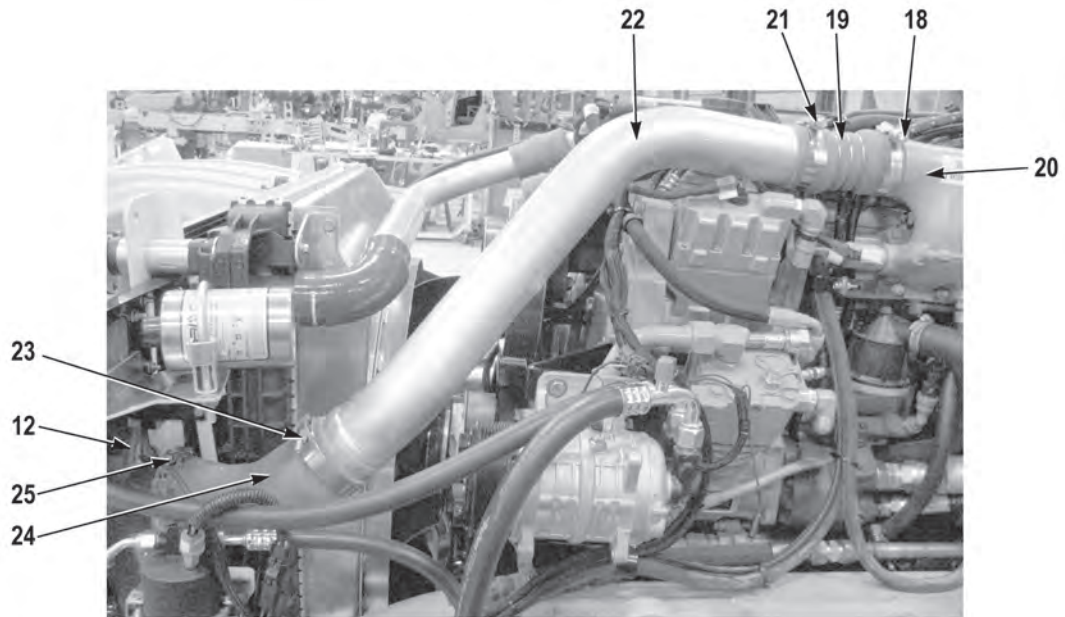

9. Loosen clamp (18) and remove hose (19) from engine (20).
10. Loosen clamp (21) and remove hose (19) from pipe (22).
11. Loosen clamp (23) and remove pipe (22) from elbow (24).
12. Loosen clamp (25) and remove elbow (24) from charge air cooler (12).

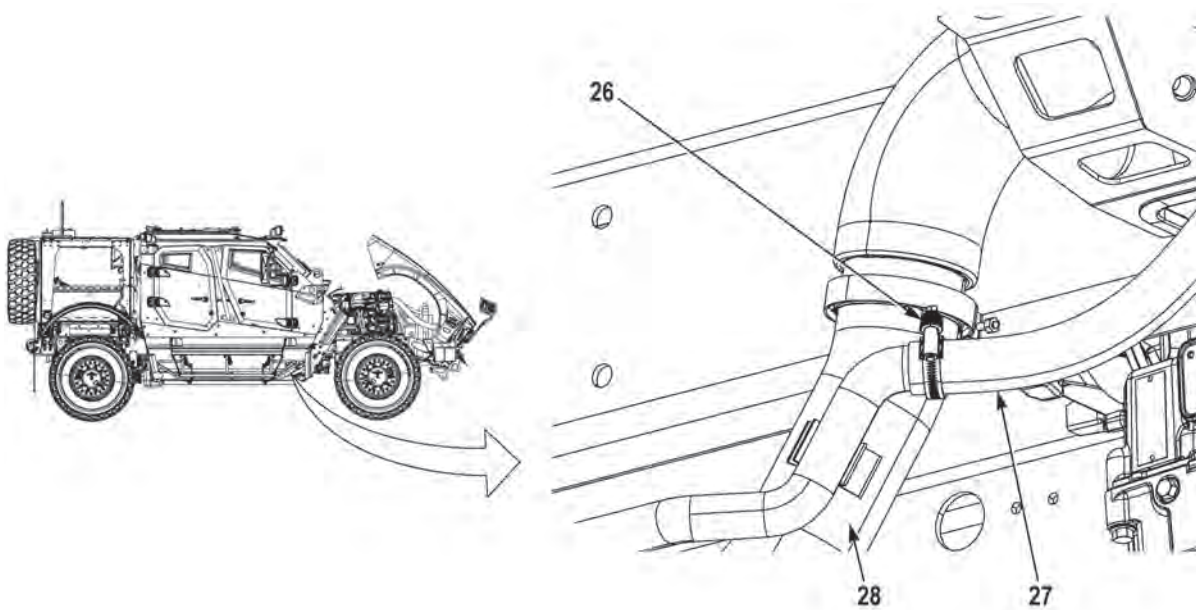

13. Loosen clamp (26) and remove hose (27) from muffler (28).

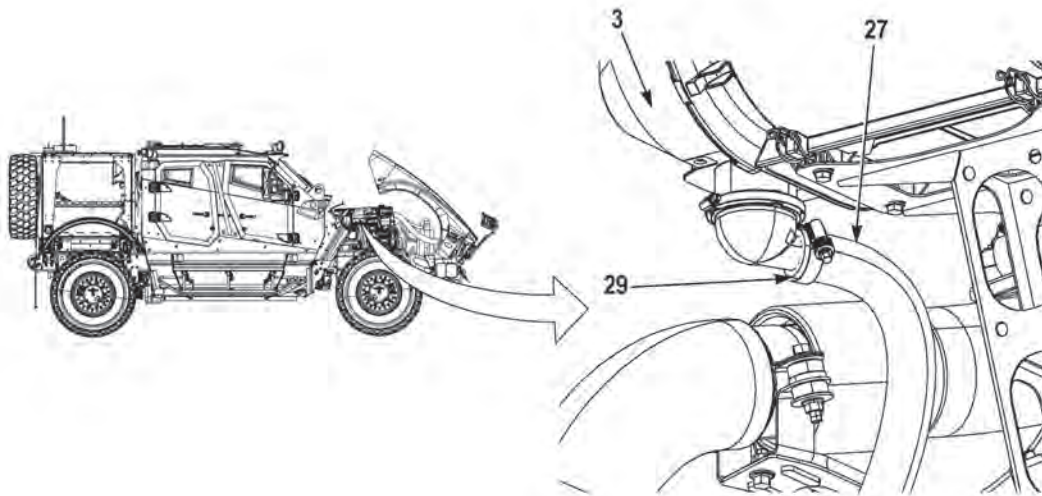

14. Loosen clamp (29) and remove hose (27) from air cleaner assembly (3).

#### END OF TASK

#### INSTALLATION

#### NOTE

- Install hoses as noted prior to removal.
- Install cable ties as required.

1. Install hose (27) on air cleaner assembly (3) with clamp (29).

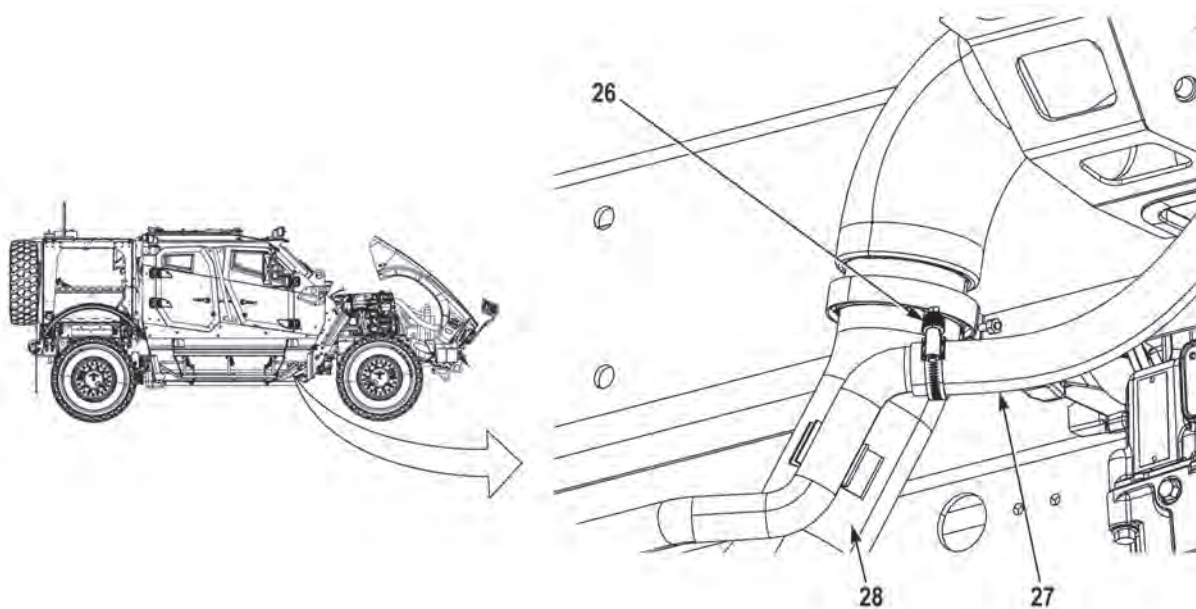

2. Install hose (27) on muffler (28) with clamp (26).

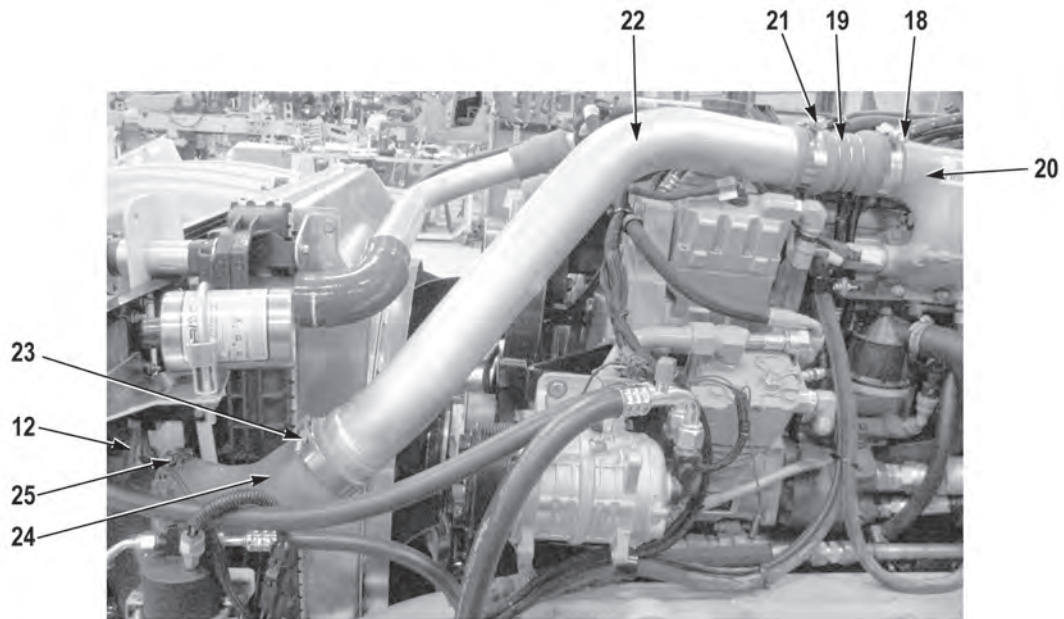

3. Install elbow (24) on charge air cooler (12) with clamp (25).
4. Install pipe (22) on elbow (24) with clamp (23).
5. Install hose (19) on pipe (22) with clamp (21).
6. Install hose (19) on engine (20) with clamp (18).
7. Tighten six clamps (29, 26, 25, 23, 21, and 18) to 76 lb-in (9 N•m).

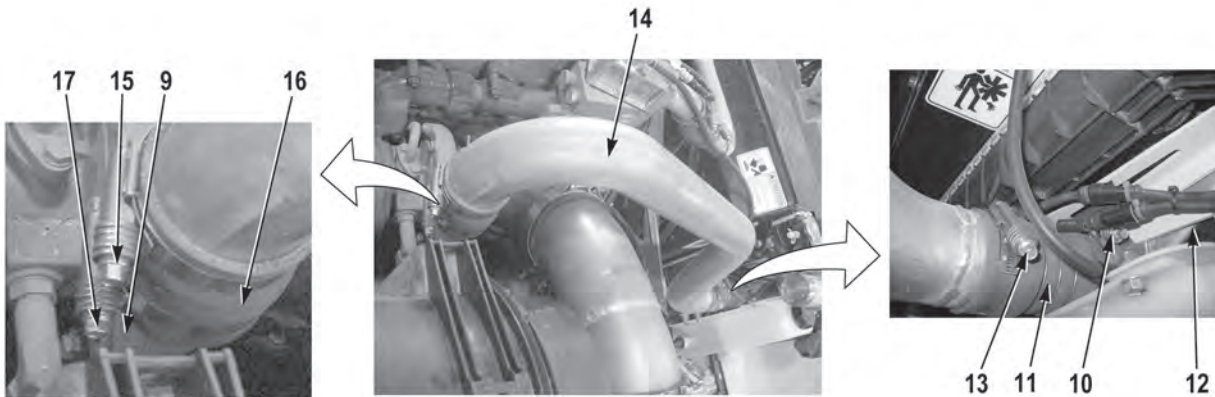

8. Install hose (16) on turbocharger (9) with clamp (17).
9. Install pipe (14) on hose (16) with clamp (15).
10. Install hose (11) on pipe (14) with clamp (13).
11. Install hose (11) on charge air cooler (12) with clamp (10).
12. Tighten four clamps (17, 15, 13, and 10) to 76 lb-in (9 N•m).

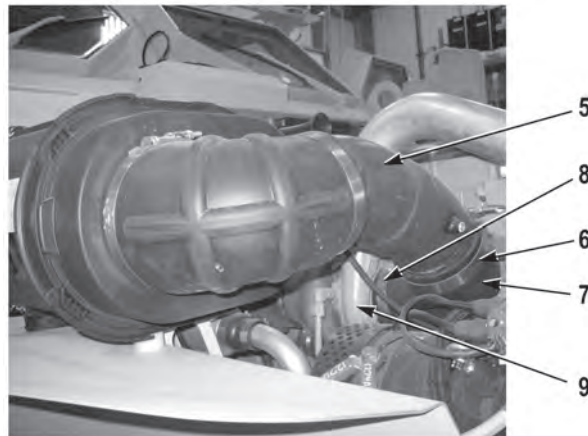

13. Install elbow (7) on turbocharger (9) with clamp (8).
14. Install pipe (5) on elbow (7) with clamp (6).



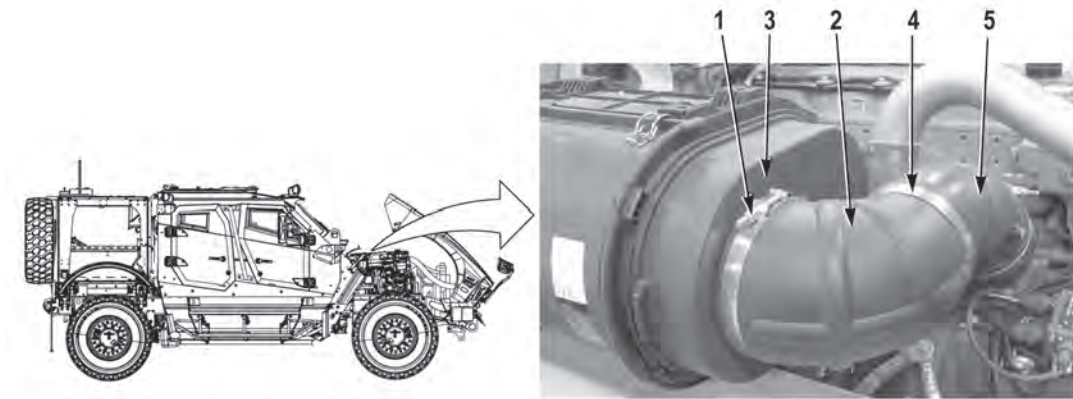

15. Install elbow (2) on pipe (5) with clamp (4).
16. Install elbow (2) on air cleaner assembly (3) with clamp (1).
17. Tighten two clamps (8 and 6) to 76 lb-in (9 N•m).
18. Perform all Follow-On Maintenance tasks.

**END OF TASK**

**END OF WORK PACKAGE**





---

**FUEL FILTER REPLACEMENT**

---

**Preconditions**

Park vehicle  
 Engine OFF  
 Wheels chocked  
 Hood opened and secured

**Tools and Special Tools**

Pan, Drain  
 Tool Kit, General Mechanic's: Automotive  
 Wrench, Oil Filter

**Materials/Parts**

Filter, Fuel (Item 1)  
 O-ring (Item 2)  
 Fuel, Diesel, ASTM D976

**Follow-On Maintenance**

Close hood and secure  
 Remove and stow wheel chocks

---

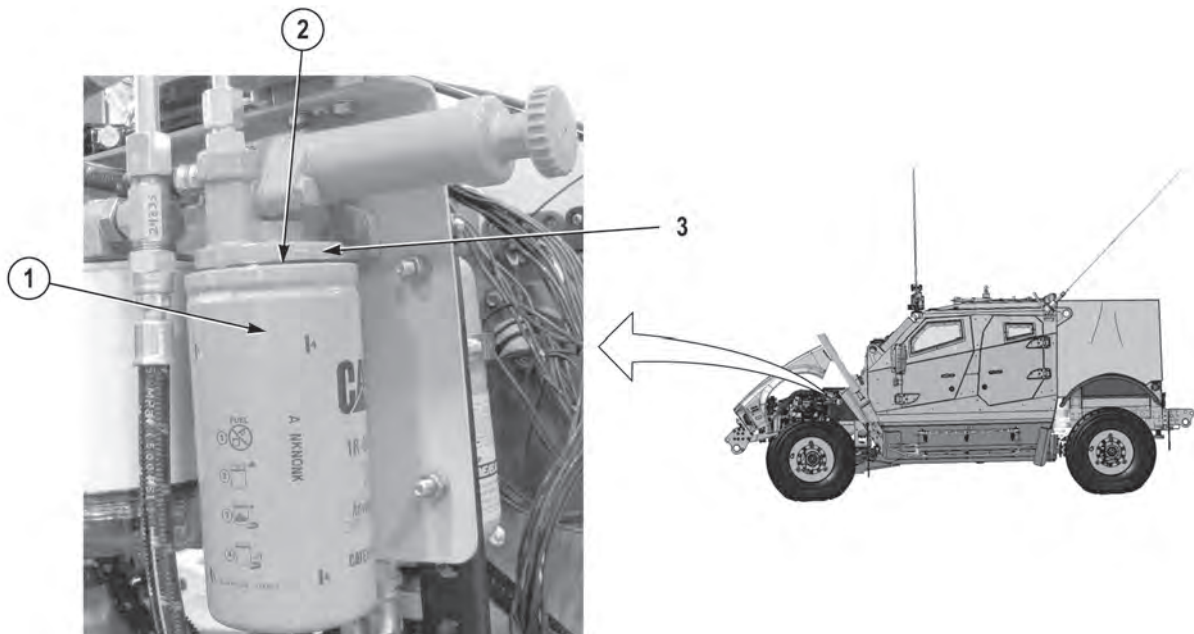
**REMOVAL**

1. Position a suitable drain pan under fuel filter (1).

**WARNING**

**Fuel is flammable and can explode. Keep fuel away from open flame and keep fire extinguisher within easy reach when working with fuel. Do not work on fuel system when engine is hot. Fuel can be ignited by hot engine. Smoking is prohibited while working with fuel. Failure to comply may result in injury or death to personnel.**

**NOTE**

When removing fuel filter, turn filter counterclockwise when viewed from bottom of filter.

2. Remove fuel filter (1) and O-ring (2) from housing (3). Discard fuel filter (1) and O-ring (2).

**END OF TASK**

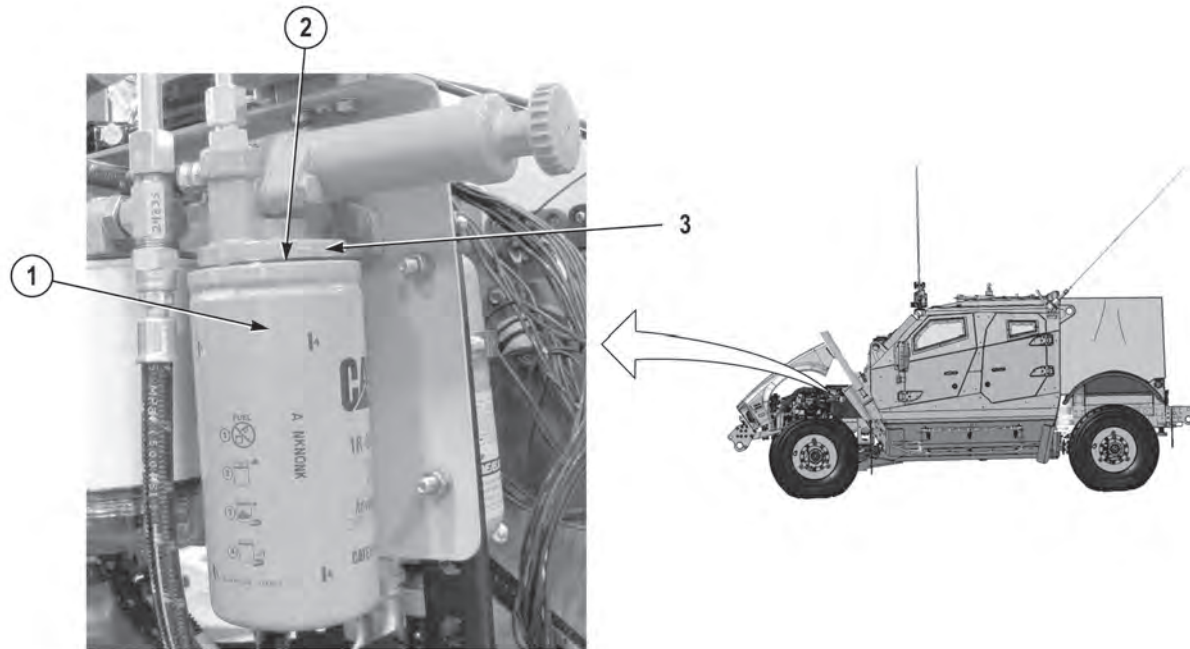
**INSTALLATION****WARNING**

Fuel is flammable and can explode. Keep fuel away from open flame and keep fire extinguisher within easy reach when working with fuel. Do not work on fuel system when engine is hot. Fuel can be ignited by hot engine. Smoking is prohibited while working with fuel. Failure to comply may result in injury or death to personnel.

**CAUTION**

Fill fuel filter with clean fuel before installing. Failure to comply may result in damage to equipment.

1. Lightly lubricate new O-ring (2) with clean diesel fuel, ASTM D976, and install O-ring (2) on filter (1)

**CAUTION**

Do not use wrench to tighten fuel filter. Failure to comply may result in damage to equipment.

2. Install new fuel filter (1) and O-ring (2) on housing (3) until O-ring (2) contacts housing (3), then tighten 3/4 turn more by hand.
3. Perform all Follow-On Maintenance tasks.

**END OF TASK**

**END OF WORK PACKAGE**

---

**FUEL LINES REPLACEMENT**

---

**Preconditions**

Park vehicle  
 Engine OFF  
 Wheels chocked

**Materials/Parts**

Cap and Plug Set  
 Tags, Identification  
 Ties, Cable

**Tools and Special Tools**

Pan, Drain  
 Tool Kit, General Mechanic's: Automotive

**Follow-On Maintenance**

Prime fuel system  
 Remove and stow wheel chocks

---

**REMOVAL****WARNING**

**Fuel is flammable and can explode. Keep fuel away from open flame and keep fire extinguisher within easy reach when working with fuel. Do not work on fuel system when engine is hot. Fuel can be ignited by hot engine. Smoking is prohibited while working with fuel. Failure to comply may result in injury or death to personnel.**

**NOTE**

- When removing hoses, use drain pan to catch excess fuel.
- Remove and install cushion clips and cable ties as required.
- Tag and mark hoses prior to removal to ensure proper installation.
- Cap and plug hoses upon removal.

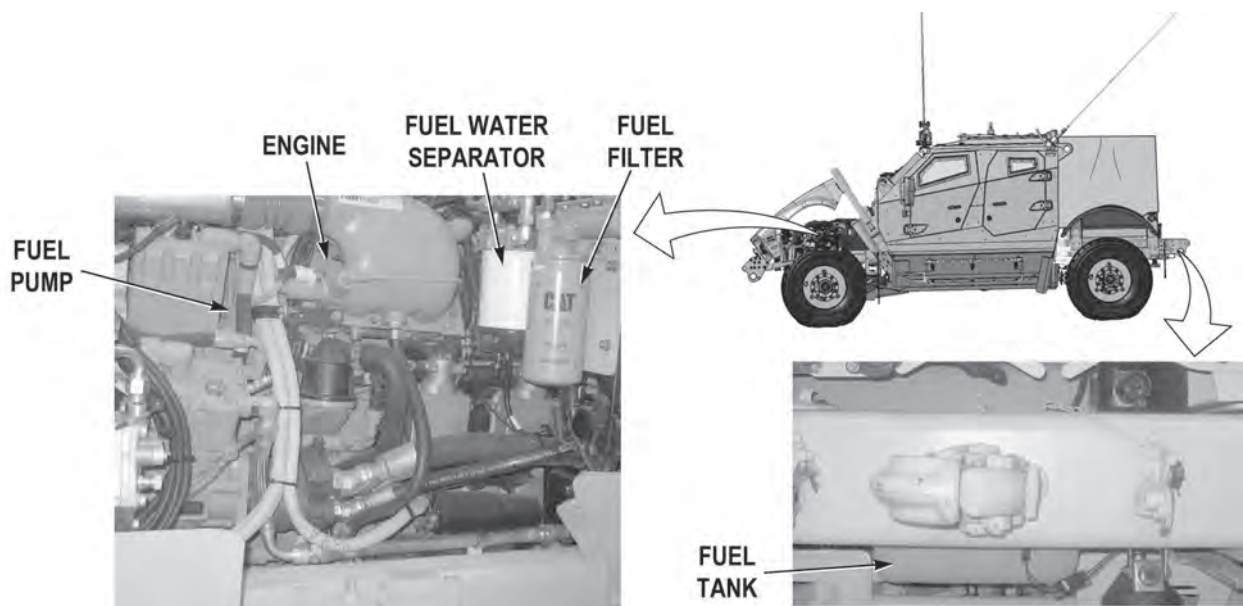

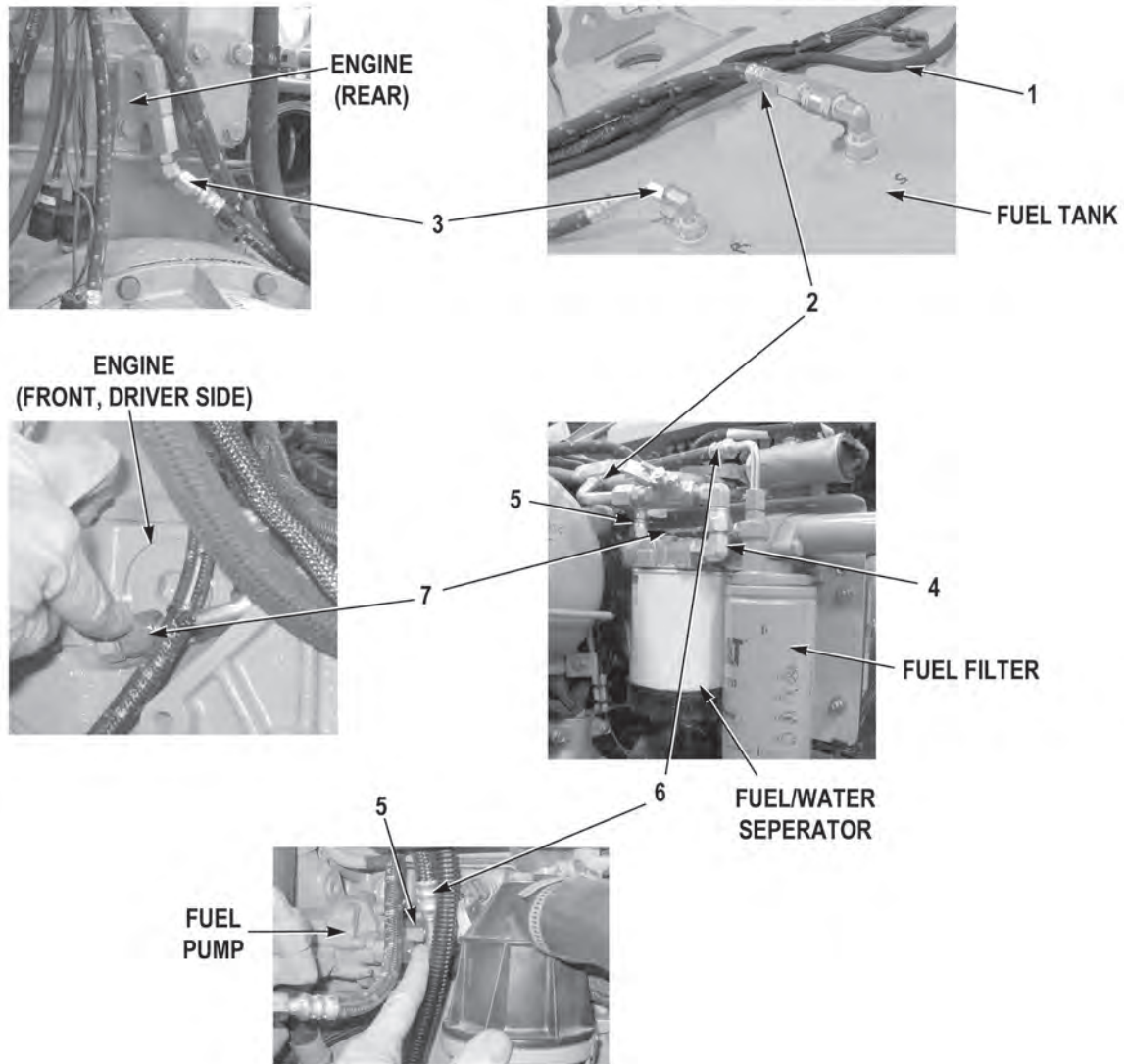

**Table 1. Fuel Line Routing.**

Fuel Line Number	From	To
1	Fuel Tank	Vent
2	Fuel Tank (Supply)	Fuel/Water Separator
3	Fuel Tank (Return)	Engine (Rear)
4	Fuel/Water Separator	Fuel Cut Off
5	Fuel/Water Separator	Fuel Pump
6	Fuel Pump	Fuel Filter
7	Fuel Filter	Engine (Front, Driver Side)

**END OF TASK**

**INSTALLATION****NOTE**

Install cushion clips and cable ties as required.

1. Perform all Follow-On Maintenance tasks.

**END OF TASK****END OF WORK PACKAGE**





---

**FUEL TANK REPLACEMENT**

---

**Preconditions**

Park vehicle  
Engine OFF  
Wheels chocked  
Cargo deck removed (M1240/M1240A1)  
(WP 0244)  
Cargo deck removed (M1245) (WP 0243)

**Tools and Special Tools**

Fuel Dispensing Pump  
Lifting Device  
Tool Kit, General Mechanic's: Automotive

**Materials/Parts**

Locknut (Item 11)  
Gasket (Item 22)  
Locknut (4) (Item 23)

**Materials/Parts (continued)**

Cap and Plug Set  
Compound, Sealing, Loctite 592  
Tags, Identification  
Ties, Cable

**Personnel Required**

Two

**Follow-On Maintenance**

Install cargo deck (M1240/M1240A1) (WP 0244)  
Install cargo deck (M1245) (WP 0243)  
Fill fuel tank  
Prime fuel system  
Remove and stow wheel chocks

---

**REMOVAL****WARNING**

**Fuel is flammable and can explode. Keep fuel away from open flame and keep fire extinguisher within easy reach when working with fuel. Do not work on fuel system when engine is hot. Fuel can be ignited by hot engine. Smoking is prohibited while working with fuel. Failure to comply may result in injury or death to personnel.**

**NOTE**

Remove cable ties as required.

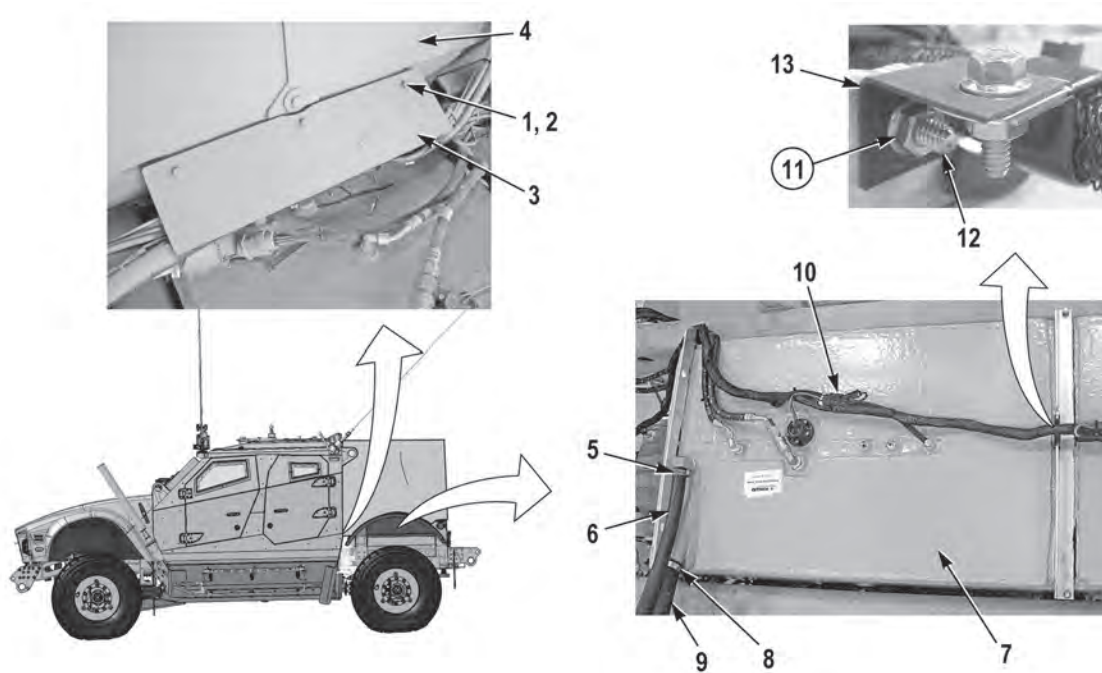

1. Remove three nuts (1), screws (2), and plate (3) from capsule (4).
2. Remove hose clamp (5) and fuel tank vent hose (6) from fuel tank (7).
3. Remove hose clamp (8) and filler hose (9) from fuel tank (7).
4. With the aid of a fuel dispensing pump, drain fuel tank (7).
5. Disconnect connector (10).
6. Remove locknut (11), screw (12), and bracket (13) from fuel tank (7). Discard locknut (11).

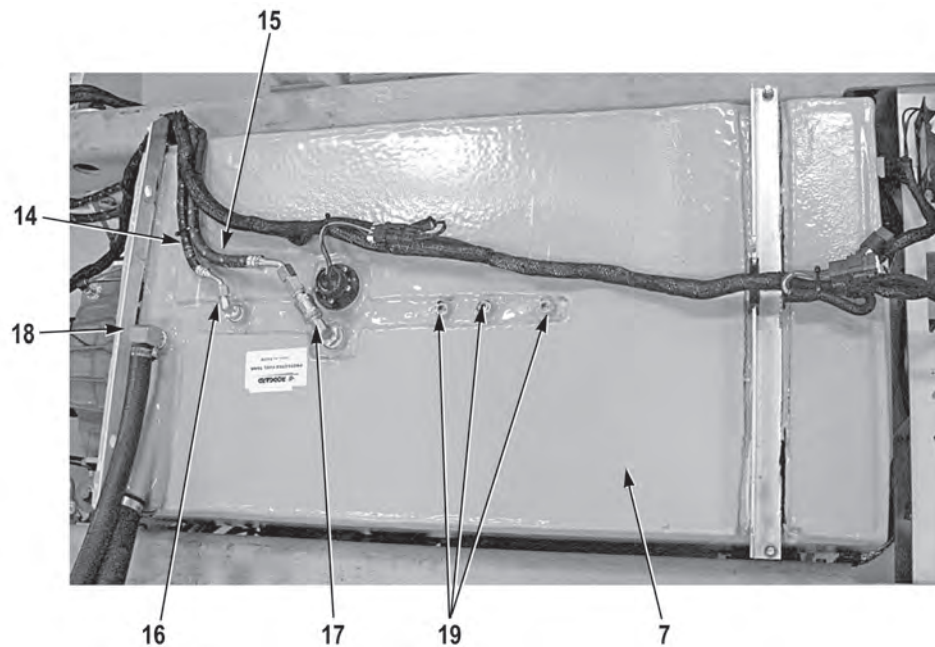
**NOTE**

- Tag and mark hoses prior to removal to ensure proper installation.
- Cap and plug hoses upon removal.

7. Remove two hoses (14 and 15) from fittings (16 and 17).

**NOTE**

Note position and location of fittings prior to removal to ensure proper installation.

8. Remove two fittings (16, 17, and 18) from fuel tank (7).
9. Remove three pipe plugs (19) from fuel tank (7).

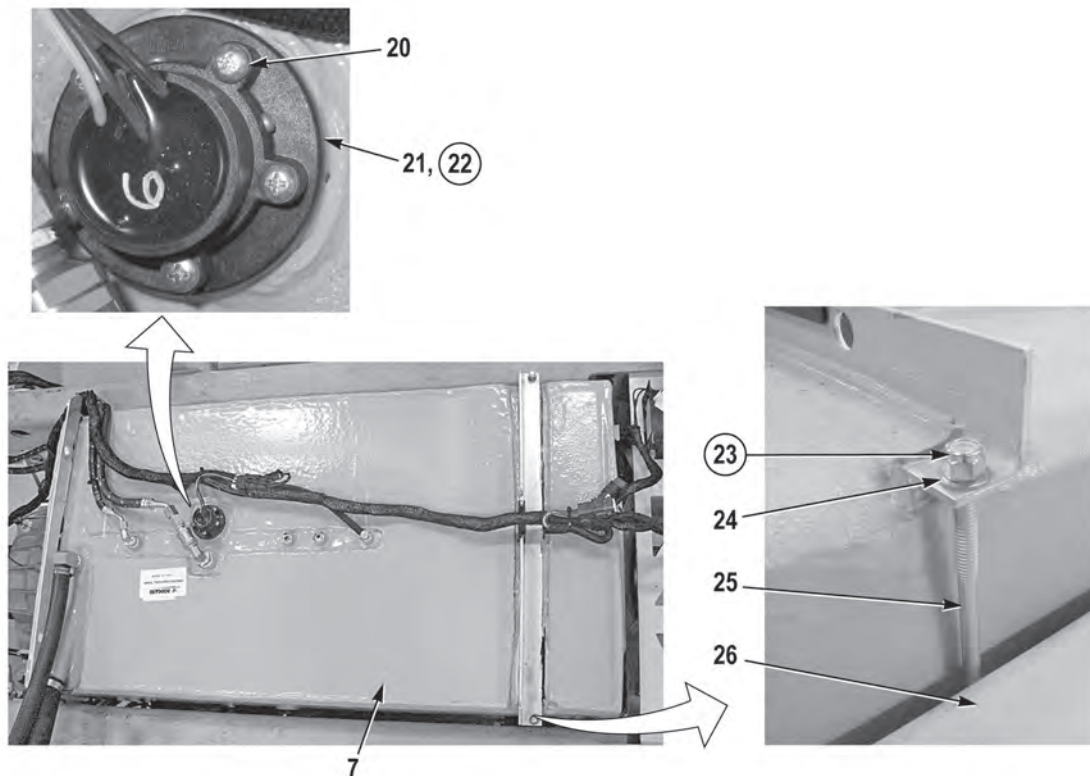

### NOTE

Note position of fuel level sensor prior to removal to ensure proper installation.

10. Remove five screws (20), fuel level sensor (21), and gasket (22) from fuel tank (7). Discard gasket (22).

### NOTE

There are four anchor locations that secure fuel tank to vehicle frame. All anchors are removed the same way. Front passenger side anchor shown.

11. Remove four locknuts (23), washers (24), and anchor bolts (25) from fuel tank (7) and vehicle frame (26). Discard locknuts (23).

### WARNING

**Fuel tank is awkward. Do not attempt to lift or move fuel tank without the aid of an assistant and/or lifting device. Failure to comply may result in injury or death to personnel.**

12. With the aid of an assistant and lifting device, remove fuel tank (7) from vehicle.

**END OF TASK**

---

**INSTALLATION****WARNING**

**Fuel tank is awkward. Do not attempt to lift or move fuel tank without the aid of an assistant and/or lifting device. Failure to comply may result in injury or death to personnel.**

1. With the aid of an assistant and lifting device, position fuel tank (7) on vehicle.

**NOTE**

There are four anchor locations that secure fuel tank to vehicle frame. All anchors are installed the same way. Front passenger side anchor shown.

2. Secure fuel tank (7) on vehicle frame (26) with four anchor bolts (25), washers (24), and new locknuts (23).

**NOTE**

Install fuel level sensor as noted prior to removal.

3. Install new gasket (22) and fuel level sensor (21) on fuel tank (7) with five screws (20).

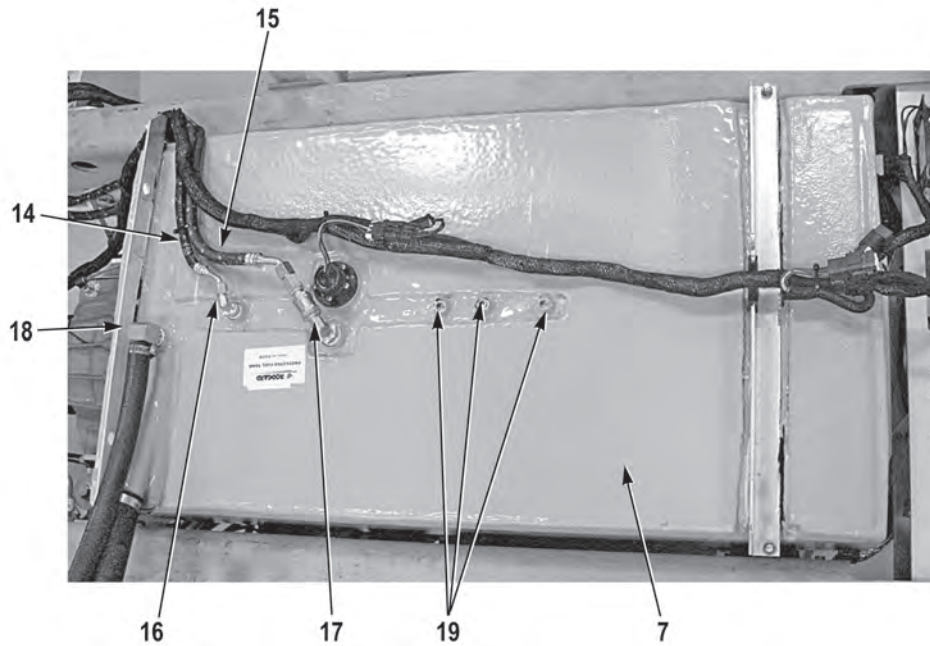

### **WARNING**

Adhesives, solvents, and sealing compounds can burn easily, can give off harmful vapors, and are harmful to skin and clothing. To avoid injury or death, keep away from open fire and use in well-ventilated area. If adhesive, solvent, or sealing compound gets on skin or clothing, wash immediately with soap and water. Failure to comply may result in injury or death to personnel.

### **NOTE**

- Install fittings as noted prior to removal.
  - Install cable ties as required.
4. Apply sealing compound, Loctite 592 to threads of three pipe plugs (19) and install pipe plugs (19) on fuel tank (7).
  5. Apply sealing compound, Loctite 592 to threads of three fittings (16, 17, and 18) and install fittings (16, 17, and 18) on fuel tank (7).
  6. Install two hoses (14 and 15) on fittings (16 and 17).



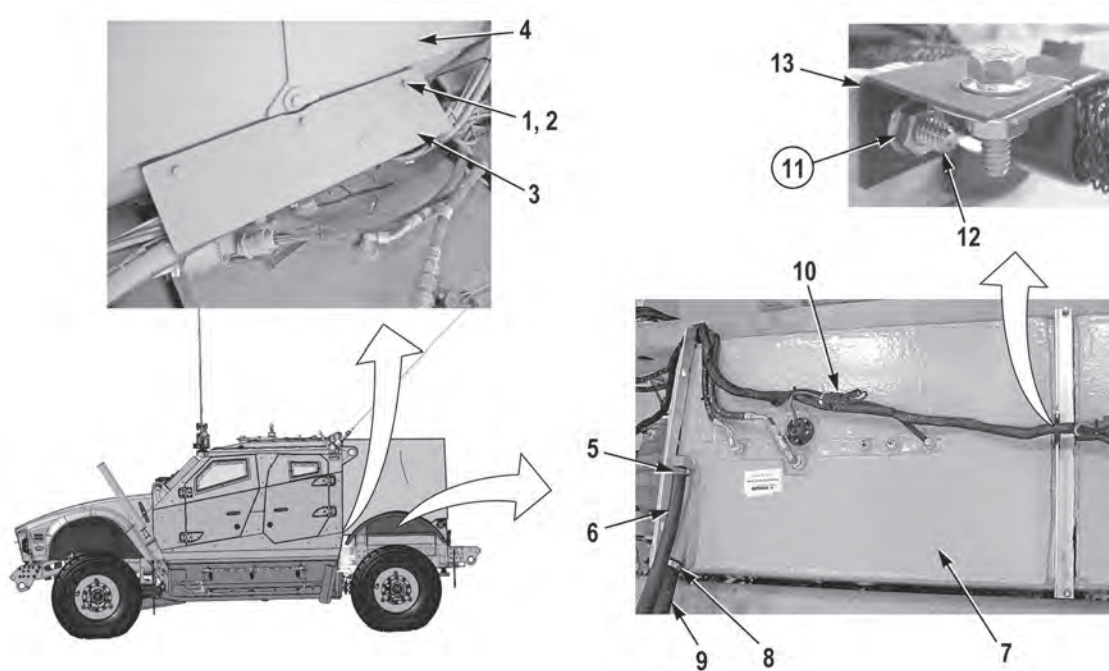

7. Install bracket (13) on fuel tank (7) with screw (12) and new locknut (11).
8. Connect connector (10).
9. Install filler hose (9) on fuel tank (7) with hose clamp (8).
10. Install fuel tank vent hose (6) on fuel tank (7) with hose clamp (5).
11. Install plate (3) on capsule (4) with three screws (2) and nuts (1).
12. Perform all Follow-On Maintenance tasks.

**END OF TASK**

**END OF WORK PACKAGE**



---

**FUEL/WATER SEPARATOR BASE REPLACEMENT**

---

**Preconditions**

Park vehicle  
 Engine OFF  
 Wheels chocked  
 Hood opened and secured  
 Fuel/water separator filter removed (WP 0266)

**Tools and Special Tools**

Tool Kit, General Mechanic's: Automotive

**Materials/Parts**

Lockwasher (2) (Item 8 and 13)  
 O-ring (4) (Item 16, 18, 19, and 21)  
 Cap and Plug Set

**Materials/Parts (continued)**

Fuel, JP8  
 Tags, Identification

**Follow-On Maintenance**

Install fuel/water separator (WP 0266)  
 Close hood and secure  
 Remove and stow wheel chocks

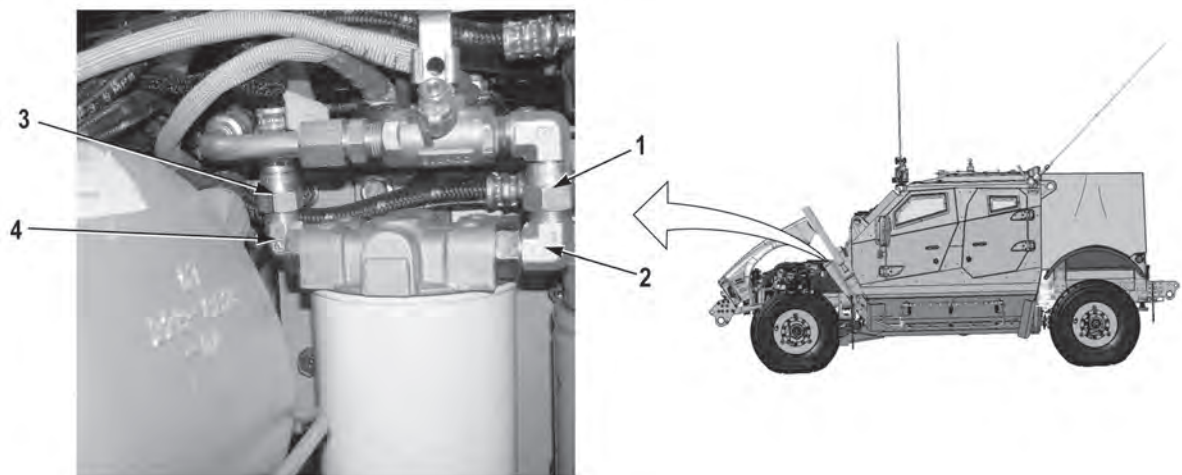
**REMOVAL****WARNING**

**Fuel is flammable and can explode. Keep fuel away from open flame and keep fire extinguisher within easy reach when working with fuel. Do not work on fuel system when engine is hot. Fuel can be ignited by hot engine. Smoking is prohibited while working with fuel. Failure to comply may result in injury or death to personnel.**

**NOTE**

- Tag and mark hoses and fittings prior to removal to ensure proper installation.
  - Cap and plug hoses and fittings upon removal.
1. Remove fitting (1) from fitting (2).
  2. Remove hose (3) from fitting (4).

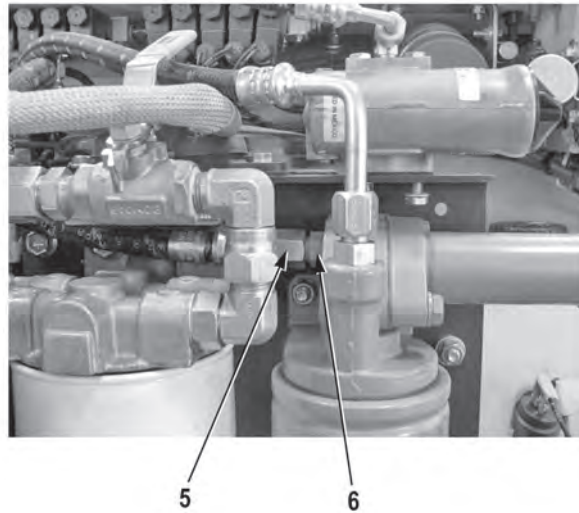

3. Remove hose (5) from fitting (6).

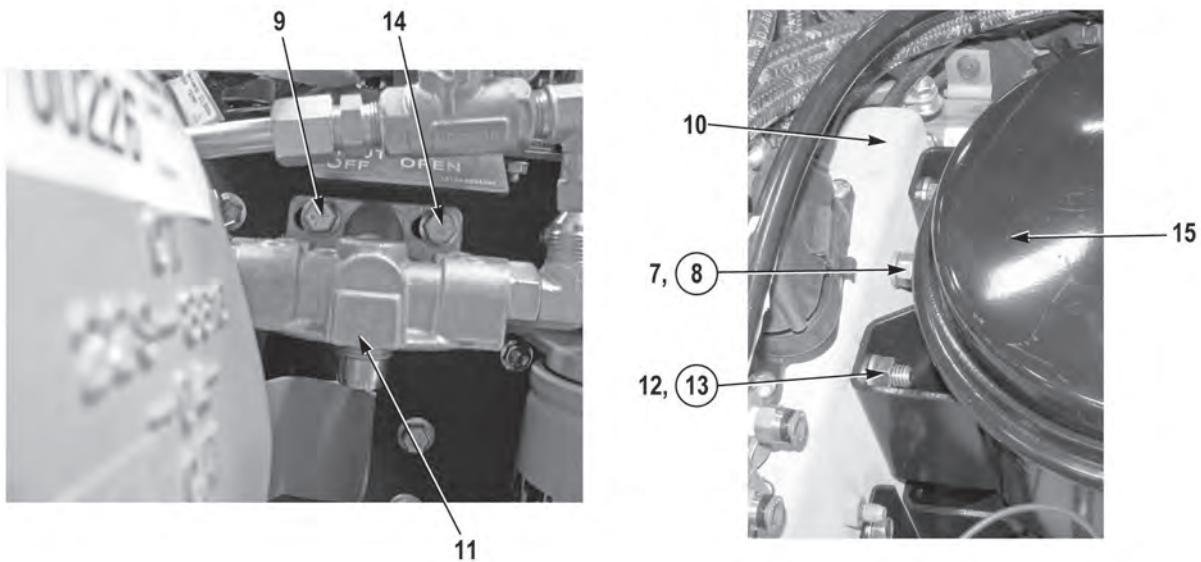

4. Remove nut (7), lockwasher (8), and screw (9) from bracket (10) and fuel/water separator base (11). Discard lockwasher (8).
5. Remove nut (12), lockwasher (13), screw (14), and fuel/water separator base (11) from power steering reservoir (15) and bracket (10). Discard lockwasher (13).

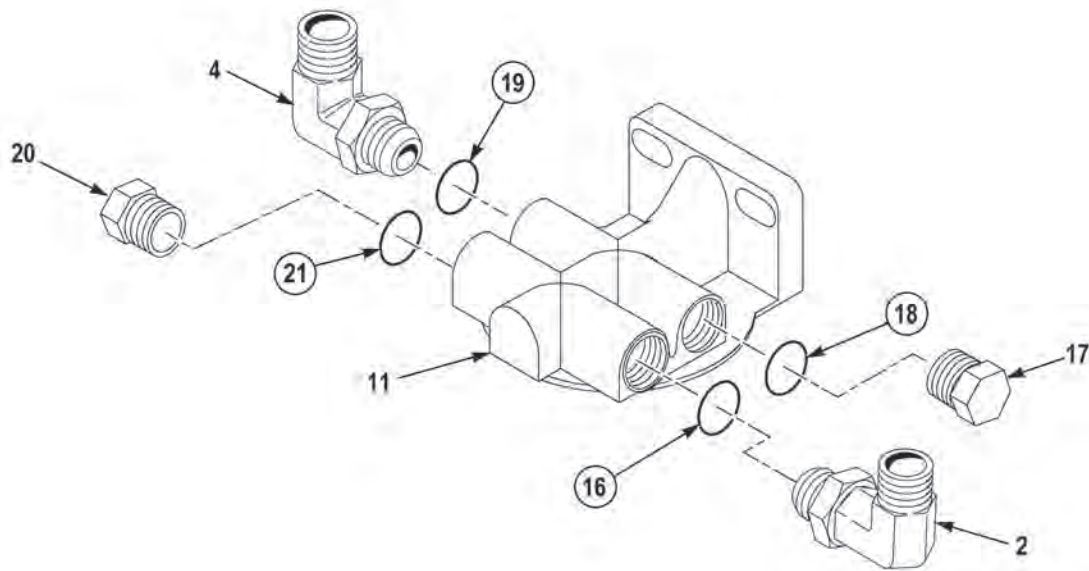

### NOTE

Note position of fittings and plugs prior to removal to ensure proper installation.

6. Remove fitting (2) and O-ring (16) from fuel/water separator base (11). Discard O-ring (16).
7. Remove plug (17) and O-ring (18) from fuel/water separator base (11). Discard O-ring (18).
8. Remove fitting (4) and O-ring (19) from fuel/water separator base (11). Discard O-ring (19).
9. Remove plug (20) and O-ring (21) from fuel/water separator base (11). Discard O-ring (21).

### END OF TASK

### INSTALLATION

### NOTE

Install fittings and plugs as noted prior to removal.

1. Apply clean fuel to new O-ring (21) and install O-ring (21) and plug (20) on fuel/water separator base (11).
2. Apply clean fuel to new O-ring (19) and install O-ring (19) and fitting (4) on fuel/water separator base (11).
3. Apply clean fuel to new O-ring (18) and install O-ring (18) and plug (17) on fuel/water separator base (11).
4. Apply clean fuel to new O-ring (16) and install O-ring (16) and fitting (2) on fuel/water separator base (11).
5. Install fuel/water separator base (11) on bracket (10) and power steering reservoir (15) with screw (14), new lockwasher (13), and nut (12).
6. Install screw (9) on fuel/water separator base (11) and bracket (10) with new lockwasher (8) and nut (7).
7. Install hose (5) on fitting (6).

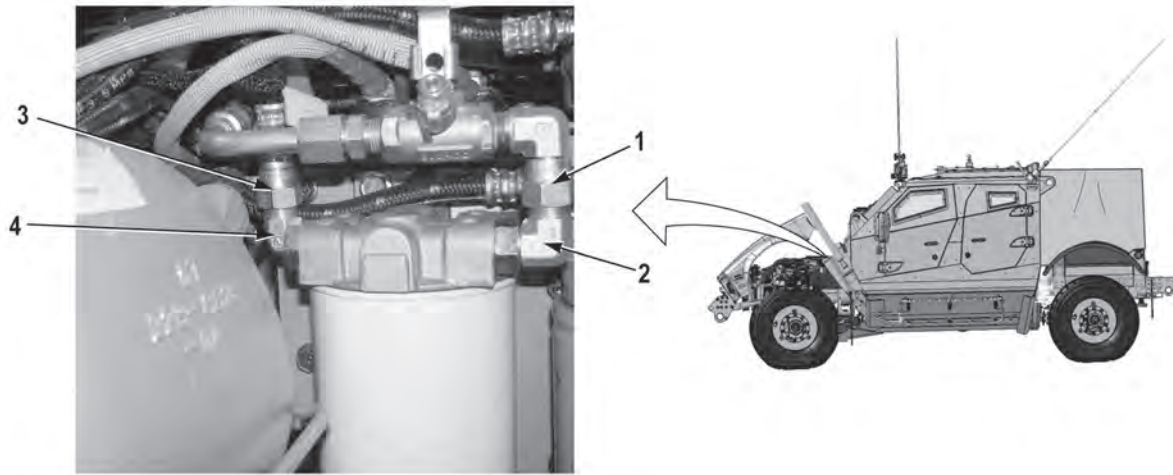

8. Install hose (3) on fitting (4).
9. Install fitting (1) on fitting (2).
10. Perform all Follow-On Maintenance tasks.

**END OF TASK**

**END OF WORK PACKAGE**



---

**FUEL/WATER SEPARATOR FILTER REPLACEMENT**

---

**Preconditions**

Park vehicle  
 Engine OFF  
 Wheels chocked  
 Hood opened and secured  
 Batteries disconnected (M1240/M1240A1)  
 (WP 0186)  
 Batteries disconnected (M1245) (WP 0187)

**Tools and Special Tools**

Pan, Drain  
 Tool Kit, General Mechanic's: Automotive  
 Wrench, Filter

**Materials/Parts**

Gasket (Item 5)  
 Element, Filter (Item 6)  
 Fuel, JP8

**Materials/Parts (continued)**

Gasket (Item 7)  
 Gasket (Item 10)  
 Lubricant, Connector  
 Lubrication Oil, Engine  
 Ties, Cable

**Follow-On Maintenance**

Connect batteries (M1240/M1240A1) (WP 0186)  
 Connect batteries (M1245) (WP 0187)  
 Prime fuel system  
 Close hood and secure  
 Remove and stow wheel chocks

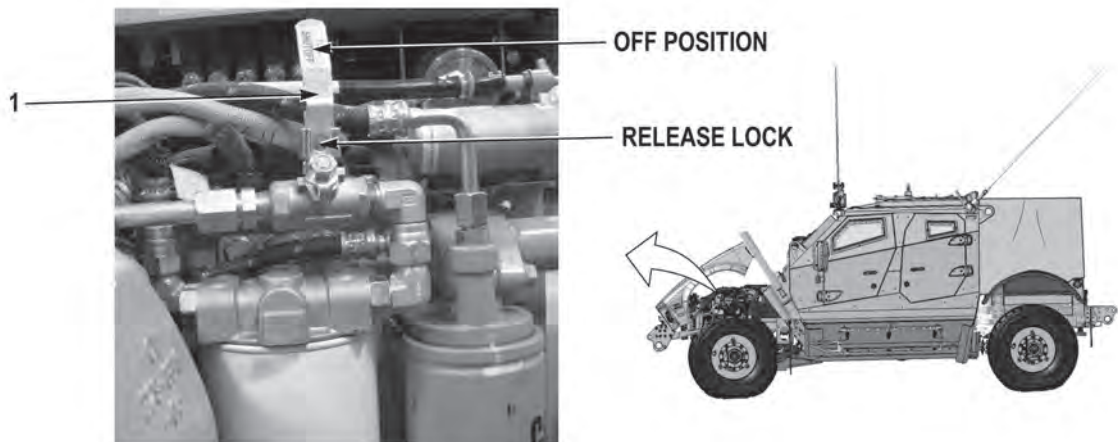
**REMOVAL****NOTE**

Remove cable ties as required.

1. Close fuel valve (1) by lifting release lock and moving fuel valve (1) to off position.

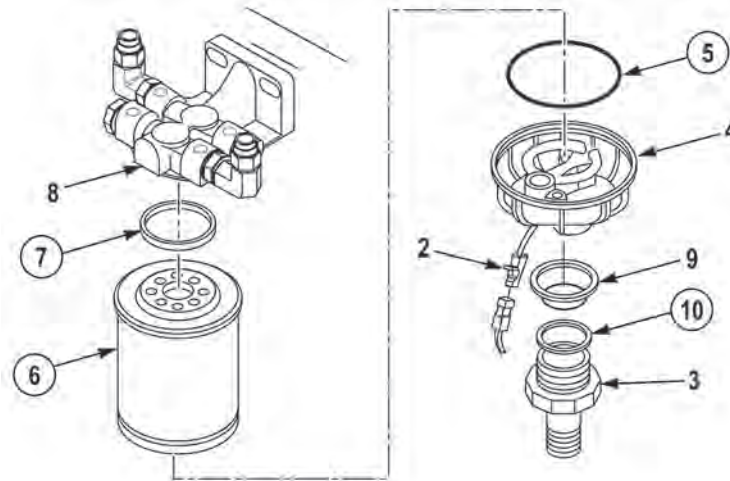

2. Disconnect connector (2).

### **WARNING**

**Fuel is flammable and can explode. Keep fuel away from open flame and keep fire extinguisher within easy reach when working with fuel. Do not work on fuel system when engine is hot. Fuel can be ignited by hot engine. Smoking is prohibited while working with fuel. Failure to comply may result in injury or death to personnel.**

3. Loosen drain valve (3) two full turns and drain fuel from sediment bowl (4).
4. Close drain valve (3).
5. Remove sediment bowl (4) and gasket (5) from filter element (6). Discard gasket (5).
6. Remove filter element (6) and gasket (7) from housing (8). Discard filter element (6) and gasket (7).
7. Clean foreign material from housing (8).

### **NOTE**

Perform Step (8) if drain valve and seal need to be removed.

8. Remove drain valve (3), seal (9), and gasket (10) from sediment bowl (4). Discard gasket (10).

### **END OF TASK**

### **INSTALLATION**

### **NOTE**

Perform Step (1) if drain valve and seal were removed.

1. Install new gasket (10), seal (9), and drain valve (3) on sediment bowl (4).
2. Lightly lubricate new gasket (5) with clean oil.

3. Install sediment bowl (4) and gasket (5) on filter element (6). Tighten 2/3 turn after gasket (5) contacts filter element (6).

### **WARNING**

**Fuel is flammable and can explode. Keep fuel away from open flame and keep fire extinguisher within easy reach when working with fuel. Do not work on fuel system when engine is hot. Fuel can be ignited by hot engine. Smoking is prohibited while working with fuel. Failure to comply may result in injury or death to personnel.**

4. Fill new filter element (6) and sediment bowl (4) with fuel.
5. Lightly lubricate new gasket (7) with clean oil.
6. Install filter element (6) and gasket (7) on housing (8). Tighten 2/3 turn after gasket (7) contacts housing (8).

### **WARNING**

**Connector lubricant is harmful to skin. Prolonged or repeated contact with skin or contact with eyes may cause irritation. If eyes are contacted, rinse thoroughly and contact physician if irritation persists. If skin is contacted, wash thoroughly with soap and water. Failure to comply may result in injury or death to personnel.**

7. Apply connector lubricant to connector (2).
8. Connect connector (2).

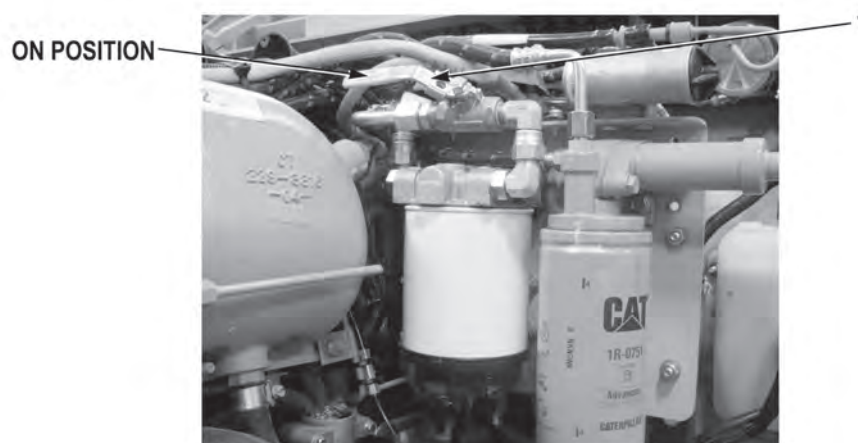

### **NOTE**

Install cables ties as required.

9. Open fuel valve (1) by moving fuel valve (1) to on position.
10. Perform all Follow-On Maintenance tasks.

**END OF TASK**

**END OF WORK PACKAGE**



---

**WINCH CABLE GUIDE AND GUARD REPLACEMENT**

---

**Preconditions**

Park vehicle  
Engine OFF  
Wheels chocked  
Winch cable removed (Standard SPARK)  
(WP 0268)  
Winch cable removed (Updated SPARK)  
(WP 0269)

**Tools and Special Tools**

Tool Kit, General Mechanic's: Automotive

**Materials/Parts**

None

**Follow-On Maintenance**

Install winch cable (Standard SPARK) (WP 0268)  
Install winch cable (Updated SPARK) (WP 0269)  
Remove and stow wheel chocks

---

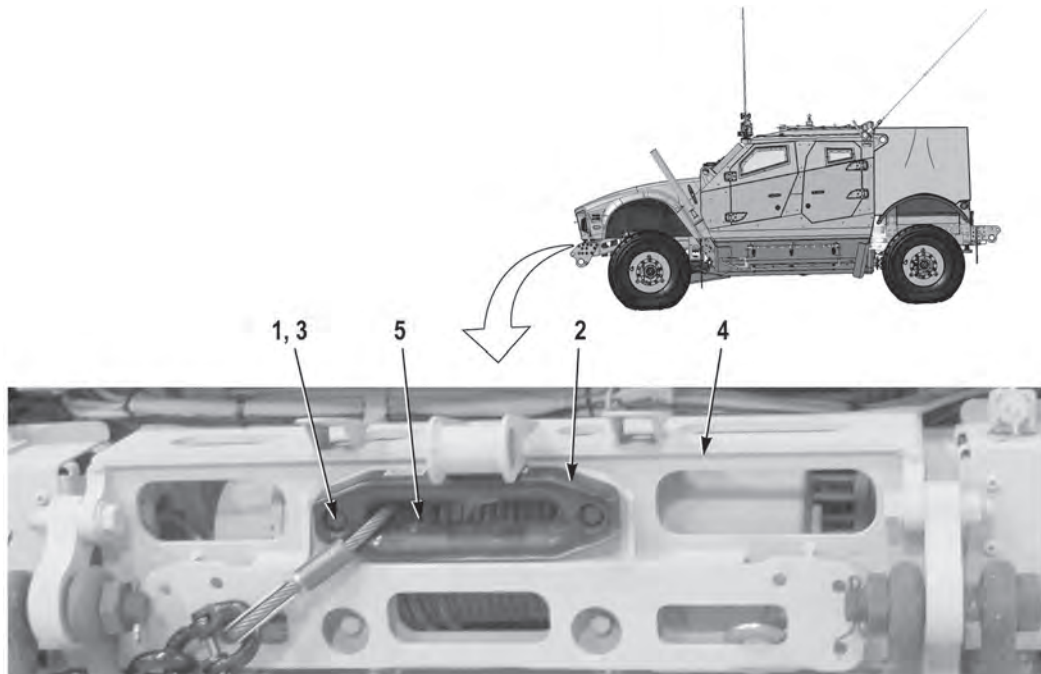
**REMOVAL**

1. Remove two caps (1) from cable guide (2).
2. Remove two screws (3) and cable guide (2) from front bumper (4) and winch (5).

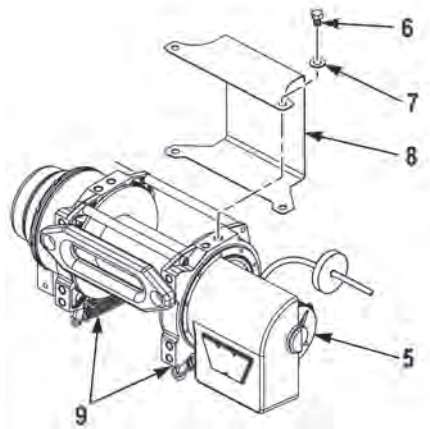

### NOTE

Perform Steps (3) and (4) if cable guard needs to be removed.

3. Remove winch (for standard spark bar refer to WP0271 or WP 0270 for updated spark bar).

### WARNING

**Springs and retaining rings are under extreme tension and can act as projectiles when being installed. Ensure all personnel wear protective goggles. Failure to comply may result in injury to personnel.**

### NOTE

- M1240 winch is equipped with a lock washer. Discard lockwasher.
- Perform Step (4) for vehicles equipped with standard spark bar.

4. Remove two screws (6), two washers (7), two springs (9), and cable guard (8) from winch (5).

### END OF TASK

### INSTALLATION

### WARNING

**Springs and retaining rings are under extreme tension and can act as projectiles when being installed. Ensure all personnel wear protective goggles. Failure to comply may result in injury to personnel.**

### NOTE

- M1240 winch is equipped with a lock washer. Replace with M1240A1 flat washer.
- Perform Steps (1) and (2) if cable guard needs to be installed.
- Perform Step (1) for vehicles equipped with standard spark bar.

1. Install cable guard (8) on winch (5) with two springs (9), two new flat washers (7), and screws (6).
2. Install winch (for standard spark bar refer to WP0271 or WP 0270 for updated spark bar).



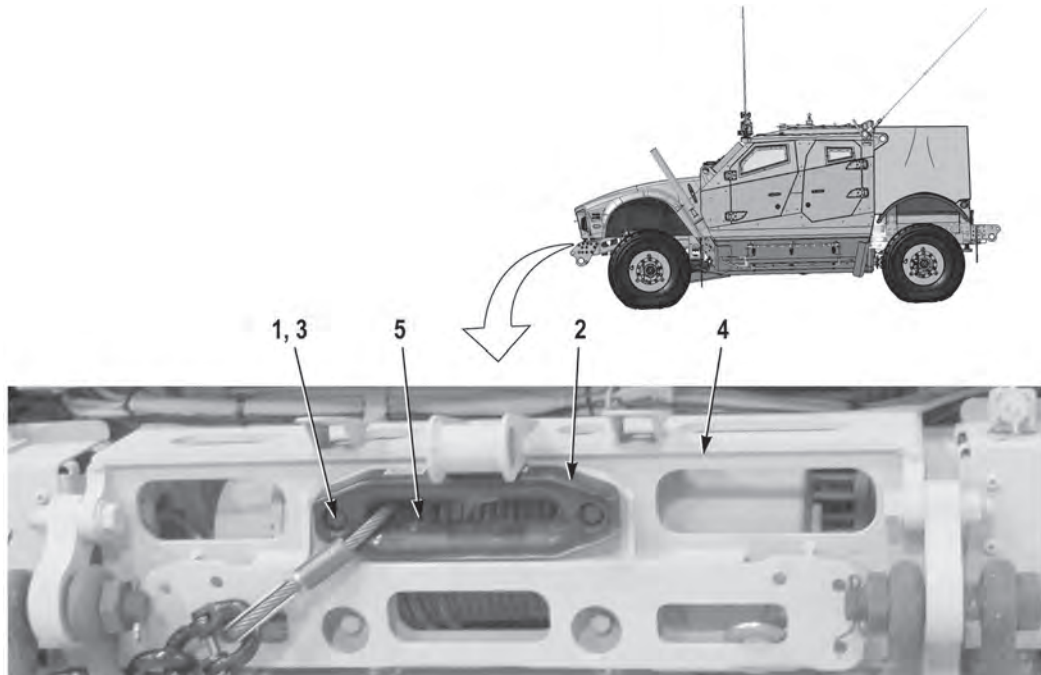

### NOTE

Lower winch screws may need to be loosened for ease of installation.

3. Install cable guide (2) on front bumper (4) and winch (5) with two screws (3).
4. Install two caps (1) on cable guide (2).
5. Perform all Follow-On Maintenance tasks.

**END OF TASK**

**END OF WORK PACKAGE**



---

**WINCH CABLE REPLACEMENT (STANDARD SPARK)**

---

**Preconditions**

Pay out winch cable  
Park vehicle  
Engine OFF  
Wheels chocked

**Materials/Parts**

Tape, Duct

**Follow-On Maintenance**

Stow winch cable  
Remove and stow wheel chocks

**Tools and Special Tools**

Tool Kit, General Mechanic's: Automotive

---

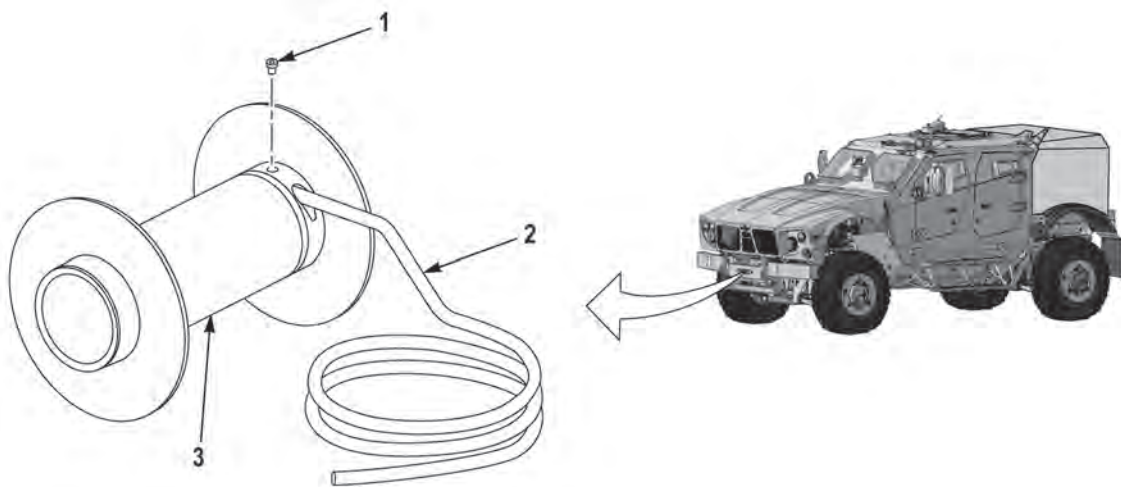
**REMOVAL****WARNING**

- Cable can become frayed or contain broken wires. Wear heavy leather-palmed gloves when handling cable. Never let moving cable slide through hands, even when wearing gloves. Failure to comply may result in injury to personnel.
- Do not wear watches or other jewelry when working on winch cable. Jewelry can catch on equipment. Failure to comply may result in injury to personnel.

**NOTE**

- If cable will not be replaced, store in a clean place to prevent dirt accumulation or damage.
- Take care to prevent any kinks from forming in cable, as this will weaken cable.

1. Remove screw (1) and cable (2) from drum (3) and vehicle.

**END OF TASK**

## INSTALLATION

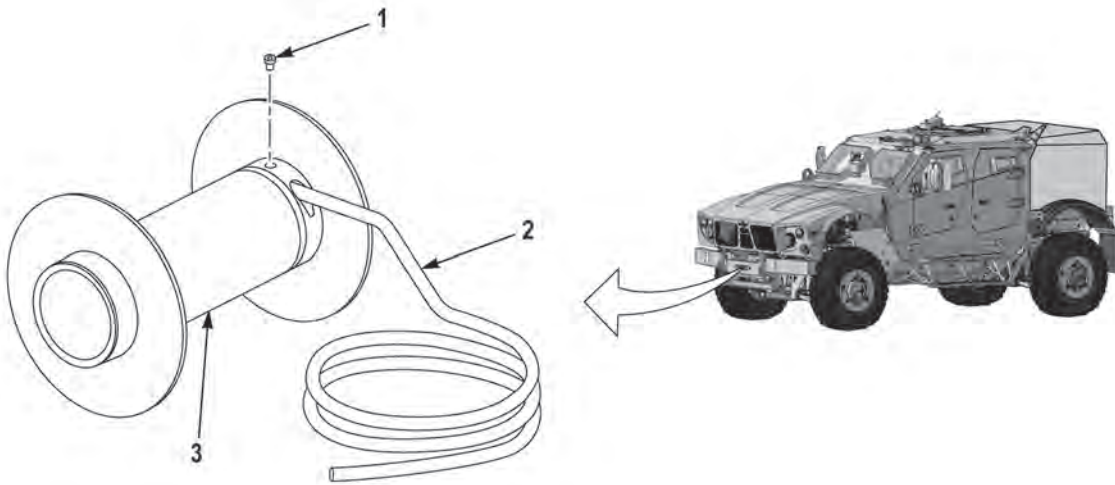

### **WARNING**

- Cable can become frayed or contain broken wires. Wear heavy leather-palmed gloves when handling cable. Never let moving cable slide through hands, even when wearing gloves. Failure to comply may result in injury to personnel.
- Do not wear watches or other jewelry when working on winch cable. Jewelry can catch on equipment. Failure to comply may result in injury to personnel.

### **CAUTION**

- The life of a wire rope directly relates to its use and to the care it receives. A wire rope must be “stretched” or spooled onto the drum under a load of at least 500 lbs (227 kg). The objective of “stretching” is to produce tight, even wraps on the inner and outer layers of the rope, thus preventing binding and kinking. Failure to comply may result in injury to personnel.
- Do not overtighten screw. Failure to comply may result in damage to equipment.

### **NOTE**

- When installing, cable must be spooled under a load of 500 lbs (227 kg).
- End of cable must extend to other end of hole.
- Small piece of tape wound around end of cable will aid in installation.

1. Install cable (2) on drum (3) with screw (1). Tighten screw to 12 to 15 lb-ft (16 to 20 N•m).
2. Perform all Follow-On Maintenance tasks.

**END OF TASK**

**END OF WORK PACKAGE**

---

## WINCH CABLE REPLACEMENT (UPDATED SPARK)

---

**Preconditions**

Park vehicle  
 Engine OFF  
 Wheels chocked  
 Pay out winch cable  
 Air system drained

**Tools and Special Tools**

Ball Valve, 3/8 in.  
 Elbow, Quick Disconnect  
 Gloves, Welder  
 Plug, Fitting (as required)  
 Screwdriver Attachment, 3/8 in. Dr., 5 mm  
 Tool Kit, General Mechanic's: Automotive  
 Wrench, Torque, 0 to 300 in-lb

**Materials/Parts**

Compound, Sealing, Loctite 567  
 Tape, Insulation, Electrical  
 Tubing, Nonmetallic

**Follow-On Maintenance**

Stow winch cable  
 Remove and stow wheel chocks

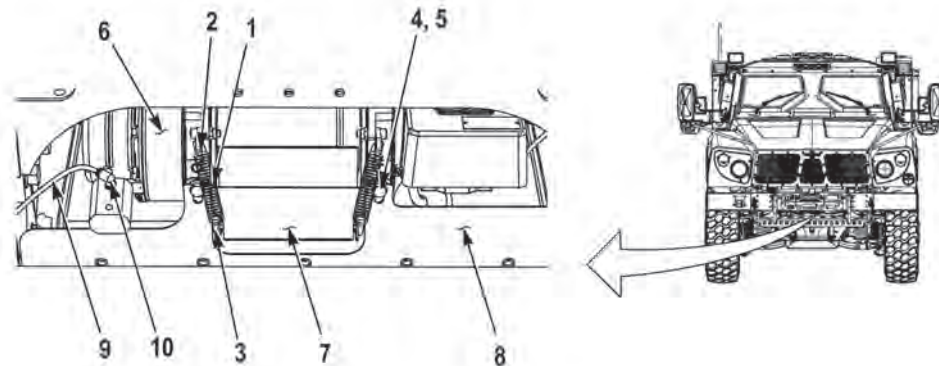
**REMOVAL****WARNING**

**Wear proper eye protection and use care when removing or installing springs, retaining rings, and snap rings. Springs, retaining rings, and snap rings are under spring tension and can act as projectiles when released. Spring must be compressed during assembly. Failure to comply may result in injury to personnel.**

**NOTE**

Perform Steps (1) and (2) as required.

1. Remove two springs (1) from brackets (2) and brackets (3).
2. Remove two screws (4) and washers (5) from winch (6), winch guard (7), and panel (8).
3. Disconnect air line (9) from fitting (10).

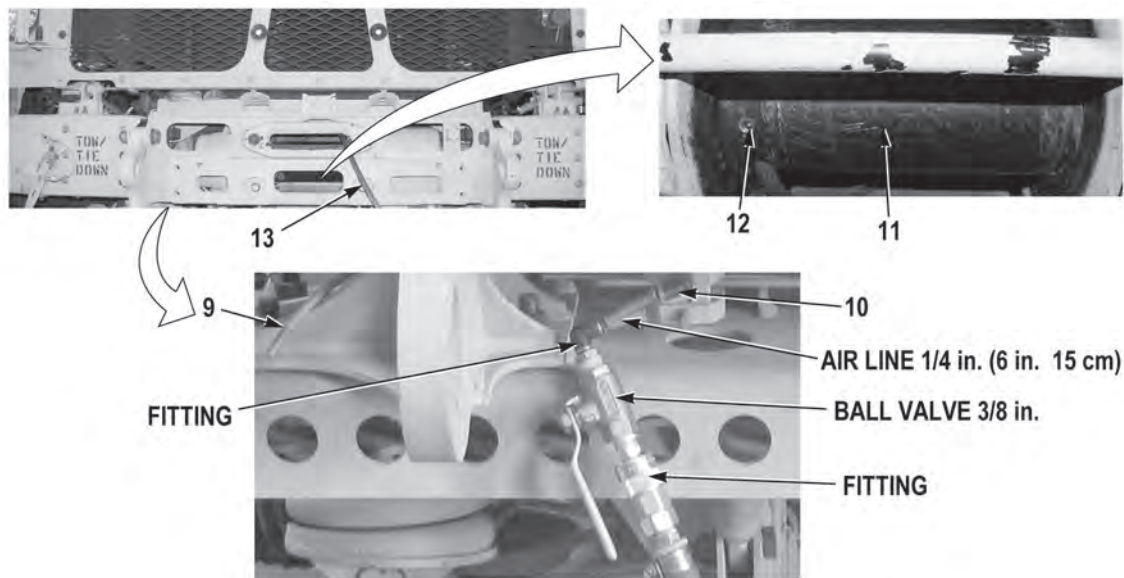

### **WARNING**

Adhesives, solvents, and sealing compounds can burn easily, can give off harmful vapors, and are harmful to skin and clothing. To avoid injury or death, keep away from open fire and use in well-ventilated area. If adhesive, solvent, or sealing compound gets on skin or clothing, wash immediately with soap and water. Failure to comply may result in injury or death to personnel.

### **NOTE**

Air fitting requirements may vary depending on tools and supplies available.

4. Apply sealing compound, Loctite 567, to threads of two fittings and install two fittings on ball valve.
5. Connect 1/4 in. air line on fitting.
6. Connect 1/4 in. air line on ball valve tool to fitting (10) and connect ball valve tool to air supply.
7. Open ball valve to release drum (11).
8. Turn drum (11) until setscrew (12) is accessible.
9. Close ball valve and remove 1/4 in. air line on ball valve tool from fitting (10).

### **WARNING**

- Cable can become frayed or contain broken wires. Wear heavy leather-palmed gloves when handling cable. Never let moving cable slide through hands, even when wearing gloves. Failure to comply may result in injury or death to personnel.
- Do not wear watches or other jewelry when working with winch cable. Jewelry can catch on equipment. Failure to comply may result in injury or death to personnel.



**CAUTION**

**Take care to prevent kinks from forming in cable, as this will weaken cable. Failure to comply may result in damage to equipment.**

**NOTE**

If cable will not be replaced, store in a clean place to prevent dirt accumulation or damage.

10. Remove setscrew (12) and cable (13) from drum (11).
11. Connect air line (9) on fitting (10).

**END OF TASK****INSTALLATION**

1. Disconnect air line (9) from fitting (10).
2. Connect 1/4 in. air line on ball valve tool to fitting (10) and open ball valve to release drum (11).
3. Turn drum (11) until setscrew (12) hole reaches top position.

**WARNING**

- **Cable can become frayed or contain broken wires. Wear heavy leather-palmed gloves when handling cable. Never let moving cable slide through hands, even when wearing gloves. Failure to comply may result in injury or death to personnel.**
- **Do not wear watches or other jewelry when working with winch cable. Jewelry can catch on equipment. Failure to comply may result in injury or death to personnel.**

**CAUTION**

- **The life of a cable directly relates to its use and to the care it receives. A cable must be “stretched” or spooled onto the drum under a load of at least 500 lbs (227 kg). The objective of “stretching” is to produce tight, even wraps on the inner and outer layers of the cable, thus preventing binding or kinking. Failure to comply may result in damage to equipment.**
- **Do not overtighten setscrew. Failure to comply may result in damage to equipment.**

**NOTE**

- End of cable must extend to other end of hole in drum.
  - Small piece of tape wound around end of cable will aid in installation.
4. Install cable (13) on drum (11).
  5. While holding cable (13) in place, turn drum (11) until setscrew (12) is accessible.
  6. Close ball valve and remove 1/4 in. air line on ball valve tool from fitting (10).
  7. Secure cable (13) on drum (11) with setscrew (12). Tighten setscrew (12) to 141 to 177 lb-in (16 to 20 N•m).

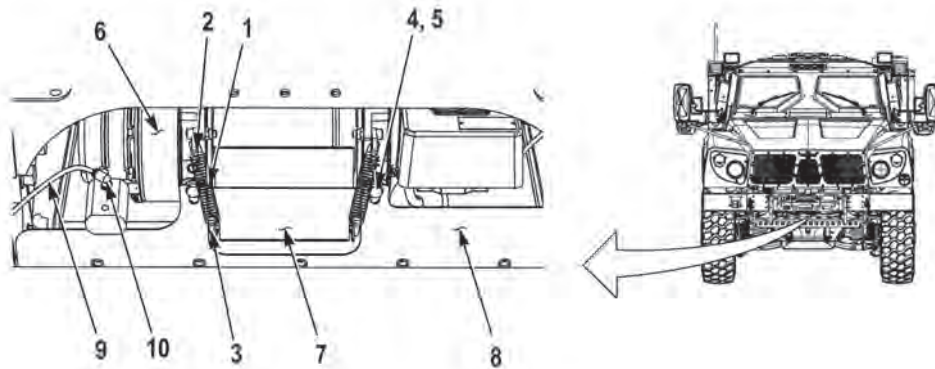

8. Connect air line (9) on fitting (10).

#### **NOTE**

Perform Steps (9) and (10) as required.

9. Secure winch guard (7) on panel (8) and winch (6) with two washers (5) and screws (4).

#### **WARNING**

**Wear proper eye protection and use care when removing or installing springs, retaining rings, and snap rings. Springs, retaining rings, and snap rings are under spring tension and can act as projectiles when released. Valve is spring loaded. Spring must be compressed during assembly. Failure to comply may result in injury to personnel.**

10. Install two springs (1) on brackets (3) and brackets (2).  
 11. Perform all Follow-On Maintenance tasks.

**END OF TASK**

**END OF WORK PACKAGE**

---

**WINCH/FRONT CROSSMEMBER REPLACEMENT (UPDATED SPARK)**

---

**Preconditions**

Park vehicle  
Engine OFF  
Wheels chocked  
Winch cable removed (WP 0269)  
Winch cable guide removed (WP 0267)  
Front bumper removed (WP 0251)

**Tools and Special Tools**

Breaker Bar 3/4 in.  
Cap and Plug Set  
Jack Kit, Hyd Hand, 20 Ton Cap  
Lifting Device  
Ratchet, 3/4 in. Dr., 20 in. Long  
Socket, Standard, 1-1/8 in., 3/4 in. Dr.  
Shackles, Qty: 2  
Strap, Nylon, 60 in.  
Tool Kit, General Mechanic's: Automotive  
Wrench, Combination 1-1/8 in.  
Wrench, Torque, 250 ft-lb

**Materials/Parts**

Locknut (2) (Item 1 and 5)  
Locknut (10) (Item 11)  
Locknut (4) (Item 20)  
Lockwasher (2) (Item 32)  
Sealant, RTV Electric  
Tags, Identification  
Ties, Cable

**Personnel Required**

Two

**Follow-On Maintenance**

Install front bumper (WP 0251)  
Install winch cable guide (WP 0267)  
Install winch cable (WP 0269)  
Remove and stow wheel chocks

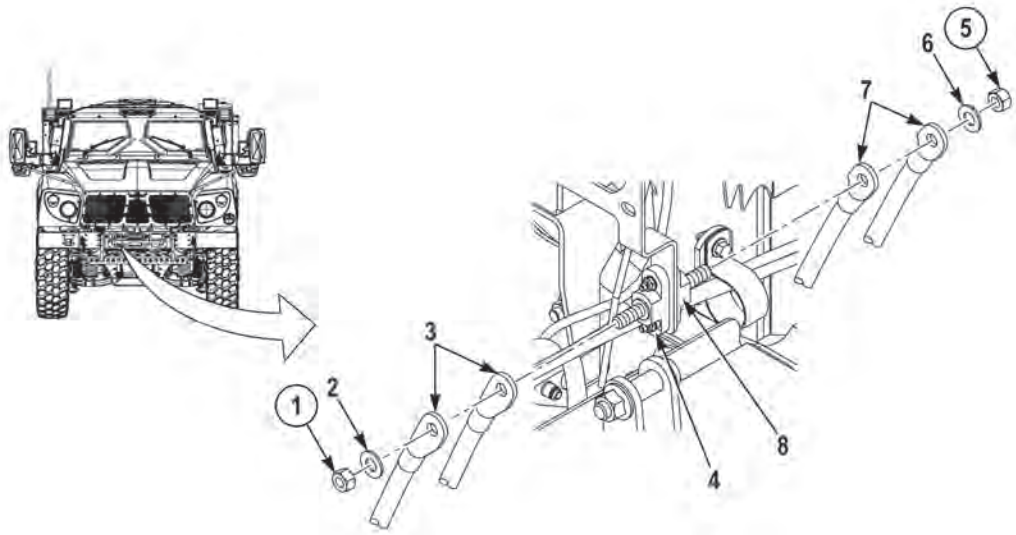
**REMOVAL****NOTE**

- Tag and mark cables prior to removal to ensure proper installation.
  - Number of cables needed to be removed may vary depending on the order in which they were installed.
  - Cables not being removed can be reinstalled on junction blocks for ease of identification.
1. Remove locknut (1), washer (2), and two negative winch cables (3) from junction block (4). Discard locknut (1).
  2. Remove locknut (5), washer (6), and two positive winch cables (7) from junction block (8). Discard locknut (5).

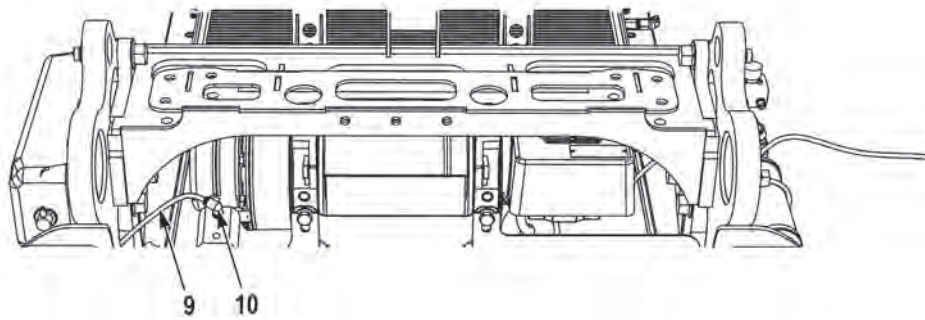

### **WARNING**

- Air system must be drained prior to removing air system components. Failure to comply may result in injury or death to personnel.
- Air lines under pressure will move violently when removed. Ensure air system is drained prior to removing air lines. Failure to comply may result in injury or death to personnel.

### **NOTE**

- Tag and mark air lines prior to removal to ensure proper installation.
  - Cap and plug air lines and fittings upon removal.
  - Remove cable ties are required.
3. Remove air line (9) from fitting (10).

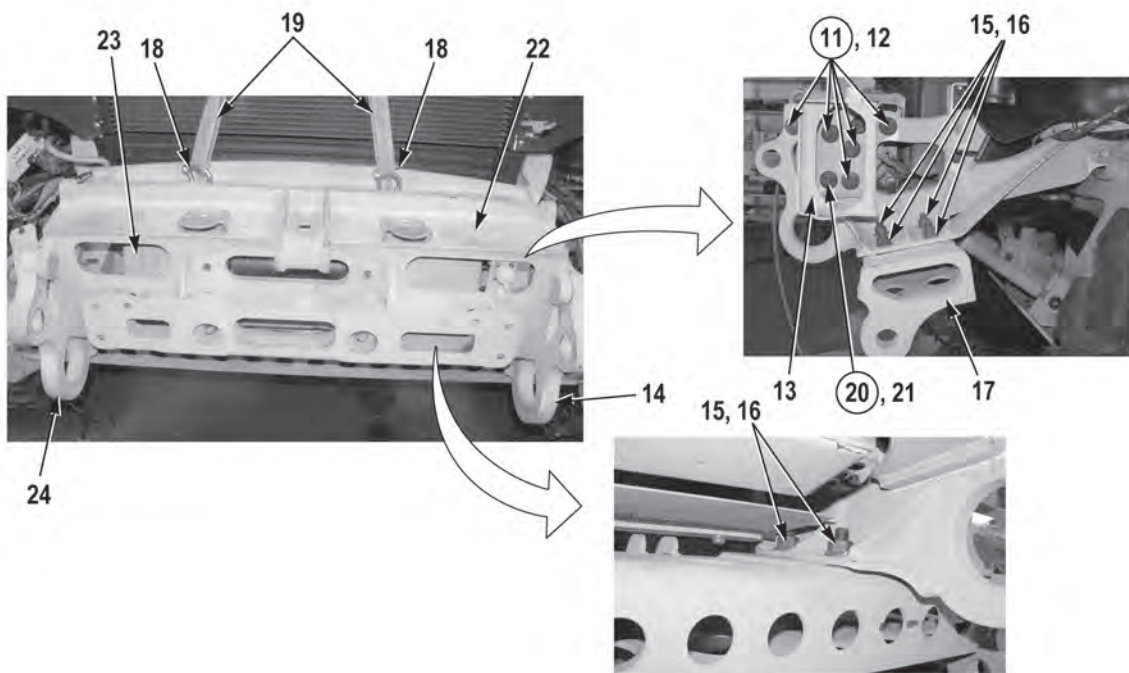
**NOTE**

Note location of hardware prior to removal to ensure proper installation.

4. Remove five locknuts (11), screws (12), and driver side bumper support bracket (13) from driver side frame extension (14).
5. Repeat Step (4) for passenger side bumper support bracket.

**NOTE**

- Hardware loosened in Step (6) are locknuts on each side, closest to driver side frame extension.
  - Perform Step (6) to aid assistance of winch removal.
6. Loosen six locknuts (15) and screws (16) on driver side frame extension (14) and lower spark bar (17).

**WARNING**

**Winch and front crossmember are removed/installed as an assembly. Winch and front crossmember weigh 214 lbs (97 kg). Do not lift or move winch and crossmember without the aid of an assistant and a lifting device. Failure to comply may result in injury or death to personnel.**

**NOTE**

The aid of a hydraulic spreader jack may be required to remove front crossmember from front frame extensions.

7. With the aid of an assistant, a lifting device, two shackles (18), and a strap (19) remove four locknuts (20), screws (21), front crossmember (22), and winch (23) from driver side frame extension (14) and passenger side frame extension (24). Discard locknuts (20).



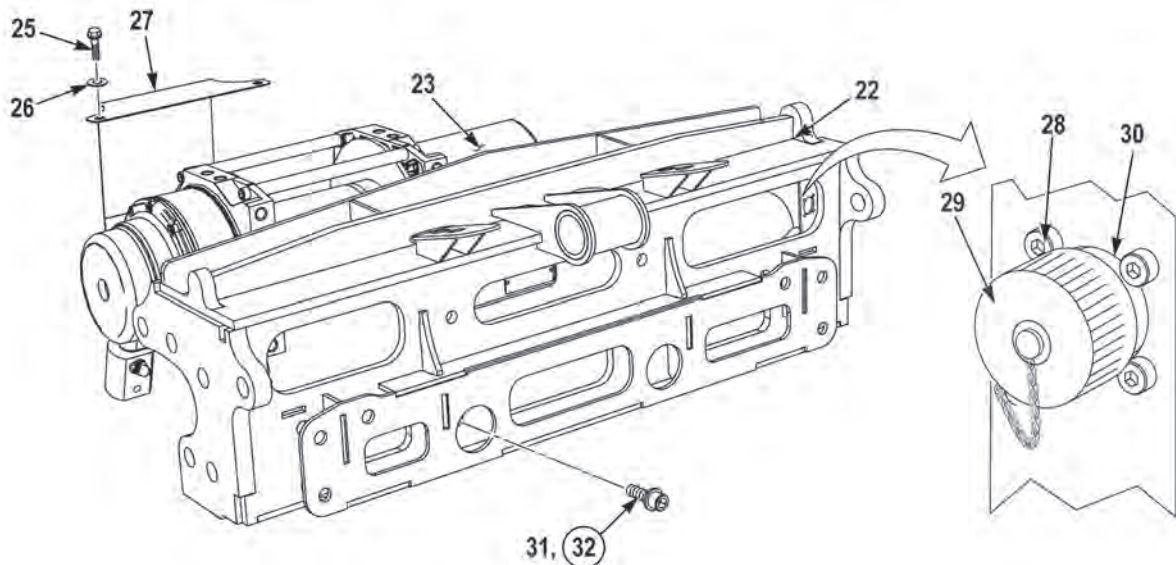

### **WARNING**

**Winch weighs 119 lbs (54 kg). Do not lift or move winch without the aid of an assistant and a lifting device. Failure to comply may result in injury or death to personnel.**

### **NOTE**

- Perform Step (8) if winch guard needs to be removed.
- Note position of winch guard prior to removal to ensure proper installation.
- Note position and remove cushion clips as required.

8. Remove two screws (25), washers (26), and winch guard (27) from winch (23).

### **NOTE**

Perform Steps (9) and (10) if winch needs to be removed.

9. Remove four screws (28), cover (29), and remote connector (30) from front crossmember (22).
10. With the aid of an assistant and a lifting device, remove two screws (31), lockwashers (32), and winch (23) from front crossmember (22). Discard lockwashers (32).

**END OF TASK**

## INSTALLATION

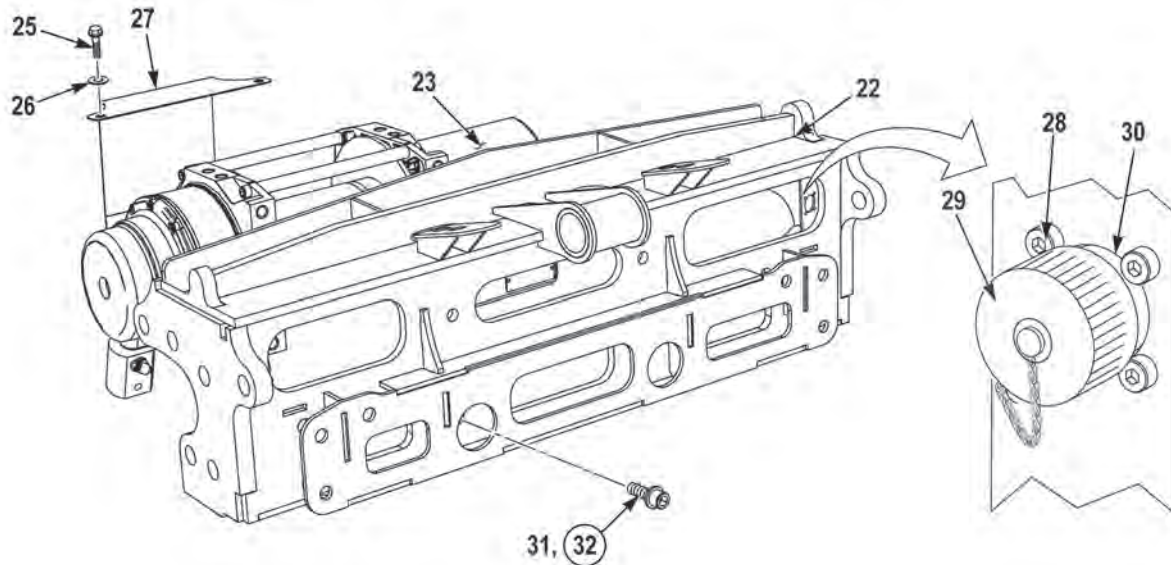

### **WARNING**

**Winch weighs 119 lbs (54 kg). Do not lift or move winch without the aid of an assistant and a lifting device. Failure to comply may result in injury or death to personnel.**

### **NOTE**

Perform Step (1) and (2) if winch was removed.

1. With the aid of an assistant and a lifting device, install winch (23) on front crossmember (22) with two new lockwashers (32) and screws (31). Tighten screws (31) to 70 lb-ft (95 N•m).
2. Install remote connector (30) and cover (29) on front crossmember (22) with four screws (28).

### **NOTE**

- Perform Step (3) if winch guard was removed.
  - Install winch guard as noted prior to removal.
  - Install cushion clips as noted prior to removal.
3. Install winch guard (27) on winch (23) with two washers (26) and screws (25).

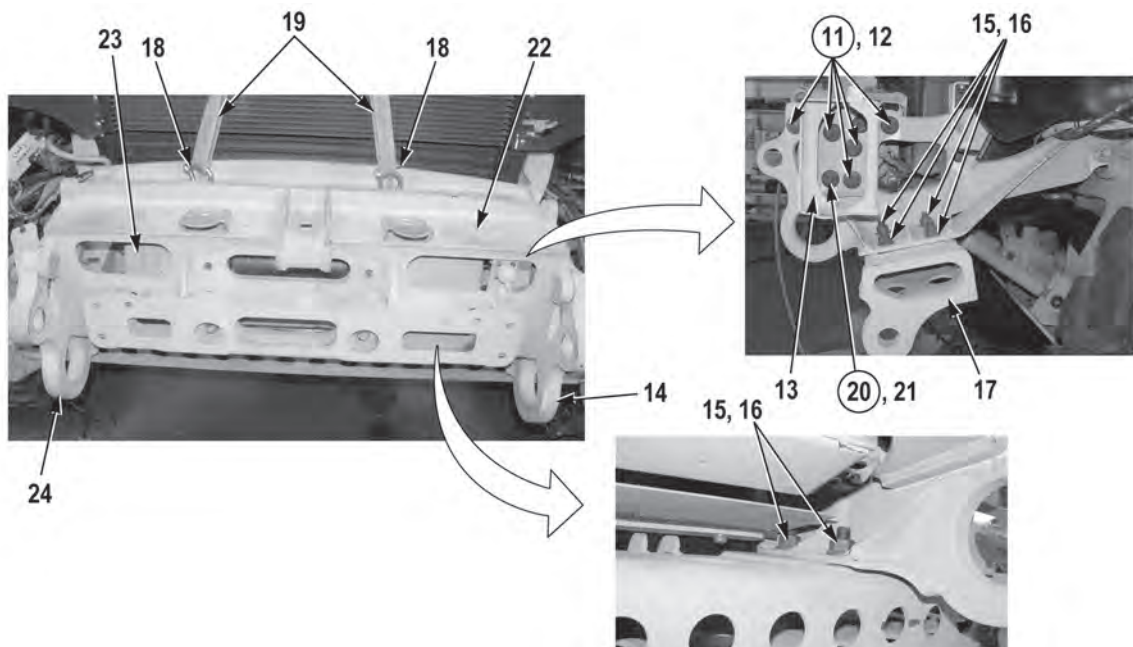

### **WARNING**

**Winch and front crossmember are removed/installed as an assembly. Winch and front crossmember weigh 214 lbs (97 kg). Do not lift or move winch and crossmember without the aid of an assistant and a lifting device. Failure to comply may result in injury or death to personnel.**

### **NOTE**

The aid of a hydraulic spreader jack maybe required to install winch and front crossmember on front frame extensions.

4. With the aid of an assistant, a lifting device, two shackles (18), and strap (19) install winch (23) and front crossmember (22) on passenger side frame extension (24) and driver side frame extension (14) with four screws (21) and new locknuts (20). Do not tighten locknuts (20). Remove lifting device from vehicle.

### **NOTE**

- Hardware tightened in Step (5) are locknuts on each side, closest to driver side frame extension.
  - Perform Step (5) if screws were loosened in removal.
5. Tighten six screws (16) and locknuts (15) on lower spark bar (17) and driver side frame extension (14).

### **NOTE**

Install hardware as noted prior to removal.

6. Install driver side bumper support bracket (13) on driver side frame extension (14) with five screws (12) and new locknuts (11). Do not tighten locknuts (11).
7. Repeat Step (6) for passenger side bumper support bracket.
8. Tighten locknuts (20) and (11).

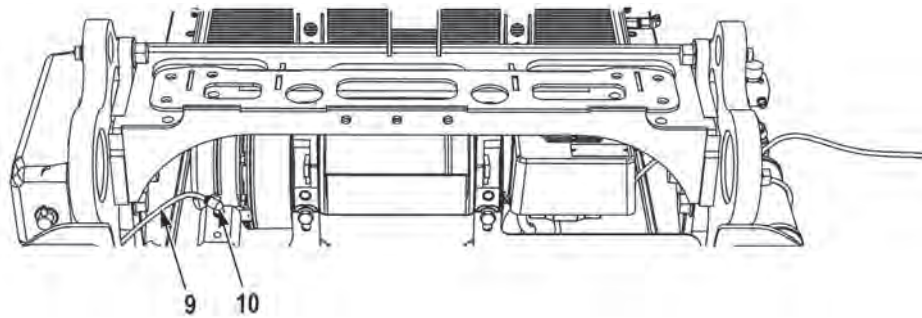

### NOTE

Install cable ties as required.

9. Install air line (9) on fitting (10).

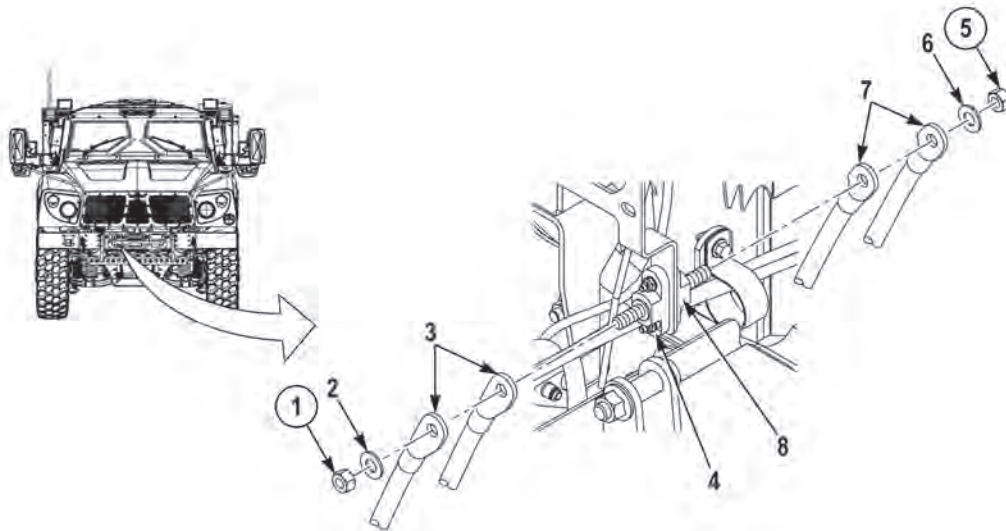

10. Install two positive winch cables (7) on junction block (8) with washer (6) and new locknut (5).
11. Install two negative winch cables (3) on junction block (4) with washer (2) and new locknut (1).

### WARNING

**Adhesives, solvents, and sealing compounds can burn easily, can give off harmful vapors, and are harmful to skin and clothing. To avoid injury or death, keep away from open fire and use in well-ventilated area. If adhesive, solvent, or sealing compound gets on skin or clothing, wash immediately with soap and water. Failure to comply may result in injury or death to personnel.**

12. Apply sealant, RTV to junction blocks (8 and 4) and all exposed cable ends.
13. Perform all Follow-On Maintenance tasks.

**END OF TASK**

**END OF WORK PACKAGE**

---

**WINCH REPLACEMENT (STANDARD SPARK)**

---

**Preconditions**

Park vehicle  
 Engine OFF  
 Wheels chocked  
 Winch cable removed (WP 0268)  
 Batteries disconnected (M1240) (WP 0186)  
 Air system drained

**Tools and Special Tools**

Jack Kit, Hydraulic Hand  
 Lifting Device  
 Tool Kit, General Mechanic's: Automotive

**Materials/Parts**

Lockwasher (2) (Item 2 and 7)  
 Locknut (12) (Item 22)

**Materials/Parts (continued)**

Cap and Plug Set  
 Compound, Sealing, Novagard, RTV 200-257  
 Tags, Identification  
 Ties, Cable

**Personnel Required**

Two

**Follow-On Maintenance**

Connect batteries (M1240) (WP 0186)  
 Install winch cable (WP 0268)  
 Remove and stow wheel chocks

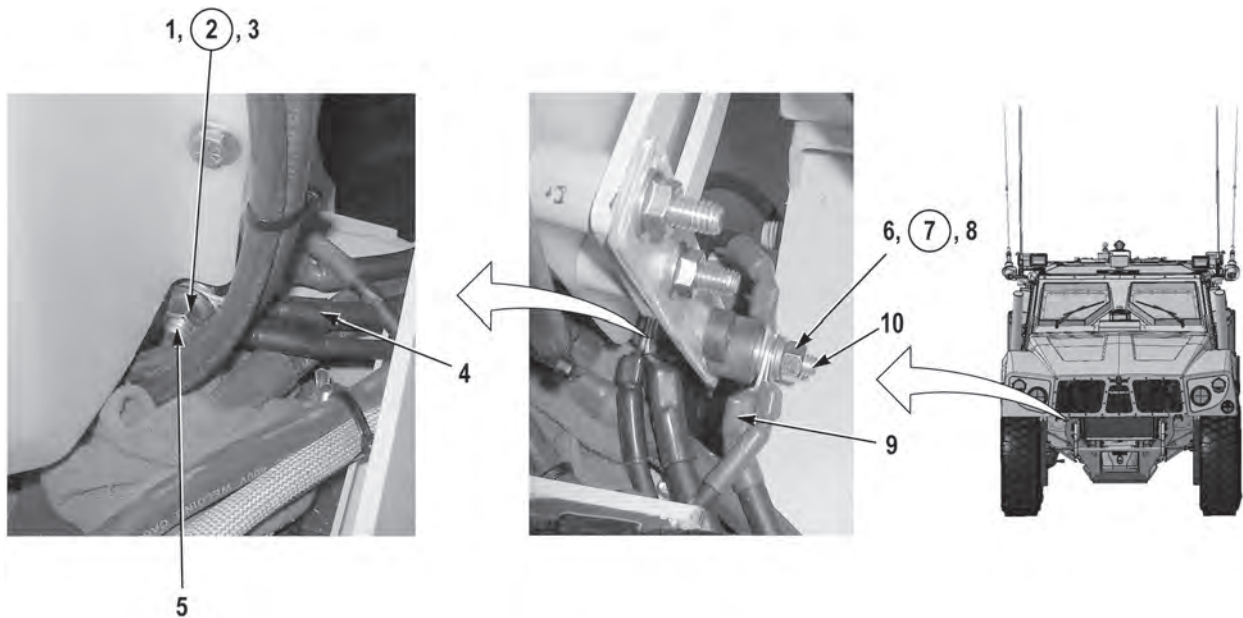
**REMOVAL****NOTE**

Tag and mark cables prior to removal.

1. Remove nut (1), lockwasher (2), washer (3), and negative cable (4) from stud (5). Discard lockwasher (2).
2. Remove nut (6), lockwasher (7), washer (8), and positive cable (9) from stud (10). Discard lockwasher (7).

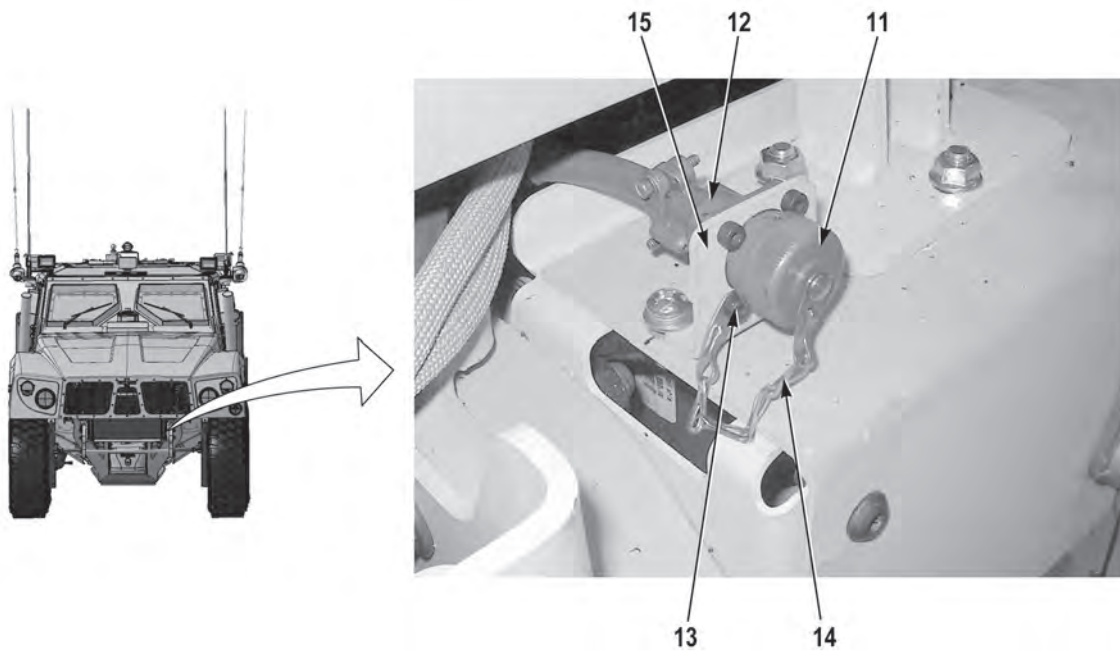

**NOTE**

Remove cushion clips and cable ties as required.

3. Remove cap (11) from winch connector (12).
4. Remove four screws (13), chain (14), and winch connector (12) from bracket (15).



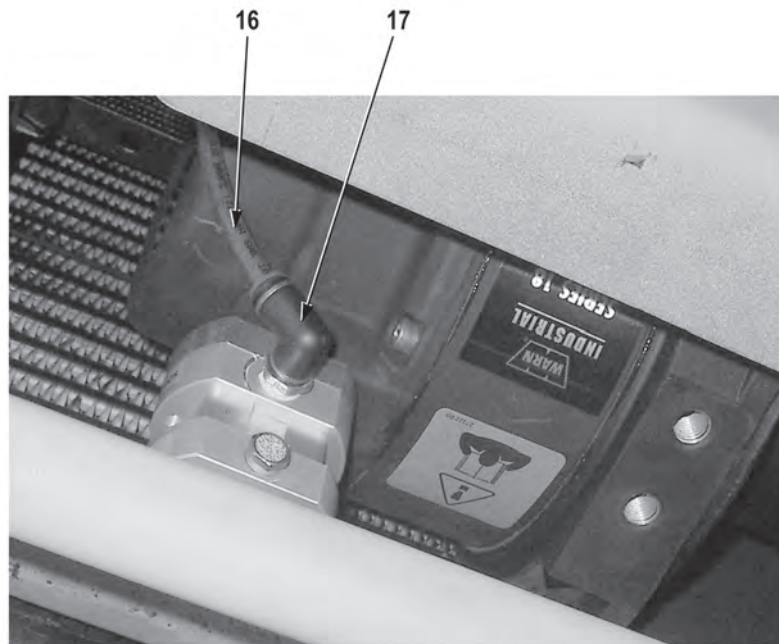

### **WARNING**

- **Ensure air system is drained prior to working on air system components. Failure to comply may result in injury or death to personnel.**
- **Air lines under pressure will move violently when removed. Ensure air system is drained prior to removing air lines. Failure to comply may result in injury or death to personnel.**

### **NOTE**

- Tag and mark air lines and fittings prior to removal to ensure proper installation.
  - Cap and plug air lines and fittings upon removal.
  - Remove cable ties as required.
5. Remove air line (16) from fitting (17).

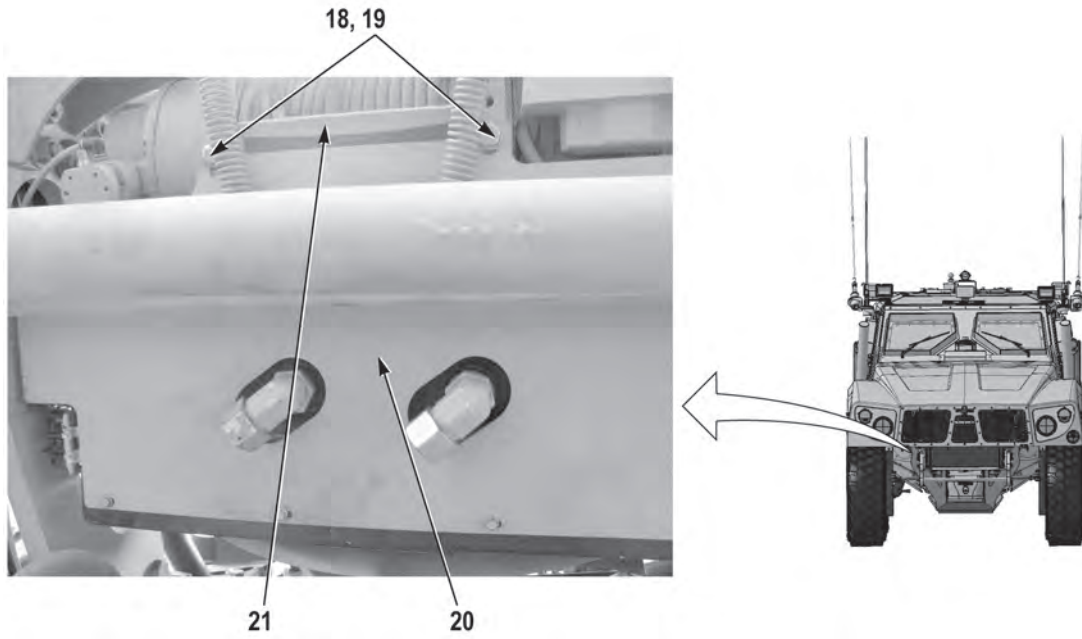

6. Remove two screws (18) and washers (19) from baffle (20) and winch (21).

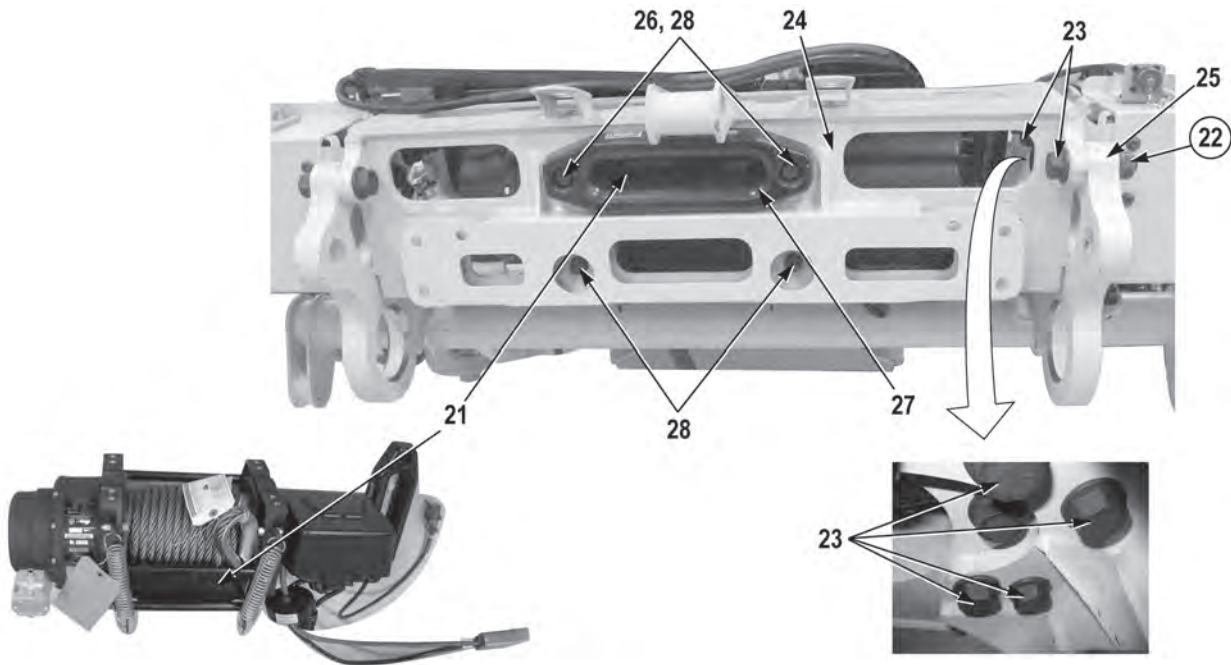

---

**WARNING**

**Winch and winch bracket are removed as an assembly. Winch and winch bracket weigh 167 lbs (76 kg). Do not lift or move winch bracket without the aid of an assistant and/or a lifting device. Failure to comply may result in injury or death to personnel.**

7. With the aid of an assistant and a lifting device, remove 12 locknuts (22), screws (23), winch bracket (24), and winch (21) from frame brackets (25). Discard locknuts (22).
8. Remove two caps (26) from cable guide (27).
9. Remove four screws (28), cable guide (27), and winch (21) from winch bracket (24).

**END OF TASK****INSTALLATION**

1. Install cable guide (27) and winch (21) on winch bracket (25) with four screws (26).
2. Install two caps (26) on cable guide (27).

**WARNING**

**Winch and winch bracket are removed as an assembly. Winch and winch bracket weigh 167 lbs (76 kg). Do not lift or move winch bracket without the aid of an assistant and/or a lifting device. Failure to comply may result in injury or death to personnel.**

**NOTE**

The aid of a spreader may be required to install winch bracket and winch.

3. With the aid of an assistant and lifting device, install winch bracket (24) and winch (21) on frame bracket (25) with 12 screws (23) and new locknuts (22).
4. Install two washers (19) and screws (18) on baffle (20) and winch (21).

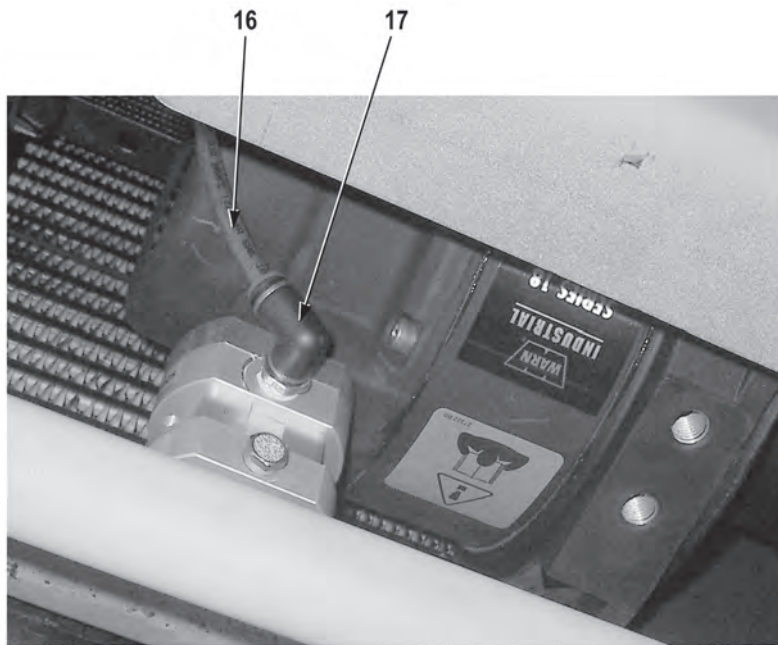

5. Install air line (16) on fitting (17).

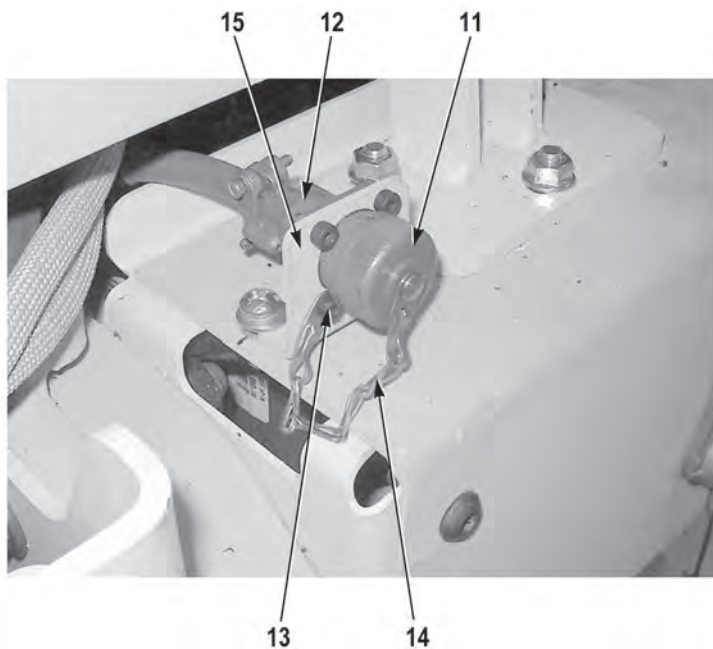
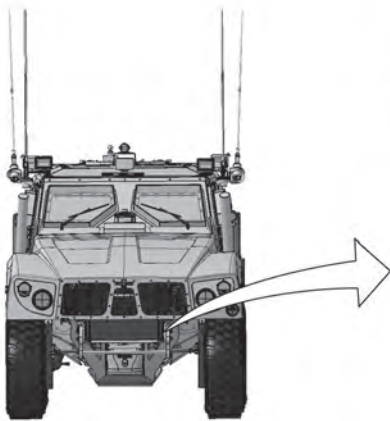

6. Install winch connector (12) and chain (14) on bracket (15) with four screws (13).
7. Install cap (11) on winch connector (12).

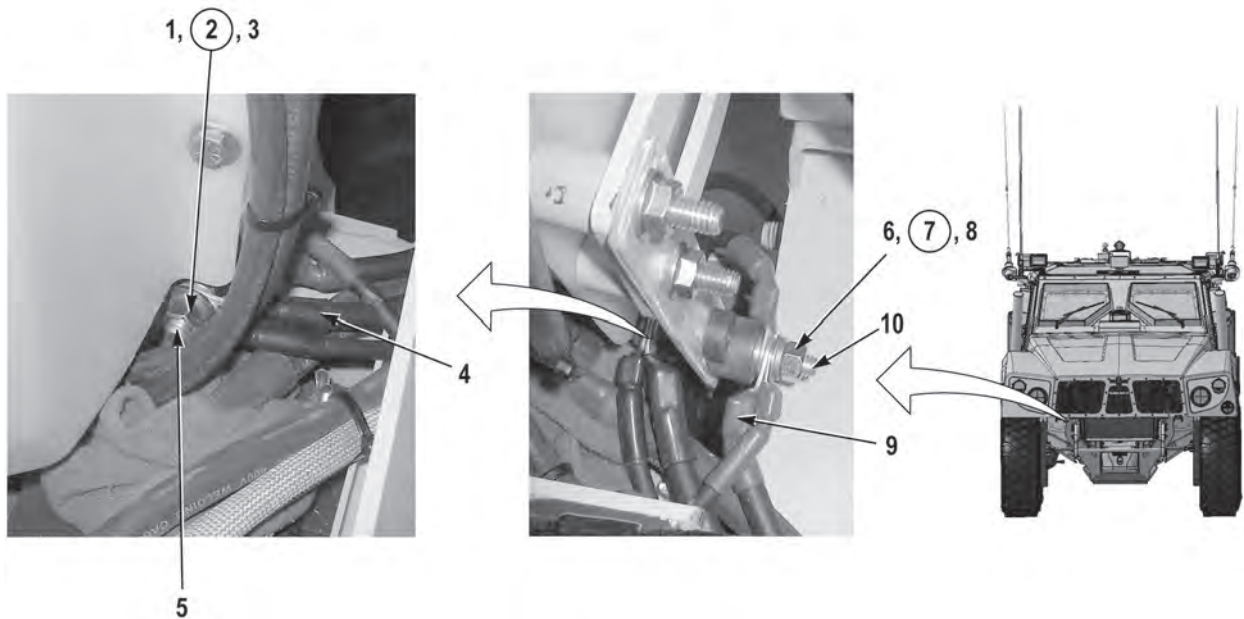

### NOTE

Install cushion clips and cable ties as required.

8. Install positive cable (9) on stud (10) with washer (8), new lockwasher (7), and nut (6).
9. Install negative cable (4) on stud (5) with washer (3), new lockwasher (2), and nut (1).
10. Perform all Follow-On Maintenance tasks.

**END OF TASK**

**END OF WORK PACKAGE**





---

## LOWER STEERING SHAFT REPLACEMENT

---

**Preconditions**

Park vehicle  
 Engine OFF  
 Wheels chocked  
 Front driver side wheel well deflector panel removed (M1240/M1245) (WP 0059)  
 Front driver side wheel well deflector panel removed (M1240A1) WP 0057)

**Tools and Special Tools**

Tool Kit, General Mechanic's: Automotive

**Materials/Parts**

Locknut (Item 1)  
 Locknut (Item 6)  
 Compound, Corrosion Preventive, Ultra Tef-Gel 05SA2

**Follow-On Maintenance**

Install front driver side wheel well deflector panel (M1240/M1245) (WP 0059)  
 Install front driver side wheel well deflector panel (M1240A1) (WP 0057)  
 Remove and stow wheel chocks

---

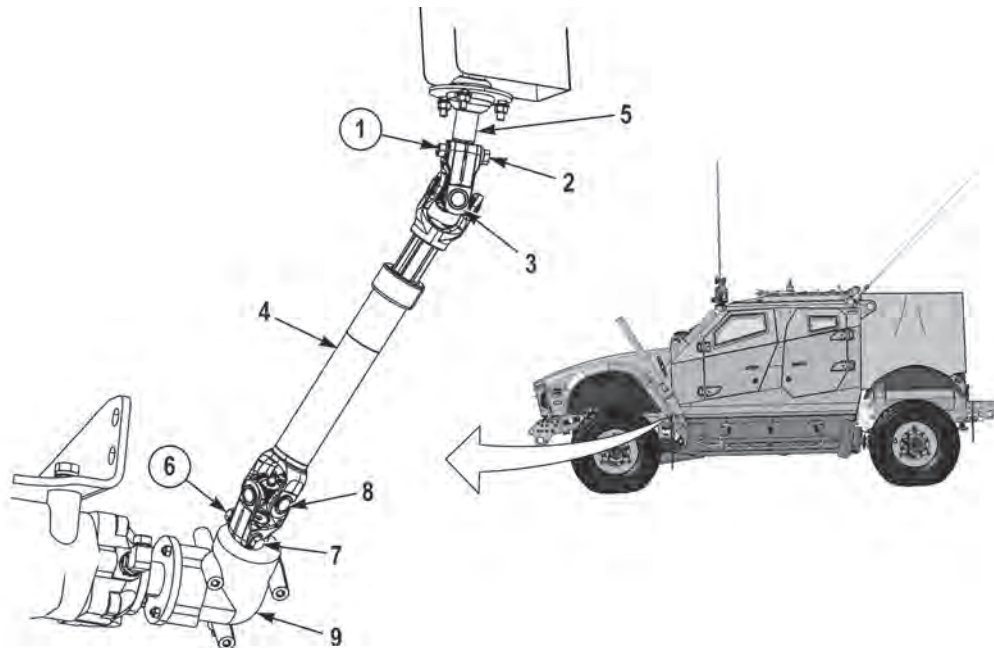
**REMOVAL****NOTE**

Note position of lower steering shaft and steering wheel prior to removal to ensure proper installation.

1. Remove locknut (1) and screw (2) from upper universal joint (3). Discard locknut (1).
2. Remove lower steering shaft (4) from middle steering shaft (5).
3. Remove locknut (6) and screw (7) from lower universal joint (8). Discard locknut (6).
4. Remove lower steering shaft (4) from steering gear mitre (9).

**END OF TASK**

## INSTALLATION

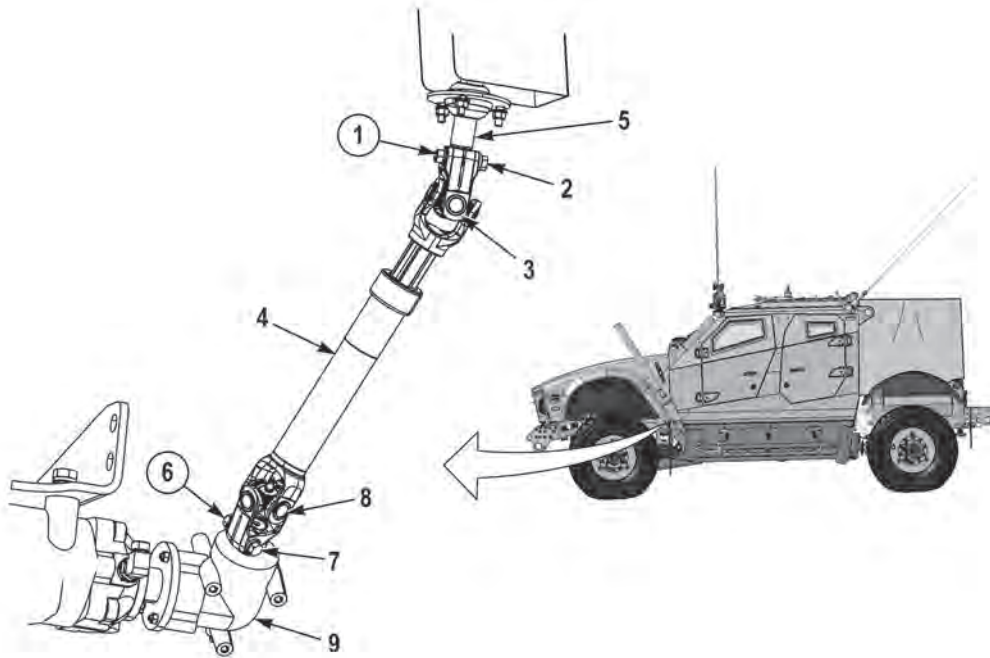

### **WARNING**

Anti-corrosion compound is toxic. Use only in well-ventilated area. Use NIOSH/MSHA-approved respirator with dual organic vapor/mist and particulate cartridge. Do not get in eyes; wear chemical safety goggles and full face shield when using. Avoid contact with skin and wear rubber or plastic, solvent-resistant gloves. In case of contact, remove contaminated clothing and immediately wash area with soap and water. If eyes are contacted, flush eyes with large amounts of water for at least 15 minutes and get immediate medical attention. If swallowed, do not induce vomiting; contact a physician immediately. Failure to comply may result in injury or death to personnel.

1. Apply corrosion preventive compound, Ultra Tef-Gel 05SA2, to splines of middle steering shaft (5) and steering gear mitre (9).

### **NOTE**

Install lower steering shaft as noted prior to removal.

2. Position lower steering shaft (4) on steering gear mitre (9).
3. Install screw (7) and new locknut (6) on lower universal joint (8). Tighten locknut (6) to 35 lb-ft (47 N•m).
4. Position lower steering shaft (4) on middle steering shaft (5).
5. Install screw (2) and new locknut (1) on upper universal joint (3). Tighten locknut (1) to 35 lb-ft (47 N•m).
6. Perform all Follow-On Maintenance tasks.

**END OF TASK**

**END OF WORK PACKAGE**

---

**MIDDLE STEERING SHAFT REPLACEMENT**

---

**Preconditions**

Park vehicle  
 Engine OFF  
 Wheels chocked  
 Driver side belly deflector panel removed  
 (M1240/M1245) (WP 0049)  
 Driver side belly deflector panel removed  
 (M1240A1) (WP 0056)

**Tools and Special Tools**

Tool Kit, General Mechanic's: Automotive

**Materials/Parts**

Lockwasher (2) (Item 2)

**Materials/Parts (continued)**

Lockwasher (2) (Item 6)  
 Locknut (Item 8)  
 Locknut (Item 13)  
 Lockwasher (3) (Item 18)  
 Compound, Corrosion Preventive, Ultra Tef-Gel  
 05SA2

**Follow-On Maintenance**

Install driver side belly deflector panel  
 (M1240/M1245) (WP 0049)  
 Install driver side belly deflector panel (M1240A1)  
 (WP 0056)  
 Remove and stow wheel chocks

---

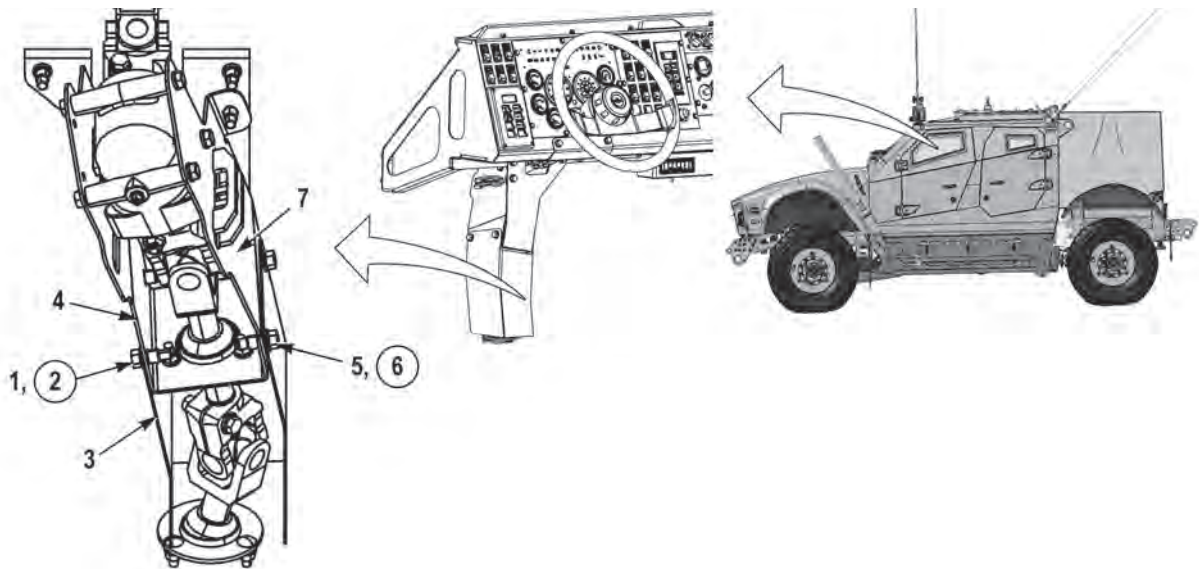
**REMOVAL****NOTE**

- Ensure vehicle wheels are aligned straight ahead before beginning procedures.
  - Do not allow steering wheel to turn once universal joint is removed or misalignment may occur.
  - Note position of middle steering shaft prior to removal to ensure proper installation.
1. Remove two screws (1) and lockwashers (2) from steering shaft bracket (3) and steering column mounting bracket (4). Discard lockwashers (2).
  2. Remove two screws (5), lockwashers (6), and steering shaft bracket (3) from steering column mounting bracket (4) and steering lock weldment bracket (7). Discard lockwashers (6).

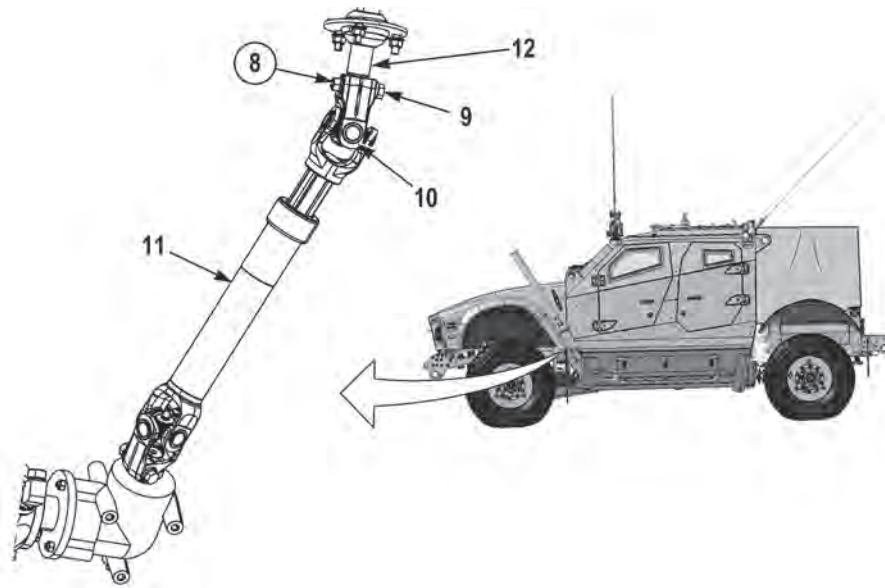

3. Remove locknut (8) and screw (9) from universal joint (10). Discard locknut (8).
4. Remove lower steering shaft (11) from middle steering shaft (12).

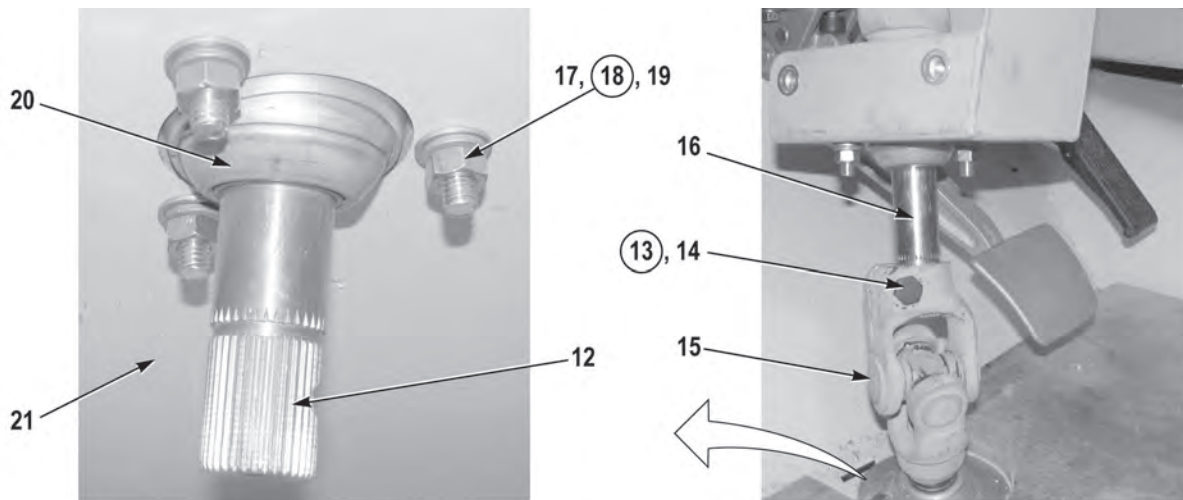

5. Remove locknut (13) and screw (14) from universal joint (15). Discard locknut (13).
6. Remove middle steering shaft (12) from upper steering shaft (16).
7. Remove three nuts (17), lockwashers (18), and screws (19) from center bearing (20) and capsule (21). Discard lockwashers (18).
8. Remove middle steering shaft (12) and center bearing (20) from capsule (21).
9. Remove center bearing (20) from middle steering shaft (12).

**END OF TASK**

---

**INSTALLATION****WARNING**

**Anti-corrosion compound is toxic. Use only in well-ventilated area. Use NIOSH/MSHA-approved respirator with dual organic vapor/mist and particulate cartridge. Do not get in eyes; wear chemical safety goggles and full face shield when using. Avoid contact with skin and wear rubber or plastic, solvent-resistant gloves. In case of contact, remove contaminated clothing and immediately wash area with soap and water. If eyes are contacted, flush eyes with large amounts of water for at least 15 minutes and get immediate medical attention. If swallowed, do not induce vomiting; contact a physician immediately. Failure to comply may result in injury or death to personnel.**

1. Apply corrosion preventive compound, Ultra Tef-Gel 05SA2, on splines of middle steering shaft (12) and upper steering shaft (16).

**NOTE**

- Install middle steering shaft as noted prior to removal.
  - Steering shafts are aligned correctly when spokes on steering wheel are at 3, 6, and 10:00 o'clock position and tires are pointed straight ahead.
2. Install center bearing (20) on middle steering shaft (12).
  3. Install center bearing (20) and middle steering shaft (12) on capsule (21).

**NOTE**

Align center bearing with middle steering shaft before installing screws.

4. Install three screws (19), new lockwashers (18), and nuts (17) on capsule (21) and center bearing (20).
5. Install upper steering shaft (16) on middle steering shaft (12).
6. Install screw (14) and new locknut (13) on universal joint (15). Tighten locknut (13) to 40 lb-ft (54 N•m).
7. Install middle steering shaft (12) on lower steering shaft (11).
8. Install screw (9) and new locknut (8) on universal joint (10). Tighten locknut (8) to 40 lb-ft (54 N•m).

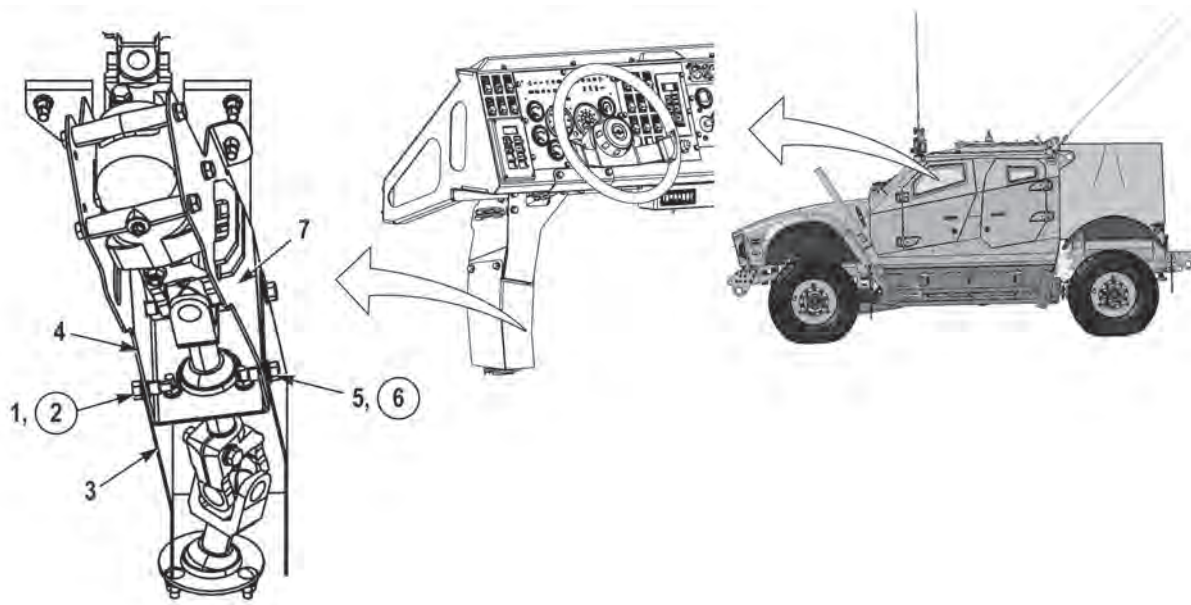

9. Install steering shaft bracket (3) on steering lock weldment bracket (7) and steering column mounting bracket (4) with two new lockwashers (6) and screws (5).
10. Install two new lockwashers (2) and screws (1) on steering column mounting bracket (4) and steering shaft bracket (3).
11. Perform all Follow-On Maintenance tasks.

**END OF TASK**

**END OF WORK PACKAGE**



---

**PITMAN ARM REPLACEMENT**

---

**Preconditions**

Park vehicle  
 Engine OFF  
 Wheels chocked  
 Steering gear tray removed (WP 0285)

**Materials/Parts**

None

**Follow-On Maintenance**

Install steering gear tray (WP 0285)  
 Remove and stow wheel chocks

**Tools and Special Tools**

Adapter, 3/4 F-1/2 m  
 Bit, Hex, 5/8  
 Master Puller Set (From FRS)  
 Tool Kit, General Mechanic's: Automotive  
 Wrench, Torque, 600 ft-lb

---

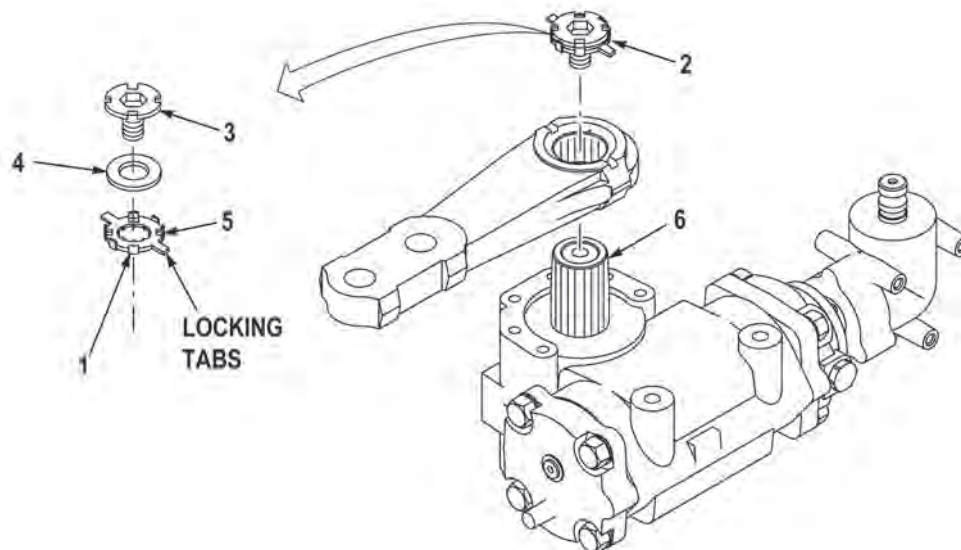
**REMOVAL****CAUTION**

**Do not bend locking tabs in pitman arm slots. Failure to comply may result in damage to equipment.**

**NOTE**

- Both pitman arms are removed the same way. Pitman arm for primary steering gear shown.
  - Match mark position of pitman arm prior to removal to ensure proper installation.
1. Bend two retaining tabs (1) away from tab lock retainer assembly (2).
  2. Remove retainer (3), friction washer (4), and tab washer (5) from steering gear output shaft (6).

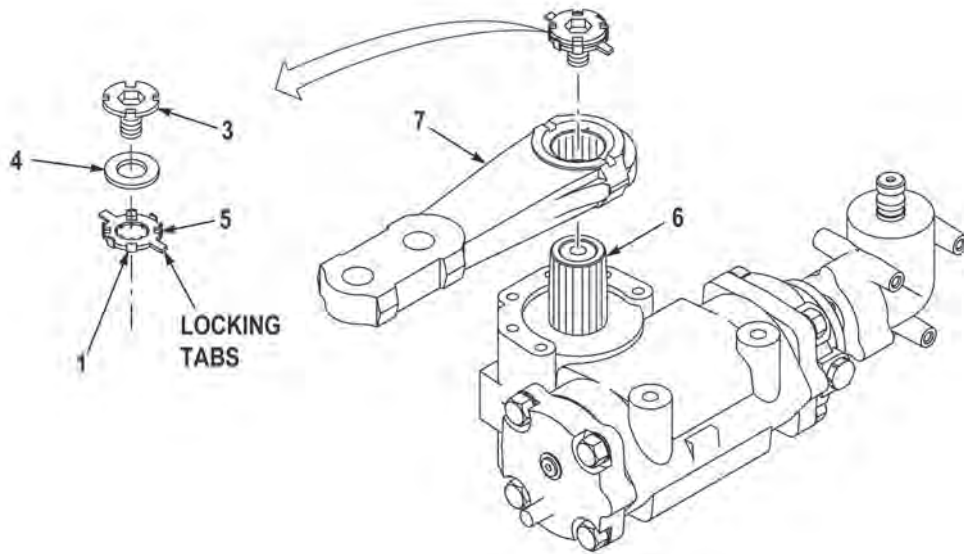

### **WARNING**

Pitman arm will be extremely tight. Do not pound on pitman arm or apply any source of heat, as damage to pitman arm or output shaft can cause an accident at a later date. Failure to comply may result in injury or death to personnel.

### **NOTE**

- Pitman arm has three pads for use of 3-jaw puller.
- Note alignment of timing marks on output shaft and pitman arm prior to removal to ensure proper installation.

3. Remove pitman arm (7) from steering gear output shaft (6).

### **END OF TASK**

### **INSTALLATION**

### **CAUTION**

When installing pitman arm, timing marks on pitman arm and steering output shaft must be aligned as noted prior to removal. Failure to comply may result in damage to equipment.

### **NOTE**

- Both pitman arms are installed the same way. Pitman arm for primary steering gear shown.
- Install pitman arm as noted prior to removal.

1. Align timing mark of pitman arm (7) with timing mark of steering gear output shaft (6).

**WARNING**

**Pitman arm will be extremely tight. Do not pound on pitman arm or apply any source of heat, as damage to pitman arm or output shaft can cause an accident at a later date. Failure to comply may result in injury or death to personnel.**

2. Install pitman arm (7) on steering gear output shaft (6).

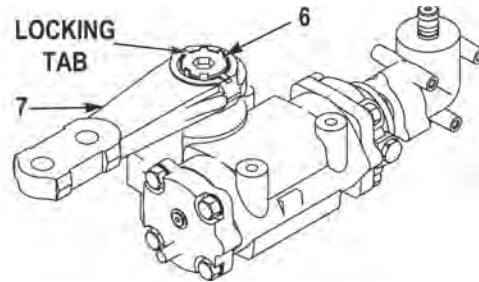

3. Install tab washer (5) on pitman arm (7), aligning two tabs of tab washer (5) with notches in pitman arm (7).
4. Install friction washer (4) and retainer (3) on steering gear output shaft (6).

**WARNING**

**If pitman arm is not tightened to proper specifications, pitman arm could work loose or lose its attachment, causing an accident. If pitman arm is found loose, replace pitman arm and steering gear output shaft. Never weld pitman arm or steering gear output shaft. Failure to comply may result in injury or death to personnel.**

5. Tighten retainer (3) on steering gear output shaft (6). Tighten retainer (3) to 350 lb-ft (475 N•m).
6. After tightening retainer (3), remove retainer (3), friction washer (4), and tab washer (5) from steering gear output shaft (6).

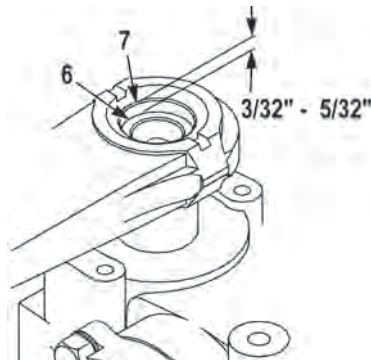
**WARNING**

**If measurement does not meet acceptable minimum or maximum tolerance, pitman arm and steering gear output shaft must be replaced. Failure to take measurement or replace worn part could result in pitman arm becoming loose, causing injury or death to personnel.**

7. Measure distance from end of the output shaft (6) to recessed area of pitman arm (7). The acceptable dimension is 3/32 to 5/32 in. (2.38 to 3.97 mm).

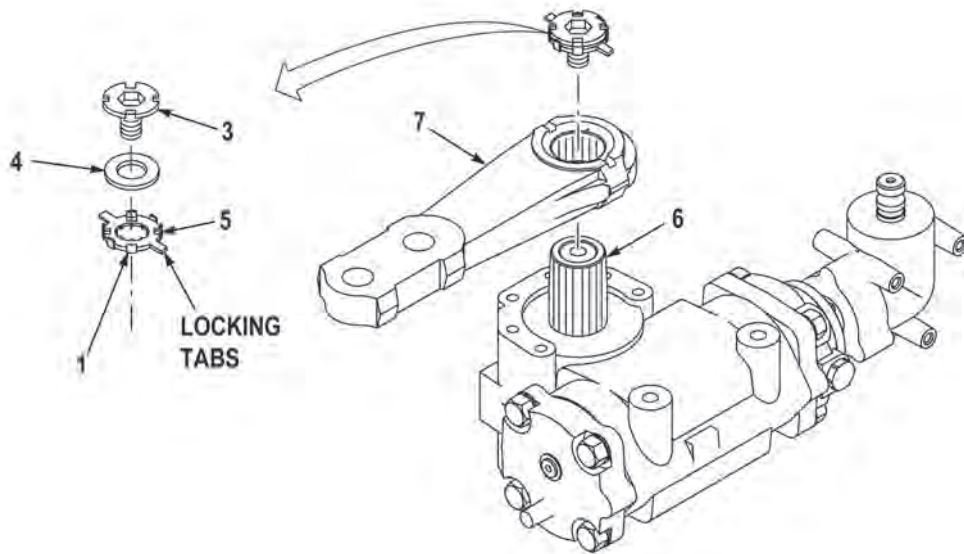

### NOTE

Be sure to align locking tabs of retainer in notches of pitman arm.

8. Install tab washer (5), friction washer (4), and retainer (3) on steering gear output shaft (6). Align locking tabs of tab washer (5) with notches in pitman arm (7) and tighten retainer (3) hand tight.
9. Tighten retainer (3) in steering gear output shaft (6) to 350 lb-ft (475 N•m).

### CAUTION

**If tabs and notches do not line up, tighten beyond specified torque value until two tabs align. Never back off the retainer to align restraining tabs. Failure to comply may result in damage to equipment.**

10. After specified torque value is reached, continue tightening until two retaining tabs (1) of tab washer (5) align with notches in retainer (3).

### WARNING

- **When using a punch and ball peen hammer, always wear safety glasses. Never use a punch that is damaged. Failure to comply may result in injury or death to personnel.**
- **Once tab lock retainer is locked into place, do not retighten. Constant retightening of retainer could cause pitman arm to loosen or retainer to fail, causing an accident at a later date. Failure to comply may result in injury or death to personnel.**

11. Bend retaining tabs (1) into retainer (3).
12. Perform all Follow-On Maintenance tasks.

**END OF TASK**

**END OF WORK PACKAGE**

---

**POWER STEERING FILTER REPLACEMENT**

---

**Preconditions**

Park vehicle  
 Engine OFF  
 Wheels chocked  
 Hood opened and secured  
 Power steering reservoir drained (WP 0278)

**Tools and Special Tools**

Tool Kit, General Mechanic's: Automotive

**Materials/Parts**

O-ring (Item 5)  
 Filter (Item 10)  
 Oil, Hydraulic, OE/HDO 15W40

**Follow-On Maintenance**

Fill power steering reservoir (WP 0278)  
 Close hood and secure  
 Remove and stow wheel chocks

---

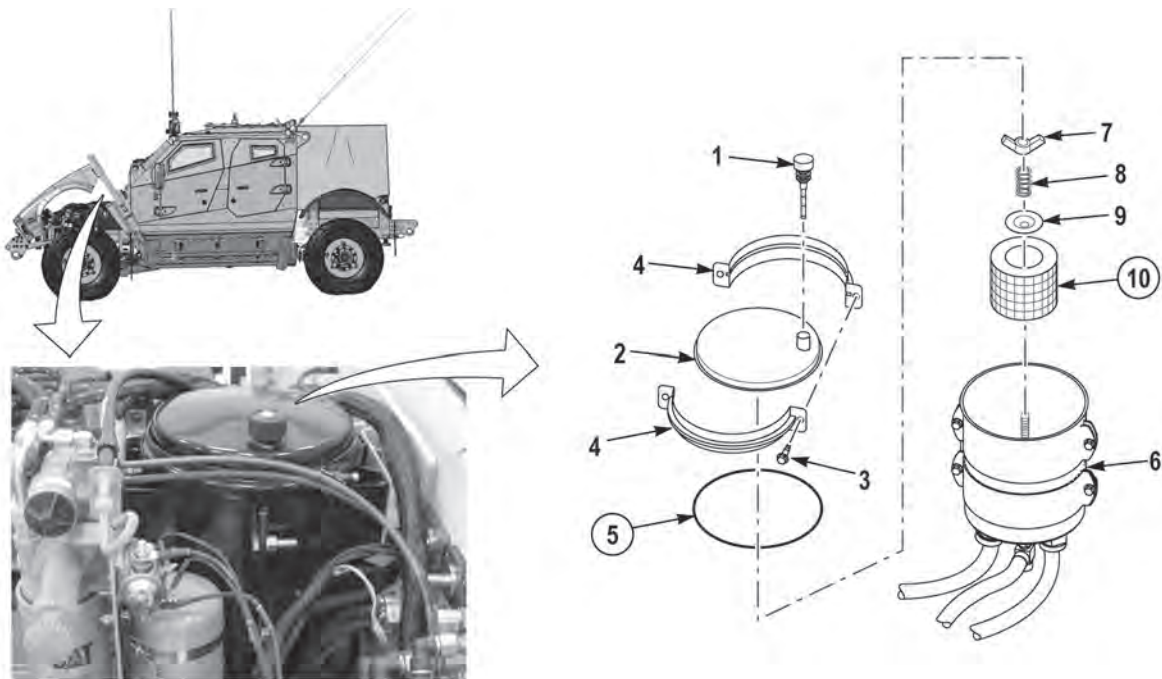
**REMOVAL**

1. Remove dipstick (1) from cover (2).
2. Remove two screws (3), band clamps (4), cover (2), and O-ring (5) from power steering reservoir (6). Discard O-ring (5).
3. Remove nut (7), spring (8), retainer (9), and filter (10) from power steering reservoir (5). Discard filter (10).

**END OF TASK**

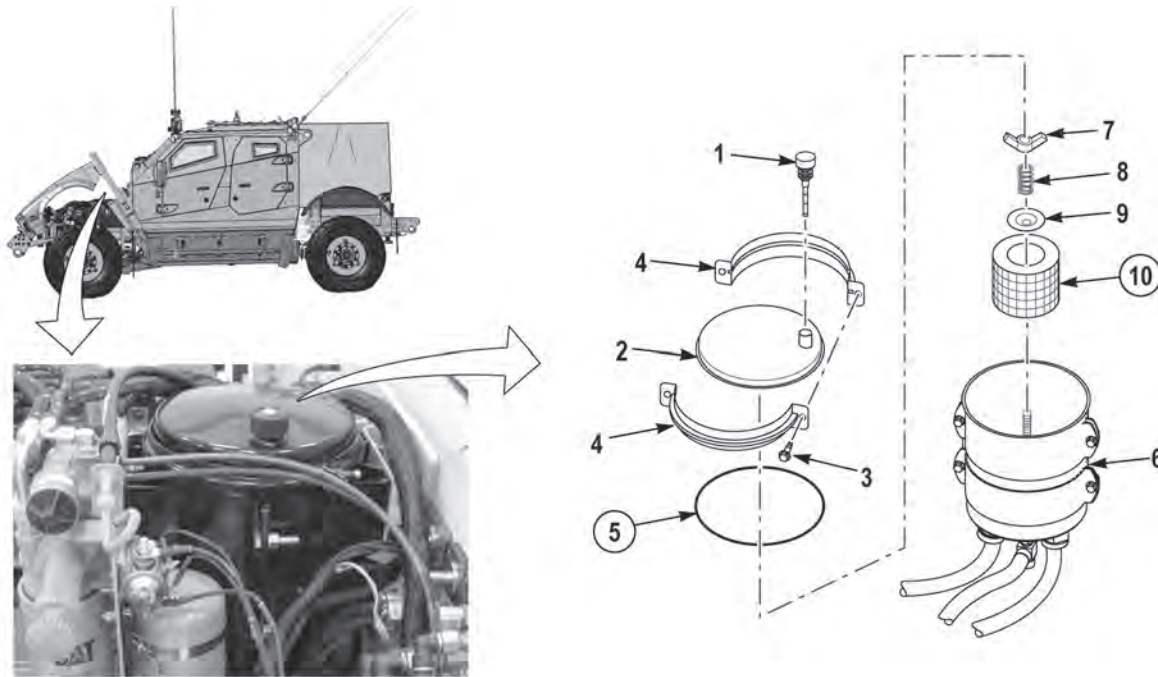
**INSTALLATION**

1. Install new filter (10) in power steering reservoir (5) with retainer (9), spring (8), and nut (7). Tighten nut (7) until it bottoms out.
2. Lightly lubricate new O-ring (5) with clean oil and install O-ring (5), band clamps (4), and cover (2) on power steering reservoir (6) with two screws (3).
3. Install dipstick (1) in cover (2).
4. Perform all Follow-On Maintenance tasks.

**END OF TASK****END OF WORK PACKAGE**



---

**POWER STEERING PUMP REPLACEMENT**

---

**Preconditions**

Park vehicle  
 Engine OFF  
 Wheels chocked  
 Hood opened and secured  
 Batteries disconnected (M1240/M1240A1)  
 (WP 0186)  
 Batteries disconnected (M1245) (WP 0187)  
 Power steering reservoir drained (WP 0278)

**Tools and Special Tools**

Pan, Drain  
 Tool Kit, General Mechanic's: Automotive  
 Wrench, 1-5/8 in.  
 Wrench, 1-1/8 in.

**Materials/Parts**

O-ring (Item 4)  
 O-ring (Item 5)

**Materials/Parts (continued)**

O-ring (Item 6)  
 Gasket (Item 11)  
 O-ring (Item 14)  
 O-ring (Item 15)  
 O-ring (Item 16)  
 Cap and Plug Set  
 Lubrication Oil, Engine  
 Tags, Identification  
 Ties, Cable

**Follow-On Maintenance**

Fill power steering reservoir (WP 0278)  
 Connect batteries (M1240/M1240A1) (WP 0186)  
 Connect batteries (M1245) (WP 0187)  
 Close hood and secure  
 Remove and stow wheel chocks

**REMOVAL****WARNING**

- **Engine must be shut down prior to working on hydraulic components to drop hydraulic pressure to zero. Potential trapped pressure may be present. Loosen couplings slowly to relieve any remaining hydraulic pressure. Failure to comply may result in injury or death to personnel.**
- **Engine components become hot during normal operation. Allow engine to cool completely prior to performing this task. Failure to comply may result in injury to personnel.**

**NOTE**

- Note routing of hoses prior to removal to ensure proper installation.
- Remove cable ties as required.
- Tag and mark hoses and fittings prior to removal to ensure proper installation.
- Cap and plug hoses and fittings upon removal.
- Hydraulic oil may leak from hoses. Position a suitable drain pan under hoses to catch oil.

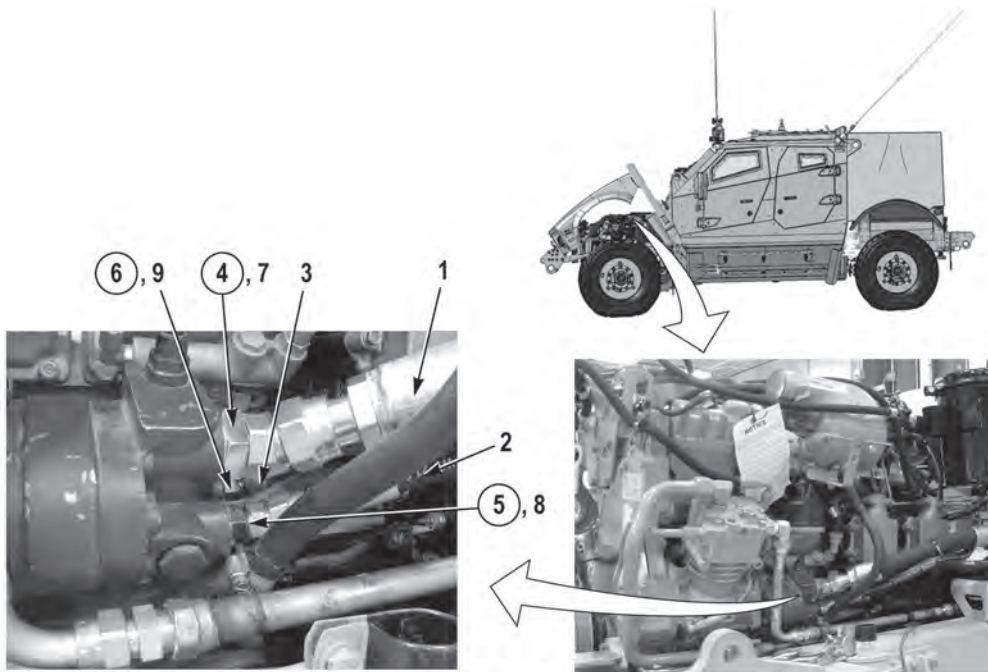

1. Remove three hoses (1, 2, and 3) and three O-rings (4, 5, and 6) from three fittings (7, 8, and 9). Discard O-rings (4, 5, and 6).

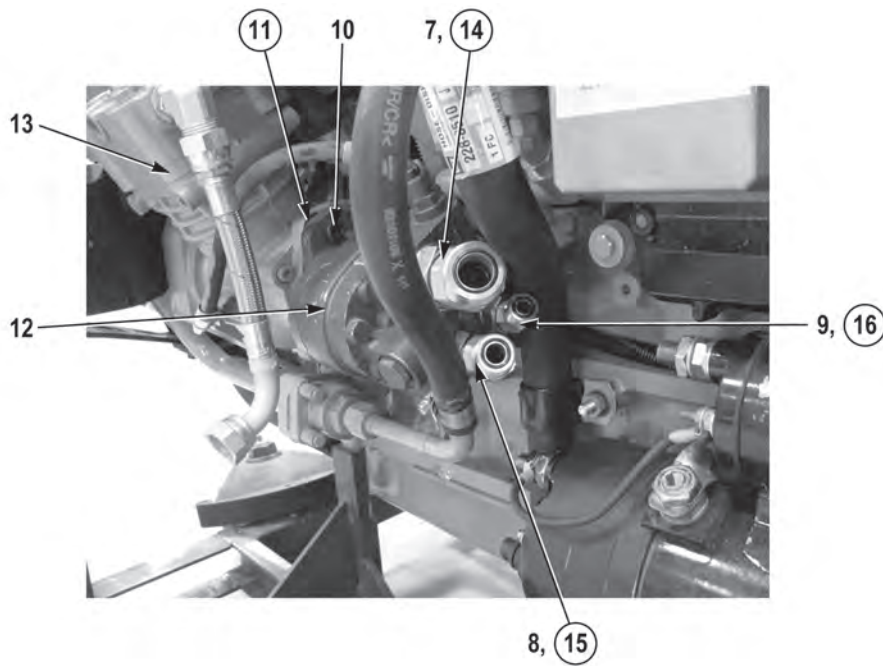

2. Remove two screws (10), gasket (11), and steering pump (12) from air compressor (13). Discard gasket (11).

---

**NOTE**

Note position of fittings prior to removal to ensure proper installation.

3. Remove three fittings (7, 8, and 9) and three O-rings (14, 15, and 16) from steering pump (12). Discard O-rings (14, 15, and 16).

**END OF TASK****INSTALLATION****NOTE**

Install fittings as noted prior to removal.

1. Lightly lubricate three new O-rings (14, 15, and 16) with clean oil and install three O-rings (14, 15, and 16) and three fittings (7, 8, and 9) on steering pump (12).
2. Install new gasket (11) and steering pump (12) on air compressor (13) with two screws (10).

**NOTE**

Install cable ties as required.

3. Lightly lubricate three new O-rings (4, 5, and 6) with clean oil and install three O-rings (4, 5, and 6) and three hoses (1, 2, and 3) on three fittings (7, 8, and 9).
4. Perform all Follow-On Maintenance tasks.

**END OF TASK****END OF WORK PACKAGE**



---

**POWER STEERING RESERVOIR AND BRACKET REPLACEMENT**

---

**Preconditions**

Park vehicle  
 Engine OFF  
 Wheels chocked  
 Hood opened and secured  
 Power steering reservoir drained (WP 0278)

**Tools and Special Tools**

Pan, Drain  
 Tool Kit, General Mechanic's: Automotive  
 Wrench, Combination, 1-5/8 in.

**Materials/Parts**

Locknut (Item 7)  
 Locknut (Item 16)  
 O-ring (Item 30)  
 O-ring (Item 33)  
 O-ring (Item 36)  
 Locknut (4) (Item 40)  
 O-ring (Item 45)

**Materials/Parts (continued)**

O-ring (Item 47)  
 O-ring (Item 49)  
 O-ring (Item 50)  
 O-ring (Item 51)  
 Locknut (8) (Item 52)  
 Lockwasher (7) (Item 56)  
 Cap and Plug Set  
 Oil, Hydraulic, OE/HDO 15W40  
 Tags, Identification  
 Ties, Cable

**Personnel Required**

Two

**Follow-On Maintenance**

Fill power steering reservoir (WP 0278)  
 Close hood and secure  
 Remove and stow wheel chocks

---

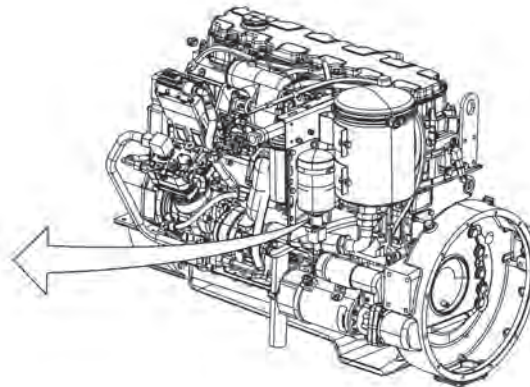
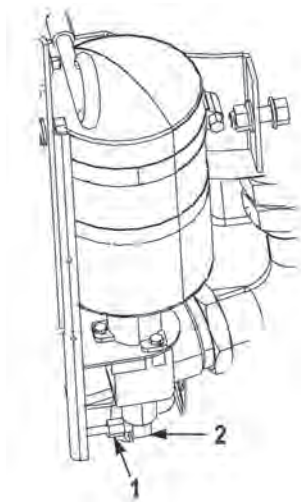
**REMOVAL****NOTE**

Tag and mark hoses prior to removal to ensure proper installation.

1. Remove ether start line (1) from fitting (2).

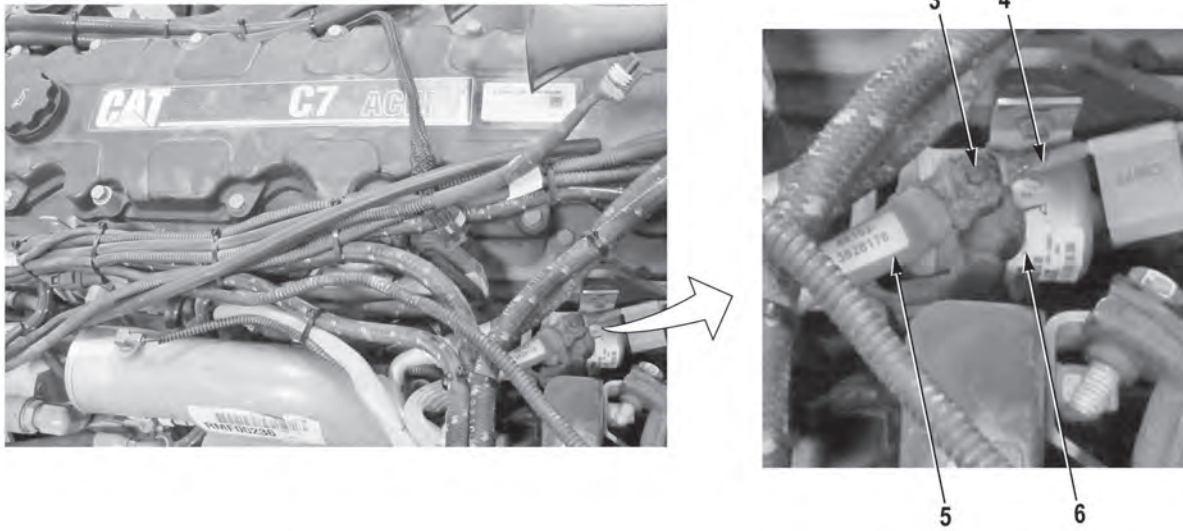

2. Remove nut (3), wire (4), and cable (5) from solenoid (6).

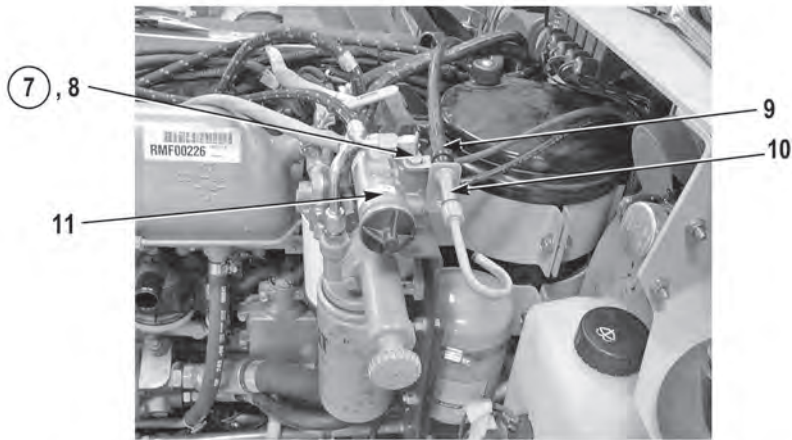

3. Remove locknut (7), screw (8), cushion clip (9), and dipstick (10) from air governor (11). Discard locknut (7).



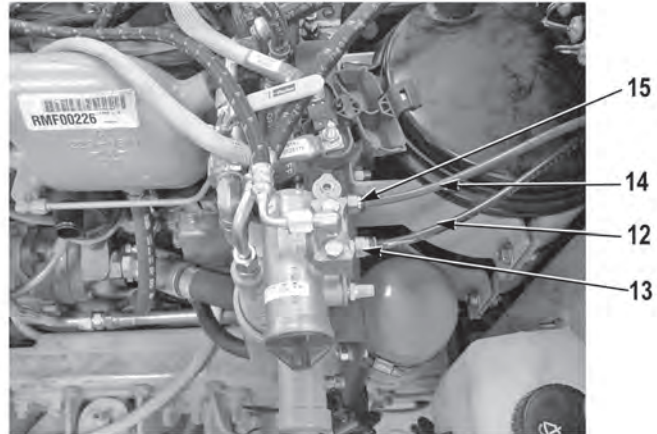

4. Remove air line (12) from fitting (13).
5. Remove air line (14) from fitting (15).

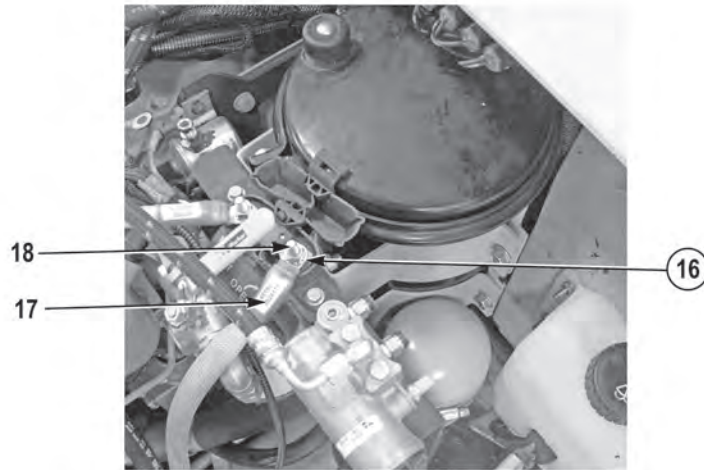

6. Remove locknut (16) and starter cable (17) from stud (18). Discard locknut (16).

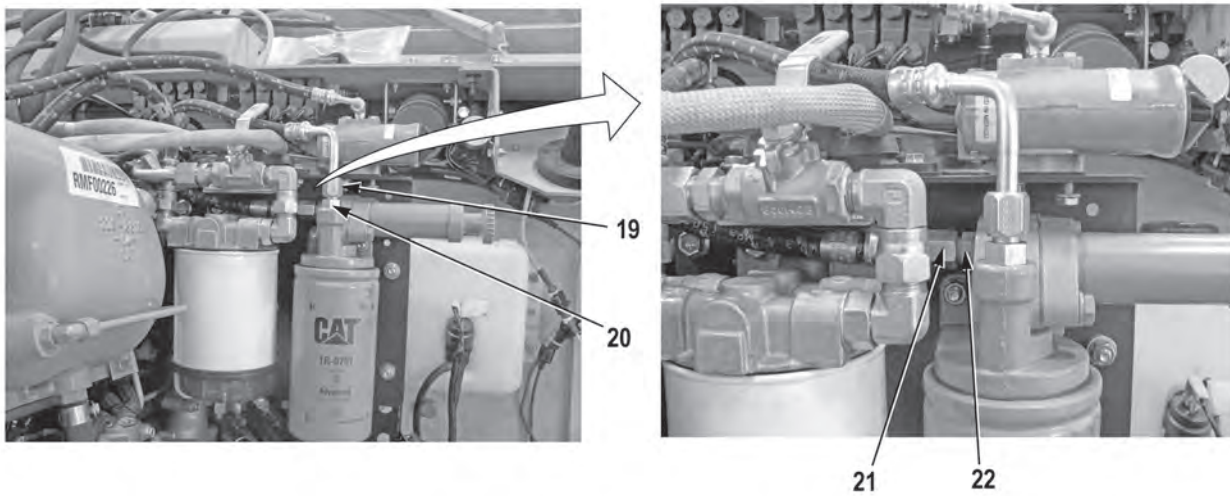
**WARNING**

Fuel is flammable and can explode. Keep fuel away from open flame and keep fire extinguisher within easy reach when working with fuel. Do not work on fuel system when engine is hot. Fuel can be ignited by hot engine. Smoking is prohibited while working with fuel. Failure to comply may result in injury or death to personnel.

7. Remove hose (19) from fitting (20).
8. Remove hose (21) from fitting (22).



9. Disconnect connector (23) from ether start solenoid connector (24).

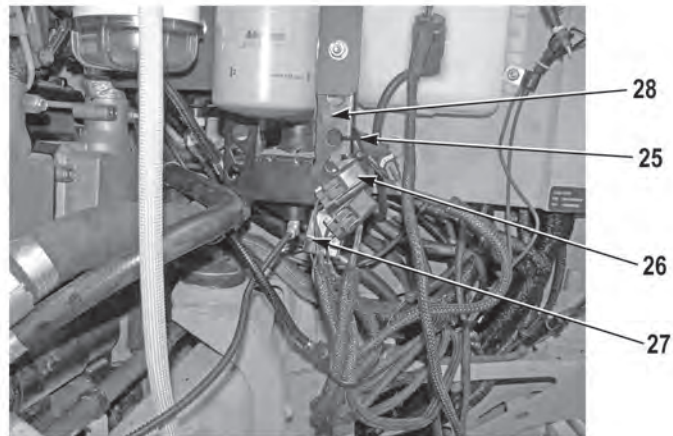

10. Remove five cable ties (25), four fuses (26), and relay (27) from bracket (28). Discard cable ties (25).

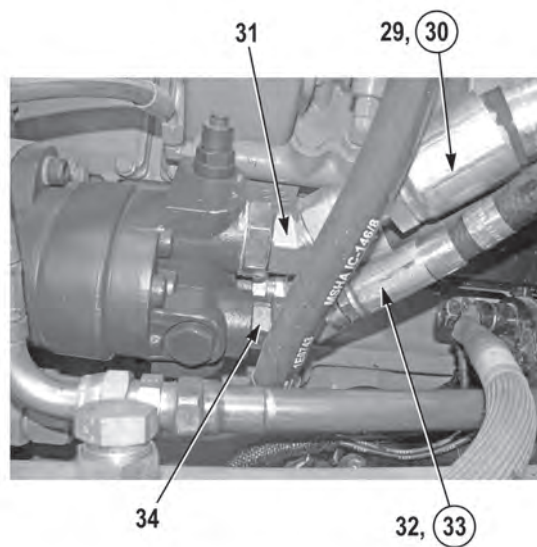

### NOTE

- Hydraulic oil may leak from hoses. Position a suitable drain pan under hoses to catch excess oil.
- Cap and plug hoses and fittings upon removal.
- Air compressor hose may have to be removed for ease of removal.

11. Remove hose (29) and O-ring (30) from fitting (31). Discard O-ring (30).

12. Remove hose (32) and O-ring (33) from fitting (34). Discard O-ring (33).

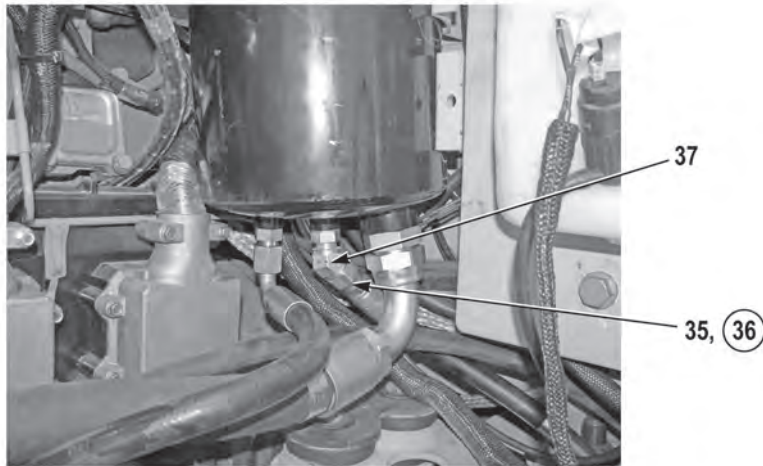

13. Remove hose (35) and O-ring (36) from fitting (37). Discard O-ring (36).

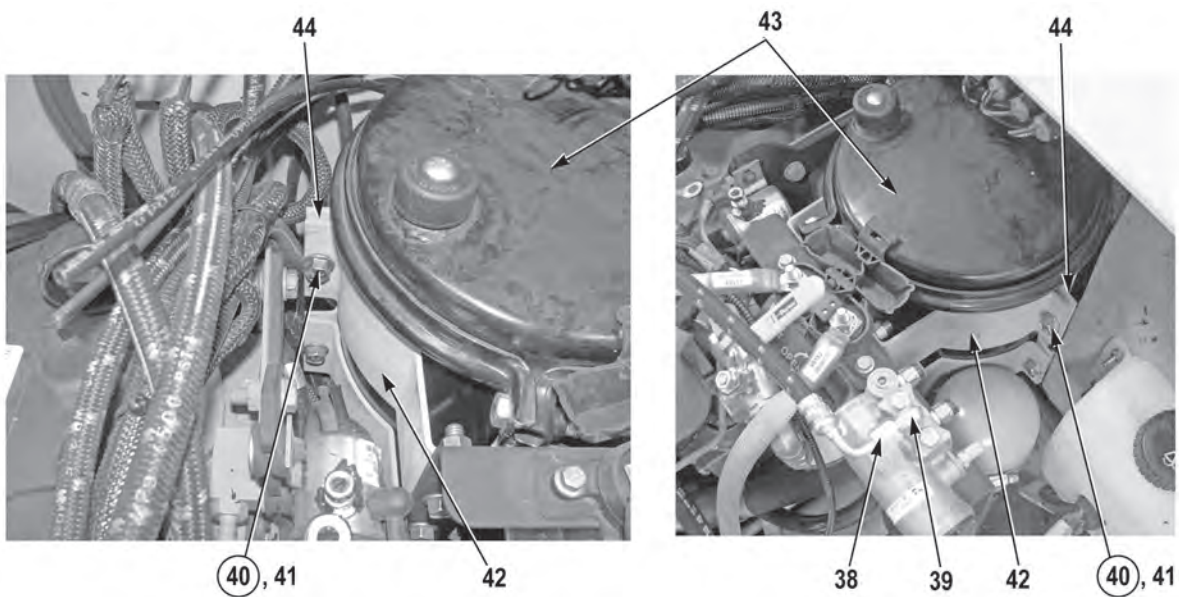

14. Remove fitting (38) from fitting (39).

**CAUTION**

**Support power steering reservoir during front bracket removal. Power steering reservoir could shift when front bracket is removed. Failure to comply may result in damage to equipment.**

**NOTE**

Remove cushion clips as required.

15. Remove four locknuts (40), screws (41), front power steering reservoir bracket assembly (42), and power steering reservoir (43) from rear power steering reservoir bracket (44). Discard locknuts (40).



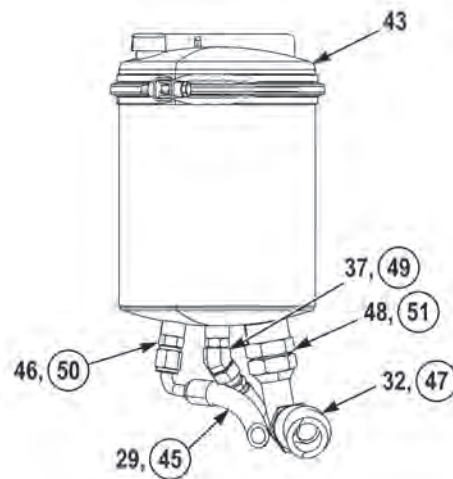

16. Remove hose (29) and O-ring (45) from fitting (46). Discard O-ring (45).
17. Remove hose (32) and O-ring (47) from fitting (48). Discard O-ring (47).
18. Remove three fittings (37, 46, and 48) and O-rings (49, 50, and 51) from power steering reservoir (43). Discard O-rings (49, 50, and 51).

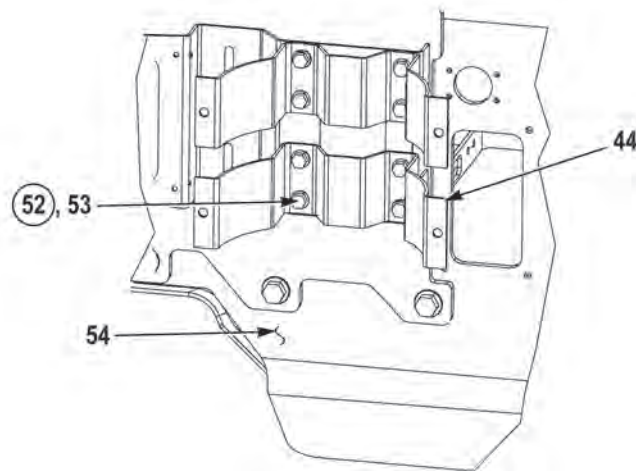

19. Remove eight locknuts (52), screws (53), and rear power steering reservoir bracket (44) from capsule fire wall (54). Discard locknuts (52).

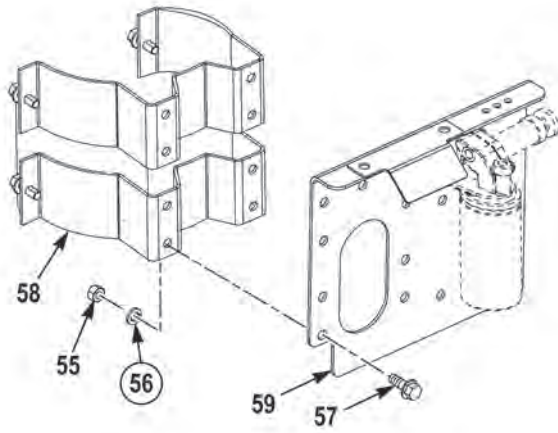

20. Remove seven nuts (55), lockwashers (56), screws (57), and front power steering reservoir bracket (58) from fuel separator bracket (59). Discard lockwashers (56).

#### END OF TASK

#### INSTALLATION

1. Install front power steering reservoir bracket (58) on fuel separator bracket (59) with seven (57), new lockwashers (56), and nuts (55).

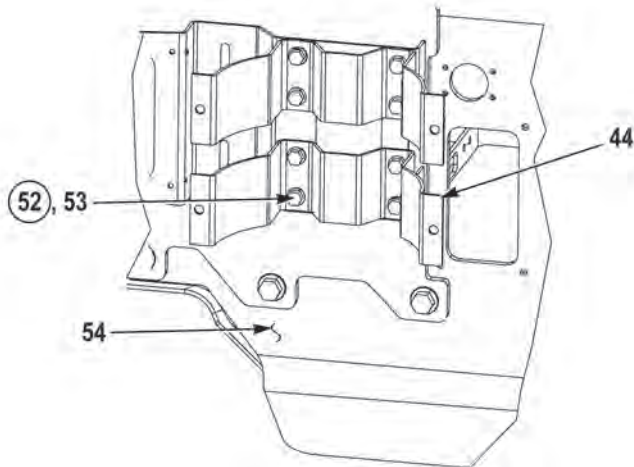

2. Install rear power steering reservoir bracket (44) on capsule firewall (54) with eight screws (53) and new locknuts (52).



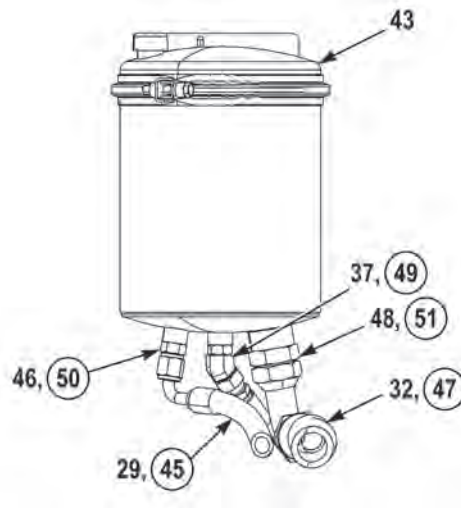

3. Lightly lubricate three new O-rings (49, 50, and 51) with clean oil and install three O-rings (49, 50, and 51) and fittings (37, 46, and 48) on power steering reservoir (43).
4. Lightly lubricate new O-ring (47) with clean oil and install O-ring (47) and hose (32) on fitting (48).
5. Lightly lubricate new O-ring (45) with clean oil and install O-ring (45) and hose (29) on fitting (46).

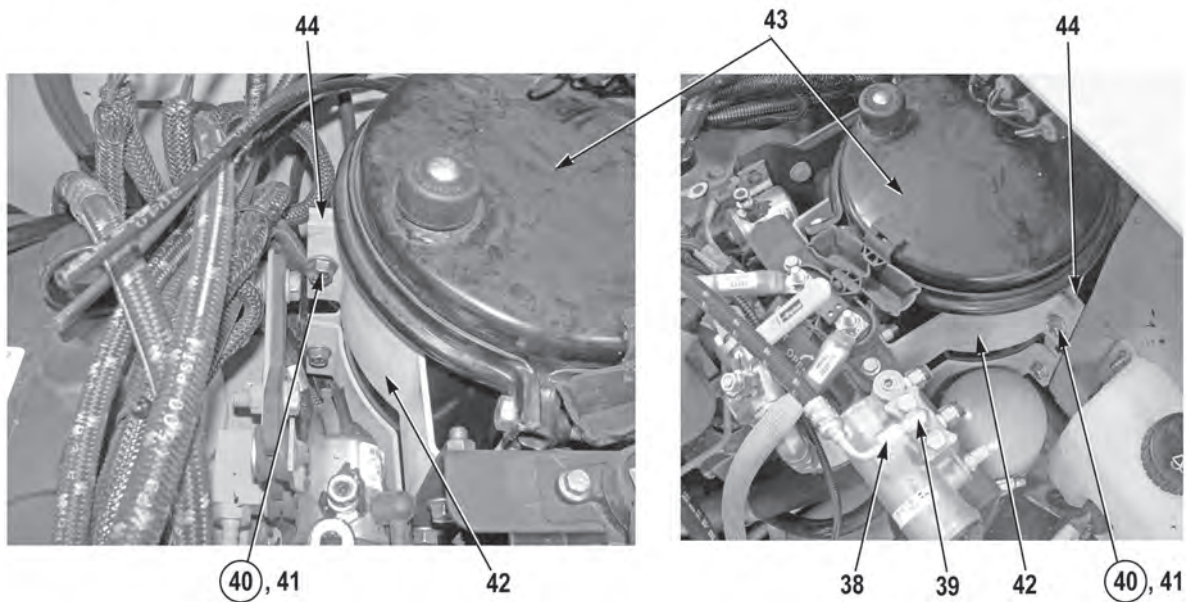

### CAUTION

- **Ensure wires, harnesses, lines, and hoses are clear from back of power steering reservoir during installation. Failure to comply may result in damage to equipment.**
  - **Support power steering reservoir until mounting bracket is secured. Failure to comply may result in damage to equipment.**
6. With the aid of an assistant, install power steering reservoir (43) and front power steering reservoir bracket assembly (42) on rear power steering reservoir bracket (44) with four screws (41) and new locknuts (40).
  7. Install fitting (38) on fitting (39).

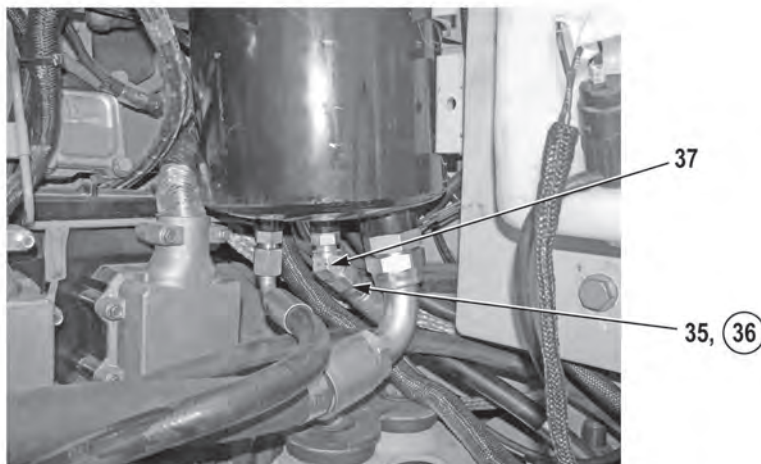

8. Lightly lubricate new O-ring (36) with clean oil and install O-ring (36) and hose (35) on fitting (37).

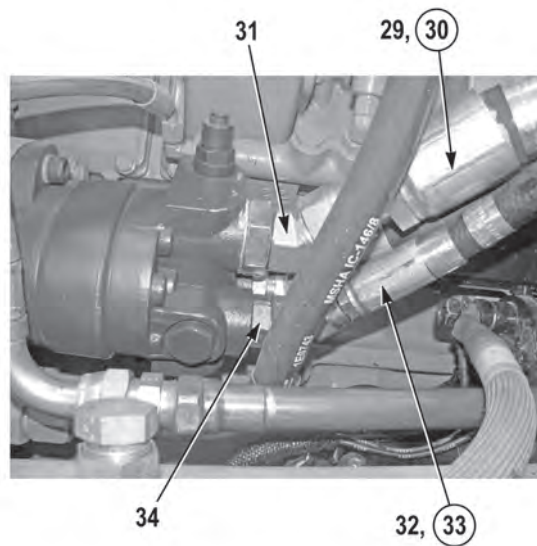

### NOTE

Air compressor hose may have to be removed for ease of installation.

9. Lightly lubricate new O-ring (30) with clean oil and install O-ring (30) and hose (29) on fitting (31).
10. Lightly lubricate new O-ring (33) with clean oil and install O-ring (33) and hose (32) on fitting (34).

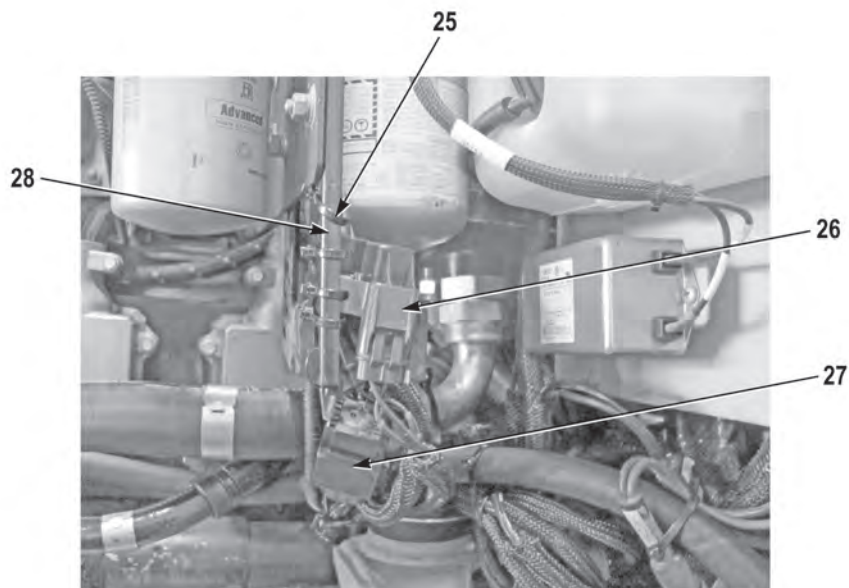

11. Install four fuses (26) and relay (27) on bracket (28) with five new cable ties (25).

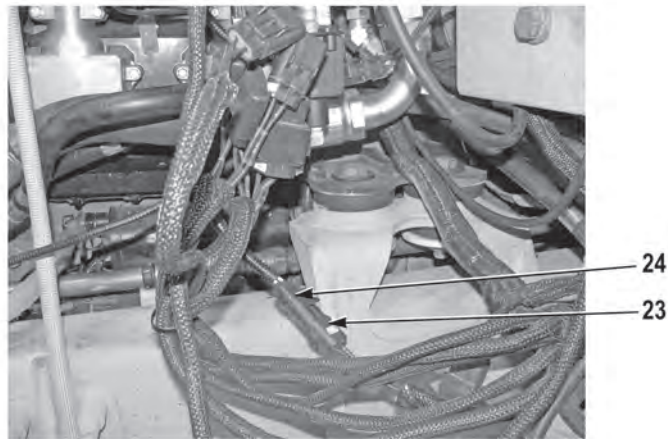

12. Connect ether start solenoid connector (24) to connector (23).

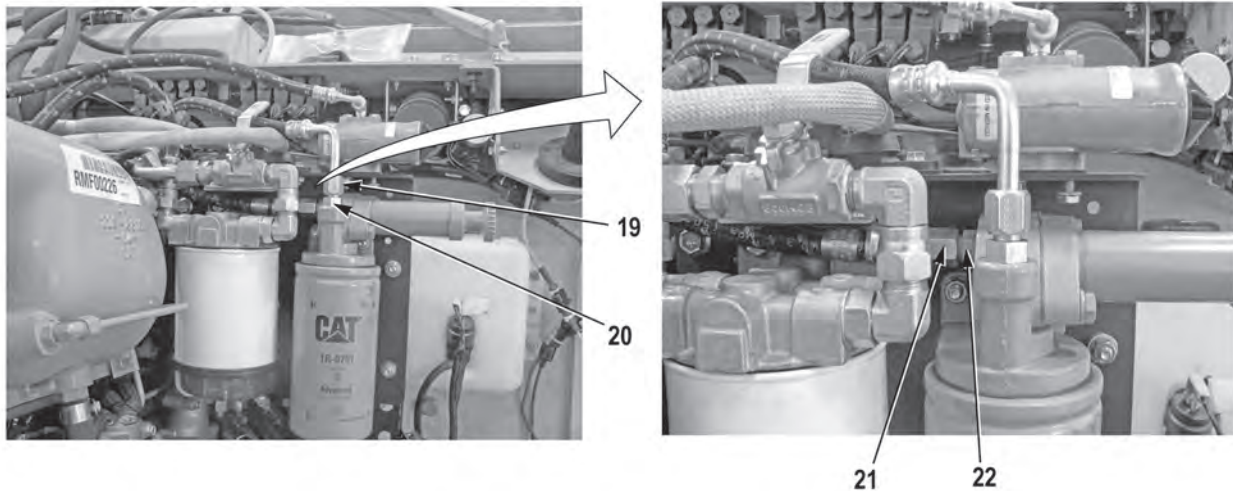

**WARNING**

Fuel is flammable and can explode. Keep fuel away from open flame and keep fire extinguisher within easy reach when working with fuel. Do not work on fuel system when engine is hot. Fuel can be ignited by hot engine. Smoking is prohibited while working with fuel.

13. Install hose (21) on fitting (22).
14. Install hose (19) on fitting (20).



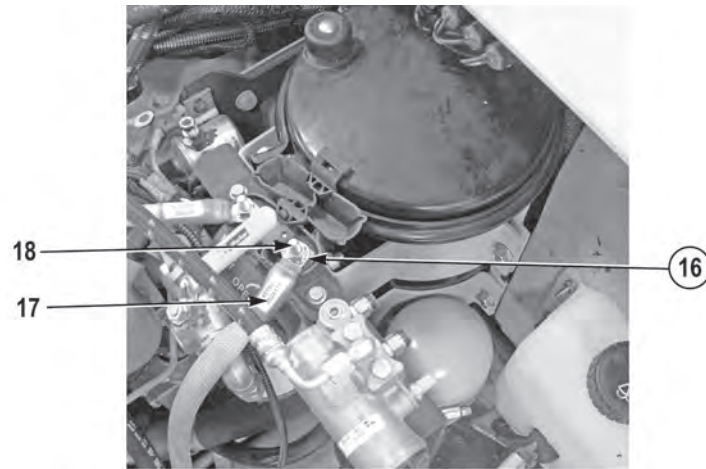

15. Install starter cable (17) on stud (18) with new locknut (16).

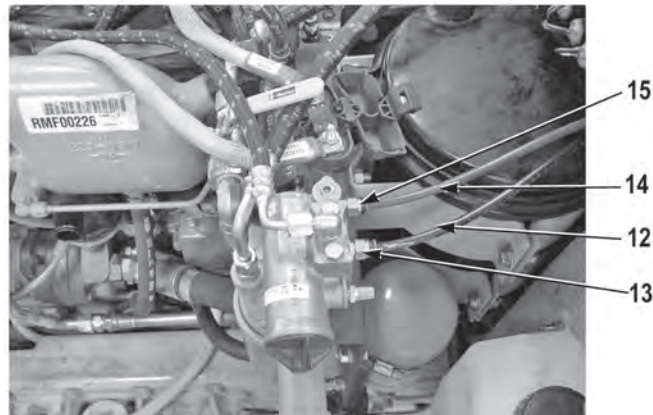

16. Install air line (14) on fitting (15).

17. Install air line (12) on fitting (13).

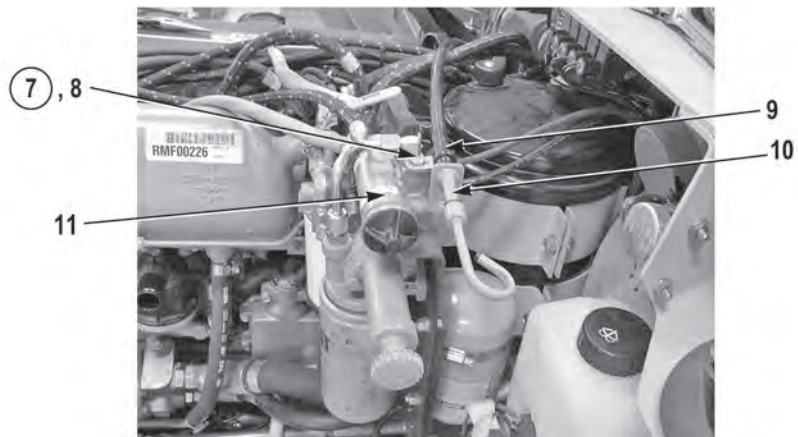

18. Install dipstick (10) and cushion clip (9) on air governor (11) with screw (8) and new locknut (7).

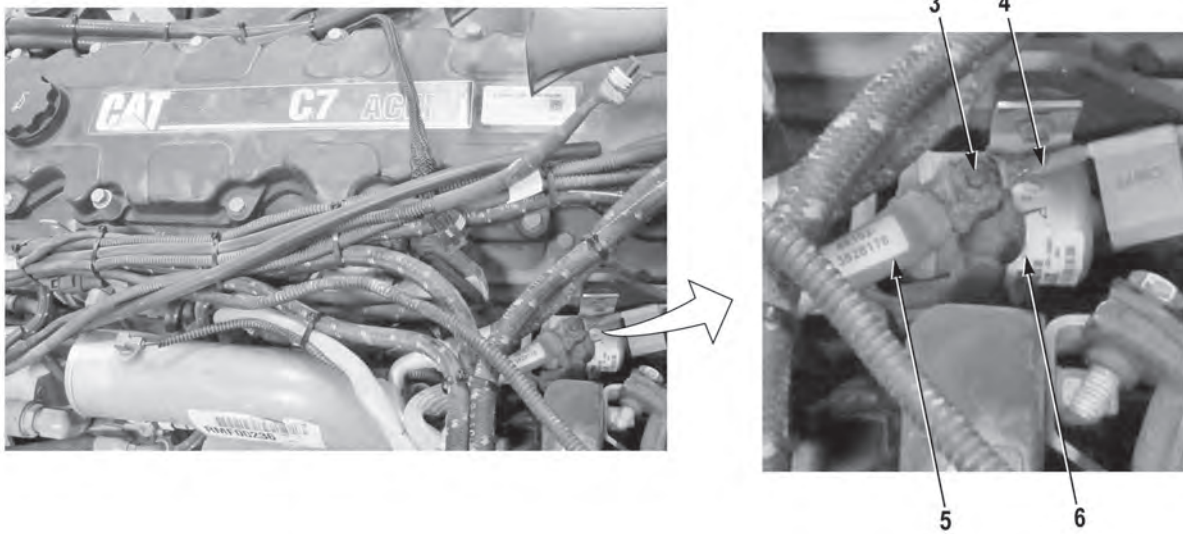

19. Install cable (5) and wire (4) on solenoid (6) with nut (3).

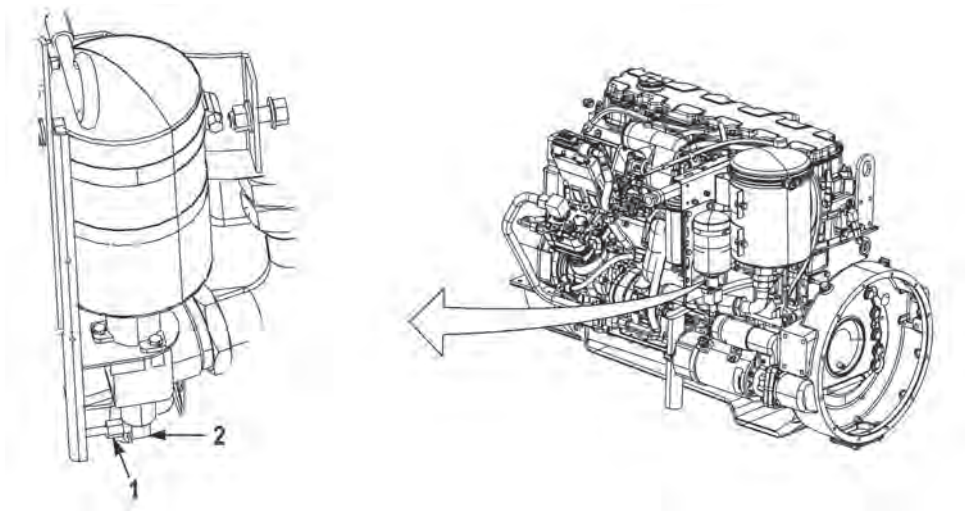

20. Install ether start line (1) on fitting (2).

**END OF TASK**

**END OF WORK PACKAGE**



---

**POWER STEERING RESERVOIR DRAIN/FILL**

---

**Preconditions**

Park vehicle  
 Engine OFF  
 Wheels chocked  
 Hood opened and secured  
 Engine belly deflector panel removed  
 (M1240/M1245) (WP 0050)  
 Engine belly deflector panel removed (M1240A1)  
 (WP 0056)

**Tools and Special Tools**

Funnel  
 Pan, Drain  
 Tool Kit, General Mechanic's: Automotive

**Materials/Parts**

O-ring (Item 3)  
 Cap and Plug Set  
 Oil, Hydraulic, OE/HDO-10  
 Tags, Identification

**Follow-On Maintenance**

Install engine belly deflector panel  
 (M1240/M1245) (WP 0050)  
 Install engine belly deflector panel (M1240A1)  
 (WP 0056)  
 Close hood and secure  
 Remove and stow wheel chocks

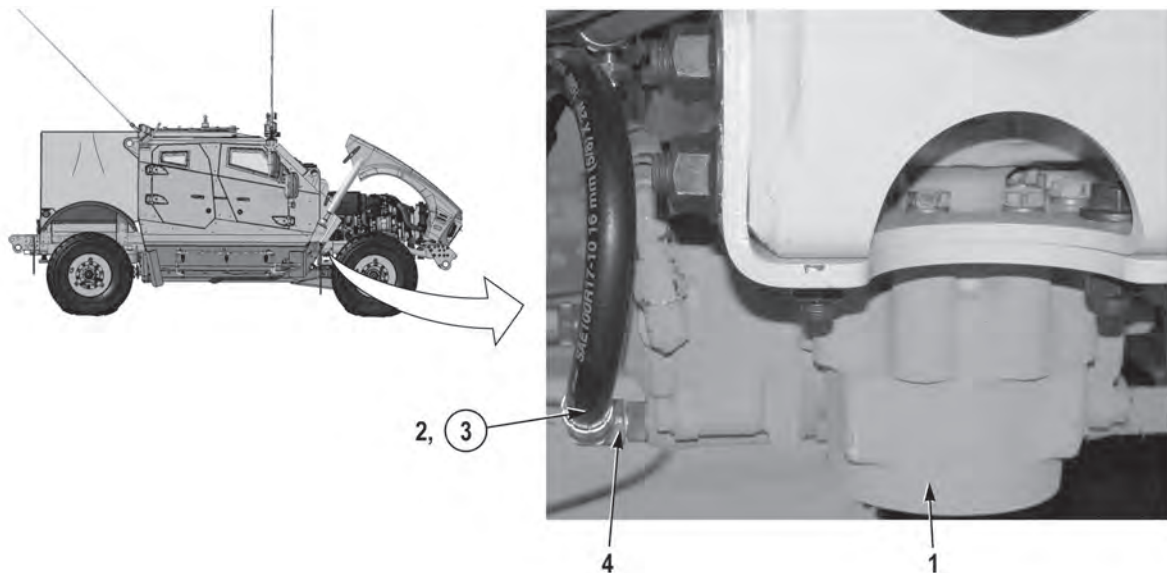
**DRAIN****NOTE**

- Tag and mark hose prior to removal to ensure proper installation.
- Cap and plug hose and fitting when drain is complete.
- Vehicle should be parked on a level surface prior to performing this task.

1. Position suitable drain pan under secondary steering gear (1) and hose (2).
2. Remove hose (2) and O-ring (3) from fitting (4). Discard O-ring (3).

**END OF TASK**

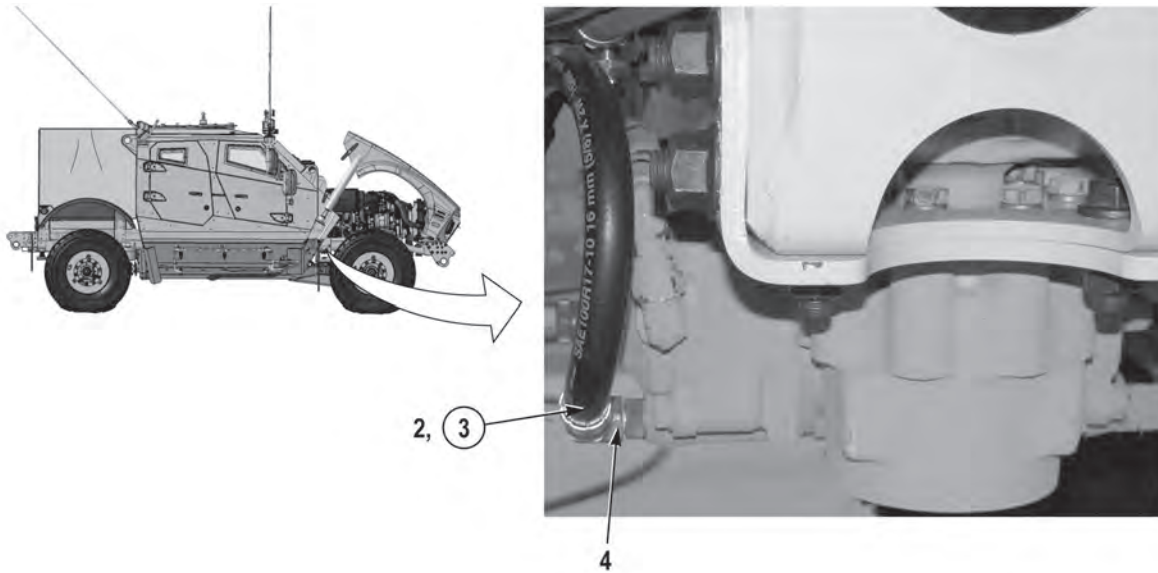
**FILL**

1. Lightly lubricate new O-ring (3) with clean oil and install new O-ring (3) and hose (2) on fitting (4).

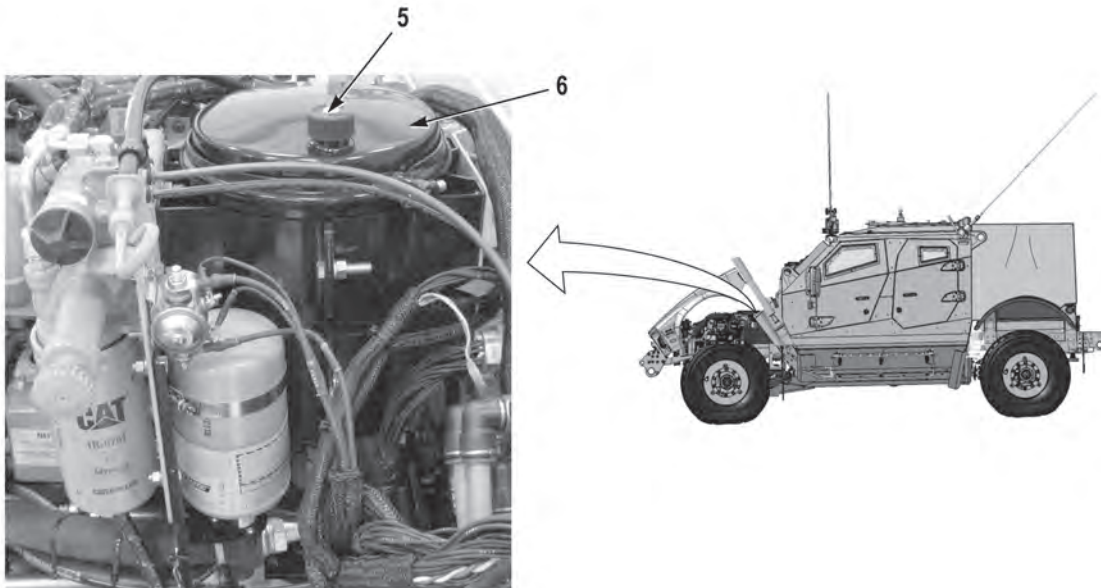

2. Remove dipstick (5) from power steering reservoir (6).

**NOTE**

Power steering reservoir holds approximately seven quarts (6.6 L) of oil.

3. Fill power steering reservoir (6) until oil reaches full mark on cold side of dipstick (5).
4. Check dipstick (5) for oil level, and add oil if required.
5. Install dipstick (5) in power steering reservoir (6).

**NOTE**

- Air may become trapped in steering lines.
  - Perform Steps (6) through (8) to bleed power steering system.
6. Start engine.
  7. Turn wheels to full left and full right until normal steering operation occurs.
  8. Shut off engine.
  9. Perform all Follow-On Maintenance tasks.

**END OF TASK****END OF WORK PACKAGE**



---

**PRIMARY STEERING GEAR REPLACEMENT**

---

**Preconditions**

Park vehicle  
Engine OFF  
Wheels chocked  
Steering gear tray removed (WP 0285)  
Pitman arm removed (WP 0274)

**Tools and Special Tools**

Pan, Drain  
Tool Kit, General Mechanic's: Automotive

**Materials/Parts**

O-ring (Item 2)  
O-ring (Item 4)  
O-ring (Item 7)  
O-ring (Item 9)  
O-ring (Item 11)  
O-ring (Item 13)  
O-ring (Item 15)

**Materials/Parts (continued)**

Lockwasher (2) (Item 17)  
Lockwasher (6) (Item 20)  
Cap and Plug Set  
Compound, Sealing, Flowable Silicone Primer  
Compound, Sealing, Flowable Silicone Sealant  
Lubricating Oil, Engine  
Tags, Identification

**Personnel Required**

Two

**Follow-On Maintenance**

Install pitman arm (WP 0274)  
Install steering gear tray (WP 0285)  
Adjust steering gear relief (WP 0284)  
Remove and stow wheel chocks

## REMOVAL

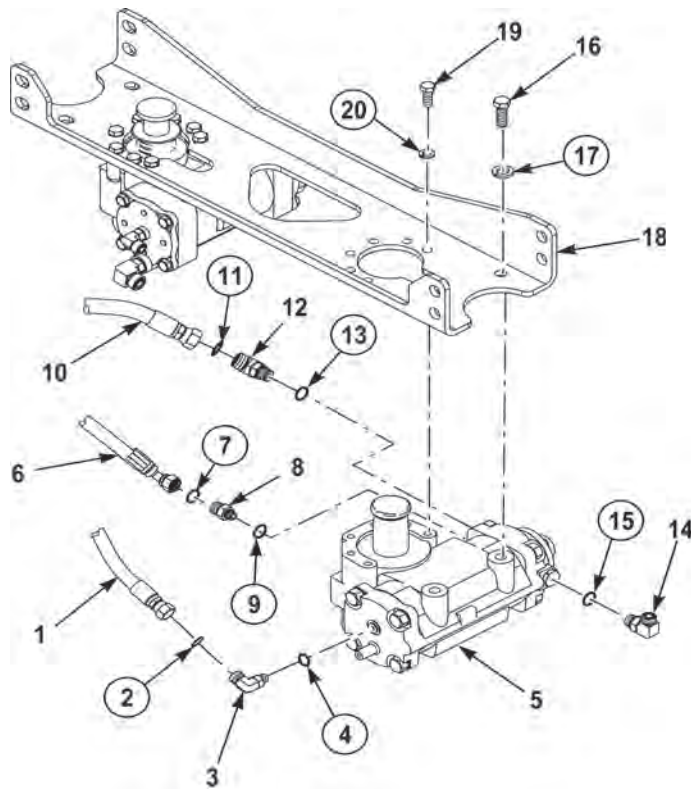
**NOTE**

- Hydraulic oil may leak from hoses. Position a suitable drain pan under hoses to catch excess oil.
- Tag and mark all hoses and fittings prior to removal to ensure proper installation.
- Cap and plug all hoses and fittings upon removal.

1. Remove hose (1), O-ring (2), fitting (3), and O-ring (4) from steering gear (5). Discard O-rings (2 and 4).
2. Remove hose (6), O-ring (7), fitting (8), and O-ring (9) from steering gear (5). Discard O-rings (7 and 9).
3. Remove hose (10), O-ring (11), fitting (12), and O-ring (13) from steering gear (5). Discard O-rings (11 and 13).
4. Remove fitting (14) and O-ring (15) from steering gear (5). Discard O-ring (15).



**WARNING**

**Primary steering gear weighs 75 lbs (34 kg). Do not lift or move primary steering gear without the aid of an assistant. Failure to comply may result in injury to personnel.**

5. With the aid of an assistant, remove two screws (16), lockwashers (17), from steering gear (5) and steering gear tray (18). Discard lockwashers (17).
6. With the aid of an assistant, remove six screws (19), lockwashers (20), and steering gear (5) from steering gear tray (18). Discard lockwashers (20).

**END OF TASK****INSTALLATION****WARNING**

**Primary steering gear weighs 75 lbs (34 kg). Do not lift or move primary steering gear without the aid of an assistant. Failure to comply may result in injury to personnel.**

**NOTE**

Tighten screws in a criss-cross pattern.

1. With the aid of an assistant, install steering gear (5) on steering gear tray (18) with six new lockwashers (20) and screws (19).
2. With the aid of an assistant, install steering gear (5) on steering gear tray (18) with two new lockwashers (17) and screws (16).
3. Lightly lubricate seven new O-rings (2, 4, 7, 9, 11, 13, and 15) with clean oil.

**NOTE**

Install fittings and hoses as noted prior to removal.

4. Install O-ring (15) and fitting (14) on steering gear (5).
5. Install O-ring (13), fitting (12), O-ring (11), and hose (10) on steering gear (5).
6. Install O-ring (9), fitting (8), O-ring (7), and hose (6) on steering gear (5).
7. Install O-ring (4), fitting (3), O-ring (2), and hose (1) on steering gear (5).

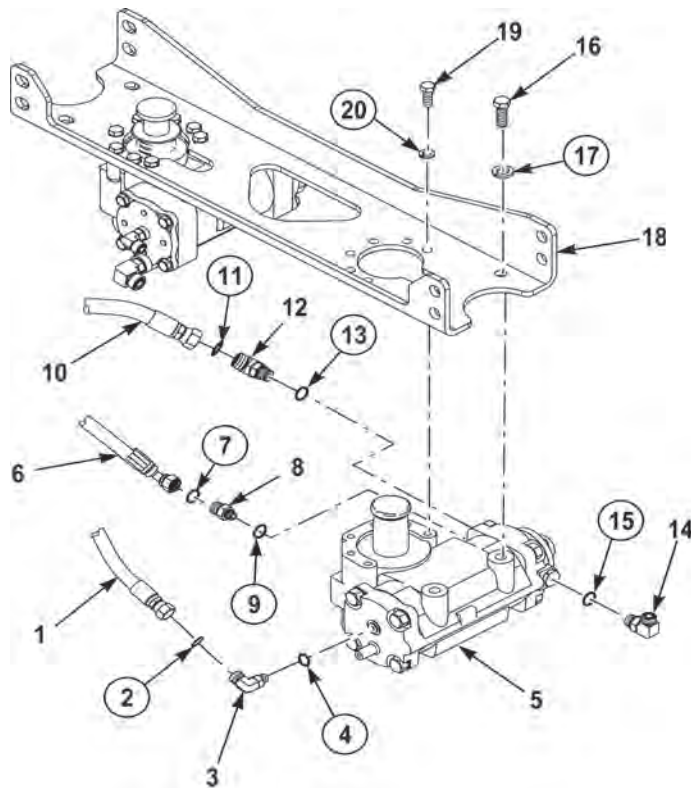

### **WARNING**

Adhesives, solvents, and sealing compounds can burn easily, can give off harmful vapors, and are harmful to skin and clothing. To avoid injury or death, keep away from open fire and use in well-ventilated area. If adhesive, solvent, or sealing compound gets on skin or clothing, wash immediately with soap and water. Failure to comply may result in injury or death to personnel.

8. Apply primer, Dow Corning 1204, and sealing compound, Dow Corning 3140, to fittings on three hoses (10, 6, and 1) and fittings (12, 8, and 3).
9. Perform all Follow-On Maintenance tasks.

**END OF TASK**

**END OF WORK PACKAGE**

---

**SECONDARY STEERING GEAR REPLACEMENT**

---

**Preconditions**

Park vehicle  
 Engine OFF  
 Wheels chocked  
 Steering gear tray removed (WP 0285)  
 Pitman arm removed (WP 0274)

**Tools and Special Tools**

Pan, Drain  
 Tool Kit, General Mechanic's: Automotive

**Materials/Parts**

O-ring (Item 2)  
 O-ring (Item 4)  
 O-ring (Item 7)  
 O-ring (Item 9)  
 O-ring (Item 11)  
 O-ring (Item 13)

**Materials/Parts (Continued)**

O-ring (Item 15)  
 Lockwasher (8) (Item 19)  
 Cap and Plug Set  
 Compound, Sealing, Flowable Silicone Primer,  
 Dow Corning 1204  
 Compound, Sealing, Flowable Silicone Sealant,  
 Dow Corning 3140  
 Lubricating Oil, Engine  
 Tags, Identification

**Personnel Required**

Two

**Follow-On Maintenance**

Install steering gear tray (WP 0285)  
 Install pitman arm (WP 0274)  
 Remove and stow wheel chocks

---

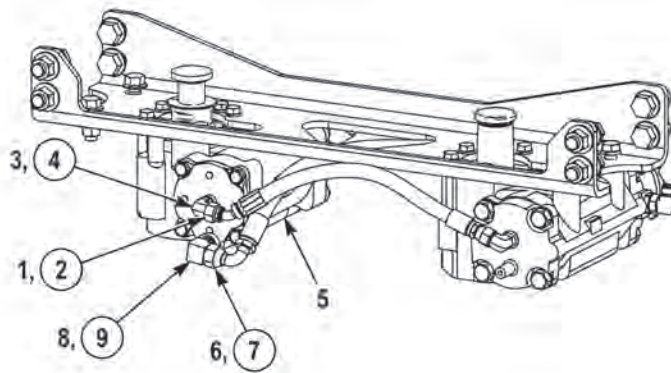
**REMOVAL****NOTE**

- Hydraulic oil may leak from hoses. Position a suitable drain pan under hoses to catch excess oil.
  - Tag and mark hoses prior to removal to ensure proper installation.
  - Cap and plug hoses upon removal.
1. Remove hose (1), O-ring (2), fitting (3), and O-ring (4) from steering gear (5). Discard O-rings (2 and 4).
  2. Remove hose (6), O-ring (7), fitting (8), and O-ring (9) from steering gear (5). Discard O-rings (7 and 9).

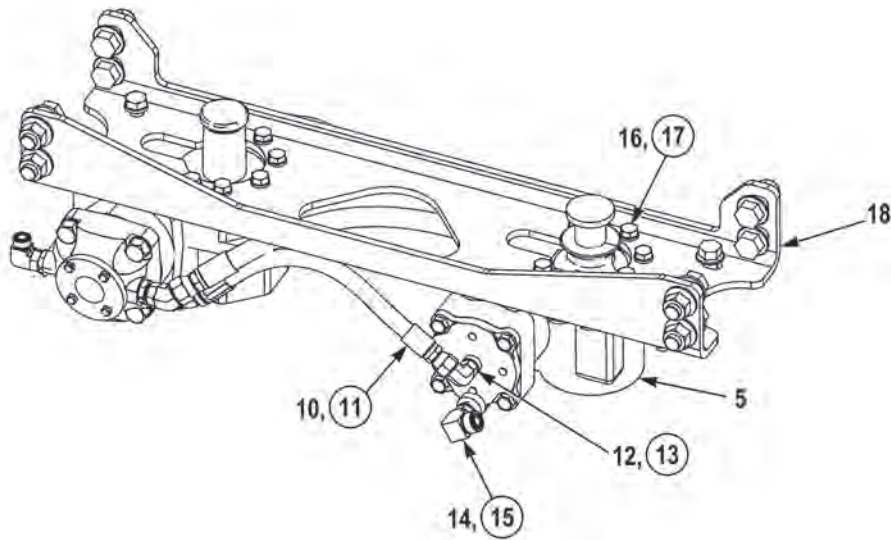

3. Remove hose (10), O-ring (11), fitting (12), and O-ring (13) from steering gear (5). Discard O-rings (11 and 13).
4. Remove fitting (14) and O-ring (15) from steering gear (5). Discard O-ring (15).

### **WARNING**

**Secondary steering gear weighs 70 lbs (32 kg). Do not lift or move secondary steering gear without the aid of an assistant. Failure to comply may result in injury to personnel.**

5. With the aid of an assistant, remove eight screws (16), lockwashers (17), and steering gear (5) from steering gear tray (18). Discard lockwashers (17).

### **END OF TASK**

### **INSTALLATION**

### **WARNING**

**Secondary steering gear weighs 70 lbs (32 kg). Do not lift or move secondary steering gear without the aid of an assistant. Failure to comply may result in injury to personnel.**

### **NOTE**

Tighten screws in a criss-cross pattern.

1. With the aid of an assistant, install steering gear (5) on steering gear tray (18) with eight new lockwashers (17) and screws (16).
2. Lightly lubricate seven new O-rings (15, 13, 11, 9, 7, 4, and 2) with clean oil.
3. Install O-ring (15) and fitting (14) on steering gear (5).
4. Install O-ring (13) and fitting (12), O-ring (11), and hose (10) on steering gear (5).

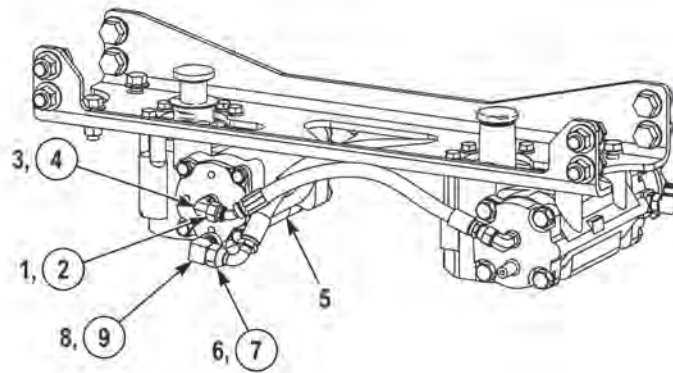

5. Install O-ring (9), fitting (8), O-ring (7), and hose (6) on steering gear (5).
6. Install O-ring (4), fitting (3), O-ring (2), and hose (1) on steering gear (5).

### **WARNING**

**Adhesives, solvents, and sealing compounds can burn easily, can give off harmful vapors, and are harmful to skin and clothing. To avoid injury or death, keep away from open fire and use in well-ventilated area. If adhesive, solvent, or sealing compound gets on skin or clothing, wash immediately with soap and water. Failure to comply may result in injury or death to personnel.**

7. Apply primer, Dow Corning 1204, and sealing compound, Dow Corning 3140, to three hoses (10, 6, and 1) and four fittings (14, 12, 8, and 3).
8. Perform all Follow-On Maintenance tasks.

**END OF TASK**

**END OF WORK PACKAGE**





---

**STEERING ARM REPLACEMENT**

---

**Preconditions**

Park vehicle  
 Engine OFF  
 Wheels chocked  
 Wheel/tire removed (TM 9-2355-335-10)  
 Toe control link removed (WP 0288)  
 Upper control arm removed (WP 0099)

**Tools and Special Tools**

Jack, Floor  
 Socket, 1-1/8 in.  
 Tool Kit, General Mechanic's: Automotive  
 Wrench, Torque, 600 ft-lb

**Materials/Parts**

Lockwasher (2) (Item 5)  
 Lockwasher (2) (Item 10)  
 Cap and Plug Set  
 Compound, Sealing, Loctite 242  
 Compound, Sealing, Torque (F-1000)  
 Ties, Cable

**Follow-On Maintenance**

Install upper control arm (WP 0099)  
 Install toe control link (WP 0288)  
 Install wheel/tire (TM 9-2355-335-10)  
 Remove and stow wheel chocks

---

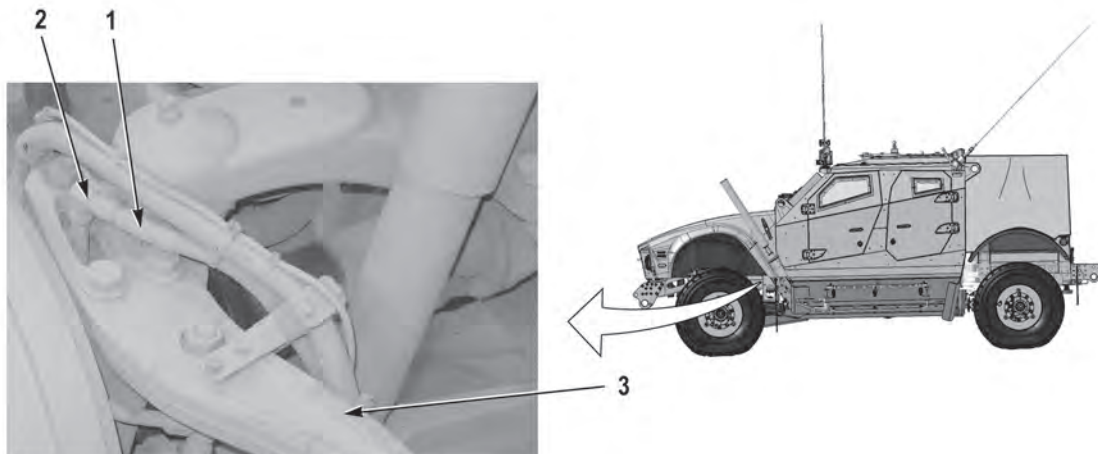
**REMOVAL****NOTE**

- All steering arms are removed the same way. Axle No. 1 driver side shown.
- Cap and plug hose upon removal.
- Remove cable ties as required.

1. Remove hose (1) from fitting (2).
2. Turn fitting (2) until fitting (2) is aligned with slot in steering arm (3).

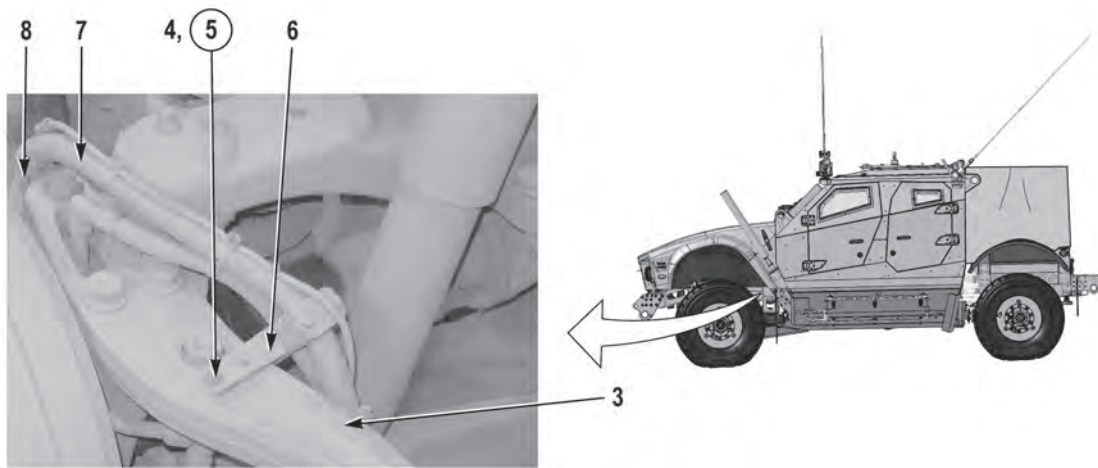

3. Remove two screws (4), lockwashers (5), and bracket (6) from steering arm (3). Discard lockwashers (5).
4. Remove hose (7) from fitting (8).

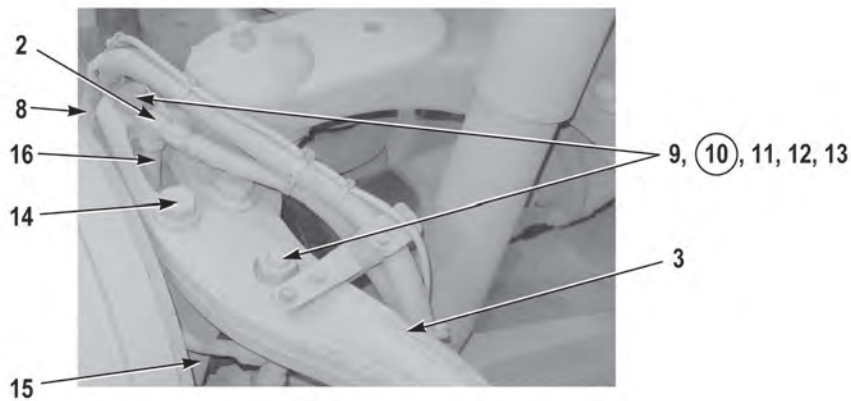

5. Remove two nuts (9), lockwashers (10), washers (11), and cone spacers (12) from two studs (13). Discard lockwashers (10).

### NOTE

A floor jack may be used to raise wheel end assembly.

6. Remove two screws (14) and steering arm (3) from knuckle (15).
7. Remove fittings (2, 8, and 16) from knuckle (15).

**END OF TASK**

---

**INSTALLATION****WARNING**

**Adhesives, solvents, and sealing compounds can burn easily, can give off harmful vapors, and are harmful to skin and clothing. To avoid injury or death, keep away from open fire and use in well-ventilated area. If adhesive, solvent, or sealing compound gets on skin or clothing, wash immediately with soap and water. Failure to comply may result in injury or death to personnel.**

**NOTE**

All steering arms are installed the same way. Axle No. 1 driver side shown.

1. Apply sealing compound, Loctite 242, to threads of fittings (2, 8, and 16).
2. Install fittings (2, 8, and 16) on knuckle (15).
3. Apply sealing compound, Loctite 242, to threads of two studs (13) and screws (14).
4. Install steering arm (3) on knuckle (15) and two studs (13) with two screws (14).
5. Install two cone spacers (12), washers (11), new lockwashers (10), and nuts (9) on studs (13). Tighten nuts (9) to 320 lb-ft (434 N•m).

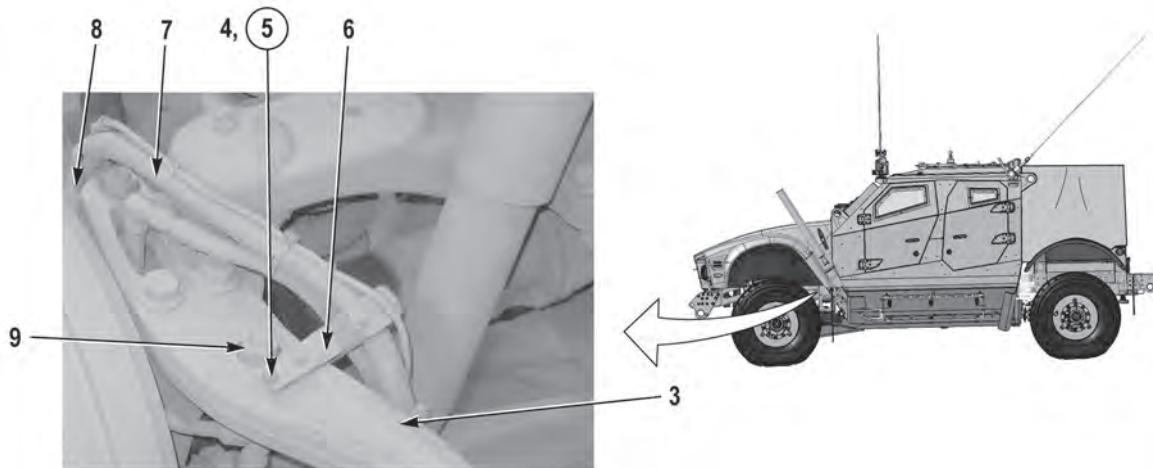

6. Install hose (7) on fitting (8).
7. Apply sealing compound, Loctite 242, to threads of two screws (4).
8. Install bracket (6) on steering arm (3) with two new lockwashers (5) and screws (4).

#### **NOTE**

Install cable ties as required.

9. Install hose (1) on fitting (2).
10. Apply sealing compound, Torque (F-1000), to two nuts (9).
11. Perform all Follow-On Maintenance tasks.

**END OF TASK**

**END OF WORK PACKAGE**

---

**STEERING COLUMN AND BRACKET REPLACEMENT**

---

**Preconditions**

Park vehicle  
 Engine OFF  
 Wheels chocked  
 CTIS dash panel removed (WP 0168)  
 Transmission dash panel removed (WP 0150)  
 Steering wheel removed (WP 0286)

**Tools and Special Tools**

Tool Kit, General Mechanic's: Automotive

**Materials/Parts**

Lockwasher (3) (Item 10)  
 Locknut (4) (Item 13)  
 Locknut (Item 17)  
 Locknut (3) (Item 21)

**Materials/Parts (Continued)**

Locknut (2) (Item 24)  
 Locknut (Item 28)  
 Locknut (Item 33)  
 Locknut (Item 35)  
 Lockwasher (3) (Item 39)  
 Lockwasher (3) (Item 42)  
 Compound, Sealing, Loctite 242  
 Tags, Identification  
 Ties, Cable

**Follow-On Maintenance**

Install transmission dash panel (WP 0150)  
 Install CTIS dash panel (WP 0168)  
 Install steering wheel (WP 0286)  
 Remove and stow wheel chocks

---

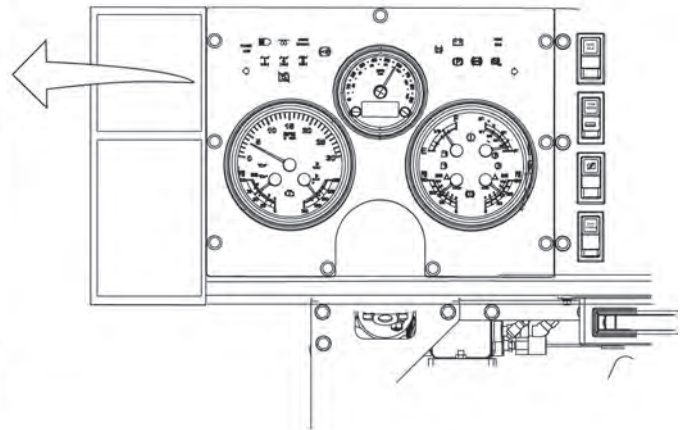
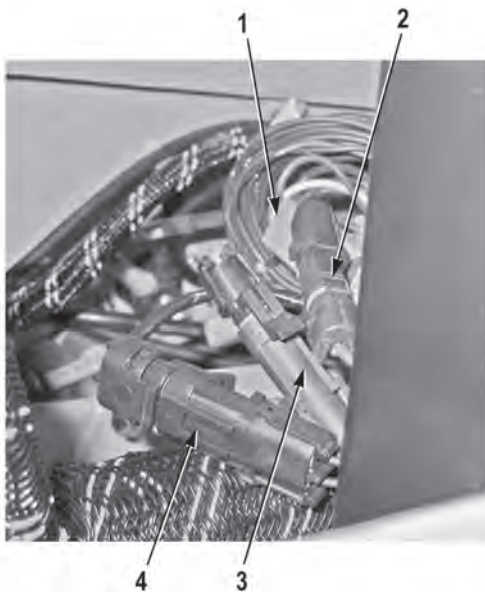
**REMOVAL****NOTE**

- Tag and mark connectors prior to removal to ensure proper installation.
- Remove cable ties as required.

1. Disconnect connector (1).
2. Disconnect connector (2).
3. Disconnect connector (3).
4. Disconnect connector (4).

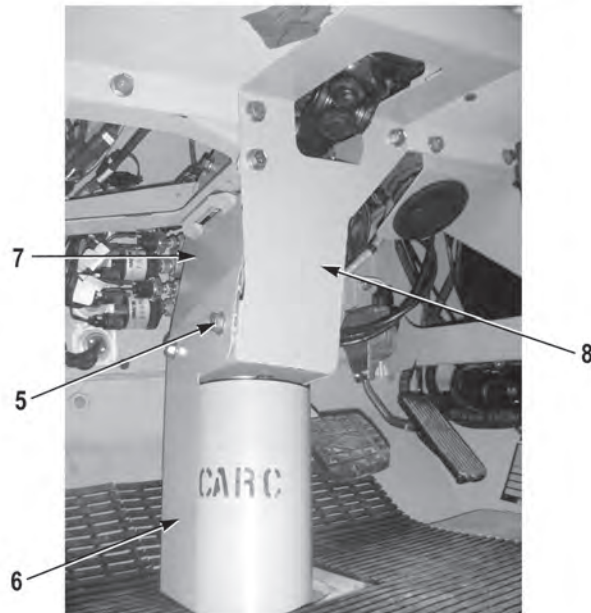

5. Remove four screws (5) and cover (6) from bracket (7) and steering column support (8).

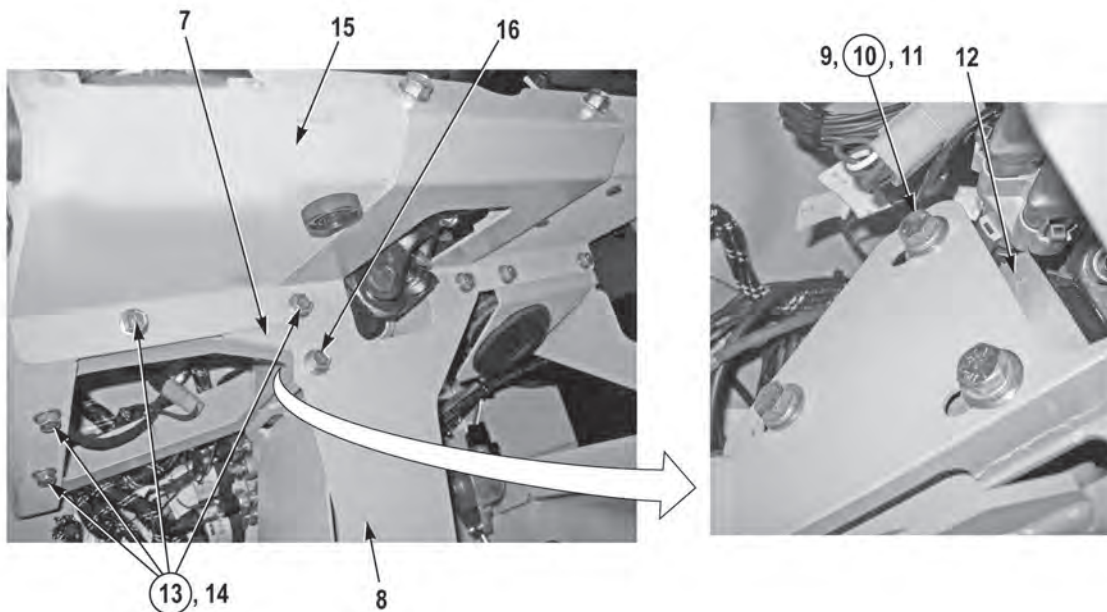

6. Remove three screws (9), lockwashers (10), and washers (11) from bracket (7) and steering gear miter box (12). Discard lockwashers (10).
7. Remove four locknuts (13), screws (14), and bracket (7) from steering column support (8) and dash assembly (15). Discard locknuts (13).
8. Remove screw (16) from steering column support (8).





9. Remove locknut (17) and screw (18) from yoke (19) and upper steering shaft (20). Discard locknut (17).

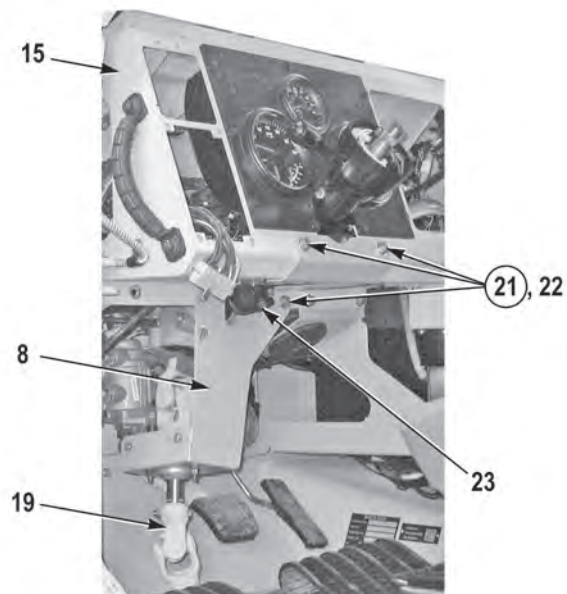

10. Remove three locknuts (21), screws (22), steering column assembly (23), and steering column support (8) from dash assembly (15) and yoke (19). Discard locknuts (21).

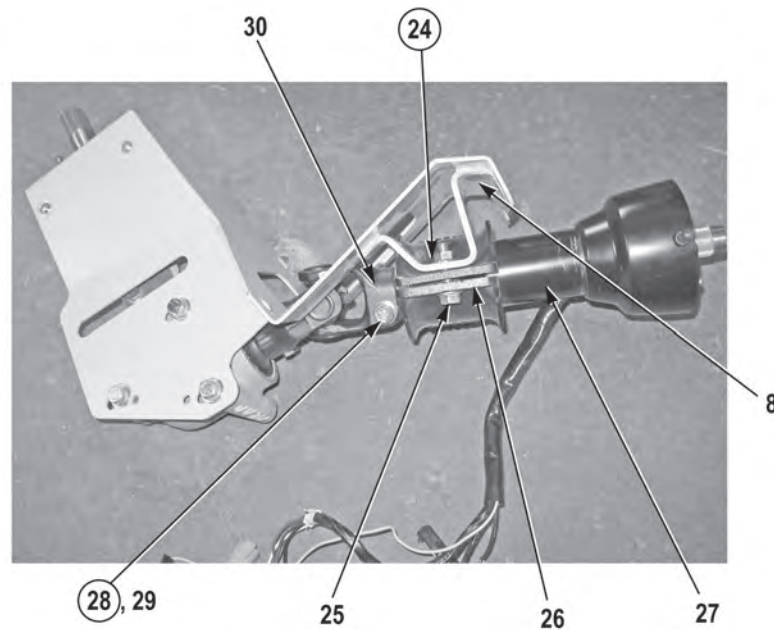

11. Remove two locknuts (24) screws (25), and two collars (26), from steering column support (8) and upper steering shaft (27). Discard locknuts (24).

#### NOTE

- Note position of steering shaft prior to removal to ensure proper installation.
- Spring retainer and spring may fall off steering column during removal.

12. Remove locknut (28), screw (29), and upper steering shaft (27) from yoke (30). Discard locknut (28).

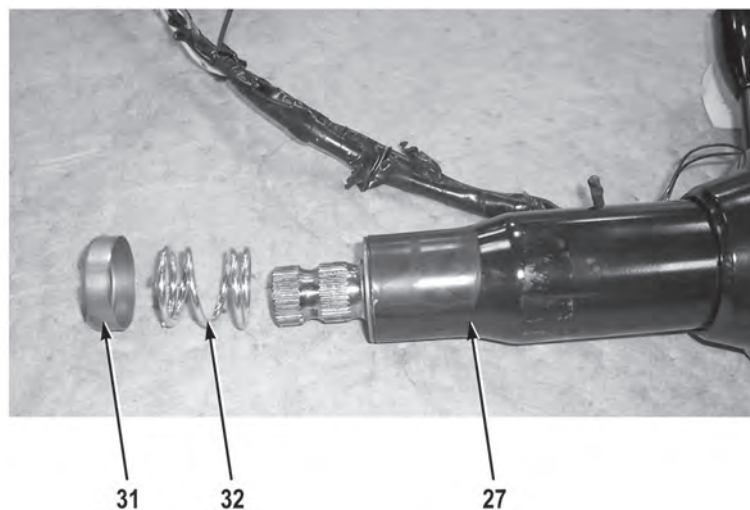

#### NOTE

Note position of spring retainer and spring support prior to removal to ensure proper installation.

13. Remove spring retainer (31) and spring (32) from upper steering shaft (27).

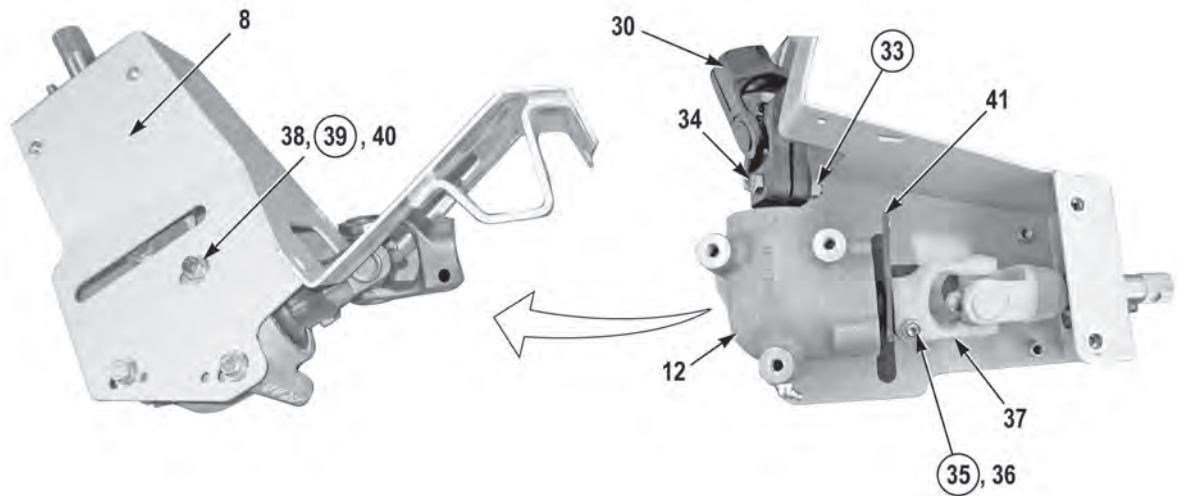

14. Remove locknut (33), screw (34), and yoke (30) from steering gear miter box (12). Discard locknut (33).
15. Remove locknut (35) and screw (36) from yoke (37). Discard locknut (35).

### NOTE

Note position of steering miter box prior to removal to ensure proper installation.

16. Remove three screws (38), lockwashers (39), washers (40), steering gear miter box (12) and bracket (41) from steering column support (8) and yoke (37). Discard lockwashers (39).

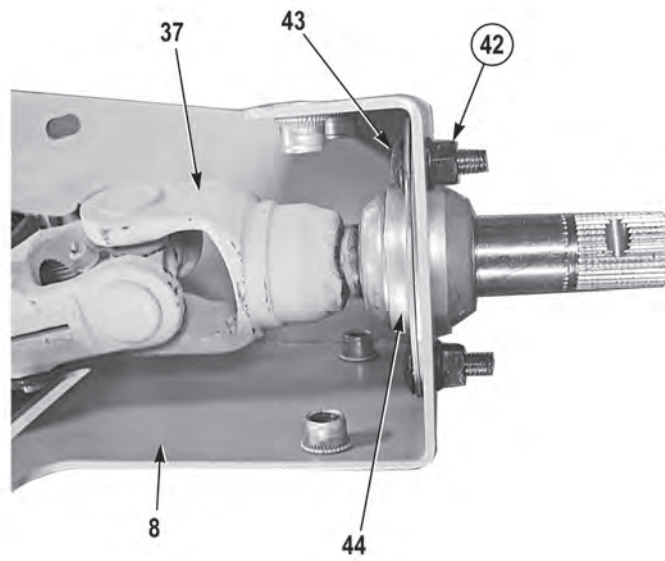

17. Remove three locknuts (42), screws (43), bearing (44), and yoke (37) from bracket (8). Discard locknuts (42).

#### END OF TASK

#### INSTALLATION

1. Install yoke (37) and bearing (44) on bracket (8) with three screws (43) and new locknuts (42).

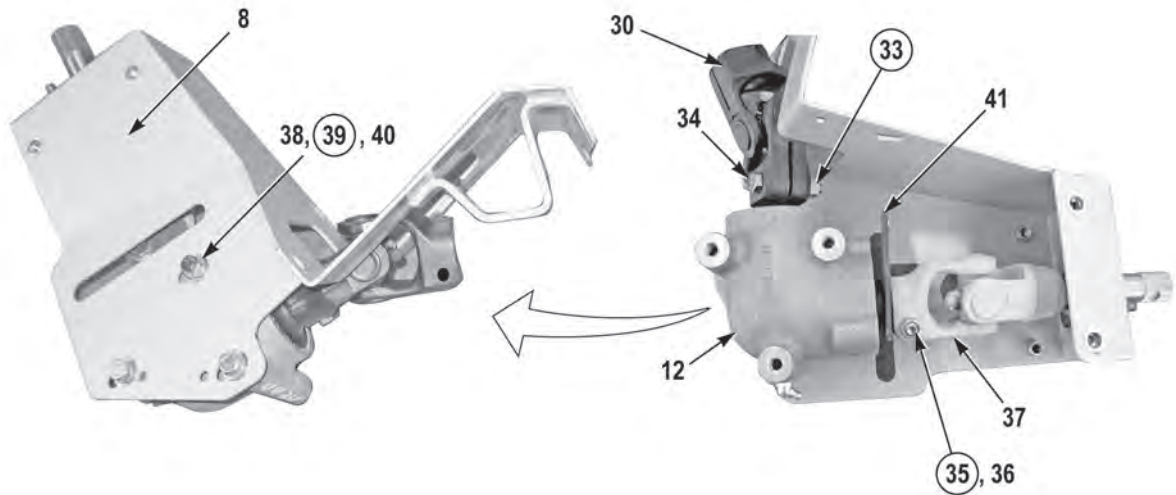

2. Position bracket (41) on steering gear miter box (12).

### NOTE

Install steering gear miter box as noted prior to removal.

3. Install steering gear miter box (12) and bracket (41) on steering column support (8) and yoke (37) with washers (40), new lockwashers (39), and screws (38).
4. Secure yoke (37) on steering gear miter box (12) and bracket (41) with screw (36) and new locknut (35).
5. Install yoke (30) on steering gear miter box (12) with screw (34) and new locknut (33).

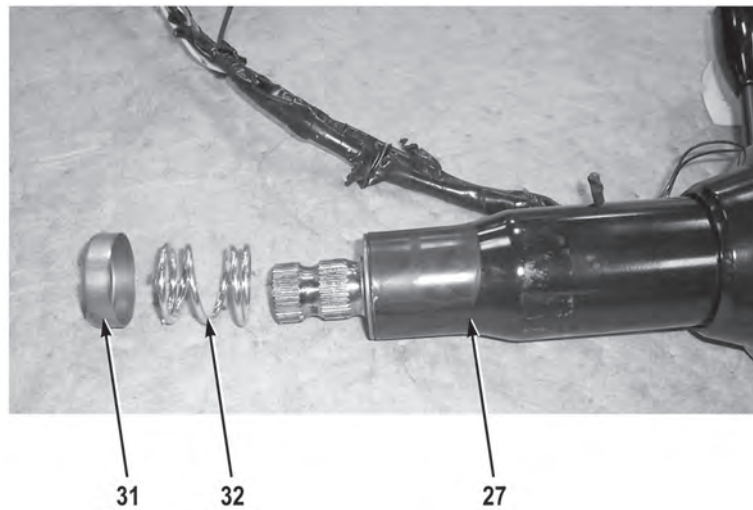
**NOTE**

Install spring and retaining spring as noted prior to removal.

6. Install spring retainer (31) and spring (32) on upper steering shaft (27).

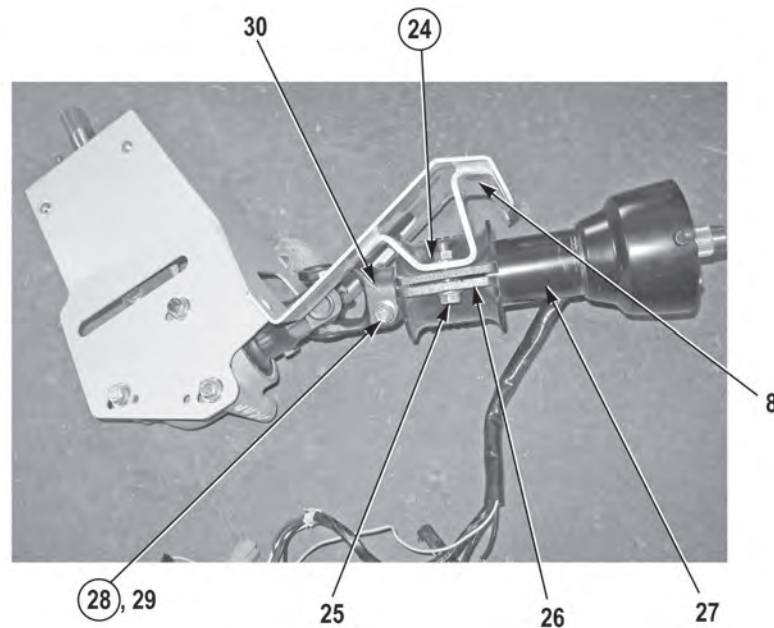
**NOTE**

Install steering shaft as noted prior to removal.

7. Install upper steering shaft (27) on yoke (30) with screw (29) and new locknut (28).
8. Secure steering column support (8) and two collars (26) on upper steering shaft (27) with two screws (25) and new locknuts (24).



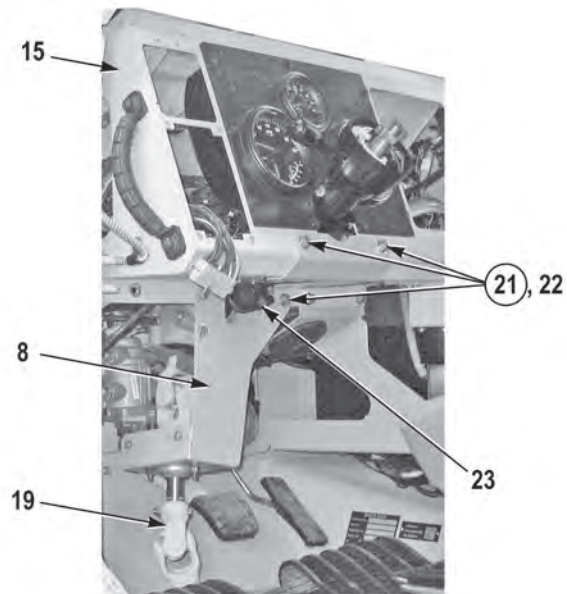

9. Install steering column assembly (23) and steering column support (8) on yoke (19) and dash assembly (15) with three screws (22) and new locknuts (21).



10. Secure upper steering shaft (20) to yoke (19) with screw (18) and new locknut (17).

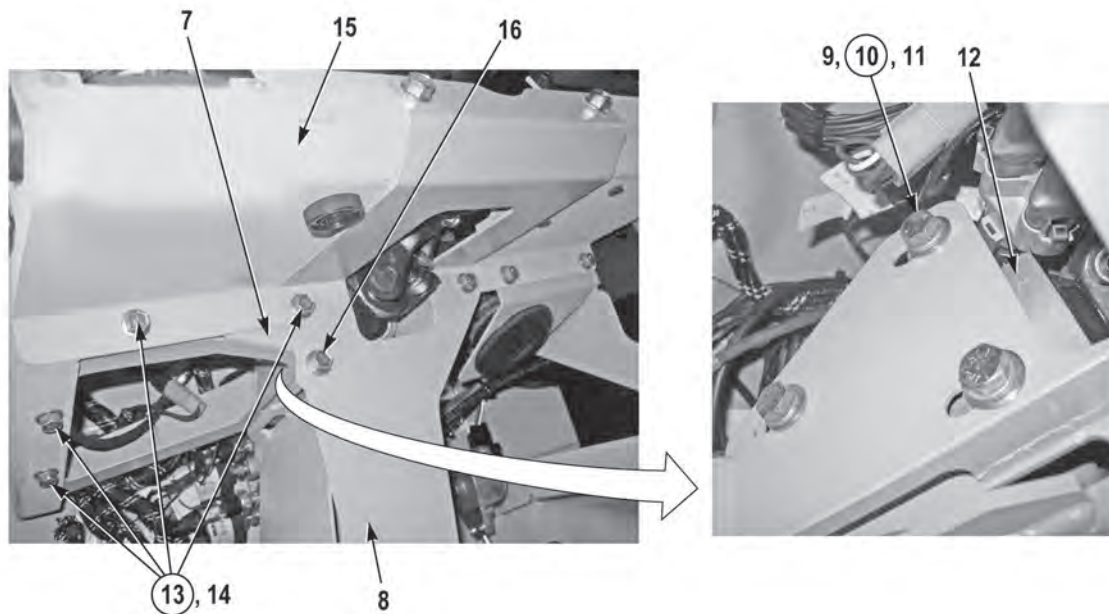

### **WARNING**

**Adhesives, solvents, and sealing compounds can burn easily, can give off harmful vapors, and are harmful to skin and clothing. To avoid injury or death, keep away from open fire and use in well-ventilated area. If adhesive, solvent, or sealing compound gets on skin or clothing, wash immediately with soap and water. Failure to comply may result in injury or death to personnel.**

11. Apply sealing compound, Loctite 242, to threads of screw (16).
12. Install screw (16) on steering column support (8).
13. Install bracket (7) on dash assembly (15) and steering column support (8) with four screws (14) and new locknuts (13).
14. Secure steering gear miter box (12) on bracket (7) with three new washers (11), new lockwashers (10), and screws (9).

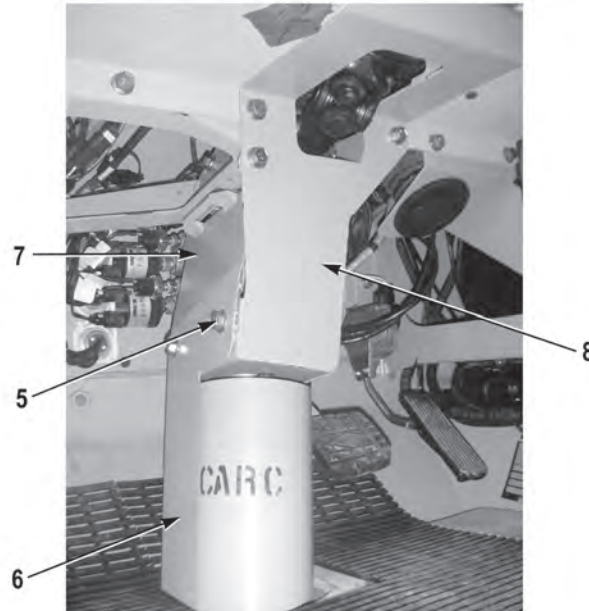

### **WARNING**

**Adhesives, solvents, and sealing compounds can burn easily, can give off harmful vapors, and are harmful to skin and clothing. To avoid injury or death, keep away from open fire and use in well-ventilated area. If adhesive, solvent, or sealing compound gets on skin or clothing, wash immediately with soap and water. Failure to comply may result in injury or death to personnel.**

15. Apply sealing compound, Loctite 242, to threads of four screws (5).
16. Install steering column cover (6) on steering column support (8) and bracket (7) with four screws (5).

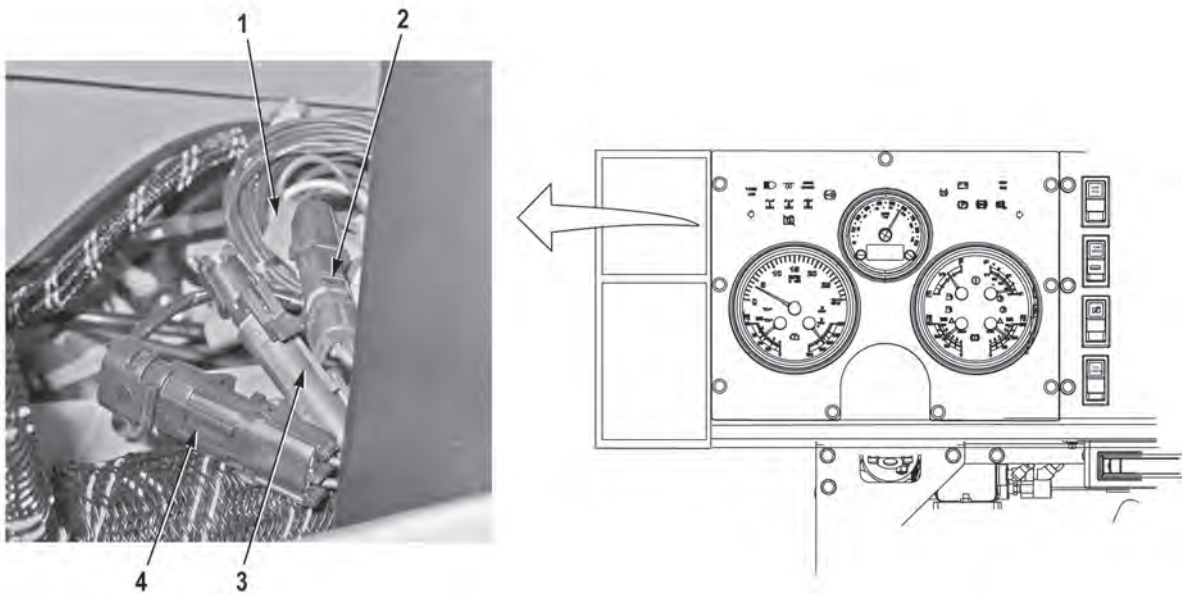

17. Connect connector (4).

#### **NOTE**

Install cable ties as required.

18. Connect connector (3).

19. Connect connector (2).

20. Connect connector (1).

21. Perform all Follow-On Maintenance tasks.

**END OF TASK**

**END OF WORK PACKAGE**

---

**STEERING GEAR MITRE REPLACEMENT**

---

**Preconditions**

Park vehicle  
 Engine OFF  
 Wheels chocked  
 Front driver side wheel well deflector panel removed (M1240/M1245) (WP 0059)  
 Front wheel well deflector panel removed (M1240A1) (WP 0057)

**Tools and Special Tools**

Tool Kit, General Mechanic's: Automotive  
 Wrench, Torque, 75 ft-lb

**Materials/Parts**

Locknut (Item 1)  
 Locknut (3) (Item 5)  
 Compound, Corrosion Preventive, Ultra Tef-Gel 05SA2

**Follow-On Maintenance**

Install front driver side wheel well deflector panel (M1240/M1245) (WP 0059)  
 Install front wheel well deflector panel (M1240A1) (WP 0057)  
 Remove and stow wheel chocks

---

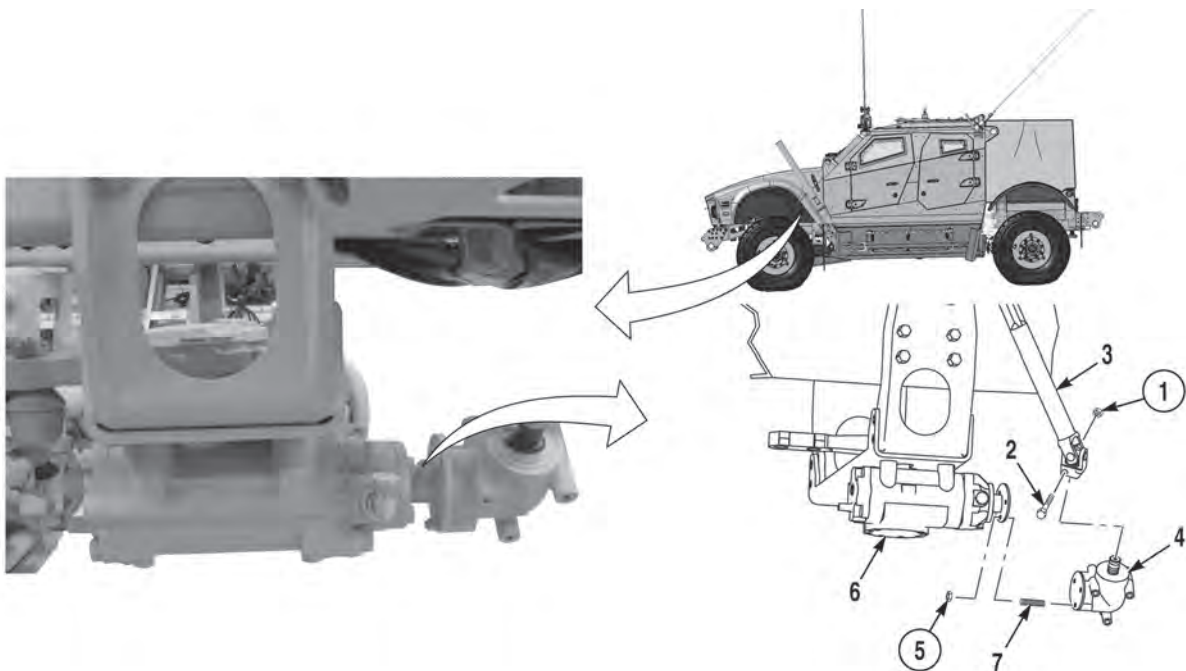
**REMOVAL****NOTE**

Position wheels straight ahead and note position of splines, steering wheel, and mitre gear prior to removal of lower steering shaft to ensure proper installation.

1. Remove locknut (1), screw (2), and lower steering shaft (3) from steering gear mitre (4). Discard locknut (1).

**NOTE**

Remove cushion clips as required.

2. Remove three locknuts (5) and steering gear mitre (4) from steering gear (6). Discard locknuts (5).

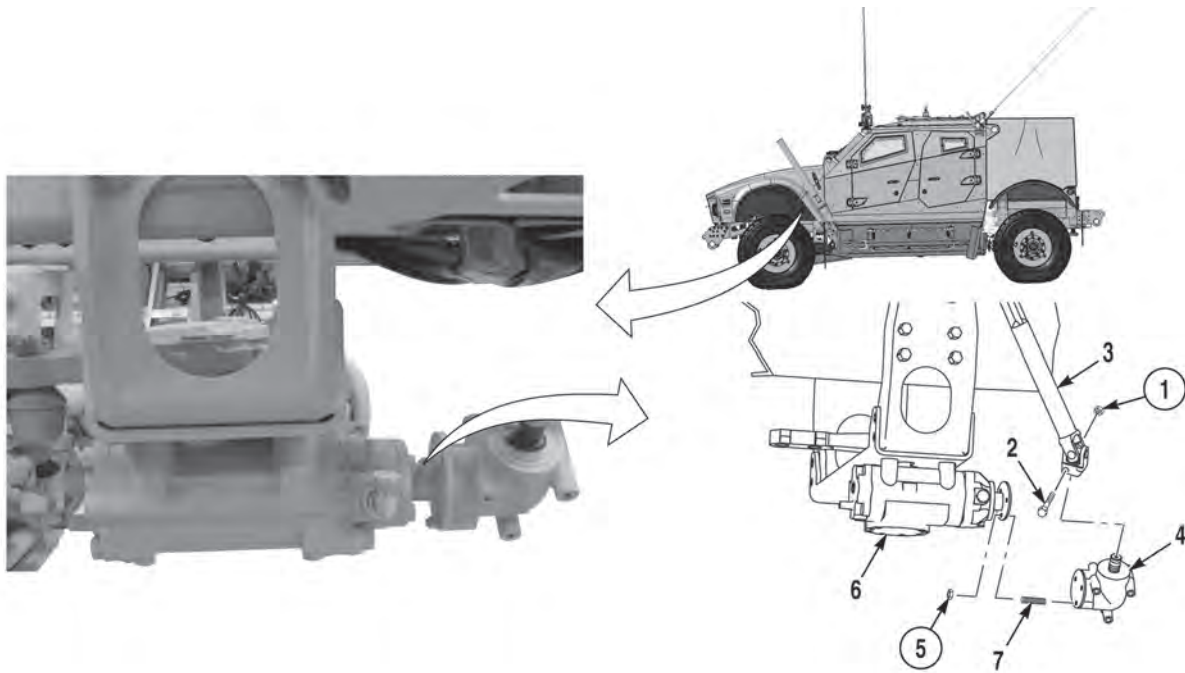
**NOTE**

Perform Step (3) if studs are damaged.

3. Remove three studs (7) from steering gear mitre (4).

**END OF TASK****INSTALLATION****NOTE**

Perform Step (1) if studs were removed.

1. Install three studs (7) on steering gear mitre (4).

**NOTE**

Install cushion clips as required.

2. Install steering gear mitre (4) on steering gear (6) with three new locknuts (5).



---

**WARNING**

Anti-corrosion compound is toxic. Use only in well-ventilated area. Use NIOSH/MSHA-approved respirator with dual organic vapor/mist and particulate cartridge. Do not get in eyes; wear chemical safety goggles and full face shield when using. Avoid contact with skin and wear rubber or plastic, solvent-resistant gloves. In case of contact, remove contaminated clothing and immediately wash area with soap and water. If eyes are contacted, flush eyes with large amounts of water for at least 15 minutes and get immediate medical attention. If swallowed, do not induce vomiting; contact a physician immediately. Failure to comply may result in injury or death to personnel.

3. Apply corrosion preventive compound, Ultra Tef-Gel 05SA2, to splines of shaft on steering gear mitre (4).

**NOTE**

Ensure steering wheel is in proper position as noted prior to removal.

4. Install lower steering shaft (3) on steering gear mitre (4) with screw (2) and new locknut (1). Tighten locknut to 40 lb-ft (54 N•m).
5. Perform all Follow-On Maintenance tasks.

**END OF TASK**

**END OF WORK PACKAGE**



---

**STEERING GEAR RELIEF ADJUSTMENT**

---

**Preconditions**

Park vehicle  
Engine OFF  
Wheels chocked

**Personnel Required**

Two

**Follow-On Maintenance**

Remove and stow wheel chocks

**Tools and Special Tools**

Tool Kit, General Mechanic's: Automotive

**Materials/Parts**

Grease, Automotive and Artillery  
Screwdriver, Jeweler, 2.5 mm

---

**ADJUSTMENT****WARNING**

**While engine is running, transmission MUST be in N (neutral), PARKING BRAKE must be set and properly engaged, and wheels MUST be chocked. Failure to comply may result in injury or death to personnel.**

**NOTE**

When performing this task, vehicle should be on dry shop floor surface or dry pavement.

1. Start engine.

**WARNING**

**Stand clear of vehicle while wheels are turned. Failure to comply may result in injury or death to personnel.**

**CAUTION**

**Do not hold steering wheel at full left or full right for longer than 10 seconds. Oil overheating may occur. Failure to comply may result in damage to equipment.**

2. Turn wheels to left until wheels stop.

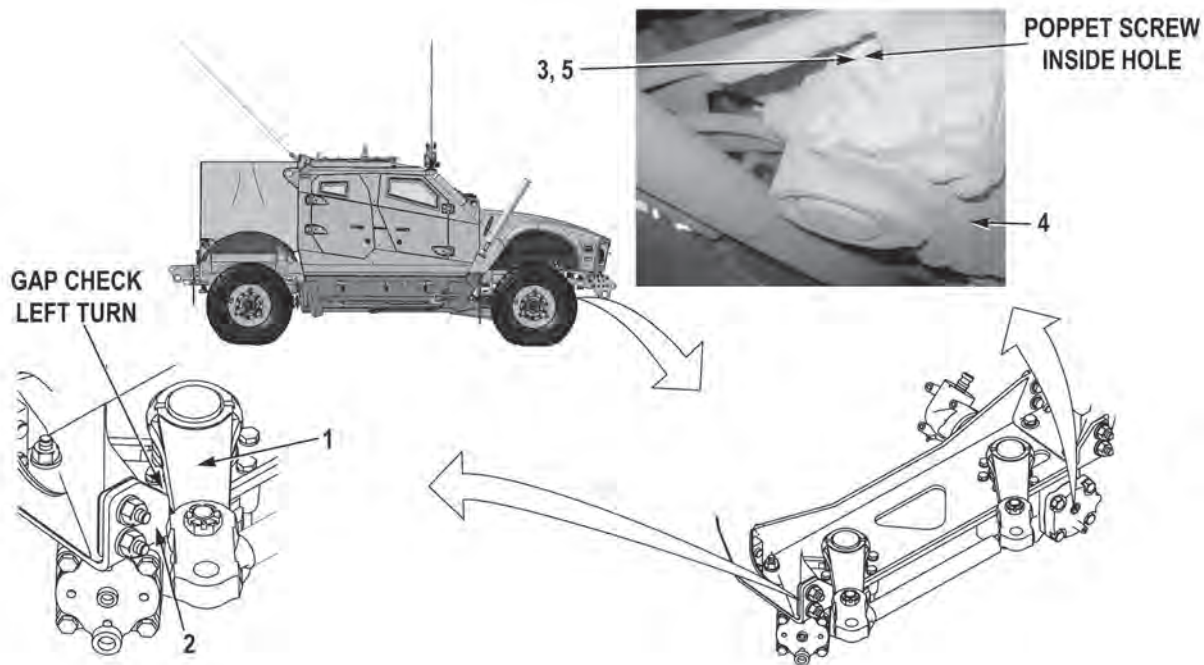

### NOTE

- While performing Step (3), hold wheels in full left turn position.
  - Gap dimension must be 0.150 in.  $\pm$  0.030 in. (3.810 mm  $\pm$  0.762 mm).
3. With the aid of an assistant, using a feeler gage, measure gap between passenger side pitman arm (1) and steering gear tray (2).

### WARNING

**Do not adjust front poppet screw beyond flush with steering gear cover. Failure to comply may result in damage to equipment or injury to personnel.**

### NOTE

- Perform Step (4) if gap is not within correct dimensions.
  - Turning poppet screw in will increase gap between passenger side pitman arm and steering gear tray.
  - Turning poppet screw out will decrease gap between passenger side pitman arm and steering gear tray.
  - A jewelers flathead screwdriver is needed to turn poppet screw.
4. Turn front poppet screw (3) on primary steering gear (4) to adjust gap between passenger side pitman arm (1) and steering gear tray (2).
5. Repeat Steps (3) and (4) until gap is within correct dimensions.
6. Pack front poppet screw hole (5) with grease.

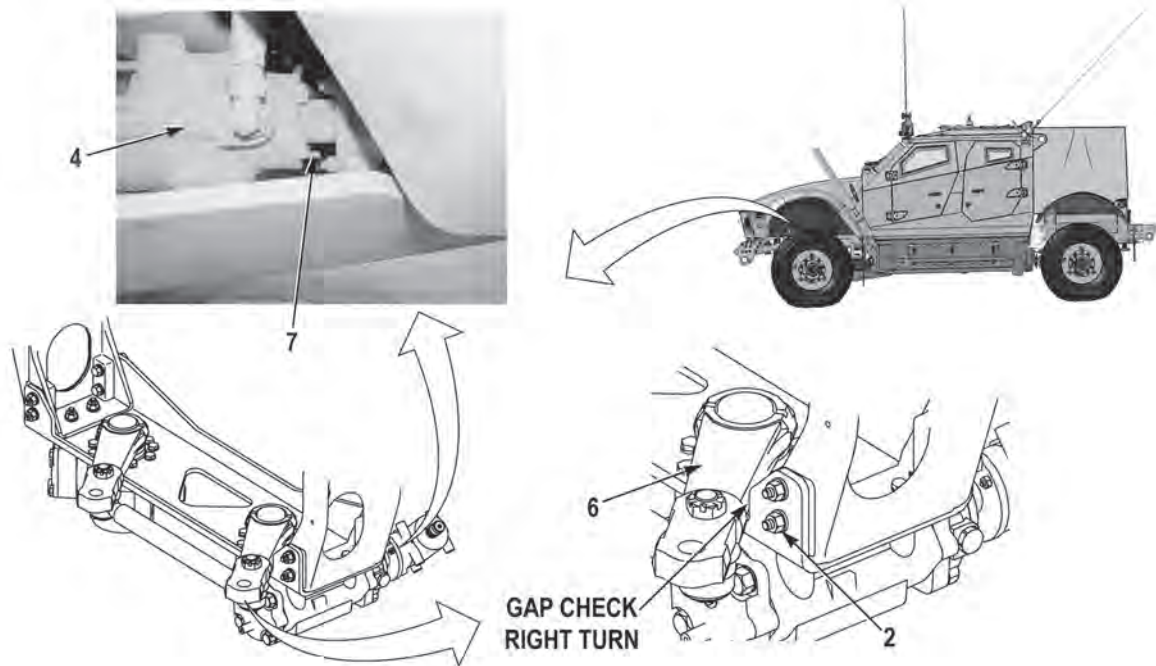

### **WARNING**

Stand clear of vehicle while wheels are turned. Failure to comply may result in injury or death to personnel.

### **CAUTION**

Do not hold steering wheel at full left or full right for longer than 10 seconds. Oil overheating may occur. Failure to comply may result in damage to equipment.

7. Turn wheels to right until wheels stop.

### **NOTE**

- While performing Step (8), hold wheels in full right turn position.
- Gap dimension must be 0.150 in.  $\pm$  0.030 in. (3.810 mm  $\pm$  0.762 mm).

8. With the aid of an assistant, using a feeler gage, measure gap between driver side pitman arm (6) and steering gear tray (2).

### **NOTE**

- Perform Step (9) if gap is not within correct dimensions.
- Turning poppet screw in will increase gap between driver side pitman arm and steering gear tray.
- Turning poppet screw out will decrease gap between driver side pitman arm and steering gear tray.
- Needle nose pliers is needed to turn poppet screw.

9. Turn rear poppet screw (7) on primary steering gear (4) to adjust gap between driver side pitman arm (6) and steering gear tray (2).
10. Repeat Steps (8) and (9) until gap is within correct dimensions.
11. Shut off engine.
12. Perform all Follow-On Maintenance tasks.

**END OF TASK**

**END OF WORK PACKAGE**



---

**STEERING GEAR TRAY REPLACEMENT**

---

**Preconditions**

Park vehicle  
Engine OFF  
Wheels chocked  
Engine belly deflector panel removed (WP 0050)  
Propeller shaft removed (WP 0090)  
Lower steering shaft removed (WP 0272)  
Steering gear mitre removed (WP 0283)  
Tow control links removed (WP 0288)  
Tie rod removed (WP 0287)

**Tools and Special Tools**

Pan, Drain  
Jack, Transmission  
Tool Kit, General Mechanic's: Automotive

**Materials/Parts**

O-ring (Item 3)  
O-ring (Item 7)  
Locknut (10) (Items 9 and 13)  
Lockwasher (2) (Item 16)  
Cap and Plug Set  
Oil, Hydraulic  
Tags, Identification  
Ties, Cable

**Personnel Required**

Two

**Follow-On Maintenance**

Install tie rod (WP 0287)  
Install tow control links (WP 0288)  
Install steering gear mitre (WP 0283)  
Install lower steering shaft (WP 0272)  
Install propeller shaft (WP 0090)  
Install engine belly deflector panel (WP 0050)  
Fill power steering reservoir (WP 0278)  
Remove and stow wheel chocks

## REMOVAL

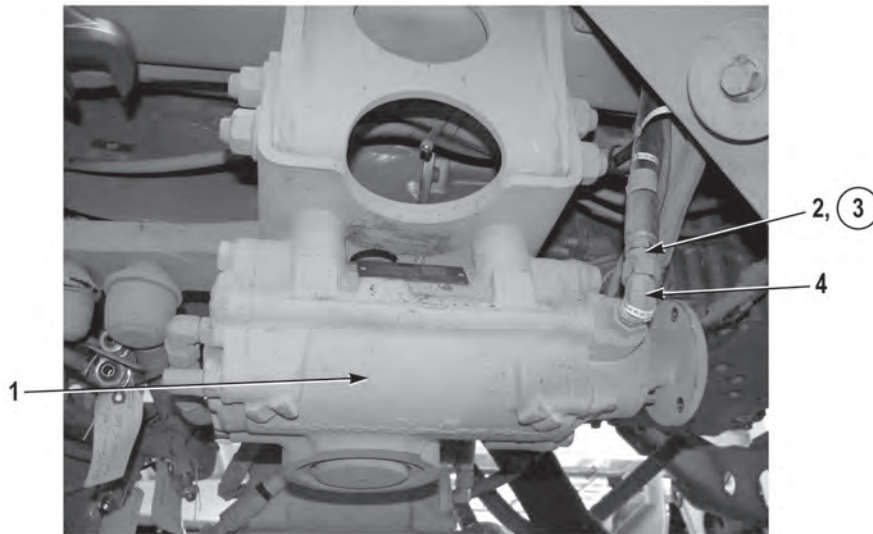

## NOTE

- Remove cable ties as required.
- Tag and mark hoses prior to removal to ensure proper installation.
- Cap and plug hoses and fittings upon removal.

1. Position suitable drain pan under primary steering gear (1) and hose (2).
2. Remove hose (2) and O-ring (3) from fitting (4). Discard O-ring (3).

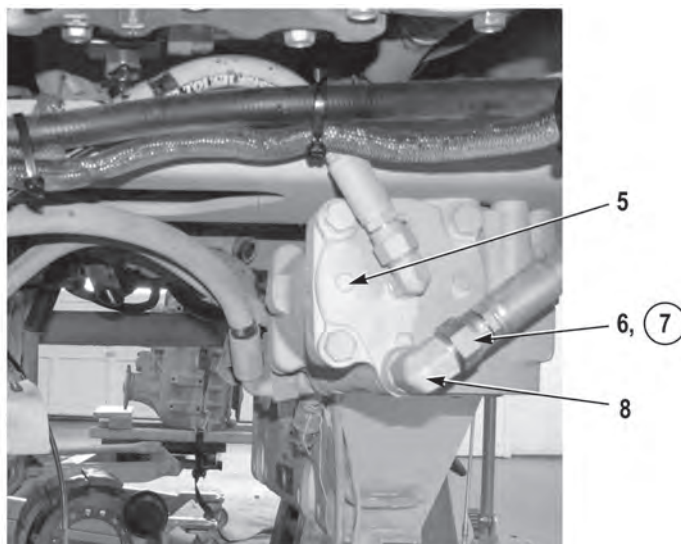

3. Position suitable drain pan under secondary steering gear (5) and hose (6).
4. Remove hose (6) and O-ring (7) from fitting (8). Discard O-ring (7).

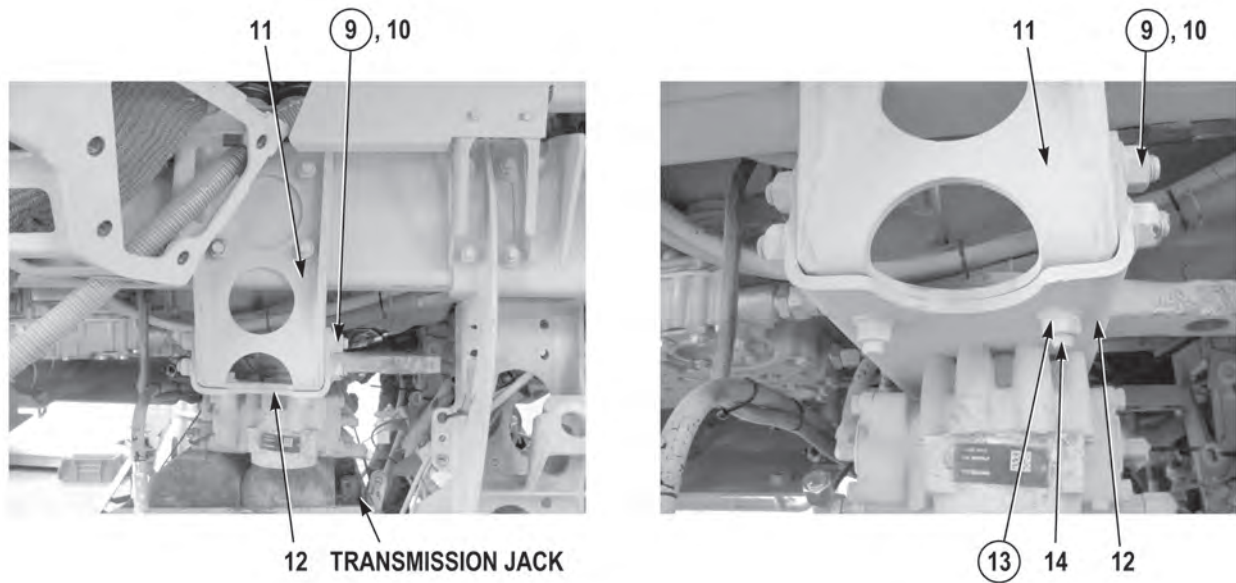

### NOTE

Driver side and passenger side steering gear tray are removed the same way. Passenger side shown.

- Remove four locknuts (9) and screws (10) from bracket (11) and steering gear tray (12). Discard locknuts (9).

### WARNING

**Combined weight of steering gear tray and steering gears is 319 lbs (145 kg). Do not lift or move steering gear tray and steering gears without the aid of an assistant and a lifting device. Failure to comply may result in injury or death to personnel.**

### NOTE

- Driver side steering gear tray does not have locknuts.
  - Perform Step (6) for passenger side.
  - Perform Step (7) for driver side.
- Remove two locknuts (13) and screws (14) from steering gear tray (12) and bracket (11). Discard locknuts (13).

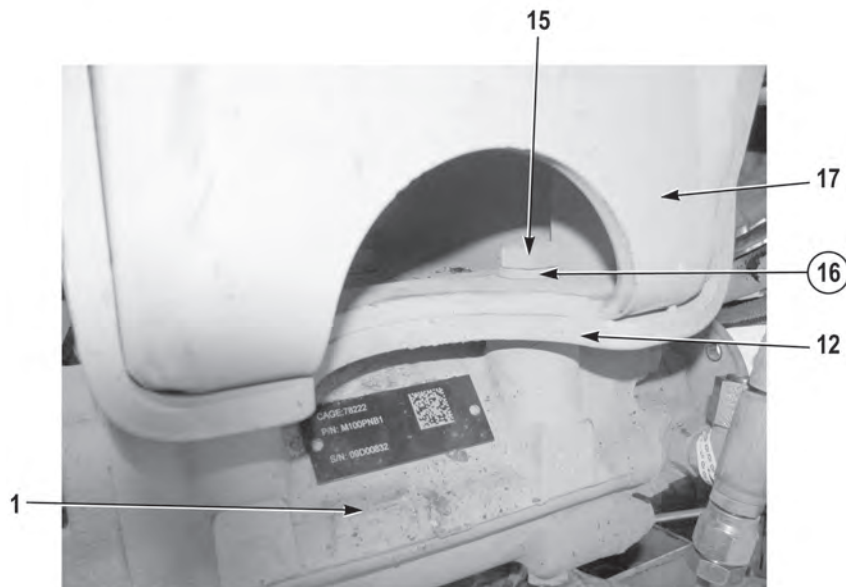

### NOTE

Note position of screws prior to removal to ensure proper installation.

7. Remove two screws (15) and lockwashers (16) from steering gear tray (12), bracket (17), and primary steering gear (1). Discard lockwashers (16).

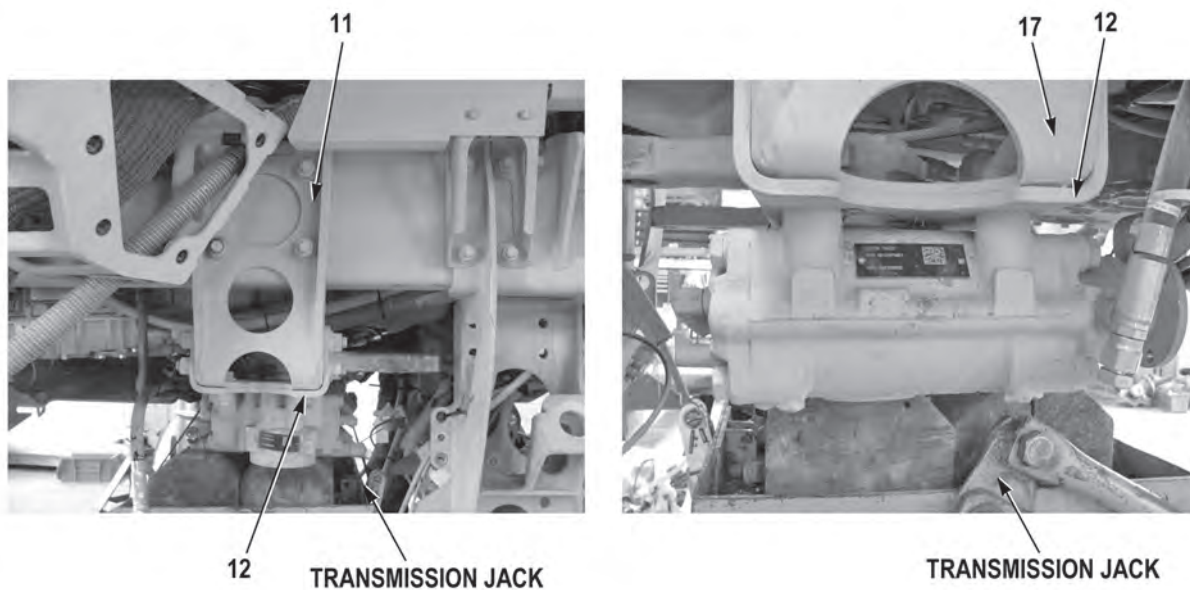

8. With the aid of an assistant and transmission jack, remove steering gear tray (12) from bracket (11) and bracket (17).

**END OF TASK**

**INSTALLATION****WARNING**

**Combined weight of steering gear tray and steering gears is 319 lbs (145 kg). Do not lift or move steering gear tray and steering gears without the aid of an assistant and a lifting device. Failure to comply may result in injury or death to personnel.**

1. With the aid of an assistant and transmission jack, position steering gear tray (12) on two brackets (11 and 17).

**NOTE**

- Driver side steering gear tray does not have locknuts.
  - Perform Step (2) for driver side.
  - Perform Step (3) for passenger side.
2. Install two new lockwashers (16) and screws (15) on steering gear tray (12), bracket (17), and primary steering gear (1).

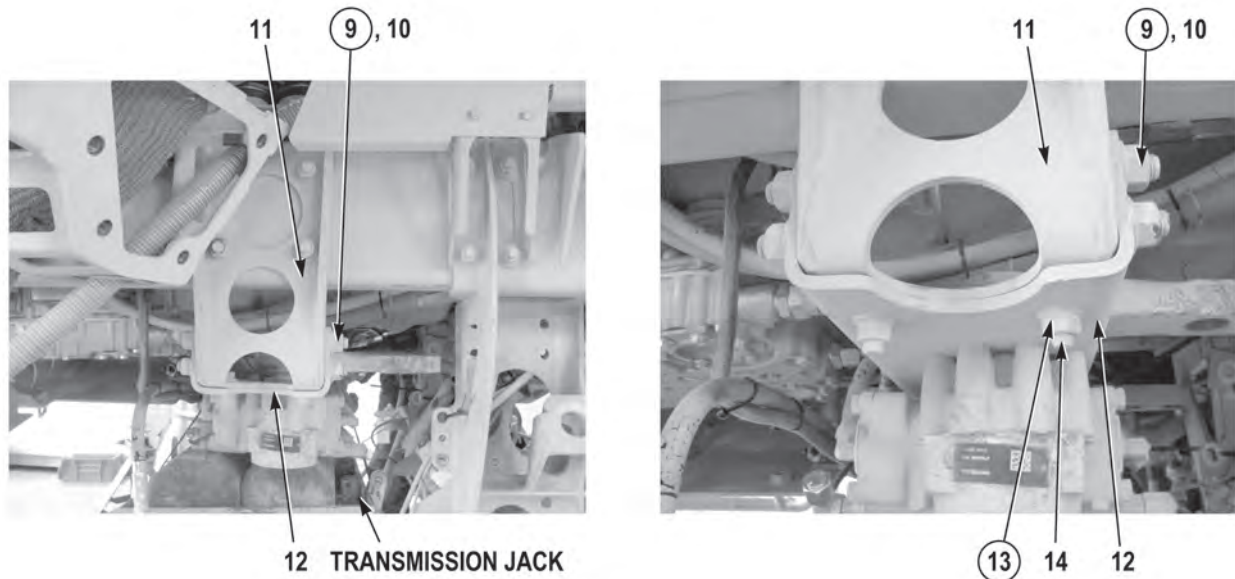

3. Install two screws (14) and new locknuts (13) on steering gear tray (12) and bracket (11).

**NOTE**

Driver side and passenger side steering gear tray are installed the same way. Passenger side shown.

4. Install four screws (10) and new locknuts (9) on steering gear tray (12) and bracket (11).

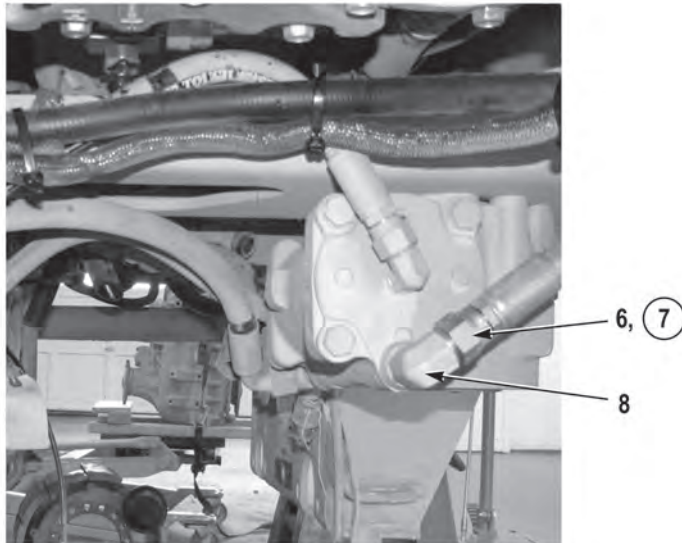

**NOTE**

Install cable ties as required.

5. Lightly lubricate new O-ring (7) with clean oil and install O-ring (7) and hose (6) on fitting (8).

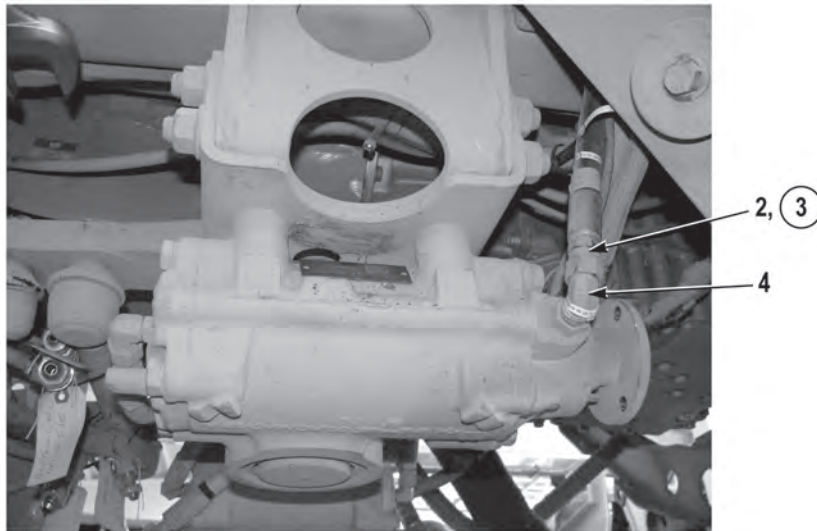

6. Lightly lubricate new O-ring (3) with clean oil and install O-ring (3) and hose (2) on fitting (4).
7. Perform all Follow-On Maintenance tasks.

**END OF TASK**

**END OF WORK PACKAGE**



---

**STEERING WHEEL REPLACEMENT**

---

**Preconditions**

Park vehicle  
Engine OFF  
Wheels chocked  
Batteries disconnected (M1240/M1240A1)  
(WP 0186)  
Batteries disconnected (M1245) (WP 0187)

**Materials/Parts**

Adhesive

**Follow-On Maintenance**

Connect batteries (M1240/M1240A1) (WP 0186)  
Connect batteries (M1245) (WP 0187)  
Remove and stow wheel chocks

**Tools and Special Tools**

Kit, Puller  
Socket, 1-1/4 in.  
Tool Kit, General Mechanic's: Automotive  
Wrench, Torque, 75 ft-lb

---

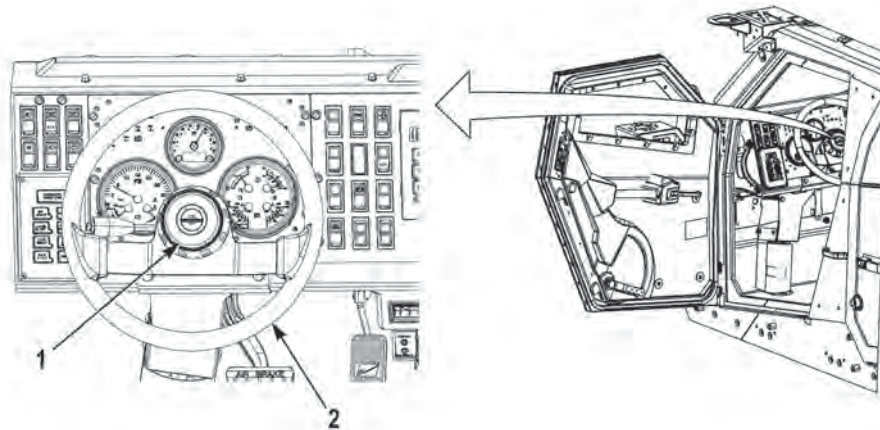
**REMOVAL**

1. Remove horn cap (1) from steering wheel (2).

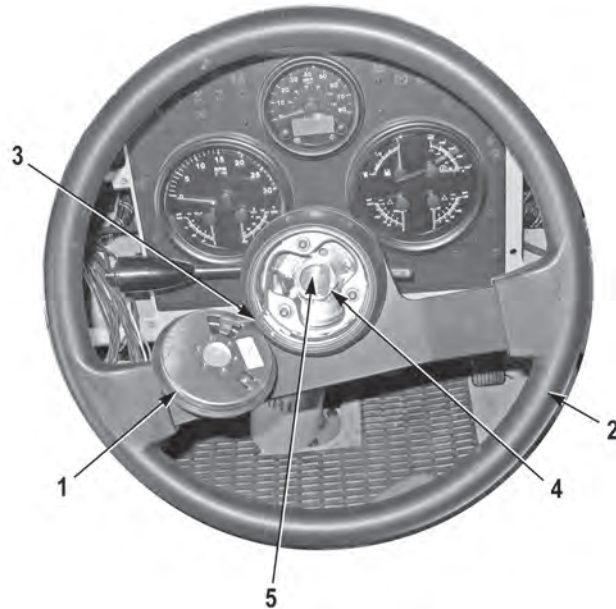

2. Disconnect wire (3) from horn cap (1).
3. Remove nut (4) from steering shaft (5).

### NOTE

Note position of steering wheel prior to removal to ensure proper installation.

4. Using a puller kit, remove steering wheel (2) from steering shaft (5).

### END OF TASK

### INSTALLATION

### NOTE

Install steering wheel as noted prior to removal.

1. Install steering wheel (2) on steering shaft (5).
2. Install nut (4) on steering shaft (5). Tighten nut to 65 lb-ft (88 N•m).
3. Connect wire (3) to horn cap (1).

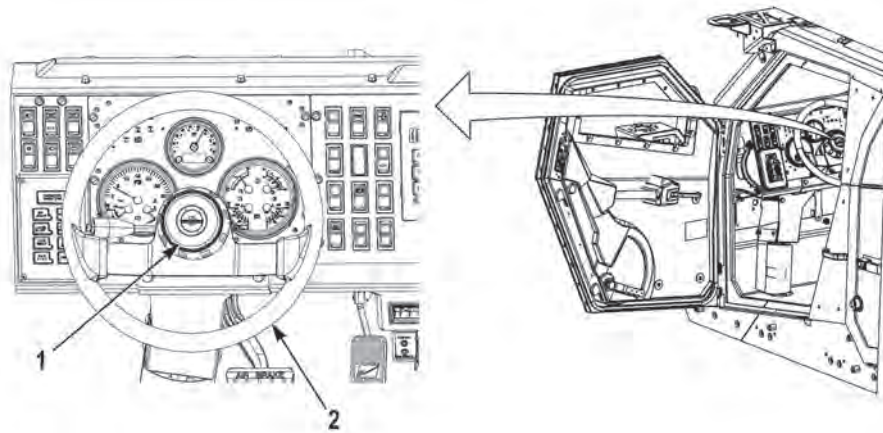
**NOTE**

If horn button cover separates from metal housing, put a thin bead of adhesive along mating surface. Let dry prior to reinstalling on steering wheel.

4. Install horn cap (1) on steering wheel (2).
5. Perform all Follow-On Maintenance tasks.

**END OF TASK****END OF WORK PACKAGE**



---

**TIE ROD REPLACEMENT**

---

**Preconditions**

Park vehicle  
 Engine OFF  
 Wheels chocked  
 Engine belly deflector panel removed  
 (M1240/M1245) (WP 0050)  
 Engine belly deflector panel removed (M1240A1)  
 (WP 0056)

**Tools and Special Tools**

Tool Kit, General Mechanic's: Automotive  
 Wrench, Combination 1-7/16 in.  
 Wrench, Torque, 250 ft-lb

**Personnel**

Two

**Materials/Parts**

Pin, Cotter (2) (Item 1)  
 Compound, Antiseize

**Follow-On Maintenance**

Install engine belly deflector panel  
 (M1240/M1245) (WP 0050)  
 Install engine belly deflector panel (M1240A1)  
 (WP 0056)  
 Remove and stow wheel chocks

---

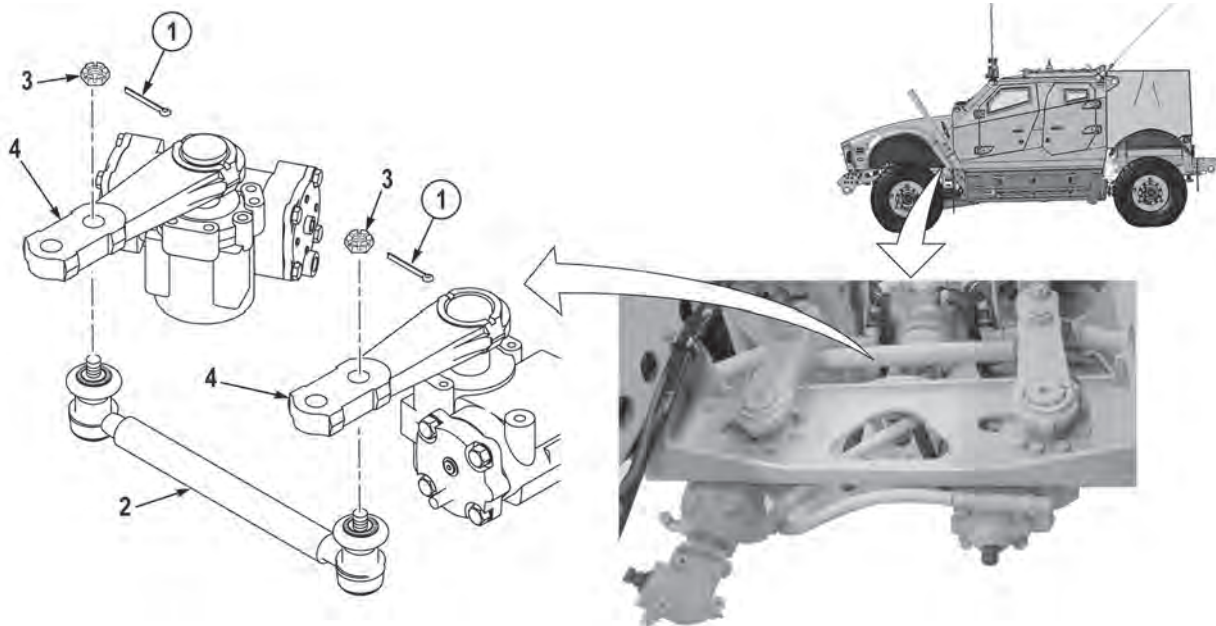
**REMOVAL**

1. Remove two cotter pins (1) from tie rod (2). Discard cotter pins (1).
2. Loosen two castle nuts (3) until flush with threads on tie rod (2).

**CAUTION**

**Do not use a removal tool to aid in removal of tie rod from pitman arm. Failure to comply may result in damage to dust cover.**

3. With the aid of an assistant and pry bar, apply pressure to top of castle nut (3) while hitting pitman arm (4) with hammer.
4. Remove castle nut (3) from tire rod (2).

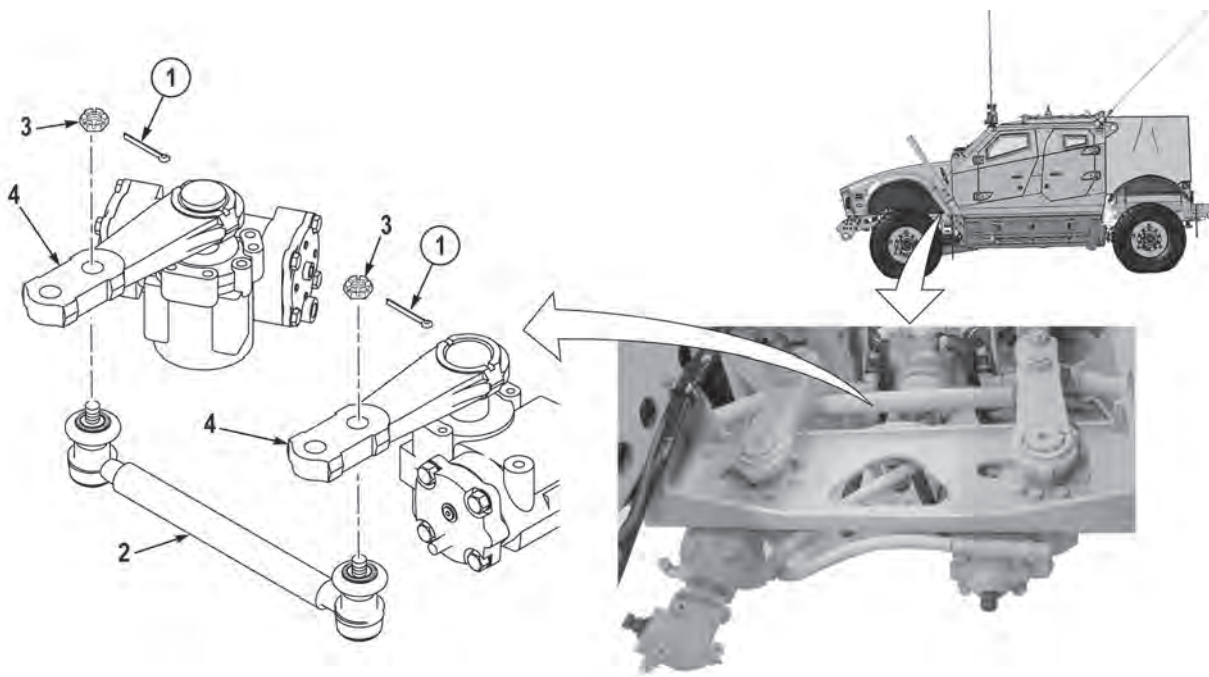

### NOTE

Note position of tie rod prior to removal to ensure proper installation.

5. Remove tie rod (2) from two pitman arms (4).

### END OF TASK

### INSTALLATION

#### WARNING

Adhesives, solvents, and sealing compounds can burn easily, can give off harmful vapors, and are harmful to skin and clothing. To avoid injury or death, keep away from open fire and use in well-ventilated area. If adhesive, solvent, or sealing compound gets on skin or clothing, wash immediately with soap and water. Failure to comply may result in injury or death to personnel.

1. Apply antiseize compound to threads of tie rod (2) ends.

### NOTE

Install tie rod as noted prior to removal.

2. Install tie rod (2) on two pitman arms (4) using castle nuts (3).



**WARNING**

**When tightening castle nut, do not loosen castle nut to install cotter pin. Continue to tighten castle nut until cotter pin can be installed. Failure to comply may result in injury or death to personnel.**

3. Tighten two castle nuts (3) to 145 lb-ft (197 N•m) and continue to tighten until two new cotter pins (1) can be installed.
4. Perform all Follow-On Maintenance tasks.

**END OF TASK**

**END OF WORK PACKAGE**



---

**TOE CONTROL LINK REPLACEMENT, AXLE NO. 1**

---

**Preconditions**

Park vehicle  
 Engine OFF  
 Wheels chocked

**Tools and Special Tools**

Tool Kit, General Mechanic's: Automotive  
 Wrench, Crowfoot Socket, 1-7/16 in.  
 Wrench, Torque, 250 ft-lb

**Materials/Parts**

Pin, Cotter (2) (Item 1)

**Personnel Required**

Two

**Follow-On Maintenance**

Adjust steering alignment (axle No. 1) (Notify Supervisor)  
 Remove and stow wheel chocks

---

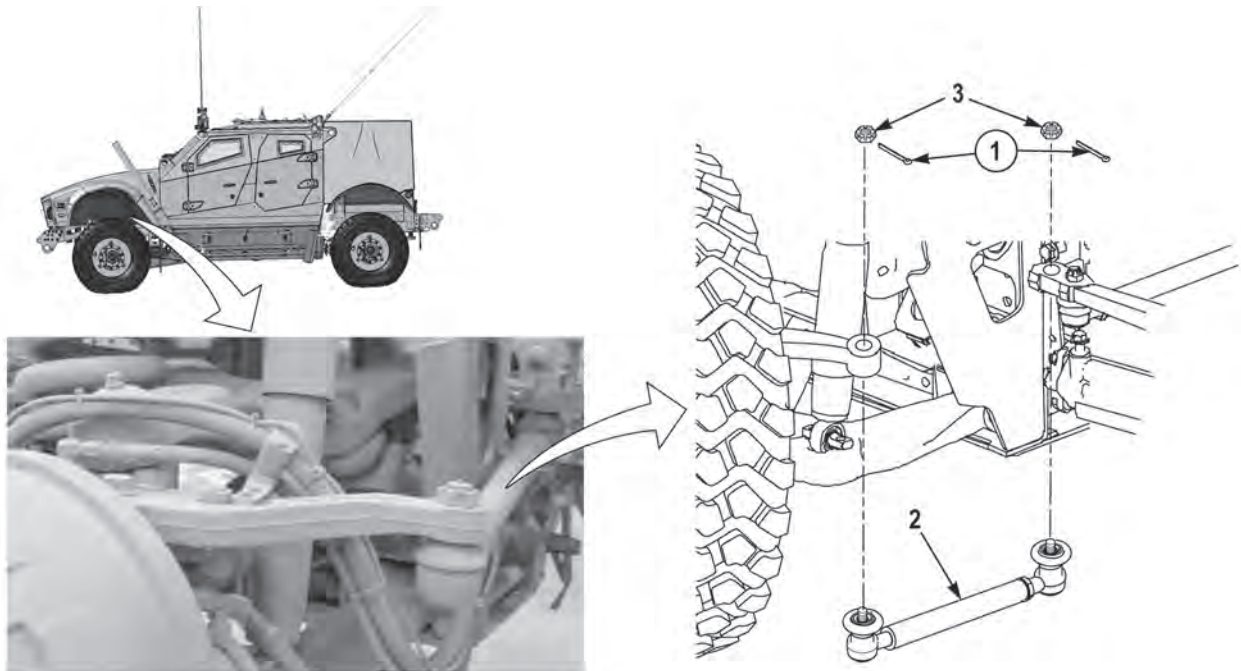
**REMOVAL****NOTE**

Both toe control links are removed the same way.

1. Remove cotter pin (1) from toe control link (2). Discard cotter pin (1).
2. Remove castle nut (3) from toe control link (2).
3. Repeat Steps (1) and (2) for opposite end of toe control link (2).

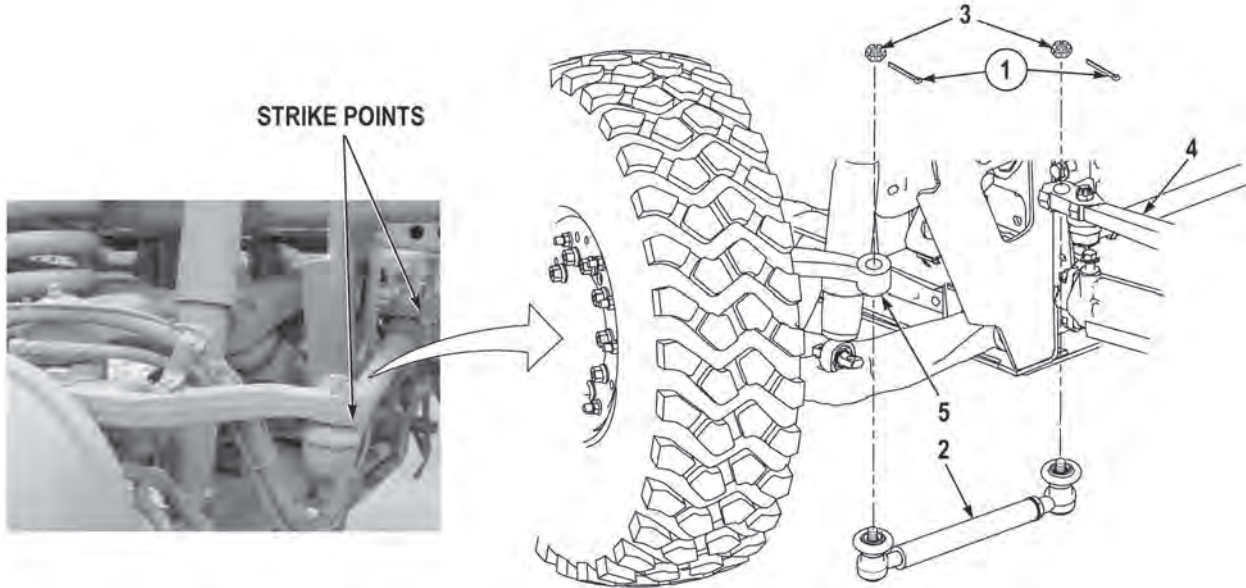

### **CAUTION**

**Do not use a removal tool to aid in removal of toe control link from steering arm. Failure to comply may result in damage to dust cover.**

### **NOTE**

- When removing inner toe control link, install castle nut flush with top threads on link.
  - A large pry bar may need to be used to apply pressure between frame and top of castle nut.
  - Note position of toe control link prior to removal to ensure proper installation.
4. Using a hammer, strike end or arm at strike point and remove toe control link (2) from pitman arm (4) and steering arm (5).

**END OF TASK**

**INSTALLATION****NOTE**

- Install toe control link in same position as noted prior to removal.
  - Both toe control links are installed the same way.
1. Install toe control link (2) on pitman arm (4) and steering arm (5) using two castle nuts (3).
  2. Tighten two castle nuts (3) to 145 lb-ft (197 N•m) and then continue to tighten until new cotter pins (1) can be installed.
  3. Install two cotter pins (1) on toe control link (2).
  4. Perform all Follow-On Maintenance tasks.

**END OF TASK****END OF WORK PACKAGE**





---

**TOE CONTROL LINK REPLACEMENT, AXLE NO. 2**

---

**Preconditions**

Park vehicle  
 Engine OFF  
 Wheels chocked

**Tools and Special Tools**

Tool Kit, General Mechanic's: Automotive  
 Wrench, Crowfoot Socket 1-7/16 in.  
 Wrench, Torque, 250 ft-lb

**Materials/Parts**

Pin, Cotter (2) (Item 1)

**Personnel Required**

Two

**Follow-On Maintenance**

Adjust steering alignment (axle No. 2)  
 Remove and stow wheel chocks

---

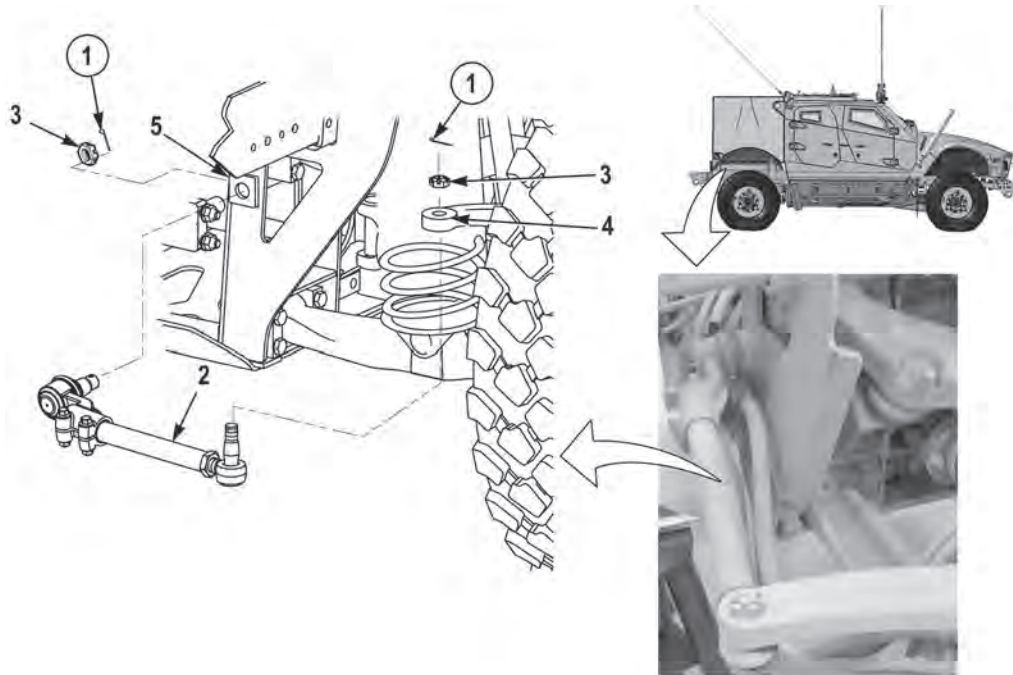
**REMOVAL****NOTE**

Both toe control links are removed the same way. Passenger side shown.

1. Remove two cotter pins (1) from toe control link (2). Discard cotter pins (1).
2. Remove two castle nuts (3) from toe control link (2).

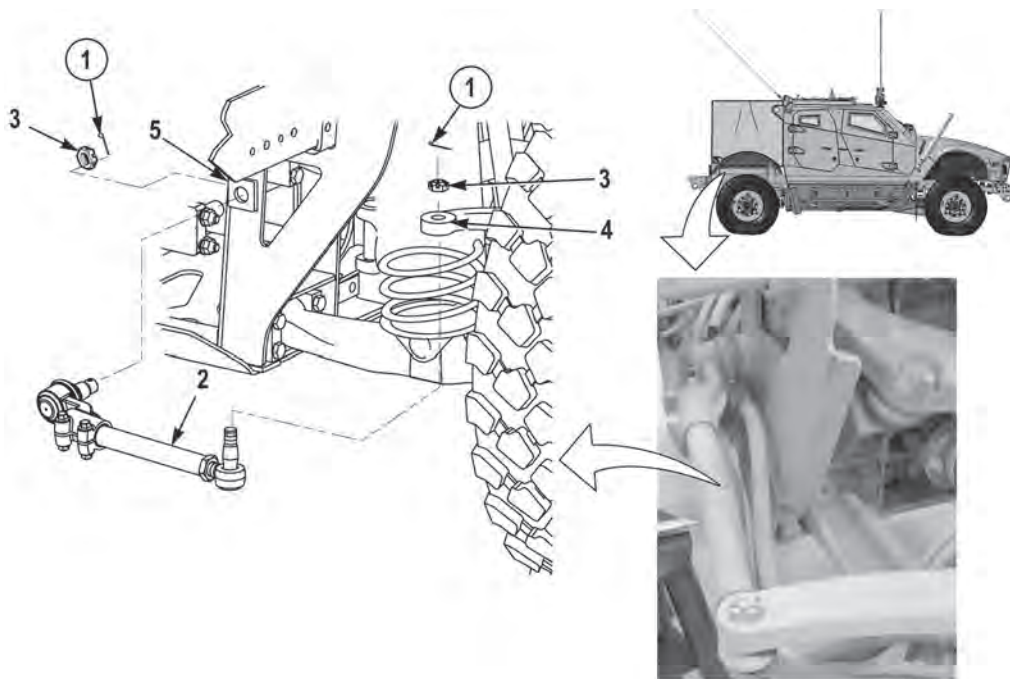

### **CAUTION**

**Do not use a removal tool to aid in removal of toe control link from steering arm. Failure to comply may result in damage to equipment.**

### **NOTE**

- To aid in removal, use an assistant and a pry bar to apply pressure between toe control link and steering arm while hammering on steering arm by toe control link. Use assistant and pry bar to apply pressure between toe control link and side plate while hammering side plate by toe control link.
- Note position of toe control link prior to removal to ensure proper installation.

3. Remove toe control link (2) from steering arm (4) and side plate (5).

### **END OF TASK**

### **INSTALLATION**

### **NOTE**

- Both toe control links are installed the same way. Passenger side shown.
- Install toe control link as noted prior to removal.

1. Install toe control link (2) on side plate (5) and steering arm (4) with two castle nuts (3).

**WARNING**

**When tightening castle nut, do not loosen castle nut to install cotter pin. Continue to tighten castle nut until cotter pin can be installed. Failure to comply may result in injury or death to personnel.**

2. Tighten two castle nuts (3) to 145 lb-ft (197 N•m), then continue to tighten until new cotter pins (1) can be installed.
3. Install two cotter pins (1) on toe control link (2).
4. Perform all Follow-On Maintenance tasks.

**END OF TASK**

**END OF WORK PACKAGE**



---

## UPPER STEERING SHAFT REPLACEMENT

---

**Preconditions**

Park vehicle  
 Engine OFF  
 Wheels chocked

**Tools and Special Tools**

Tool Kit, General Mechanic's: Automotive  
 Wrench, Torque 20 to 100 ft-lb

**Materials/Parts**

Lockwasher (3) (Item 5)  
 Locknut (5) (Item 8)

**Materials/Parts (continued)**

Lockwasher (3) (Item 12)  
 Locknut (Item 14)  
 Locknut (Item 19)  
 Locknut (3) (Item 24)  
 Compound, Sealing, Loctite 242

**Follow-On Maintenance**

Remove and stow wheel chocks

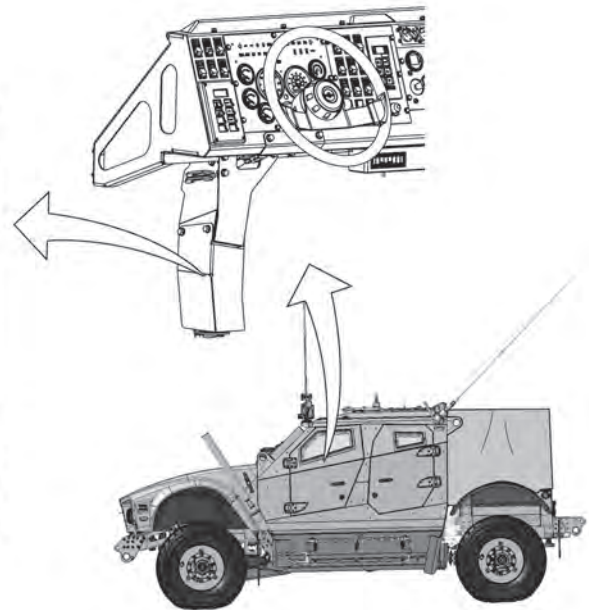
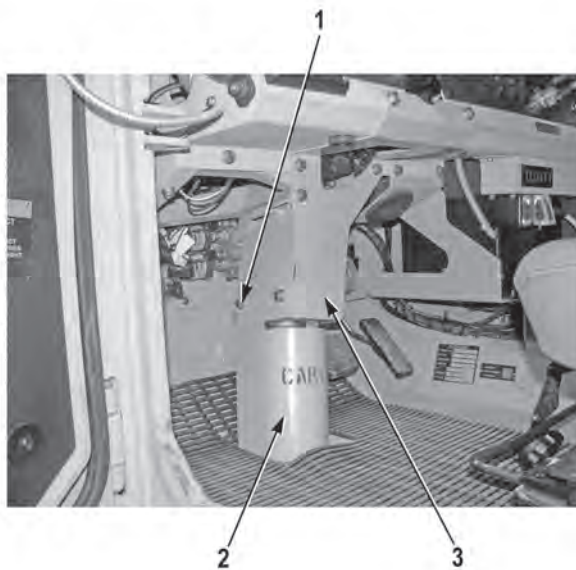
**REMOVAL****NOTE**

- Ensure vehicle wheels are aligned straight ahead before beginning procedures.
- Do not allow steering wheel to turn once universal joint is removed or misalignment may occur.
- Note position of upper steering shaft prior to removal to ensure proper installation.

1. Remove four screws (1) and steering shaft bracket (2) from steering column mounting bracket (3).



2. Remove three screws (4), lockwashers (5), and washers (6) from steering lock weldment (7). Discard lockwashers (5).

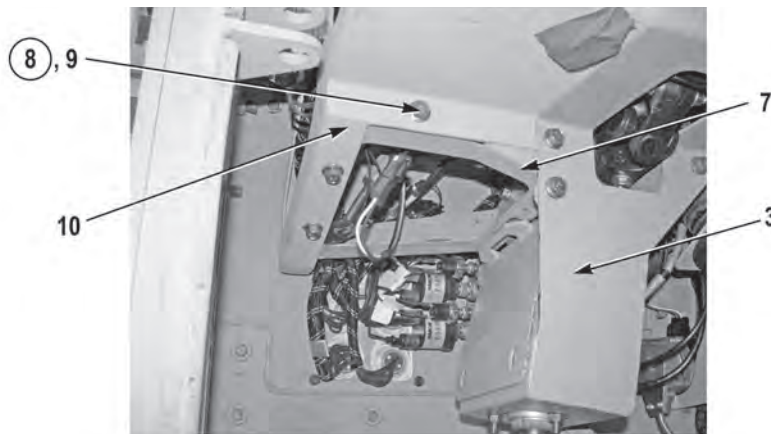

3. Remove five locknuts (8), screws (9), and steering lock weldment (7) from dash (10) and steering column mounting bracket (3). Discard locknuts (8).

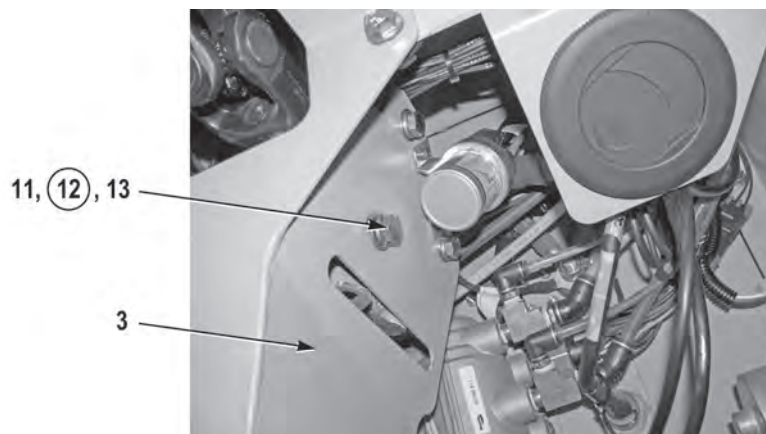

4. Remove three screws (11), lockwashers (12), and washers (13), from steering column mounting bracket (3). Discard lockwashers (12).



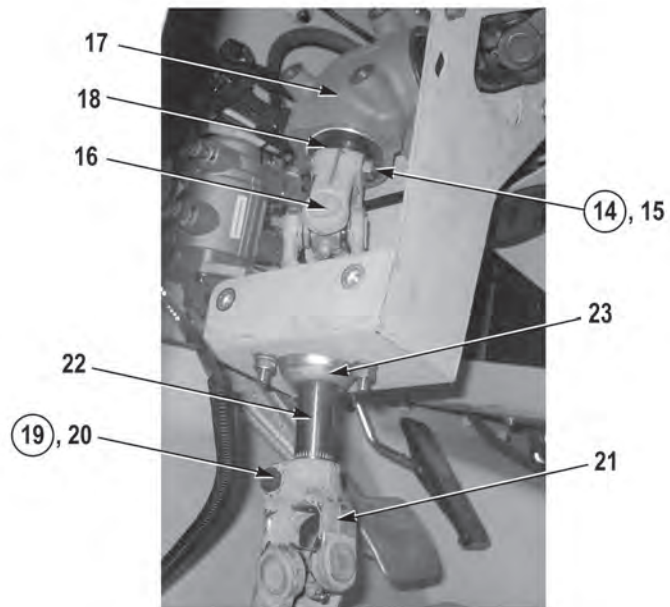

5. Remove locknut (14) and screw (15) from universal joint (16). Discard locknut (14).
6. Remove mitre box (17) and lock bracket (18) from universal joint (16).
7. Remove locknut (19) and screw (20) from universal joint (21). Discard locknut (19).
8. Remove upper steering shaft (22) from universal joint (21) and center bearing (23).

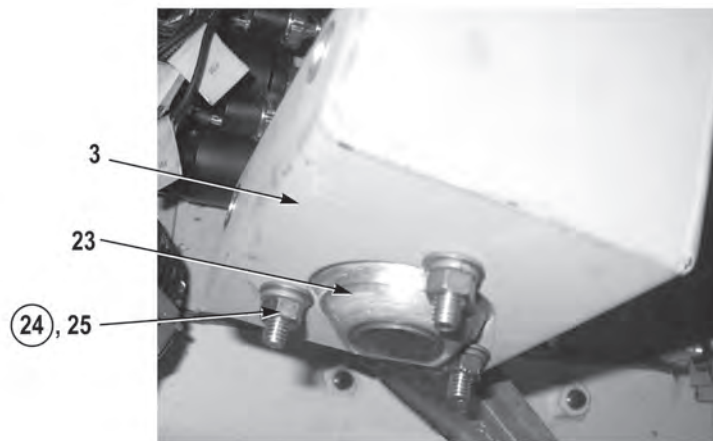

9. Remove three locknuts (24), screws (25), and center bearing (23) from steering column mounting bracket (3). Discard locknuts (24).

**END OF TASK**

## INSTALLATION

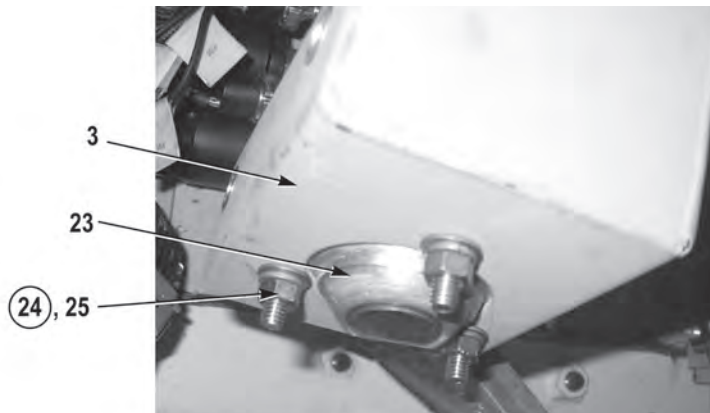

### NOTE

- Install upper steering shaft as noted prior to removal.
- Steering shafts are aligned correctly when spokes on steering wheel are parallel to bottom of dash and tires are pointed straight ahead.

1. Install center bearing (23) on steering column mounting bracket (3) with three screws (25) and new locknuts (24). Do not tighten screws (25).

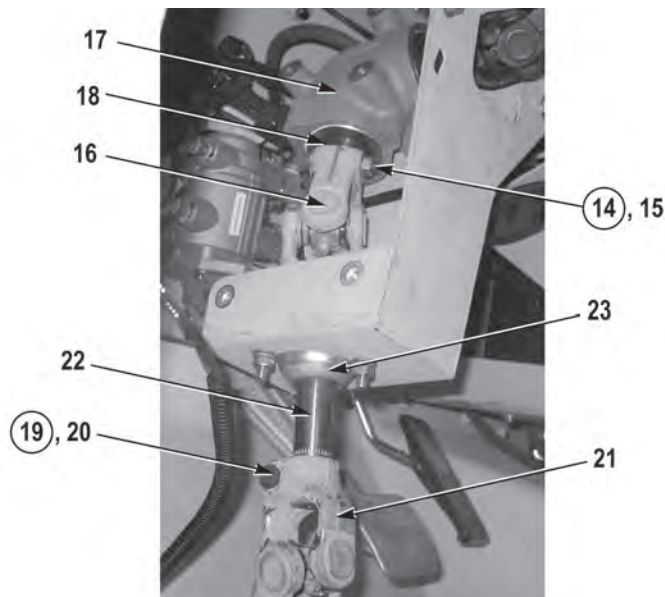

2. Install upper steering shaft (22) in bearing (23) and universal joint (21).
3. Secure upper steering shaft (22) to universal joint (21) with screw (20) and new locknut (19). Tighten locknut (19) to 40 lb-ft (54 N•m).
4. Install mitre box (17) and lock bracket (18) on universal joint (16) with screw (15) and new locknut (14). Tighten locknut (14) to 40 lb-ft (54 N•m).
5. Tighten screws (25).

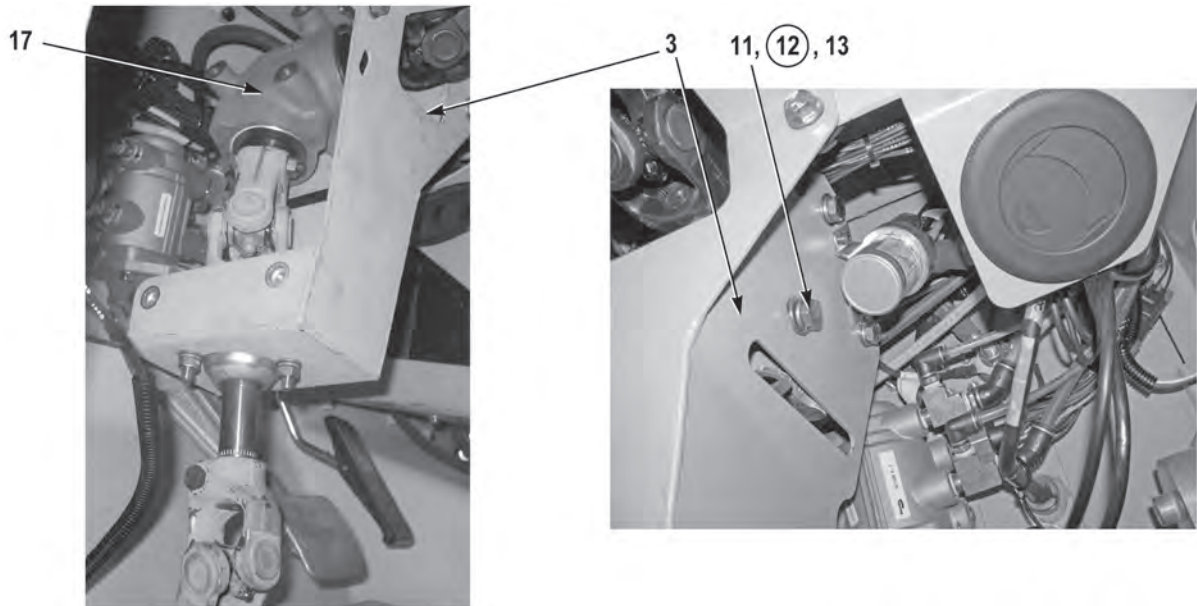

6. Install mitre box (17) on steering column mounting bracket (3) with three washers (13), new lockwashers (12), and screws (11).

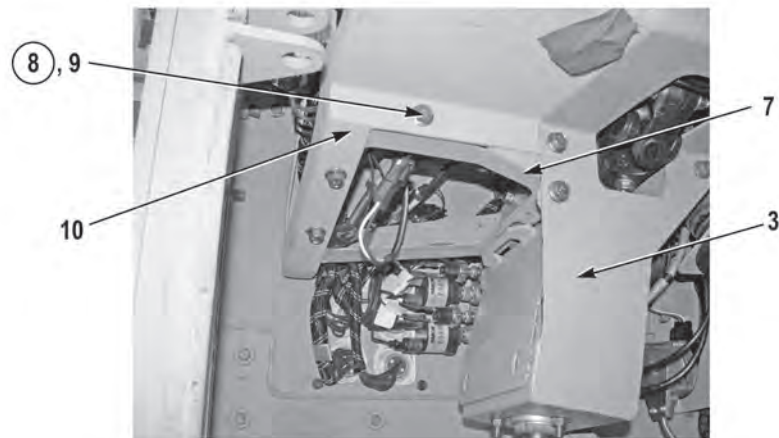

7. Install steering locking weldment (7) on dash (10) and steering column mounting bracket (3) with five screws (9) and new locknuts (8).



8. Install three washers (6), new lockwashers (5), and screws (4) on steering lock weldment (7).

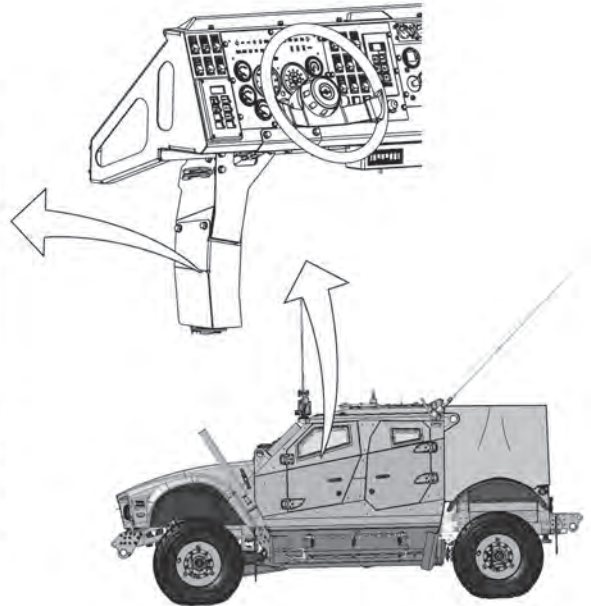
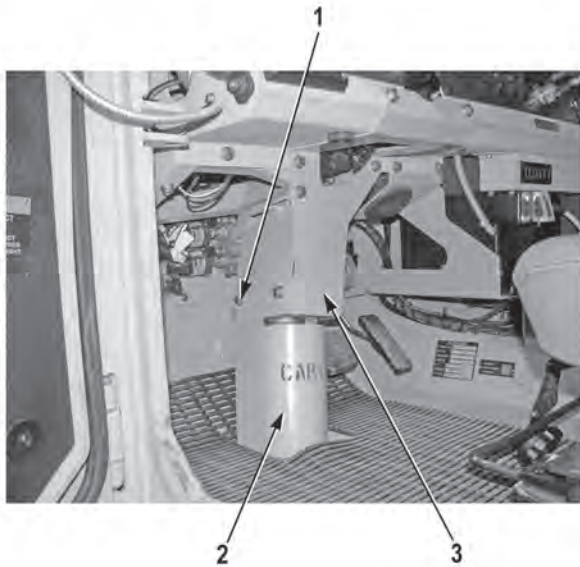

### **WARNING**

Adhesives, solvents, and sealing compounds can burn easily, can give off harmful vapors, and are harmful to skin and clothing. To avoid injury or death, keep away from open fire and use in well-ventilated area. If adhesive, solvent, or sealing compound gets on skin or clothing, wash immediately with soap and water. Failure to comply may result in injury or death to personnel.

9. Apply sealing compound, Loctite 242, to threads of four screws (1) and install steering shaft bracket (2) on steering column mounting bracket (3) with four screws (1).

**END OF TASK**

**END OF WORK PACKAGE**

---

## GENERAL MAINTENANCE

---

### INTRODUCTION

This chapter includes Field Maintenance instructions for removing, repairing, installing, and adjusting components necessary to maintain the MRAP - All Terrain Vehicle (M-ATV).

### GENERAL MAINTENANCE PROCEDURES

1. General Removal Instructions.
  - a. **Work required.** Remove only those parts needing repair or replacement. Do not disassemble a component any further than needed.
  - b. **Preparation.** Before removing any part of the electrical or air systems, make certain system is not energized or pressurized. Disconnect battery cables. Relieve all pressure from air system. Make sure brakes are applied and that all controls are in OFF position before starting any removal procedure.
  - c. **Removal.** Make sure there is enough clearance to remove part. Disassemble MRAP - All Terrain Vehicle (M-ATV) or adjacent parts as needed to provide working clearance.
  - d. **Lifting.** Always use chain hoist, jack, or other aid when lifting heavy parts. Make certain, load limit of lifting device exceeds weight being lifted. Position and rig lifting device before disconnecting part for removal.
  - e. **Identification.** Tag or mark all similar parts, such as electrical leads, before disconnecting and removing. This will make proper assembly easier. Be sure to identify mating ends of electric connectors and air lines as they are disconnected.
  - f. **Hoses.** Cap and plug all hoses and fittings upon removal.
2. General Disassembly Instructions.
  - a. **Cleanliness.** Work area must be kept as clean as possible. This will prevent contamination of internal parts. This is especially true for valves, cylinders, or air system parts.
  - b. **Expendable Parts.** All gaskets, packings, and seals removed during repair must be discarded and replaced with new parts. These items are usually damaged during removal. In the same way, all lockwire, lockwashers, locknuts, cotter pins, and like items must be replaced at time of assembly.
  - c. **Removing Seals.** When removing gaskets, packings, or seals, do not use any metal tool that will scratch the surfaces that will mate with these items. Replace all seals upon removal.
  - d. **Disassembly.** Before disassembly of any item, study illustration carefully. Note relationship of internal parts. Knowing details of a component will speed up disassembly and assembly, and will help avoid mistakes.
  - e. **Parts Protection.** To prevent moisture and dirt from entering open housings, lines, or other openings, apply protective caps and plugs as soon as possible after disassembly.



---

3. General Cleaning Instructions.

**WARNING**

Clean up all fluid spills to prevent slip and fire hazards. Dispose of material in accordance with local hazardous waste disposal procedures. Failure to comply may result in injury to personnel and damage to the environment.

**WARNING**

Solvent cleaning compound MIL-PRF-680 Type II and III may be irritating to the eyes and skin. Use protective gloves and goggles. Use in well-ventilated areas. Use respirator as needed. Accidental ingestion can cause irritation of digestive tract and respiratory tract, may cause lung and central nervous system damage. Can be fatal if swallowed. Inhalation of high/massive concentrations can cause coma or be fatal. First aid for ingestion: do not induce vomiting. Seek immediate medical attention. First aid for skin contact: remove contaminated clothing. Wash skin thoroughly with soap and water. If symptoms persist, seek medical attention. First aid for eye contact: flush with water for 15 minutes or until irritation subsides. If symptoms persist, seek medical attention. First aid for inhalation: move to fresh air. If not breathing, provide artificial respiration. If symptoms persist, seek medical attention. Keep away from open flames and other flames and other sources of ignition. Failure to follow this warning may result in injury or death to personnel.

- The flashpoint for Type II solvent cleaning compound is 141 to 198°F (61 to 92°C) and Type III is 200 to 241°F (93 to 116°C).
- Do not use improper cleaning methods or unauthorized cleaning solvents. Failure to comply may result in injury or death to personnel and damage to equipment.
- Fire extinguishers should be placed nearby when using solvent cleaning compound. Failure to comply may result in injury or death to personnel.
- Cloths or rags saturated with solvent cleaning compound must be disposed of IAW authorized facility's procedures. Failure to comply may result in injury to personnel.
- Eye shields must be worn when cleaning with a wire brush. Flying rust and metal particles may be present. Failure to comply may result in injury or death to personnel.
- Never use fuel to clean parts. Fuel is highly flammable. Fuel may ignite during cleaning. Failure to comply may result in injury or death to personnel.
- Compressed air used for cleaning purposes will not exceed 30 psi (207 kPa). Use only with effective chip guarding and personnel protective equipment (goggles/shield, gloves, etc). Failure to comply may result in injury to personnel.



---

### **CAUTION**

**Do not clean tires, rubber hoses, or electrical components with solvent mixture. Failure to comply may result in damage to equipment.**

- a. **Removing Deposits.** After soaking parts in a solvent, remove deposits by flushing or spraying. When necessary, brush with a soft-bristle brush moistened in solvent. Use compressed air to dry all parts, except bearings. Bearings must be allowed to air dry.
- b. **Tools.** Do not use scrapers, wire brushes, abrasive wheels, or compounds when cleaning parts, unless called for in detailed instructions. These procedures may weaken a highly stressed part.
- c. **Ball and Roller Bearings.** When cleaning ball or roller bearings, place them in a basket and suspend them in a container of solvent. If needed, use a brush to remove caked grease, chips, etc. Avoid rotating bearings before solid particles are removed to prevent damaging races and balls. When bearings have been cleaned, coat them lightly with lubrication oil to remove solvent.
- d. **Rubber Parts.** Do not clean rubber parts in solvent. These parts should be wiped clean with a clean, dry, lint-free cloth.

### **WARNING**

**Steam cleaning creates hazardous noise levels and severe burn potential. Eye, skin, and ear protection are required. Failure to comply may result in injury to personnel.**

- e. **Exterior Parts.** Steam clean all exterior parts thoroughly before removing. This will make inspection and disassembly easier.

### **WARNING**

**Solvents used with a spray gun must be used in a spray booth with filter. Face shield must be used by personnel operating spray gun. Failure to comply may result in injury to personnel.**

- f. **Engine, Capsule Exterior, Body.** Use a high pressure washer for cleaning exterior of engine, capsule, and body. Rinse with hot water, if available. An ordinary garden hose with nozzle may be used if other equipment is not available. Rinse thoroughly.

---

**WARNING**

Adequate ventilation shall be provided while using solvents and cleaners. Prolonged breathing of vapors should be avoided. Do not use near heat or open flame. Avoid prolonged contact with skin. Use of rubber gloves conforming to FED SPEC ZZ-G-281, face shield conforming to L-F-36, and other protective equipment are required according to OSHA Standard. Failure to comply may result in injury or death to personnel.

**CAUTION**

- **When using a pressure washer to clean vehicle, do not allow water stream to contact dash, dash components, or other electrical components. Failure to comply may result in damage to equipment.**
  - **When using a pressure washer to clean capsule interior, keep nozzle of pressure washer away from vehicle or components a distance of 5 ft. (1.5 m) or more. Failure to comply may result in damage to equipment.**
  - **Do not spray cleaning solvent on the front of the dash panels or gauges. This can cause discoloration and clouding of dash panels and gauges. Failure to comply may result in damage to equipment.**
- g. **Capsule Interior.** Using clean cloth, wipe loose dust and dirt from capsule interior. Clean seats and seat belts using a mild solution of warm water and soap solution. Never use solvents or abrasives. Using clean, dry cloth, wipe seats and seat belts dry.
- h. **Degreasing Machine.** A degreasing machine may be used to remove heavy grease and oil accumulation from metal parts.
- i. **Passages.** After removing parts from degreasing machine, and before coating with rust preventive, check all oil passages and cavities for dirt or blockage. A thin, flexible wire should be run through oil passages to make certain that they are not clogged. Individual passages that are dirty may be cleaned using a pressure spray gun and dry cleaning solvent.

**WARNING**

**Ensure battery disconnect switch is in OFF position. Failure to comply may result in injury or death to personnel.**

- j. **Electrical Parts.** Electrical parts such as coils, junction blocks, switches, and igniters, which use insulation materials, should not be soaked or sprayed with cleaning solutions. Clean these parts with a clean, lint-free cloth moistened with solvent or contact cleaner. Cleaning solvent, contact cleaner, and wire terminals may be used to clean noninsulated, electrical contacts, switches, relays, and wire terminals.

- k. **Ground Connectors.** It is required that ground wire, cable, and strap connections are made on a clean, bare metal surface, ensuring metal-to-metal contact. All paint, lacquer, oxides, corrosion, oils, and grease must be removed prior to attachment of wires, cables, or straps. Metal surfaces must be spot-faced to base metal to provide proper grounding.

### CAUTION

**Avoid excess removal of surface finish to adjacent area. Failure to comply may result in damage to equipment.**

Paint removal is to be made in a uniform, circular diameter to allow full contact to base metal. Where surface preparation has been made and preserved, using adhesive-backed tapes or like items, it is necessary that the grounding surface be cleaned prior to final assembly. If metal surface has been exposed to elements where oxidation, corrosion, or contamination may have taken place, it is required that the surface be cleaned and prepared prior to final assembly.

Once ground connections have been secured, RTV sealant must be applied to ends of ground wire, cable, or straps and any exposed bare metal surfaces to prevent oxidation, corrosion, or contamination.

**Table 1. Recommended Spot-Face Diameters.**

Wire Gauge	Nominal Fastener/Hole Size			
	#10	1/4 in.	5/16 in.	3/8 or 1/2 in.
18 - 14	1/2 in.	5/8 in.	3/4 in.	1 in.
12 - 10		5/8 in.	3/4 in.	1 in.
8		5/8 in.	3/4 in.	1 in.
6			3/4 in.	1 in.
4			3/4 in.	1 in.
2			3/4 in.	1 in.
1			3/4 in.	1 in.
1/0			3/4 in.	1 in.
2/0				1 in.
3/0				1 in.
4/0				1 in.

- l. **Ground Straps.** This vehicle is equipped with extra grounding protection to ensure proper and safe operation of all electronic equipment in addition to normal ground wires and cables. There are several ground straps located throughout this vehicle. They can be identified by the flat, braided wire between the connection points of the strap as illustrated below.

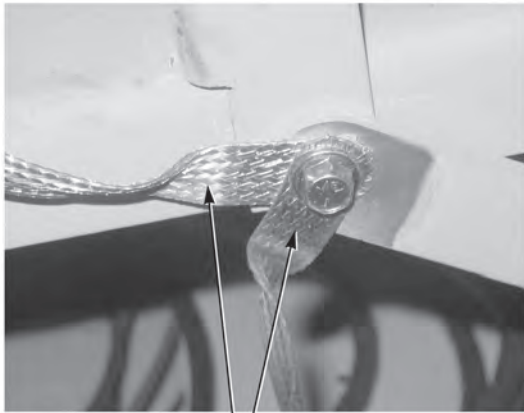

GROUND STRAPS

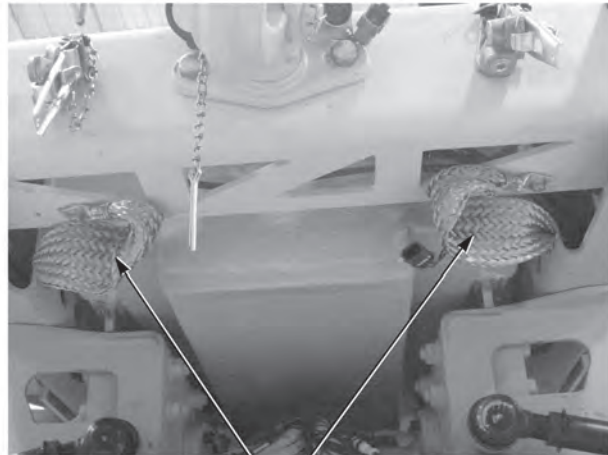

GROUND STRAPS

### CAUTION

**Do not use soap or alkalis for cleaning tank interiors. Failure to comply may result in damage to equipment.**

- m. **Fuel Tanks.** Pay special attention to all warnings and cautions when working on vehicle's fuel tank. Fuel tanks should be flushed, using a spray gun and cleaning solvent.
- n. **Battery.** Exterior surfaces of the electrical system and battery should be cleaned with a weak solution of baking soda and water. Apply solution with a bristle brush to remove any corrosion.
4. General Inspection Instructions.
- a. **Sealing Surfaces.** Inspect all surfaces in contact with gaskets, packings, or seals. Make sure there are no nicks, burns, or scratches. If any defect is found, remove or repair part as required.
- b. **Bearings.** Check bearings for rusted or pitted balls, races, or separators. Check balls and races for brinelling, abrasion, and serious discoloration. Following are causes for bearing rejection:
- Cuts or grooves parallel to ball or roller rotation.
  - Fatigue pits (not minor machine marks or scratches).
  - Cracks.
- c. **Inspection.** Inspection consists of checking for defects such as distortion, wear, cracks, and pitting. Parts under heavy load or pressure must be inspected more thoroughly. Clean all parts before inspection.

- 
- d. **Drain Plugs.** When removing drain plugs from transmission, engine, or steering system components, inspect sediment adhering to plug. A build-up of grit and/or fine metal particles may indicate part failure. A few fine particles are normal. This inspection is effective in determining defective parts prior to internal inspection of parts.
- e. **Gears.** Gear inspection cannot be described in detail here. There are too many differences in size and shape of gears. The following inspection can be used to make a general visual inspection of all gears. Follow all steps listed within repair inspection of parts.
- **Normal Wear.** Loss of metal from the surface of gear teeth. Wear must not prevent gears from meshing or performing properly.
  - **Initial Pitting.** This may occur when a pair of gears is first started in service. It may continue until most high spots have been reduced. As long as contact surfaces are not affected, this pitting is not necessarily serious.
  - **Destructive Pitting.** This type of pitting occurs after initial pitting, often at an increasing rate. This will destroy contact area and reduce gear's ability to carry a load. Rapid destruction will occur with use.
  - **Abrasive Wear.** This damage is caused by fine particles carried in the lubricant or imbedded in the gear teeth. These particles may come from many sources; metal detached from gear teeth or bearings, abrasives not completely removed before assembly, sand or scale from castings, or other impurities in oil or air.
  - **Scoring.** Burning or scoring is indicated by discoloration and loss of hardness due to excessive temperature. This is caused by too much friction resulting from overload, overspeed, lack of backlash, or faulty lubrication. If discoloring can be wiped off with clean cloth, such discoloring usually can be traced to oil burn-stains, which are not serious.
  - **Rolling.** This damage occurs mainly on plastic gears. Rolling occurs when material is pushed out of shape without breaking off. This is caused by heavy, uneven loads, sliding, or overheating.
  - **Brinelling.** This can be identified by tiny indentations or ridges on the shoulder or race of a bearing.
- f. **Splines.** Inspect shaft splines for wear, pitting, rolling, peening, and fatigue cracks. In many cases, the same inspection procedure will apply to gears. However, the problem, if present, will often be much less pronounced. Have a magnetic particle inspection performed on splines if needed.
- g. **Tubing and Hose.** Check all hose surfaces for broken or frayed fabric. Check for breaks caused by sharp kinks or rubbing against other parts of the vehicle. Inspect stainless steel lines for kinks. Inspect fitting threads for damage. All O-rings must be removed and new ones installed when any hose or tubing connection is disconnected. Replace any part found defective. Following assembly and during initial MRAP M-ATV operation, check for leaks.
- h. **Electrical Parts.** Inspect all wiring harnesses for chafed or burned insulation. Inspect all terminal connectors for loose connections and broken parts.
- i. **Metal Parts.** Visually inspect all castings and weldments for cracks. Parts that carry a great load should receive magnetic particle inspection. Critical nonferrous parts may be inspected with fluorescent penetrant.

---

5. General Repair Instructions.

**WARNING**

**Drilling and grinding operations are hazardous to the eyes. Eye protection is required. Failure to comply may result in injury to personnel.**

- a. **Burrs.** Remove burrs from gear teeth with a fine-cut file or hand grinder.
- b. **Exterior Parts.** Exterior painted parts may be resurfaced where paint is damaged, or where parts have been repaired, by using an abrasive disc.
- c. **Bearings.** Remove residue and oil stain from bearing races with crocus cloth.
- d. **Protective Parts.**

**NOTE**

This procedure is used with polished and machined steel parts not protected by cadmium, tin, or other plating or surface treatment. Bare metal surfaces must be free of moisture when protective coating is applied.

During repair operations, protect bare steel surfaces from rusting when not actually undergoing repair work. Dip parts in, or spray them with, corrosion-preventive compound. The same protective coating may be applied to other metals to prevent rust. Aluminum parts may require protection in atmospheres having a high salt content. Steel parts must always be protected.



e. **Threaded Inserts.****CAUTION**

**When drilling out threaded insert, do not enlarge existing hole. The new threaded insert will not seat properly if hole is enlarged. Failure to comply may result in damage to equipment.**

**NOTE**

- All threaded inserts are replaced the same way.
- When replacing threaded inserts, use Twist Drill table to determine which twist drill to use.

**Table 2. Twist Drill.**

<b>PART NUMBER</b>	<b>TWIST DRILL SIZE (IN.)</b>
ALS7-1024-130	1/4
ALS7-1024-130	1/4
ALS7-420-165	3/8
ALS7-1024-225	1/4
ALS7-616-150	1/2
ALS7-420-260	3/8
ALS7-518-150	13/32
ALS7-518-312	13/32

- (1) Drill out damaged threaded insert.

**CAUTION**

**Do not over tighten threaded insert. Failure to comply may result in damage to equipment.**

**NOTE**

Use Tool Kit Blind Fastener from SATS to install threaded inserts.

- (2) Using installation tool, insert new threaded insert into hole and install threaded insert until it is fully seated.

---

f. **Welding.**

**WARNING**

M-ATV is equipped with a capsule interior automatic fire suppression system. Before performing any welding, brazing, grinding, or using open flame in capsule, batteries must be disconnected. In addition, the maintenance circuit breaker located to the right of the main circuit breaker in the dash must be pulled out to prevent accidental activation of automatic fire suppression system in the capsule. System components must also be covered. Failure to comply may result in injury to personnel.

**WARNING**

M-ATV is equipped with an engine compartment fire suppression system. Before performing any welding, brazing, grinding operation, or using open flame in engine compartment, batteries must be disconnected. In addition, the automatic fire suppression system for the engine compartment must be disabled to prevent accidental activation of automatic fire suppression system. System components must also be covered. Failure to comply may result in injury to personnel.

**WARNING**

M-ATV is equipped with an undercarriage fire suppression system designed to extinguish fires in all wheel wells and in fuel tank area. Before performing any welding, brazing, grinding operation, or using open flame in or around the wheel well/fuel tank areas, batteries must be disconnected. In addition, the automatic fire suppression system for the undercarriage must be disabled to prevent accidental activation of automatic fire suppression system. Care must be taken to prevent damage to any of the fire suppression sensor lines which, if damaged, may trigger automatic fire suppression system upon system being enabled. Undercarriage fire suppression system is triggered by loss of pressure in sensor lines. Failure to comply may result in injury to personnel.

**WARNING**

If welding, brazing, grinding, or open flame operations have been performed, any components subject to these operations must be allowed to cool before enabling automatic fire suppression system. Failure to comply may result in injury to personnel.

Welding and brazing may be used to repair cracks in external steel parts, such as brackets, panels, and light framework. These repairs should be made only when replacement parts are not available. Do not weld or braze castings, running parts, or parts under great stress except in emergencies.

- g. **Stud Installation.** When installing studs in engine block and axle housings, use a driver designed for the stud to be installed. A worn stud driver may damage the end thread. This makes it necessary to use a chasing die before a nut can be screwed on. This procedure will remove cadmium plating and allow corrosion. This will make future disassembly difficult and may cause stud to be backed out with nut. Before driving a stud, inspect hole for chips and liquid. Blow out any foreign matter. Start stud by hand. If it will not start into hole, it is too large or has defective end thread. Before final insertion, coat thread with anti-seize compound. Turn stud in slowly to prevent overheating and galling of casting metal.
  - h. **Electrical Parts.** Replace all broken, worn, or burned electrical wiring. Wires with several broken strands must be replaced. Broken strands will increase the resistance of the wire and impair efficiency of electrical components, especially the ignition system. Ensure connectors are clean before reconnecting connectors. Apply a light coating of Nyogel 760G to all electrical connectors before connector is reconnected (a light coating is all that is required).
  - i. **Hoses.** Replace all broken, frayed, crimped, or soft flexible lines and hoses. Replace stripped or damaged fittings. Replace entire flexible hose if fittings are damaged. Make sure hose clamps do not crimp hoses. All O-rings must be removed and new ones installed when any hose or tubing connection is disconnected.
  - j. **Fasteners.** Replace any bolt, screw, nut, or fitting with damaged threads. Inspect tapped holes for thread damage. If cross-threading or galling is evident, retap the hole for the next oversize screw or stud. When retapping will weaken the part, or when the cost of the part makes retapping impractical, replace the damaged part. Chasing threads with the proper size tap or die may often be enough.
  - k. **Dents.** Straighten minor body dents by bumping with a soft-faced hammer while using a wooden block backing.
  - l. **Sheet Metal Repair.** Repair minor skin cracks by installing patches.
  - m. **Mounting Holes.** Reshape oval mounting hole to round. Drill to receive bushing with required inner diameter. Stake bushing in place with center punch.
6. General Assembly Instructions.
- a. **Preparation.** Remove grease from new parts before installation.
  - b. **O-ring Installation.** Lubricate all O-rings with a thin coating of light mineral oil before installation. Slightly stretch packing and place into position. Rotate component on flat surface or uniformly press the packing into position.
  - c. **Gaskets.** To provide added sealing for gasket, coat both sides with sealant. Remove all traces of previous gasket and sealant before installing new gasket.

### **WARNING**

**On direct contact, uncured silicone sealant irritates eyes. In case of contact, flush eyes with water and seek medical attention. Avoid prolonged contact with skin. Failure to comply may result in injury or death to personnel.**

- d. **Silicone Sealant.** Silicone sealant is often used instead of a gasket to seal mating parts. The mating parts must be clean, dry, and free of oil or grease for proper adhesion. Silicon starts to set-up in 15 minutes and takes 24 hour to completely cure. Excess silicone sealant should be wiped off after disassembling the mating parts.

- 
- e. **Oil Seals.** Install oil seals with seal lip facing towards lubricant, applying an even force to outer edge of seal. Coat oil seals evenly with grease before installing. If oil seals will be installed over keyed or splined shafts, use a guide. This will prevent sharp edge of keyway of splines from cutting the leather or neoprene seal. Construct guides of very thin gage sheet metal and shape to required diameter. However, make certain guide edges are not sharp. Bend them slightly inward so they do not cut the seal.
  - f. **Seal Rings.** Coat seal rings with oil and carefully install into their bores. If seal rings must be installed over threaded parts, temporarily wrap the threads with tape to protect the seal ring, then remove the tape.
  - g. **Bearing and Shafts.** During assembly of shafts and bearings in housings, first mount bearing on shaft, then install the assembly by applying force to shaft. When mounting bearings on shafts, always apply force to the inner races of the bearing.
  - h. **Bearing Lubrication.** Lubricate bearings before reassembly with the type of lubricant normally used in the related housing or container. This will provide lubrication during the first run-in until lubricant from the system can reach the bearings.
  - i. **Fasteners.** When fastener tightening requirements are not given in the maintenance task, tighten screws and nuts in accordance with Torque Instructions (WP 0292). If a tightening sequence is required it will be given in the maintenance task.

**END OF TASK**

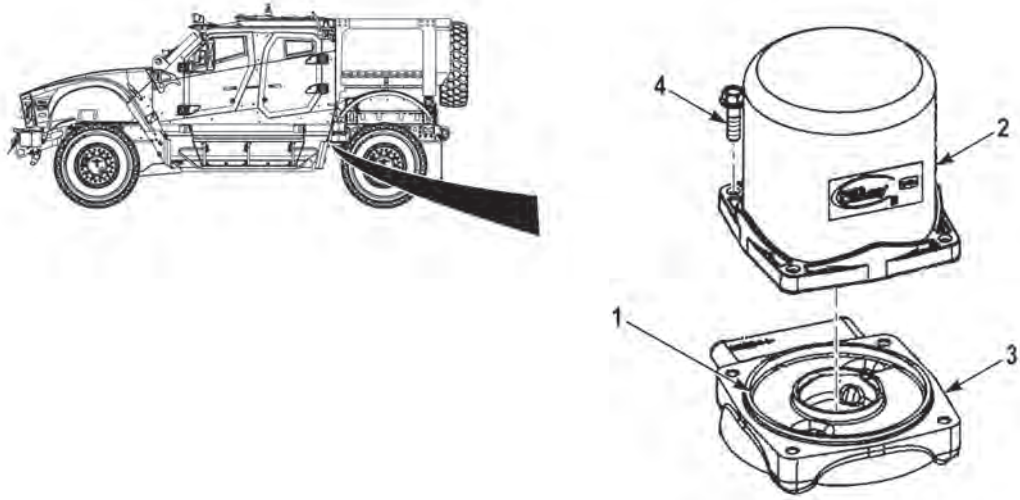
**AIR SYSTEM LEAK TEST****NOTE**

- Perform Step (1) if air dryer is removed from vehicle.
  - Reuse O-ring from air dryer removal for air system leak test only.
  - Use ball valve (16B100) and 90° fitting (3953273) for air system leak test.
1. Install O-ring (1) and canister (2) on air dryer base (3) with four screws (4).

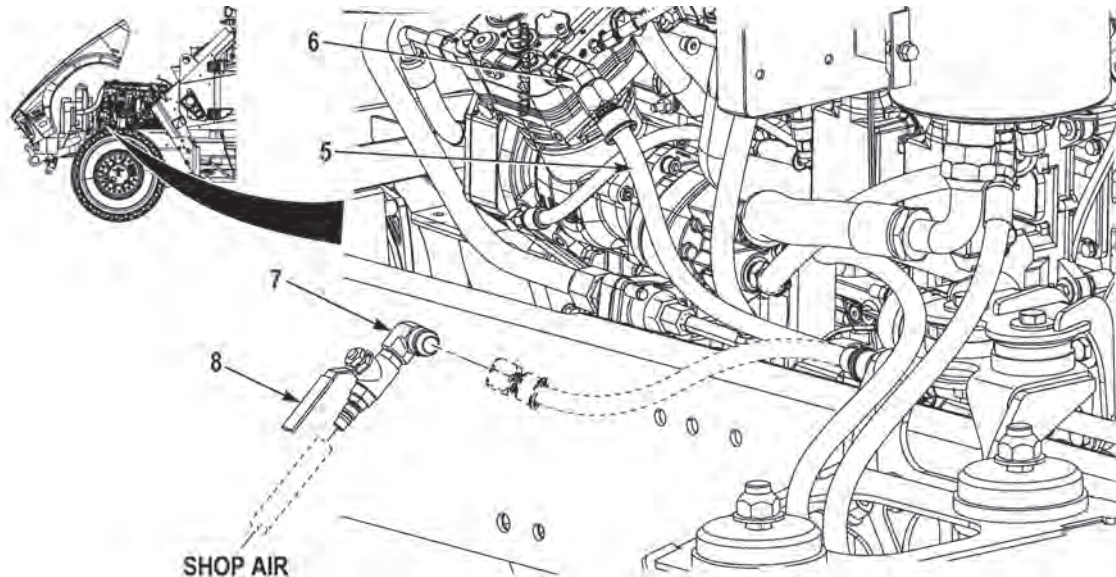

2. Remove hose assembly (5) from fitting (6).
3. Install fitting (7) on ball valve (8).
4. Install hose assembly (5) on fitting (7).

### NOTE

Ensure ball valve is in the closed position prior to installation.

5. Connect shop air to ball valve (8).
6. Slowly open ball valve (8).
7. Once the air dryer has purged, close ball valve (8).
8. Listen and inspect all air lines for leaks. If air leak(s) are present, perform corrective maintenance as required.
9. Disconnect shop air from ball valve (8).
10. Remove hose assembly (5) from fitting (7).
11. Remove fitting (7) from ball valve (8).
12. Install hose assembly (5) on fitting (6).



**WARNING**

**Air system must be drained prior to removing air system components. Failure to comply may result in injury or death to personnel.**

13. Drain air system.

**NOTE**

Perform Steps (14) and (15) if air dryer was removed from vehicle.

14. Remove four screws (4), O-ring (1), and canister (2) from air dryer base (3). Discard O-ring.
15. Cover air dryer base (3) and canister (2) to prevent contamination.

**END OF TASK**

**END OF WORK PACKAGE**



---

## TORQUE INSTRUCTIONS

---

### TORQUE LIMITS FOR SCREWS

#### GENERAL

This section provides general torque limits for fasteners used on this vehicle. Special torque limits are indicated in the maintenance procedures for applicable components. The general torque limits given in this work package shall be used when specific torque limits are not indicated in the maintenance procedure. These general torque limits cannot be applied to screws that retain rubber components. The rubber components will be damaged before the correct torque limit is reached. If a special torque limit is not given in the maintenance instructions, tighten the screw or nut until it touches the metal bracket, then tighten it one more turn.

#### HOW TO USE TORQUE TABLE

Table 1 lists dry torque limits. Dry torque limits are used on screws that do not have lubricants applied to the threads. Table 2 lists wet torque limits. Wet torque limits are used on screws that have high-pressure lubricants applied to the threads. Table 3 lists torque limits for metric fasteners. Table 4 lists wet torque limits for Spirallock flange nuts (grade 8). All flange nuts used on this vehicle use Spirallock threads. Use the charts as follows:

1. Measure the diameter of the screw you are installing.

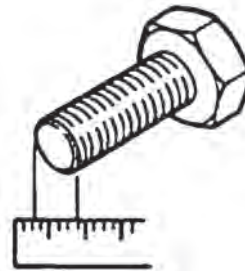

2. Count the number of threads per inch.
3. Under the heading SIZE, look down the left-hand column until you find the diameter of the screw you are installing (there will usually be two lines beginning with the same size).

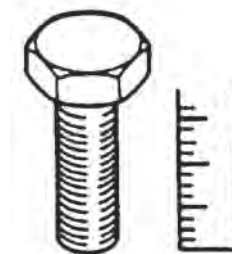

4. In the second column under SIZE, find the number of threads per inch that matches the number of threads you counted in Step (2).
5. To find the grade screw you are installing, match the markings on the head to the correct picture of CAPSCREW HEAD MARKINGS on the torque table.
6. Look down the column under the picture you found in Step (5) until you find the torque limit (in foot-pound or N•m) for the diameter and threads per inch of the screw you are installing.

**TORQUE LIMITS FOR FASTENERS**

*Table 1. Torque Limits for Dry Fasteners.*

**BOLT HEAD MARKINGS**

Manufacturer's marks may vary. Three of the markings on heads shown below, for example, indicate SAE Grade 5.



SIZE			TORQUE							
			SAE GRADE No. 1 or 2		SAE GRADE No. 5		SAE GRADE No. 6 or 7		SAE GRADE No. 8	
DIA INCHES	THREADS PER INCH	MILLIMETERS	POUNDS FEET	NEWTON METERS	POUNDS FEET	NEWTON METERS	POUNDS FEET	NEWTON METERS	POUNDS FEET	NEWTON METERS
1/4	20	6.35	5.5	7.5	8	10.8	10	13.6	12	16.3
1/4	28	6.35	6.3	8.5	10	13.6	12	16.3	14	19.0
5/16	18	7.94	11	15	17	23.1	21	28.5	25	33.9
5/16	24	7.94	12	16.3	19	25.8	24	32.5	25	33.9
3/8	16	9.53	20	27.1	30	40.7	40	54.2	45	61.0
3/8	24	9.53	23	31.2	35	47.5	45	61.0	50	67.8
7/16	14	11.11	30	40.7	50	67.8	60	81.4	70	94.9
7/16	20		35	47.5	55	74.6	70	94.9	80	108.5
1/2	13	12.70	50	67.8	75	101.7	95	128.8	110	149.2
1/2	20		55	74.6	90	122.0	110	149.2	120	162.7
9/16	12	14.29	65	88.1	110	149.2	135	183.1	150	203.4
9/16	18		75	101.7	120	162.7	150	203.4	170	230.5
5/8	11	15.88	90	122.0	150	203.4	190	257.6	220	298.3
5/8	18		100	135.56	180	244.1	210	284.8	240	325.4
3/4	10	19.05	160	217.0	260	352.6	320	433.9	380	515.3
3/4	16		180	244.1	300	406.8	360	488.2	420	569.5
7/8	9	22.23	140	189.8	400	542.4	520	705.1	600	813.6
7/8	14		155	210.2	440	596.6	580	786.5	660	895.0
1	8	25.40	220	298.3	580	786.5	800	1084.8	900	1220.4
1	12		240	325.4	640	867.8	860	1166.2	1000	1356.0
1-1/8	7	25.58	300	406.8	800	1084.8	1120	1518.7	1280	1735.7
1-1/8	12		340	461.0	880	1193.3	1260	1708.6	1440	1952.6
1-1/4	7	31.75	420	569.5	1120	1518.7	1580	2142.5	1820	2467.9
1-1/4	12		460	623.8	1240	1681.4	1760	2386.6	2000	2712.0
1-3/8	6	34.93	560	759.4	1460	1979.8	2080	2820.5	2380	3227.3
1-3/8	12		640	867.8	1680	2278.1	2380	3227.3	2720	3688.3
1-1/2	6	38.10	740	1003.4	1940	2630.6	2780	3769.7	3160	4284.9
1-1/2	12		840	1139.0	2200	2983.2	3100	4203.6	3560	4827.4

**Table 2. Torque Limits for Wet Fasteners.**

**BOLT HEAD MARKINGS**



Manufacturer's marks may vary. Three of the markings on heads shown below, for example, indicate SAE Grade 5.



SIZE			TORQUE							
			SAE GRADE No. 1 or 2		SAE GRADE No. 5		SAE GRADE No. 6 or 7		SAE GRADE No. 8	
DIA INCHES	THREADS PER INCH	MILLIMETERS	POUNDS FEET	NEWTON METERS	POUNDS FEET	NEWTON METERS	POUNDS FEET	NEWTON METERS	POUNDS FEET	NEWTON METERS
1/4	20	6.35	4	5.4	6.25	8.5	8	10.8	9	12.2
1/4	28	6.35	4.7	6.4	7	9.5	9	12.2	10	13.6
5/16	18	7.94	8	10.8	13	17.6	16	21.7	18	24.4
5/16	24	7.94	9	12.2	14	19.0	18	24.4	20	27.1
3/8	16	9.53	15	20.3	23	31.2	30	40.7	35	47.5
3/8	24	9.53	17	23.1	25	33.9	30	40.7	35	47.5
7/16	14	11.11	24	32.5	35	47.5	45	61.0	55	74.6
7/16	20		25	33.9	40	54.2	50	67.8	60	81.4
1/2	13	12.70	35	47.5	55	74.6	70	94.9	80	108.5
1/2	20		40	54.2	65	88.1	80	108.5	90	122.0
9/16	12	14.29	50	67.8	80	108.5	100	135.6	110	149.2
9/16	18		55	74.6	90	122.0	110	149.2	130	176.3
5/8	11	15.88	70	94.9	110	149.2	140	189.8	170	230.5
5/8	18		80	108.5	130	176.3	160	217.0	180	244.1
3/4	10	19.05	120	162.7	200	271.2	240	325.4	280	379.7
3/4	16		140	189.8	220	298.3	280	379.7	320	433.9
7/8	9	22.23	110	149.2	300	406.8	400	542.4	460	623.8
7/8	14		120	162.7	320	433.9	440	596.6	500	678.0
1	8	25.40	160	217.0	440	596.6	600	813.6	680	922.1
1	12		170	230.5	480	650.9	660	895.0	740	1003.4
1-1/8	7	25.58	220	298.3	600	813.6	840	1139.0	960	1301.8
1-1/8	12		260	352.6	660	895.0	940	1274.6	1080	1464.5
1-1/4	7	31.75	320	433.9	840	1139.0	1100	1491.6	1360	1844.2
1-1/4	12		360	488.2	920	1247.5	1320	1789.9	1500	2034.0
1-3/8	6	34.93	420	569.5	1100	1491.6	1560	2115.4	1780	2413.7
1-3/8	12		460	623.8	1260	1708.6	1780	2413.7	2040	2766.2
1-1/2	6	38.10	560	759.4	1460	1979.8	2080	2820.5	2360	3200.2
1-1/2	12		620	840.7	1640	2223.8	2320	3145.9	2660	3606.9



**Table 3. Torque Limits for Metric Fasteners.**

METRIC					OTC STD		OTC STD	
								
NOMINAL DIA -MM	PITCH -MM	NON STRESS AREA -MM	TENSILE STRENGTH (T) MIN PROOF LOAD (P) PSI		PROPERTY CLASS 8.8		PROPERTY CLASS 10.9	
			CLAMP LOAD LBS	ASSY TORQUE	CLAMP LOAD LBS	ASSY TORQUE		
			8.8 T/P	10.9 T/P	LUB FT-LBS	LUB FT-LBS		
6	1.00	20.1	113M/83M	142M/117M	1890	6	2560	8
7	1.00	28.9	"	"	2720	10	3830	15
8	1.25	36.6	"	"	3450	15	4850	20
10	1.50	58.0	"	"	5460	30	7680	40
12	1.75	84.3	"	"	7940	50	11170	70
14	2.00	115.0	"	"	10830	75	15230	110
16	2.00	157.0	"	"	14790	120	20800	170
20	2.50	245.0	"	"	23070	235	32460	330
24	3.00	383.0	"	"	33240	405	46760	570

**Table 4. Wet Torque Limits for Grade 8 Spirallock Flange Nuts.**

SIZE	THREADS PER INCH	TORQUE	
		POUNDS FEET	NEWTON METERS
1/4	20	15	20.3
5/16	18	25	33.9
3/8	16	44	59.7
1/2	13	107	145.1
5/8	11	212	287.5
3/4	10	375	508.5



## **TIGHTENING STANDARDS**

### **SCOPE**

This procedure is to set a standard for tightening fittings, tube/fittings, and hose assemblies. The torque values specified are from data compiled from tube, fitting, and equipment manufacturers and are recognized throughout the industry.





### **GENERAL**

The purpose of this procedure is to inform assembly personnel on the proper methods to tighten fittings, tube/fittings, and hose assemblies to achieve proper torques.

### **PROCEDURE**

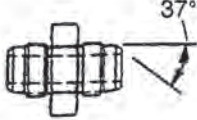
This attached procedure was developed by Oshkosh Corporation Engineering Department and should be followed for all vehicles manufactured at OSK.

**Table 5. Classification of Fittings.**

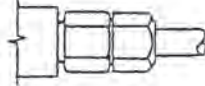
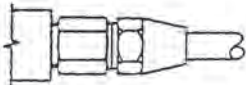
TYPE	FIGURE	SECTION NUMBER
SAE 37° Flare		G-3.a.
SAE "O" Ring Face Seal (ORFS)		G-3.b.
45° SAE Flare		G-3.c.
SAE Straight Thread "O" Ring		G-3.d. G-3.e.
Pipe Thread (NPTF)		G-4.
<b>BRASS COMPRESSION FITTINGS</b>		
NTA - Air Brake		G-5.a.
AB - Air Brake		G-5.b.

**ABBREVIATIONS**

AB - Air Brake

NFPA - SAE 37° Flare Swivel Connections

NPSM - American Standard straight pipe threads for free fitting mechanical joints (ANSI-B1-20-1)

NPTFT - Dryseal American Standard taper pipe thread (ANSI-B1-20-3)

NTA - Registered trademark of Parker Haninfin for SAE J844 compatible air brake tube fitting with tube supports

ORFS - O-ring face seal - SAE J1453

---

## GENERAL INSTRUCTIONS FOR ASSEMBLY OF TUBE TYPE FITTINGS

The successful operation of any system depends upon the care that is taken during its assembly.

- Take precautions to ensure that fittings and mating components are not damaged during storage, handling or assembly. Nicks and scratches in sealing surfaces can create a path for leaks which could lead to component contamination and or failure.
- When making a connection to tubing, compression or flare, inspect the tube in the area of fitting attachment to ensure that the tube has not been damaged. Damaged tubes, burrs, excessive paint can require excessive torque to tighten and can prevent a fitting from being properly tightened.

Always use two wrenches (when applicable) when installing or removing fittings, adapters, hoses, and air lines. Two wrenches are used to ensure the fitting being installed/removed does not affect the torque of the existing fitting/adapter. Always remove paint on fittings and adapters prior to removal. If paint is not removed, excess force must be exerted on adapters/fittings and may cause damage to component(s).

The assembly process is one of the leading causes for contamination in air and hydraulic systems. Contamination can prevent proper tightening of fittings and adapters from occurring.

- Avoid using dirty, oily rags when handling fittings.
- When it is required to disassemble fittings, the fittings should be cleaned and inspected for damage, and replaced, as necessary, before re-installing.
- Where specified, sealing compounds should be applied; however, caution should be taken not to introduce sealant into the system. Sealants can cause malfunction of components by blocking orifices and passages of valves.
- Avoid applying sealant to the area of the threads where the sealant will be forced into the system. (Generally, the first two threads of a fitting).
- Sealant should only be applied to the male threads.
- Straight fittings do not require sealants. O-rings or washers are provided for sealing.
- When replacing or installing O-rings, do not recklessly push the O-ring over the threads. O-rings could become nicked or torn. A damaged O-ring could lead to leakage problems. Use a thread protector when replacing O-rings on fittings.
- When installing O-rings, the O-rings should be lubricated to prevent scuffing or tearing from occurring.

Refer to the appropriate section of this standard for more specific instructions and procedures that should be followed.

**SAE 37° FLARE SWIVEL CONNECTIONS**

**a. SAE 37° Flare Swivel Connections Consist of the Following:**

- Machined adapters
- Hose fittings
- Flared tubes (sleeve and nut)
- Universal radius flared tubes

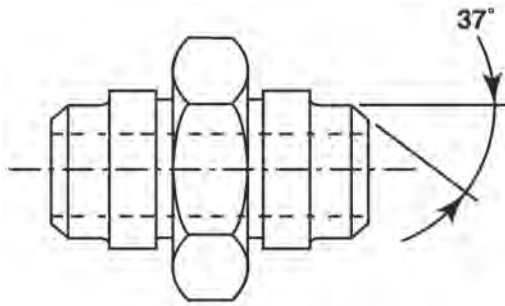

**Table 6. Torque Values for 37° Port and Swivel Connections.**

Tube Size	Thread Size	Torque Inch-Pounds	Torque Foot-Pounds
-4	7/16-20	135-145	11-12
-6	9/16-18	215-245	18-20
-8	3/4-16	430-470	36-39
-10	7/8-14	680-750	57-62
-12	1 1/16-12	950-1050	79-87
-14	1 1/16-12	1130-1240	93-103
-16	1 5/16-12	1300-1360	108-113
-20	1 5/8-12	1520-1600	127-133
-24	1 7/8-12	1900-2000	158-167
-32	2 1/2-12	2940-3100	245-258

b. ORS - O-ring Face Seal Connections

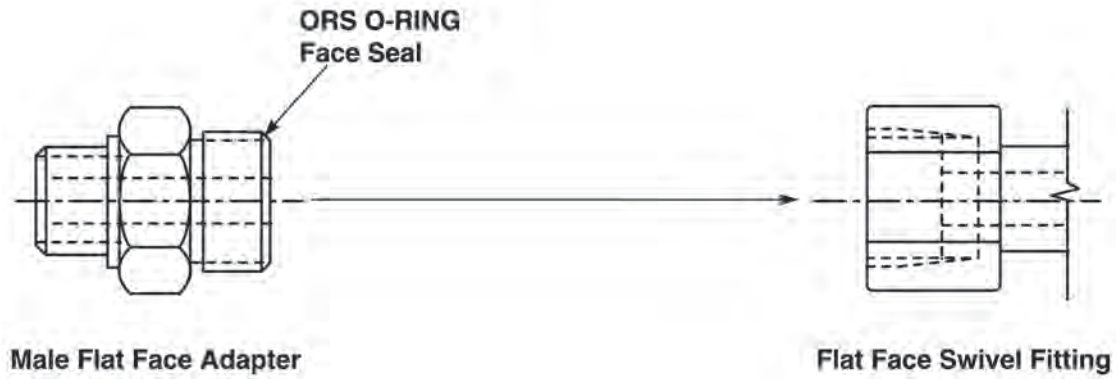

**Table 7. Torque Values for O-ring Face Seal Fitting Connections.**

Tube Size	Thread Size	Torque Inch-Pounds	Torque Foot-Pounds
-4	9/16-18	120-144	10-12
-6	11/16-16	216-240	18-20
-8	13/16-16	384-420	32-35
-10	1-14	552-600	46-50
-12	1 3/16-12	780-840	65-70
-16	1 7/16-12	1104-1200	92-100
-20	1 11/16-12	1500-1680	125-140
-24	2-12	1800-1980	150-165

c. 45° SAE Flare Connections

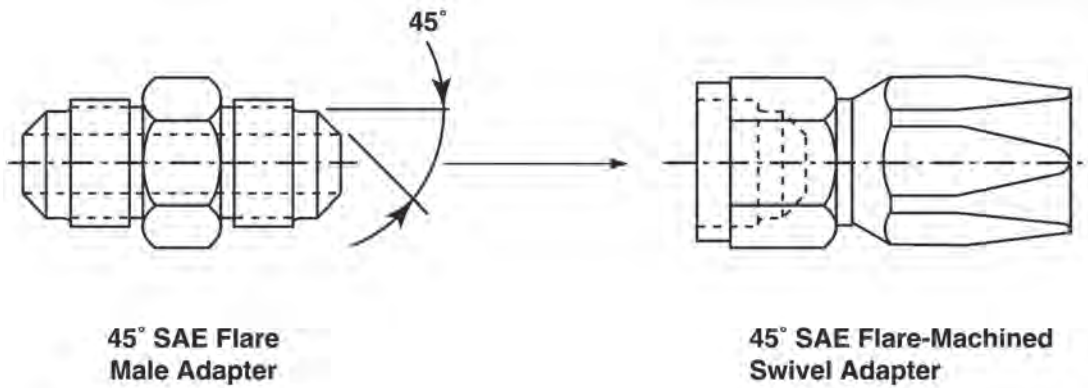

**Table 8. Torque Values for 45° SAE Flare Connections.**

Tube Size	Thread Size	Torque Inch-Pounds	Torque Foot-Pounds
-4	7/16-20	100-110	8-9
-6	5/8-18	215-235	18-20
-8	3/4-16	430-450	36-38
-10	7/8-14	620-650	52-54
-12	1 1/16-12	855-885	71-74



**d. Straight Thread O-ring Boss Connections**

Assembly instructions for Straight Thread O-ring Boss adjustable fittings. (As listed by SAE)

1. Lubricate the O-ring by coating with a light oil or petrolatum and install in the groove adjacent to the face of the metal back-up washer which should be assembled at the extreme end of the groove away from the port. The jamnut should be backed off also.
2. Install the fitting in the port until the metal back-up washer just contacts the face of the port. Do not tighten with a wrench.
3. The fitting may be positioned by turning the fitting out of the port (counterclockwise) up to one full turn. Using two wrenches, tighten the jamnut while holding the adapter body with the other wrench.

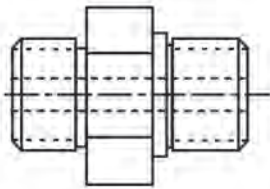
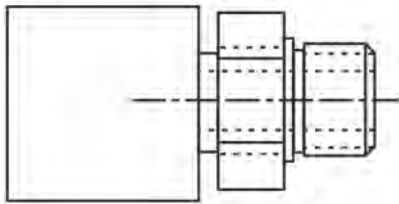
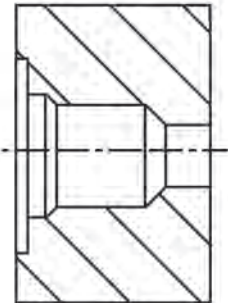
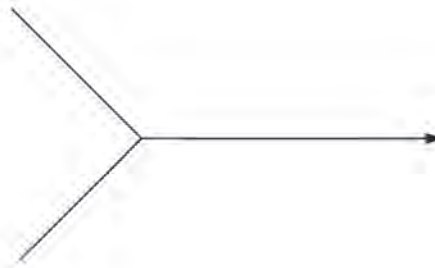
**Male Adjustable Straight Thread****Male Straight Thread****Female Straight Thread  
O-Ring Boss**

## e. Torque Values for Straight Thread O-ring Boss

**Table 9. Low-Pressure Series (SAE J514).**

Tube Size	Thread Size	Torque Inch-Pounds	Torque Foot-Pounds
-4	7/16-20	100-110	8-9
-6	9/16-18	280-290	23-24
-8	3/4-16	480-510	40-42
-10	7/8-14	520-570	43-48
-12	1 1/16-12	820-900	68-75
-16	1 5/16-12	1340-1470	112-123
-20	1 5/8-12	1750-1930	146-161
-24	1 7/8-12	1850-2040	154-170
-32	2 1/2-12	2620-2880	218-240

**Table 10. High-Pressure Series (SAE J1453).**

Tube Size	Thread Size	Torque Inch-Pounds	Torque Foot-Pounds
-4	7/16-20	168-192	14-16
-6	9/16-18	288-312	24-26
-8	3/4-16	600-720	50-60
-10	7/8-14	864-960	72-80
-12	1 1/16-12	1500-1620	125-135
-16	1 5/16-12	2400-2640	200-220
-20	1 5/8-12	2520-3360	210-280
-24	1 7/8-12	3240-4320	270-360

## PIPE THREAD CONNECTION

Because of the design of NPTF Dryseal pipe threads, assembly of the rotation method assures the best resultant connection. The plating does not affect the assembly procedure or the performance of the connection.

The assembly procedure should be performed as follows:

1. Assemble connection hand-tight.
2. Mark - male and female.
3. Rotate male approximately 2 1/2 (3 maximum) full turns past hand-tight position.

### **CAUTION**

**Overtightening will cause deformation of the pipe fitting and damage to the joining fitting, flange, or component. Failure to comply may result in damage to equipment.**

## ASSEMBLY BY THE FLATS METHODS

The assembly by the flats method may be used for 37° flared tube, 37° machined fitting seat, universal radius flare tube and 45° machined seat hose ends and adapters. The flats method is used when torque wrenches are not available or where the application does not permit their use. The following procedure should be used to ensure that the joints have been properly tightened.

1. Tighten nut “hand-tight” until it bottoms out the seat. It should be noted here that “hand-tight” is the point at which the swivel nut will no longer thread onto the adapter when a moderate amount of torque is applied with the hand and fingers. One must also move the fitting lightly side-to-side to eliminate any possible cocking or misalignment to ensure that the nut is completely threaded forward (hand-tight) and not bound-up.
2. To assist in identifying the number of flats tightened, mark a line lengthwise on the nut and extend it onto the adapter. Use an ink pen or marker.

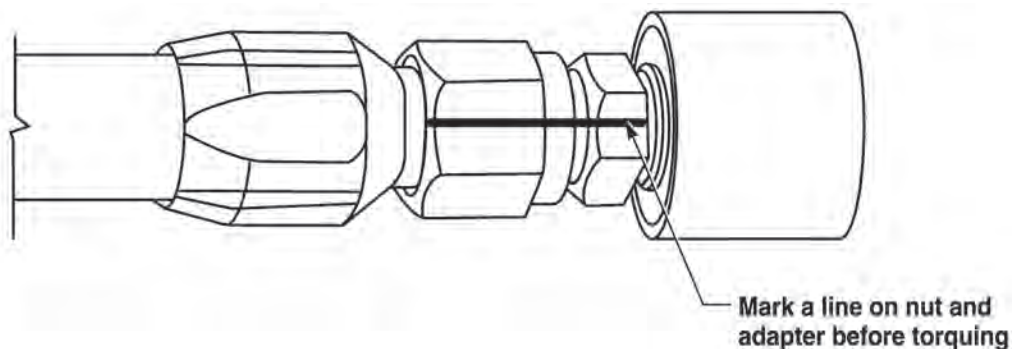

- Using a wrench, rotate the nut to tighten. Turn the nut the amount recommended for the particular fittings. The following chart provides the recommended number of flats rotation for the given connections.

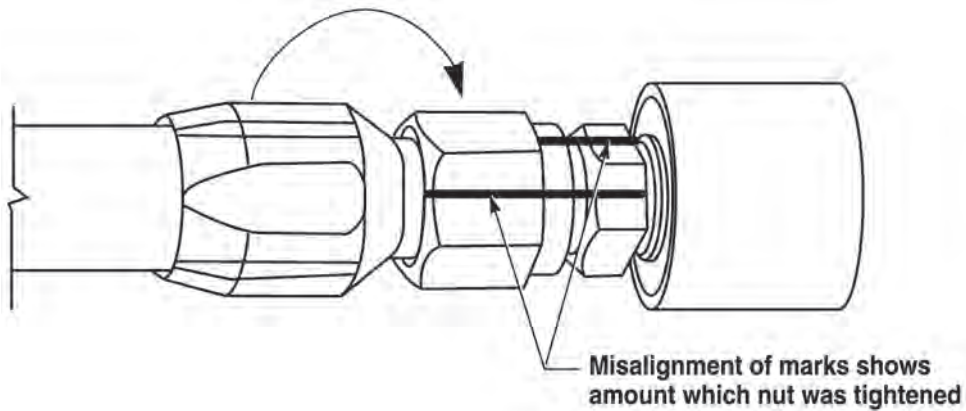

**Table 11. Recommended Flats Rotation.**

Tube Size	37° Flared Tube	45° Machined Fitting Seat	Universal Radius Flare Tube	45° SAE Machined Seat
-4	2 1/4-2 3/4	1 1/2-1 3/4	3-3 1/2	1-1 1/4
-5	3 1/4-3 3/4	1-1 1/2	3-3 1/2	1-1 1/4
-6	2 1/4-2 3/4	1-1 1/2	2 3/4-3	3/4-1
-8	2 1/4-2 3/4	1 1/4-1 3/4	3-3 1/2	1-1 1/4
-10	2-2 1/2	1 1/4-1 3/4	2 1/4-2 3/4	1-1 1/4
-12	2-2 1/2	1-1 1/2	1 1/2-2	1-1 1/4
-16	2 1/4-2 3/4	3/4-1		
-20	1 1/4-1 3/4	1/2-3/4		
-24	3/4-1 1/4	1/2-3/4		
-32	1-1 1/4	3/4		

It should be noted here that these data are guidelines only, and that part condition and application may affect performance.

**NOTE**

It is understandable that circumstances may occur where it is not feasible, due to limited space, to torque fittings. ORS type fittings require very little movement between hand-tightening to make contact with the flush face and additional rotation required for torque retention of the nut. Because of the limited movement required, the use of the flats method for tightening is not feasible. Therefore proper judgment must be used when tightening those fittings.

**BRASS COMPRESSION FITTINGS**

(Reference Parker Air Brakes - AB Fittings and NTA Fittings)

**a. Air Brake Fitting (NTA Fitting)**

Application: Use with SAE J844 A and B nylon tubing air brake systems in cab air controls.

1. Assembly Instructions Method A:

- (a) Be sure tube end is square. Disassemble fitting, fitting body, brass tube support, ferrule, and nut.
- (b) Install nut and ferrule on tube, insert brass tube support.
- (c) Push tube assembly into fitting body until tube bottoms in fitting body, slide nut and ferrule assembly up to engage thread.
- (d) Tighten nut with wrench until one thread remains visible on the fitting body; or, the nut should be screwed down finger-tight, then wrench-tighten the number of additional turns from hand-tight. (Reference Table 12).

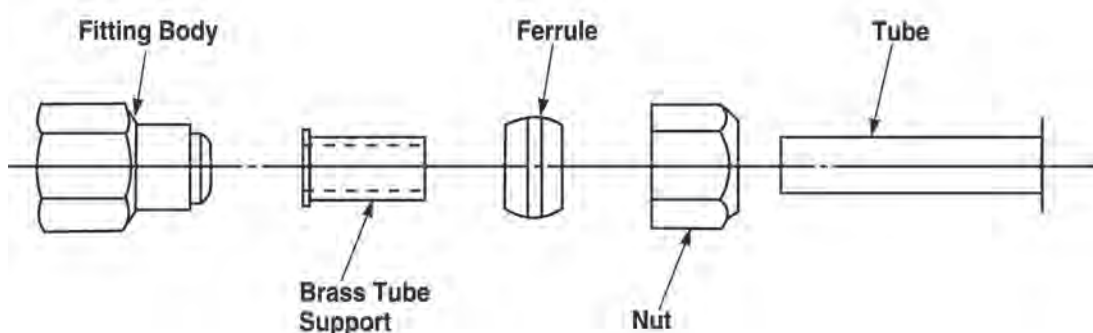

2. Assembly Instructions Method B:

- (a) Be sure tube end is square.
- (b) Loosen nut and insert tube through the nut and ferrule onto the brass tube support.
- (c) Push tube into fitting body until tube bottoms in fitting body.
- (d) Tighten nut with wrench until one thread remains visible on the fitting body; or, the nut should be screwed down finger-tight, then wrench-tighten the number of additional turns from hand-tight. (Reference Table 12).

**Table 12. Air Brake Fitting (NTA Fitting).**

Tube Size	Additional Number of Turns from Hand-Tight
1/4	3
3/8 and 1/2	4
5/8 and 3/4	3 1/2

**b. Air Brake Fitting (AB Fitting)**

Application: Use with copper tubing in air brake system. Bodies, with addition of NTA tube support, are interchangeable with NTA bodies that use SAE J844 nylon tubing. (Ferrules are not inter-changeable).

1. Assembly Instructions:

- (a) Cut tube squarely (or be sure nylon tube end is square). Disassemble fitting, fitting body, and nut.
- (b) Slide nut and ferrule onto tubing.
- (c) Insert tubing assembly into fitting body until tube bottoms on fitting body seat. The nut should be screwed down finger-tight, then wrench tighten the number of additional turns from hand-tight. (Reference Table 13).

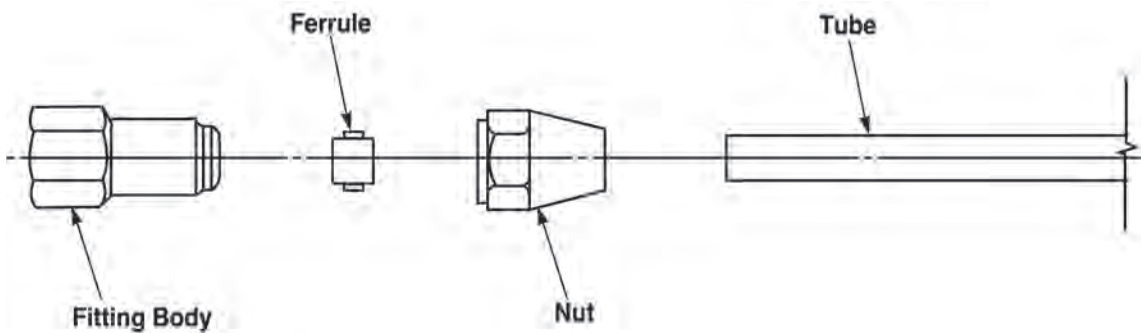

**Table 13. Air Brake Fitting (AB Fitting).**

Tube Size	Additional Number of Turns from Hand-Tight
1/4, 3/8, and 1/2	2
5/8 and 3/4	3

**O-RING INSTALLATION**

When replacing or installing O-rings, do not recklessly push the O-ring over the threads. O-rings could become nicked or torn. A damaged O-ring could lead to leakage problems.

When installing O-rings, the O-rings must be lubricated to prevent scuffing or tearing from occurring.

**END OF WORK PACKAGE**



## **CHAPTER 5**

### **SUPPORTING INFORMATION FOR M1240, M1240A1, AND M1245**



---

## REFERENCES

---

**SCOPE**

This work package lists all pamphlets, field manuals, technical bulletins, and technical manuals referenced in this manual.

**DEPARTMENT OF ARMY PAMPHLETS**

DA PAM 750-8	The Army Maintenance Management System (TAMMS) Users Manual
--------------	---

**FORMS**

DA FORM 2028	Recommended Changes to Publications and Blank Forms
SF 368	Product Quality Deficiency Report

**TECHNICAL BULLETINS**

TB 43-0209	Color, Marking, and Camouflage Painting of Military Vehicles, Construction Equipment, and Material Handling Equipment
TB 750-651	Use of Antifreeze Solutions, Antifreeze Extender Cleaning Compounds and Test Kit in Engine Cooling Systems

**TECHNICAL MANUALS**

TM 9-2355-335-10	Operators Manual for Mine Resistant Ambush Protected All Terrain Vehicle (M-ATV)
TM 9-2355-335-24P	Repair Parts and Special Tools List (RPSTL) Manual Commercial-Off-The-Shelf (COTS) For Mine Resistant Ambush Protected (MRAP) All Terrain Vehicle (M-ATV)
TM 750-244-6	Procedures for Destruction of Tank Automotive Equipment to Prevent Enemy Use (U.S. Army Tank-Automotive Command)

**END OF WORK PACKAGE**



---

## INTRODUCTION FOR STANDARD TWO-LEVEL MAINTENANCE ALLOCATION CHART (MAC)

---

### THE ARMY MAINTENANCE SYSTEM MAC

This introduction provides a general explanation of all maintenance and repair functions authorized at the two maintenance levels under the Two-Level Maintenance System concept.

This MAC (immediately following the introduction) designates overall authority and responsibility for the performance of maintenance functions on the identified end item or component. The application of the maintenance functions to the end item or component shall be consistent with the capacities and capabilities of the designated maintenance levels, which are shown on the MAC in Column (4) as:

Field – includes two subcolumns, Crew (C) and Maintainer (F)

Sustainment – includes two subcolumns, Below Depot (H) and Depot (D)

Maintenance to be performed at field and sustainment levels is described as follows:

1. Crew maintenance. The responsibility of a using organization to perform maintenance on its assigned equipment. It normally consists of inspecting, servicing, lubricating, adjusting, and replacing parts, minor assemblies, and subassemblies. The replace function for this level of maintenance is indicated by the letter "C" in the third position of the SMR code. A "C" appearing in the fourth position of the SMR code indicates complete repair is possible at the crew maintenance level.
2. Maintainer maintenance. Maintenance accomplished on a component, accessory, assembly, subassembly, plug-in unit, or other portion either on the system or after it is removed. The replace function for this level of maintenance is indicated by the letter "F" appearing in the third position of the SMR code. An "F" appearing in the fourth position of the SMR code indicates complete repair is possible at the field maintenance level. Items are returned to the user after maintenance is performed at this level.
3. Below depot sustainment. Maintenance accomplished on a component, accessory, assembly, subassembly, plug-in unit, or other portion either on the system or after it is removed. The replace function for this level of maintenance is indicated by the letter "H" appearing in the third position of the SMR code. An "H" appearing in the fourth position of the SMR code indicates complete repair is possible at the below depot sustainment maintenance level. Items are returned to the supply system after maintenance is performed at this level.
4. Depot sustainment. Maintenance accomplished on a component, accessory, assembly, subassembly, plug-in unit, or other portion either on the system or after it is removed. The replace function for this level of maintenance is indicated by the letter "D" or "K" appearing in the third position of the SMR code. Depot sustainment maintenance can be performed by either depot personnel or contractor personnel. A "D" or "K" appearing in the fourth position of the SMR code indicates complete repair is possible at the depot sustainment maintenance level. Items are returned to the supply systems after maintenance is performed at this level.

The tools and test equipment requirements table (immediately following the MAC) lists the tools and test equipment (both special tools and common tool sets) required for each maintenance function as referenced from the MAC.

The remarks table (immediately following the tools and test equipment requirements) contains supplemental instructions and explanatory notes for a particular maintenance function.

---

## MAINTENANCE FUNCTIONS

Maintenance functions are limited to and defined as follows:

1. **Inspect.** To determine the serviceability of an item by comparing its physical, mechanical, and/or electrical characteristics with established standards through examination (e.g., by sight, sound, or feel). This includes scheduled inspection and gaugings and evaluation of cannon tubes.
2. **Test.** To verify serviceability by measuring the mechanical, pneumatic, hydraulic, or electrical characteristics of an item and comparing those characteristics with prescribed standards on a scheduled basis, i.e., load testing of lift devices and hydrostatic testing of pressure hoses.
3. **Service.** Operations required periodically to keep an item in proper operating condition; e.g., to clean (includes decontamination, when required), to preserve, to drain, to paint, or to replenish fuel, lubricants, chemical fluids, or gases. This includes scheduled exercising and purging of recoil mechanisms. The following are examples of service functions:
  - a. **Unpack.** To remove from packing box for service or when required for the performance of maintenance operations.
  - b. **Repack.** To return item to packing box after service and other maintenance operations.
  - c. **Clean.** To rid the item of contamination.
  - d. **Touch up.** To spot paint scratched or blistered surfaces.
  - e. **Mark.** To restore obliterated identification.
4. **Adjust.** To maintain or regulate, within prescribed limits, by bringing into proper position, or by setting the operating characteristics to specified parameters.
5. **Align.** To adjust specified variable elements of an item to bring about optimum or desired performance.
6. **Calibrate.** To determine and cause corrections to be made or to be adjusted on instruments of test, measuring, and diagnostic equipment used in precision measurement. Consists of comparisons of two instruments, one of which is a certified standard of known accuracy, to detect and adjust any discrepancy in the accuracy of the instrument being compared.
7. **Remove/Install.** To remove and install the same item when required to perform service or other maintenance functions. Install may be the act of emplacing, seating, or fixing into position a spare, repair part, or module (component or assembly) in a manner to allow the proper functioning of an equipment or system.
8. **Paint (ammunition only).** To prepare and spray color coats of paint so that the ammunition can be identified and protected. The color indicating primary use is applied, preferably, to the entire exterior surface as the background color of the item. Other markings are to be repainted as original so as to retain proper ammunition identification.
9. **Replace.** To remove an unserviceable item and install a serviceable counterpart in its place. "Replace" is authorized by the MAC and assigned maintenance level is shown as the third position code of the Source, Maintenance and Recoverability (SMR) code.
10. **Repair.** The application of maintenance services, including fault location/troubleshooting, removal/installation, disassembly/assembly procedures and maintenance actions to identify troubles and restore serviceability to an item by correcting specific damage, fault, malfunction, or failure in a part, subassembly, module (component or assembly), end item, or system.



---

## NOTE

The following definitions are applicable to the “repair” maintenance function:

- Services. Inspect, test, service, adjust, align, calibrate, and/or replace.
  - Fault location/troubleshooting. The process of investigating and detecting the cause of equipment malfunctioning; the act of isolating a fault within a system or Unit Under Test (UUT).
  - Disassembly/assembly. The step-by-step breakdown (taking apart) of a spare/functional group coded item to the level of its least component, that is assigned an SMR code for the level of maintenance under consideration (i.e., identified as maintenance significant).
  - Actions. Welding, grinding, riveting, straightening, facing, machining, and/or resurfacing.
11. Overhaul. That maintenance effort (service/action) prescribed to restore an item to a completely serviceable/operational condition as required by maintenance standards in appropriate technical publications. Overhaul is normally the highest degree of maintenance performed by the Army. Overhaul does not normally return an item to like new condition.
12. Rebuild. Consists of those services/actions necessary for the restoration of unserviceable equipment to a like new condition in accordance with original manufacturing standards. Rebuild is the highest degree of material maintenance applied to Army equipment. The rebuild operation includes the act of returning to zero those age measurements (e.g., hours/miles) considered in classifying Army equipment/ components.

### EXPLANATION OF COLUMNS IN THE MAC

Column (1) Group Number. Column (1) lists Functional Group Code (FGC) numbers, the purpose of which is to identify maintenance significant components, assemblies, subassemblies, and modules with the Next Higher Assembly (NHA).

Column (2) Component/Assembly. Column (2) contains the item names of components, assemblies, subassemblies, and modules for which maintenance is authorized.

Column (3) Maintenance Function. Column (3) lists the functions to be performed on the item listed in column (2). (For a detailed explanation of these functions refer to “Maintenance Functions” outlined above).

Column (4) Maintenance Level. Column (4) specifies each level of maintenance authorized to perform each function listed in column (3), by indicating work time required (expressed as manhours in whole hours or decimals) in the appropriate subcolumn. This work time figure represents the active time required to perform that maintenance function at the indicated level of maintenance. If the number or complexity of the tasks within the listed maintenance function varies at different maintenance levels, appropriate work time figures are to be shown for each level. The work time figure represents the average time required to restore an item (assembly, subassembly, component, module, end item, or system) to a serviceable condition under typical field operating conditions. This time includes preparation time (including any necessary disassembly/assembly time), troubleshooting/fault location time, and quality assurance time in addition to the time required to perform the specific tasks identified for the maintenance functions authorized in the MAC.

---

The symbol designations for the various maintenance levels are as follows:

Field:

C Crew maintenance

F Maintainer Maintenance

Sustainment:

H Below depot maintenance

D Depot maintenance

### NOTE

The "L" maintenance level is not included in column (4) of the MAC. Functions to this level of maintenance are identified by work time figure in the "H" column of column (4), and an associated reference code is used in the REMARKS column (6). This code is keyed to the remarks and the SRA complete repair application is explained there.

Column (5) Tools and Equipment Reference Code. Column (5) specifies, by code, those common tool sets (not individual tools), common Test, Measurement and Diagnostic Equipment (TMDE), and special tools, special TMDE and special support equipment required to perform the designated function. Codes are keyed to the entries in the tools and test equipment table.

Column (6) Remarks Code. When applicable, this column contains a letter code, in alphabetical order, which is keyed to the remarks table entries.

### EXPLANATION OF COLUMNS IN THE TOOLS AND TEST EQUIPMENT REQUIREMENTS

Column (1) - Tool or Test Equipment Reference Code. The tool or test equipment reference code correlates with a code used in column (5) of the MAC.

Column (2) - Maintenance Level. The lowest level of maintenance authorized to use the tool or test equipment.

Column (3) - Nomenclature. Name or identification of the tool or test equipment.

Column (4) - National Stock Number (NSN). The NSN of the tool or test equipment.

Column (5) - Tool Number. The manufacturer's part number.

### EXPLANATION OF COLUMNS IN THE REMARKS

Column (1) - Remarks Code. The code recorded in column (6) of the MAC.

Column (2) - Remarks. This column lists information pertinent to the maintenance function being performed as indicated in the MAC.

**END OF TASK**

**END OF WORK PACKAGE**

**MAINTENANCE ALLOCATION CHART (MAC)**

*Table 1. Maintenance Allocation Chart (MAC) for M-ATV.*

(1)  GROUP NUMBER	(2)  COMPONENT/ ASSEMBLY	(3)  MAINTENANCE FUNCTION	(4) MAINTENANCE LEVEL				(5)  TOOLS AND EQUIPMENT REFERENCE CODE	(6)  REMARKS CODE
			FIELD		SUSTAINMENT			
			CREW	MAINTAINER	BELOW DEPOT	DEPOT		
			C	F	H	D		
01	ENGINE							
0100	Engine Assembly	Service		4.0			19, 44, 53	
		Replace		40.0			8, 9, 19, 26, 33, 39,44, 46	
0102	Crankshaft Rear Oil Seal	Replace		42.0			6, 19, 25, 27, 44	
0103	Flexplate	Replace		42.0			44, 53	
0106	Engine Oil Filter	Replace		1.0			19, 44, 46	
03	Fuel System							
0302	Prime Fuel System	Service	0.5					
0304-01	Air Cleaner Assembly (M1240/M1245)	Replace		2.0			44	
0304-02	Air Cleaner Assembly (M1240A1)	Replace		2.5			44	
0304-03	Air Filter	Replace		.5			44	
0304-04	Air Intake Hoses (M1240/ M1245)	Replace		3.0			44, 46	
0305	Turbocharger Assembly	Replace		6.0			44	
0306-01	Fuel Lines	Replace		10.0			19, 44	
0306-02	Fuel Tank	Replace		12.0			20, 44	
0309-01	Fuel Filter	Replace		.5			44, 46	
0309-02	Fuel/Water Separator Base	Replace		.5			44	
0309-03	Fuel/Water Separator Filter	Replace		1.0			44, 46	
04	Exhaust System							
0401-01	Exhaust Pipe (M1240/M1245)	Replace		4.0			44	
0401-02	Exhaust Pipe (M1240A1)	Replace		4.0			44	

**Table 1. Maintenance Allocation Chart (MAC) for M-ATV.**

(1)  GROUP NUMBER	(2)  COMPONENT/ ASSEMBLY	(3)  MAINTENANCE FUNCTION	(4) MAINTENANCE LEVEL				(5)  TOOLS AND EQUIPMENT REFERENCE CODE	(6)  REMARKS CODE
			FIELD		SUSTAINMENT			
			CREW	MAINTAINER	BELOW DEPOT	DEPOT		
			C	F	H	D		
0401-03	Muffler (M1240/M1245)	Replace		6.0			44	
0401-04	Muffler (M1240A1)	Replace		6.0			19, 44	
05	Cooling System							
0501-01	Charge Air Cooler	Replace		10			44	
0501-02	Coolant Reservoir	Replace		1.0			19, 44	
0501-03	Cooling System (Reservoir Equipped)	Service		2.0			19, 44	
0501-04	Cooling System (Surge Tank Equipped)	Service		2.0			19, 44	
0501-05	Cooling System Assembly and Supports	Replace		14.0			19, 44, 63	
0501-06	Radiator and Transmission Oil Cooler	Replace		8.0			19, 44	
0501-07	Surge Tank	Replace		2.0			19, 44	
0502-01	Cooling Shroud	Replace		6.0			19, 44	
0502-02	Radiator Baffle	Replace		4.0			19, 44, 46	
0503	Thermostat	Replace		3.0			44	
0504-01	Water Pump Belt	Adjust		6.0			21, 44	
		Replace		7.0			44	
0505-01	Fan and Fan Shroud	Replace		5.0			44, 53, 55	
0505-02	Fan Clutch	Replace		7.0			44	
06	Electrical System							
0601-01	Alternator Drive Belt	Replace		7.5			44	
0601-02	Alternator	Replace		7.0			44, 51	
0602	Voltage Regulator	Replace		1.0			44	
0603	Starter	Replace		10.0			19, 44	

**Table 1. Maintenance Allocation Chart (MAC) for M-ATV.**

(1)  GROUP NUMBER	(2)  COMPONENT/ ASSEMBLY	(3)  MAINTENANCE FUNCTION	(4) MAINTENANCE LEVEL				(5)  TOOLS AND EQUIPMENT REFERENCE CODE	(6)  REMARKS CODE
			FIELD		SUSTAINMENT			
			CREW	MAINTAINER	BELOW DEPOT	DEPOT		
			C	F	H	D		
0605	Ignition Relay	Replace		2.0			44	
0606	Reset Circuit Breaker	Service	0.5					
0607-01	Circuit Breaker, Auxiliary	Replace		1.0			44	
0607-02	Circuit Breaker, Dash	Replace		1.0			44	
0607-03	Dash Control, HVAC	Replace		1.0			44	
0607-04	Deicer Circuit Breaker	Replace		1.5			44	
0608-01	Battery Disconnect Switch	Replace		2.0			44, 50	
0608-02	Engine Electronic Control Module (ECM)	Replace		6.0			44	
0608-03	NATO Slave Receptacle	Replace		2.0			44	
0608-04	Vehicle Interface Module (VIM)	Replace		4.0			44	
0609-01	Blackout Drivelight	Replace		1.0			44	
0609-02	Check-6 Rear Composite Light	Replace		1.0			44	
0609-03	Clearance Lights	Replace		1.0			44	
0609-04	Front Composite Light	Replace		1.0			44	
0609-05	Headlight	Replace		1.0			44	
0609-06	Infrared (IR) Light (M1245)	Replace		2.5			44	
0609-07	Rear Composite Light	Replace		1.0			44	
0609-08	Reverse Light	Replace		1.0			44	
0609-09	Spotlight	Replace		1.0			44	
0609-10	Spotlight Controller (Front)	Replace		2.0			44	

**Table 1. Maintenance Allocation Chart (MAC) for M-ATV.**

(1)  GROUP NUMBER	(2)  COMPONENT/ ASSEMBLY	(3)  MAINTENANCE FUNCTION	(4) MAINTENANCE LEVEL				(5)  TOOLS AND EQUIPMENT REFERENCE CODE	(6)  REMARKS CODE
			FIELD		SUSTAINMENT			
			CREW	MAINTAINER	BELOW DEPOT	DEPOT		
			C	F	H	D		
0609-11	Spotlight Controller (Rear)	Replace		2.0			44	
0612-01	Battery (M1240/ M1240A1)	Replace		1.0			19, 44, 46, 55	
0612-02	Battery (M1245)	Replace		1.0			19, 44, 46, 55	
0612-03	Battery Cover	Replace	0.5	0.5			44	
0612-04	Battery Isolator	Replace		1.0			44, 55	
0612-05	Battery PDU Box (M1245)	Replace		3.0			44	
0612-06	PDU Deck Box (M1245)	Replace		2.0			44, 46	
0613-01	12-Volt Power Converter (Driver Side)	Replace		1.0			44	
0613-02	12-Volt Power Converter (Passenger Side)			1.0			44	
0613-03	Dimmer	Replace		1.0			44	
0613-04	Flasher	Replace		1.0			44	
0613-05	Transmission Control Module (TCM)	Replace		2.5			44	
0613-06	Wiring Harness	Repair		1.0			11, 12, 17, 19, 31, 44, 59, 60, 61	
0615 07	EMI Filter Transmission	Replace		1.0			44	
0700-01	Transmission (M1240/M1245)	Service		8.0			19, 44, 53	
		Replace		40.0			8, 9, 19, 26, 33, 39, 44, 46	
0700-02	Transmission (M1240A1)	Service		16.0			19, 44, 53	
0700-03	Transmission Spring Support and Bracket (M1240/M1245)	Replace		6.0			44, 46	



**Table 1. Maintenance Allocation Chart (MAC) for M-ATV.**

(1)  GROUP NUMBER	(2)  COMPONENT/ ASSEMBLY	(3)  MAINTENANCE FUNCTION	(4) MAINTENANCE LEVEL				(5)  TOOLS AND EQUIPMENT REFERENCE CODE	(6)  REMARKS CODE
			FIELD		SUSTAINMENT			
			CREW	MAINTAINER	BELOW DEPOT	DEPOT		
			C	F	H	D		
0700-04	Transmission Spring Support and Bracket (M1240A1)	Replace		12.0			44, 46	
0721-01	Transmission Breather (M1240/M1245)	Replace		5.0			44	
0721-02	Transmission Breather (M1240A1)	Replace		10.0			44	
0721-03	Transmission Cooler (M1240/M1245)	Replace		16.0			19, 44	
0721-04	Transmission Cooler (M1240A1)	Replace		20.0			19, 44	
0721-05	Transmission Filter (M1240/M1245)	Replace		9.0			19, 44	
0721-06	Transmission Filter (M1240A1)	Replace		18.0			19, 44	
08	Transfer and Final Drive							
0801-01	Transfer Case Assembly	Replace		25.0			42, 44, 46, 51	
		Service		0.7			19, 44, 49	
0801-02	Transfer Case Shift Stop Switch	Replace		13.0			19, 22, 44	
09	Propeller Shafts							
0900	Propeller Shafts	Replace		15.0			44, 51, 53, 64	
10	Front Axle							
1000-01	Axle Differential	Service		1.0			19, 44	
1000-02	Inner Shaft	Replace		5.0			19, 44, 51	
1002-01	Differential Housing and Differential	Replace		25.0			19, 44, 46	
1002-02	Differential Lock	Replace		2.0			44	
1002-03	Differential Yoke and Seal	Replace		5.0			1, 19, 44	

**Table 1. Maintenance Allocation Chart (MAC) for M-ATV.**

(1)  GROUP NUMBER	(2)  COMPONENT/ ASSEMBLY	(3)  MAINTENANCE FUNCTION	(4) MAINTENANCE LEVEL				(5)  TOOLS AND EQUIPMENT REFERENCE CODE	(6)  REMARKS CODE
			FIELD		SUSTAINMENT			
			CREW	MAINTAINER	BELOW DEPOT	DEPOT		
			C	F	H	D		
1004-01	Control Arm Ball Joint	Replace		10.0			7, 10, 44, 52	
1004-02	Halfshaft and Seal	Replace		3.0			14, 19, 44, 46, 51, 53	
1004-03	Jounce Bumper	Replace		1.0			19, 44, 51	
1004-04	Knuckle	Replace		10.0			1, 44, 52	
1004-05	Rebound Bumper	Replace		1.5			19, 44, 51	
1004-06	Upper and Lower Control Arm	Replace		8.0			14, 19, 44	
11	Rear Axle							
1100-01	Axle Differential	Service		1.0			19, 44	
1100-02	Inner Shaft	Replace		5.0			19, 44, 51	
1102-01	Differential Housing and Differential	Replace		20.0			19, 44, 46	
1102-02	Differential Lock	Replace		2.0			44	
1102-03	Differential Yoke and Seal	Replace		2.0			1, 19, 44, 55, 56, 57, 58	
1104-01	Control Arm Ball Joint	Replace		10.0			7, 10, 44, 52	
1104-02	Halfshaft and Seal	Replace		3.0			14, 19, 44, 46, 51, 53	
1104-03	Jounce Bumper	Replace		1.0			19, 44, 51	
1104-04	Knuckle	Replace		10.0			1, 44, 52	
1104-05	Rebound Bumper	Replace		1.5			19, 44, 51	
1104-06	Upper and Lower Control Arm	Replace		8.0			14, 19, 44	
12	Brakes	Inspect		2.0			44, 63	
		Adjust		2.5			44, 63	
1202-01	Anti-Lock Brake System (ABS) Electronic Control Unit (ECU)	Replace		13.0			44	
1202-02	Brake Drum	Replace		2.0			44, 63	
1202-03	Brake Shoe	Replace		1.0			44, 47	

**Table 1. Maintenance Allocation Chart (MAC) for M-ATV.**

(1)  GROUP NUMBER	(2)  COMPONENT/ ASSEMBLY	(3)  MAINTENANCE FUNCTION	(4) MAINTENANCE LEVEL				(5)  TOOLS AND EQUIPMENT REFERENCE CODE	(6)  REMARKS CODE
			FIELD		SUSTAINMENT			
			CREW	MAINTAINER	BELOW DEPOT	DEPOT		
			C	F	H	D		
1204-04	Spider/Spindle	Replace		8.0			14, 19, 44, 51	
1208-01	Air Dryer	Replace		14.0			44	
1208-02	Air Dryer Filter	Replace		1.0			44	
1208-03	Air Pressure Alarm	Replace		1.0			44	
1208-04	Air Reservoir Check Valve	Replace		8.0			44, 46	
1208-05	Air Reservoir (Primary) (Four Tank System)	Replace		8.0			19, 44	
1208-06	Air Reservoir (Secondary) (Four Tank System)	Replace		8.0			44	
1208-07	Air Reservoir (Secondary) (Two Tank System)	Replace		12.0			19, 44	
1208-08	Air Reservoir (Supply No. 1) (Four Tank System)	Replace		9.0			44	
1208-09	Air Reservoir (Supply No. 2) (Four Tank System)	Replace		10.0			44	
1208-10	Air Reservoir (Supply/ Primary) (Two Tank System)	Replace		18.0			19, 44	
1208-11	Air Solenoid Manifolds	Replace		2.0			44	
1208-12	Anti-Lock Brake System (ABS) Valve (Axle No. 1)	Replace		6.0			44	
1208-13	Anti-Lock Brake System (ABS) Valve (Axle No. 2)	Replace		4.0			44	

**Table 1. Maintenance Allocation Chart (MAC) for M-ATV.**

(1)  GROUP NUMBER	(2)  COMPONENT/ ASSEMBLY	(3)  MAINTENANCE FUNCTION	(4) MAINTENANCE LEVEL				(5)  TOOLS AND EQUIPMENT REFERENCE CODE	(6)  REMARKS CODE
			FIELD		SUSTAINMENT			
			CREW	MAINTAINER	BELOW DEPOT	DEPOT		
			C	F	H	D		
1208-14	Automatic Traction Control (ATC) Valve Double Check Valve	Replace		.7			44	
1208-15	Automatic Traction Control (ATC) Valve	Replace		1.5			44	
1208-16	Brake Chamber (Axle No. 1)	Replace		2.0			44	
1208-17	Brake Chamber (Axle No. 2)	Replace		2.0			44	
1208-18	Parking Brake Stoplight Switch	Replace		1.0			44	
1208-19	Pressure Protection Valve (Emergency Supply)	Replace		16.0			44	
1208-20	Pressure Protection Valve (Secondary Air Reservoir)	Replace		16.0			44	
1208-21	Pressure Switch	Replace		1.0			44	
1208-22	Quick Release Valve (Axle No. 1)	Replace		18.0			44, 51	
1208-23	Quick Release Valve (Axle No. 2)	Replace		1.0			44	
1208-24	Rear Glad Hands Quick Release Valve	Replace		2.5			44	
1208-25	Safety (Relief) Valve	Replace		1.0			44	
1208-26	Service Brake Relay Double Check Valve	Replace		3.0			44	
1208-27	Service Brake Relay Valve	Replace		3.0			44	
1208-28	Spring Brake Double Check Valve	Replace		.7			44	

**Table 1. Maintenance Allocation Chart (MAC) for M-ATV.**

(1)  GROUP NUMBER	(2)  COMPONENT/ ASSEMBLY	(3)  MAINTENANCE FUNCTION	(4) MAINTENANCE LEVEL				(5)  TOOLS AND EQUIPMENT REFERENCE CODE	(6)  REMARKS CODE
			FIELD		SUSTAINMENT			
			CREW	MAINTAINER	BELOW DEPOT	DEPOT		
			C	F	H	D		
1208-29	Spring Brake Relay Valve	Replace		3.0			44	
1208-30	Spring Brake Valve	Replace		11.0			44	
1208-31	Stoplight Switch	Replace		1.0			44	
1208-32	Tractor Protection Valve	Replace		2.0			44	
1208-33	Drain Air System	Service	0.5					
1208-34	Air System	Test		0.5			5, 44, 66	
1209-01	Air Compressor	Replace		9.0			44	
1209-02	Air Governor	Adjust		0.5			44	
		Replace		1.0			44	
13	Wheels and Tracks							
1311-01	Hub	Repair		18.0			15, 44	
		Replace		16.0			38, 44, 48, 51	
1311-02	Wheel End	Replace		5.0			19, 44, 49	
		Service		1.0			19, 44	
1311-03	Wheel/Tire Assembly	Replace		1.0				
		Service		4.0				
1311-04	Spare Tire Unstow/Stow (For 395/85R20 Spare Tire Carrier)			0.5			19, 44	
1311-05	Spare Tire Unstow/Stow (For Upgraded Spare Tire Carrier)			0.5			19, 44	
1311-06	Spare Tire Unstow/Stow (M1245)			0.5			19, 44	
1313-01	Tire Inflate/ Deflate	Service	0.5					
1313-02	Snow Chains	Replace	1.0					
14	Steering							
1401-01	Pitman Arm	Replace		2.0			19, 44, 52	

**Table 1. Maintenance Allocation Chart (MAC) for M-ATV.**

(1)  GROUP NUMBER	(2)  COMPONENT/ ASSEMBLY	(3)  MAINTENANCE FUNCTION	(4) MAINTENANCE LEVEL				(5)  TOOLS AND EQUIPMENT REFERENCE CODE	(6)  REMARKS CODE
			FIELD		SUSTAINMENT			
			CREW	MAINTAINER	BELOW DEPOT	DEPOT		
			C	F	H	D		
1401-02	Steering Arm	Replace		10.0			19, 44, 52	
1401-03	Steering Column and Bracket	Replace		6.0			44	
1401-04	Steering Wheel	Replace		2.0			19, 44, 53	
1401-05	Tie Rod	Replace		12.0			19, 44, 51	
1401-06	Toe Control Link (Axle No. 1)	Replace		2.0			19, 44, 51	
1401-07	Toe Control Link (Axle No. 2)	Replace		2.0			19, 44, 51	
1401-08	Upper Steering Shaft	Replace		2.0			44, 49	
1404-01	Lower Steering Shaft	Replace		5.0			44	
1404-02	Middle Steering Shaft	Replace		16.0			44	
1407-01	Primary Steering Gear	Replace		30.0			19, 44	
1407-02	Secondary Steering Gear	Replace		30.0			19, 44	
1407-03	Steering Gear Mitre	Replace		6.0			44, 53	
1407-04	Steering Gear Relief	Adjust		2.0			44	
1407-05	Steering Gear Tray	Replace		26.0			19, 44	
1410	Power Steering Pump	Replace		4.0			19, 44	
1413-01	Power Steering Filter	Replace		2.0			44	
1413-02	Power Steering Reservoir and Bracket	Replace		7.0			19, 44	
		Service		11.0			19, 44	
15	Frame, Towing Attachments, and Drawbars							
1501-01	Front Bumper (Standard SPARK)	Replace		15.0			19, 44	



**Table 1. Maintenance Allocation Chart (MAC) for M-ATV.**

(1)  GROUP NUMBER	(2)  COMPONENT/ ASSEMBLY	(3)  MAINTENANCE FUNCTION	(4) MAINTENANCE LEVEL				(5)  TOOLS AND EQUIPMENT REFERENCE CODE	(6)  REMARKS CODE
			FIELD		SUSTAINMENT			
			CREW	MAINTAINER	BELOW DEPOT	DEPOT		
			C	F	H	D		
1501-02	Front Bumper (Updated SPARK)	Replace		15.0			19, 44	
1501-03	Push Bumper (M1245)	Replace		2.0			19, 41, 44, 52	
1501-04	Rear Crossmember (M1240/ M1240A1)	Replace		13.0			44	
1501-05	Skid Plate	Replace		4.0			44, 46, 52	
1501-06	Spark Bar and Strut (Updated SPARK)	Replace		4.0			19, 44	
1504-01	Tire Carrier (M1245)	Replace		4.0			44	
1504-02	Tire Carrier (For 395/85R20 Spare Tire Carrier)	Replace		2.0			19, 44	
1504-03	Tire Carrier (For Upgraded Spare Tire Carrier)	Replace		3.0			19, 44	
16	Springs and Shock Absorbers							
1601	Coil Spring and Seat	Replace		4.0			13, 19, 44	
1604-01	Shock Absorber (M1240/M1245)	Replace		1.0			4, 19, 44, 51	
1604-02	Shock Absorber (M1240A1)	Replace		1.5			2, 3, 6, 7, 12, 23, 30, 44	
18	Body, Cab, Hood, and Hull							
1801-01	Antenna Platform (M1240/ M1240A1)	Replace		3.0			18, 44, 63	
1801-02	B-Pillar Handle	Replace		.5			44	
1801-03	Belly Deflector Crossmember Weldment	Replace		16.0			44	

**Table 1. Maintenance Allocation Chart (MAC) for M-ATV.**

(1)  GROUP NUMBER	(2)  COMPONENT/ ASSEMBLY	(3)  MAINTENANCE FUNCTION	(4) MAINTENANCE LEVEL				(5)  TOOLS AND EQUIPMENT REFERENCE CODE	(6)  REMARKS CODE
			FIELD		SUSTAINMENT			
			CREW	MAINTAINER	BELOW DEPOT	DEPOT		
			C	F	H	D		
1801-04	Capsule Armor	Replace		4.5			44	
1801-05	Capsule Door	Replace		3.0			40, 44	
1801-06	Capsule Step (M1240/M1245)	Replace		1.0			44	
1801-07	Capsule Step (M1240A1)	Replace		2.0			18, 44, 46	
1801-08	Center Belly Deflector Panel (M1240/M1245)	Replace		4.0			44, 46	
1801-09	Coupler Box (M1240/ M1240A1)	Replace		.5			44	
1801-10	Crew Vehicle Receiver/ Jammer (CVRJ) Box (M1240/ M1240A1)	Replace		1.0			44	
1801-11	Dash Panel, Air System	Replace		1.0			44	
1801-12	Dash Panel, CTIS	Replace		1.0			44	
1801-13	Dash Panel, Instrument Panel	Replace		3.0			19, 44, 62	
1801-14	Dash Panel, Transmission	Replace		1.0			44	
1801-15	Dash	Replace		8.0			44	
1801-16	Driver Side Belly Deflector Panel (M1240/ M1245)	Replace		8.0			44, 46	
1801-17	Driver Side Splash Guard (AFES Nitrogen Detection)	Replace		2.0			44	
1801-18	Driver Side Splash Guard (AFES Linear Wire Detection)	Replace		2.5			44	
1801-19	Engine Belly Deflector Panel	Replace		10.0			44, 46	

**Table 1. Maintenance Allocation Chart (MAC) for M-ATV.**

(1)  GROUP NUMBER	(2)  COMPONENT/ ASSEMBLY	(3)  MAINTENANCE FUNCTION	(4) MAINTENANCE LEVEL				(5)  TOOLS AND EQUIPMENT REFERENCE CODE	(6)  REMARKS CODE
			FIELD		SUSTAINMENT			
			CREW	MAINTAINER	BELOW DEPOT	DEPOT		
			C	F	H	D		
1801-20	Front Wheel Well Deflector Panel (M1240A1)	Replace		4.0			19, 44, 46	
1801-21	Hood (AFES Nitrogen Detection)	Replace		14.0			36, 41, 44, 46	
1801-22	Hood (AFES Linear Wire Detection)	Replace		16.0			44, 54, 63	
1801-23	Hood and Grill (M1245)	Replace		16.0			44, 46, 49	
1801-24	Hood Latch	Replace		1.0			44	
1801-25	Litter Door Dyneema Panel (M1245)	Replace		3.0			44	
1801-26	Passenger Side Belly Deflector Panel (M1240/M1245)	Replace		8.0			44, 45	
1801-27	Passenger Side Engine Panel (M1240/M1245)	Replace		1.0			44	
1801-28	Passenger Side Splash Guard (AFES Nitrogen Detection)	Replace		2.0			44	
1801-29	Passenger Side Splash Guard (AFES Linear Wire Detector)	Replace		2.0			44	
1801-30	Rear Capsule Doors (M1245)	Replace		6.0			44	
1801-31	Rear Cargo Door Dyneema Panel (M1245)	Replace		3.0			44	
1801-32	Rear Wall Dyneema Panel (M1245)	Replace		3.0			44	

**Table 1. Maintenance Allocation Chart (MAC) for M-ATV.**

(1)  GROUP NUMBER	(2)  COMPONENT/ ASSEMBLY	(3)  MAINTENANCE FUNCTION	(4) MAINTENANCE LEVEL				(5)  TOOLS AND EQUIPMENT REFERENCE CODE	(6)  REMARKS CODE
			FIELD		SUSTAINMENT			
			CREW	MAINTAINER	BELOW DEPOT	DEPOT		
			C	F	H	D		
1801-33	Rear Wheel Well Deflector Panel, Driver Side (M1240A1)	Replace		6.0			19, 44, 46	
1801-34	Rear Wheel Well Deflector Panel, Passenger Side (M1240A1)	Replace		8.0			19, 44, 46	
1801-35	Side Wall Dyneema Panel (M1245)	Replace		3.0			44	
1801-36	Spotlight Bracket	Replace		1.0			44	
1801-37	Underbody Improvement and Belly Deflector Armor Panels (M1240A1)	Replace		12.0			2, 19, 35, 44, 46, 52, 53, 65	
1801-38	Wheel Well Deflector Panel (M1240/M1245)	Replace		2.0			19, 44	
1802-01	Capsule Window	Replace		2.0			37, 44, 49	
1802-02	Capsule Windshield (M1240/M1240A1)	Replace		10.0			18, 44	
1802-03	Front Mud Flap (Mud Protection)	Replace		1.0			44	
1802-04	Rear Fender Extension (Mud Protection)	Replace		1.0			44	
1806-01	5th Seat (M1245)	Replace		2.0			44	
1806-02	Floor Mat Replacement	Replace		.5			44	
1806-03	Gunner Platform	Adjust		.5			44	

**Table 1. Maintenance Allocation Chart (MAC) for M-ATV.**

(1)  GROUP NUMBER	(2)  COMPONENT/ ASSEMBLY	(3)  MAINTENANCE FUNCTION	(4) MAINTENANCE LEVEL				(5)  TOOLS AND EQUIPMENT REFERENCE CODE	(6)  REMARKS CODE
			FIELD		SUSTAINMENT			
			CREW	MAINTAINER	BELOW DEPOT	DEPOT		
			C	F	H	D		
1806-04	Gunner Platform Mat (M1240A1)	Replace		1.0			44	
1806-05	Seat (M1240/M1245)	Replace		2.0			44	
1806-06	Seat, Front (M1240A1)	Replace		2.0			19, 44, 46, 51, 53	
1806-07	Seat, Rear (M1240A1)	Replace		8.0			19, 44, 46, 51, 53	
1806-08	Seatbelt, Driver (M1240/M1245)	Replace		2.0			44, 53	
1806-09	Seatbelt (M1240A1)	Replace		2.0			19, 44, 53	
1806-10	Seatbelt, Passenger (M1240/M1245)	Replace		1.5			44, 53	
1810-01	Cargo Deck Litter Door (M1245)	Replace		2.0			44	
1810-02	Cargo Deck Litter Door Frame (M1245)	Replace		4.0			44	
1810-03	Cargo Deck Rear Door (M1245)	Replace		3.0			44	
1810-04	Cargo Deck Rear Wall (M1245)	Replace		6.0			44	
1810-06	Cargo Deck (M1240/M1240A1)	Replace		20.0			19, 44, 46, 55, 63	
1810-07	Cargo Deck (M1245)	Replace		18.0			38, 44, 49	
1810-08	Cargo Deck Side Wall (M1245)	Replace		9.0			44	
1810-09	GFE Cabinet (M1245)	Replace		3.0			44	
1810-10	Quick Lock Floor (M1245)	Replace		4.0			44	

**Table 1. Maintenance Allocation Chart (MAC) for M-ATV.**

(1)  GROUP NUMBER	(2)  COMPONENT/ ASSEMBLY	(3)  MAINTENANCE FUNCTION	(4) MAINTENANCE LEVEL				(5)  TOOLS AND EQUIPMENT REFERENCE CODE	(6)  REMARKS CODE
			FIELD		SUSTAINMENT			
			CREW	MAINTAINER	BELOW DEPOT	DEPOT		
			C	F	H	D		
19	Turret					44		
1901	Gunner Harness Retractor	Replace		2.0		44		
1905	Mk-44 Receptacle (M1245)	Replace		1.0		44		
20	Winch							
2001-01	Winch Cable Guide and Guard	Replace		1.5		44		
2001-02	Winch Cable	Replace		1.0		44		
2001-03	Winch (Standard SPARK)	Replace		3.0		19, 44		
2001-04	Winch/Front Crossmember (Updated SPARK)	Replace		4.5		19,36, 44, 51, 63		
2001-05	Winch Cable (Updated SPARK)	Replace		1.0		5, 16, 19, 44, 46, 55		
22	Auxiliary Items							
2202-01	Auxiliary Mirror	Replace		1.0		19, 44, 55		
2202-02	Check-6 Control Boxes	Replace		1.0		44		
2202-03	Lower Plenum	Replace		1.0		44		
2202-04	Mirror	Replace		.5		44		
2202-05	Windshield Wiper Arm	Replace		.5		44		
2202-06	Windshield Wiper Motor	Replace		4.0		44		
43	Hydraulic, Fluid, Air and Vacuum System							
4317-01	CTIS Manifold	Replace		13.0		44		
4317-02	CTIS Quick Release Valve, Axle No. 1	Replace		14.0		44		



**Table 1. Maintenance Allocation Chart (MAC) for M-ATV.**

(1)  GROUP NUMBER	(2)  COMPONENT/ ASSEMBLY	(3)  MAINTENANCE FUNCTION	(4) MAINTENANCE LEVEL				(5)  TOOLS AND EQUIPMENT REFERENCE CODE	(6)  REMARKS CODE
			FIELD		SUSTAINMENT			
			CREW	MAINTAINER	BELOW DEPOT	DEPOT		
			C	F	H	D		
4317-03	CTIS Quick Release Valve, Axle No. 2	Replace		2.0			44	
52	Air Conditioning Components	Service		3.0			29, 45	
5200-01	Air Conditioner Compressor (Original Compressor)	Replace		4.5			19, 44	
5200-02	Air Conditioner Compressor (Updated Compressor)	Replace		4.5			19, 44	
5200-03	Air Conditioner Drive Belt	Replace		1.0			44	
5200-04	Air Conditioner Leak Detection	Replace		3.0			24, 45	
5230	Air Conditioner Condenser	Replace		8.0			44	
5247-01	Air Conditioner Receiver/Dryer	Replace		4.0			19, 44	
5247-02	HVAC (Front)	Replace		15.0			45, 53, 54	
5247-03	HVAC (Rear) (M1240/M1240A1)	Replace		8.0			45, 53, 55	
5247-05	HVAC (Rear) (M1245)	Replace		10.0			44	
76	Fire Fighting Equipment							
7639-01	Aerosol Generator (AFES Four Generator System)	Replace		1.0			44	
7639-02	Aerosol Generator (AFES Five Generator System)	Replace		1.0			44	

**Table 1. Maintenance Allocation Chart (MAC) for M-ATV.**

(1)  GROUP NUMBER	(2)  COMPONENT/ ASSEMBLY	(3)  MAINTENANCE FUNCTION	(4) MAINTENANCE LEVEL				(5)  TOOLS AND EQUIPMENT REFERENCE CODE	(6)  REMARKS CODE
			FIELD		SUSTAINMENT			
			CREW	MAINTAINER	BELOW DEPOT	DEPOT		
			C	F	H	D		
7639-03	Fire Suppression System Capsule Cylinder (Platform Mount)	Replace		2.0			44	
7639-04	Fire Suppression System Capsule Cylinder (Wall Mount) (M1240/ M1240A1)	Replace		2.0			19, 44	
		Inspect		2.5			32	
7639-05	Fire Suppression System Chassis Switch	Replace		1.0			44	
7639-06	Fire Suppression System Control	Replace		1.0			44	
7639-07	Fire Suppression System Control Head Adapter	Replace		2.0			44	
7639-08	Fire Suppression System Front Optical Sensor	Replace		1.0			44	
7639-09	Fire Suppression System Power Supply	Replace		1.0			44	
7639-10	Fire Suppression System Rear Optical Sensor	Replace		1.0			44	

**Table 1. Maintenance Allocation Chart (MAC) for M-ATV.**

(1)  GROUP NUMBER	(2)  COMPONENT/ ASSEMBLY	(3)  MAINTENANCE FUNCTION	(4) MAINTENANCE LEVEL				(5)  TOOLS AND EQUIPMENT REFERENCE CODE	(6)  REMARKS CODE
			FIELD		SUSTAINMENT			
			CREW	MAINTAINER	BELOW DEPOT	DEPOT		
			C	F	H	D		
7639-11	Fire Suppression System Sensor Line (Front) (AFES Nitrogen Detection)	Replace		2.0			44	
7639-12	Fire Suppression System Sensor Line (Rear) (AFES Nitrogen Detection)	Replace		10.0			44	
7639-13	Fire Suppression System Tube and Diffuser (Wall Mount)	Replace		0.5			19, 44	
7639-14	Fire Suppression System Undercarriage (AFES Nitrogen Detection)	Service		1.0			28, 44	
7639-15	Fire Suppression System Undercarriage Cylinder (AFES Nitrogen Detection)	Replace		3.0			44	
7639-16	Fire Suppression System Undercarriage Cylinder (AFES Linear Wire Detection)	Replace		4.8			19, 44, 55, 62	
7639-17	Fire Suppression System Line Replacement Chart, Undercarriage (AFES Nitrogen Detection)	Replace		3.0			44	

**Table 1. Maintenance Allocation Chart (MAC) for M-ATV.**

(1)  GROUP NUMBER	(2)  COMPONENT/ ASSEMBLY	(3)  MAINTENANCE FUNCTION	(4) MAINTENANCE LEVEL				(5)  TOOLS AND EQUIPMENT REFERENCE CODE	(6)  REMARKS CODE
			FIELD		SUSTAINMENT			
			CREW	MAINTAINER	BELOW DEPOT	DEPOT		
			C	F	H	D		
7639-18	Fire Suppression System Line Replacement Chart, Undercarriage (AFES Linear Wire Detection)	Replace		3.0			44	
7639-19	Fire Suppression Systems	Test		3.0			43, 44	

**Table 2. Tools and Test Equipment for M-ATV**

Tool or Test Equipment	Maintenance Level	Nomenclature	National Stock Number	Tool Number
1	F	52 MM Socket		9SIA0PZ05V5602
2	F	Adapter Kit, Transmission Jack	4910-01-602-9693	95SK415
3	F	Adapter, Torque Wrench, 30 mm		GSRM430
4	F	Adapter, Torque Wrench, 5/8 in.	5120-01-367-3583	SRES20
5	F	Ball Valve, 3/8 in	4820-00-541-5198	16B100
6	F	Bolt, Crankshaft Seal Installer	5306-01-360-2004	1U-7596
7	F	Boot Driver	2520-01-481-0382	3369823
8	F	Bracket, Transmission Holding	2590-01-475-7886	J35926-A
9	F	Bracket, Transmission Lifting	5340-01-475-3497	J41445
10	F	Crimping Tool, Terminal Hand	5120-01-374-8836	J-38852
11	F	Driver, Bearing 2 In.	5120-01-480-2320	3061982
12	F	Driver, Bearing, 60 MM	5120-01-485-3173	3351597
13	F	Driver, Seal, CTIS	5330-01-480-2323	2209580
14	F	Elbow, Quick Disconnect	4730-01-572-5350	KV2L07-36S

**Table 2. Tools and Test Equipment for M-ATV (Continued)**

<b>Tool or Test Equipment</b>	<b>Maintenance Level</b>	<b>Nomenclature</b>	<b>National Stock Number</b>	<b>Tool Number</b>
15	F	Extractor, Electrical Connector Plug	5120-01-485-3155	2HB267
16	F	Eye Bolt	5306-01-529-6523	3100T11
17	F	Forward Repair System	4940-01-533-1621	SC4940-95-E42
18	F	Gauge, Belt Tension	6635-01-093-3710	BT-33-73F
19	F	Inflation Tool Kit	5220-01-609-4755	MS120011133
20	F	Kit, Leak Detection	4940-01-521-4469	TLK-100BZ/FB
21	F	Locator Assembly	4910-01-362-2331	1328772
22	F	Locknut	5310-01-479-0716	3266310
23	F	Nut Assembly	5310-01-038-8318	9S8858
24	F	Recharge Kit, Fire Extinguisher	4210-01-582-3743	600213
25	F	Reclaimer, Refrigerant	4250-01-411-7240	17800B
26		Regulator, Torpedo	1045-00-433-7957	3200300
27	F	Remover, Electrical Connector	5120-01-394-0296	305193
28	F	Scale, Weighing	6670-01-522-7835	TIF9010A
29	F	Screw	5305-01-305-6078	1536340
30	F	Seal Installer	5120-01-372-8799	1U-7594
31	F	Setscrew, Plain Cup, M24-3.0x50 mm Din 916	5305-01-599-0240	27KP516
32	F	Shackles	4030-01-586-0713	5340000467-00
33	F	Single Stud Ring	5306-01-529-6523	3100T11
34	F	Sling Assembly	3940-01-209-6008	
35	F	Socket, Turning Tool, Engine	4910-01-548-0012	178-8615
36	F	Spline Cover	5120-01-480-2322	3301788
37	F	Strap, 20 Ft	5340-01-586-0830	EEZ-903PMEX20
38	F	Strap, Ratchet	3990-01-542-1553	8834T48
39	F	Test Kit, AFES	4210-01-579-5981	19263-01
40	F	Tool Kit, General Mechanic's	5180-01-548-7634	PD484
41	F	Tool Kit, Refrigeration Equipment	5180-00-596-1474	SC 5180-90-CL-N18

**Table 2. Tools and Test Equipment for M-ATV (Continued)**

<b>Tool or Test Equipment</b>	<b>Maintenance Level</b>	<b>Nomenclature</b>	<b>National Stock Number</b>	<b>Tool Number</b>
42	F	Tool Set, SATS Base	4910-01-490-6453	SC4910-95-A81
43	F	Tool, Removal, Brake Return Spring	5120-01-480-2324	3350279
44	F	Wrench, Spindle Nut	5120-01-480-2328	3298841
45	F	Wrench, Torque, 20-100 Ft-Lb, 3/8" Drive	5120-01-400-0237	AS28431
46	F	Wrench, Torque, 40-200 In-Lb, 3/8" Drive	5120-01-400-0233	6064A
47	F	Wrench, Torque, Dial, 1/4" Drive, 30 In-Lb		KTC S0986
48	F	Wrench, Torque, Dial, 3/8" Drive, 300 In-Lb		KTC S0987
49	F	Yoke and Flange Holder	5120-01-166-0573	J-3456
50	F	Nut	5310-01-063-8970	95862
51	F	Screw	5305-01-352-2049	1754290
52	F	Remover Electrical Connector	5120-01-374-8969	J-36400-5
53	F	Remover Electrical Connector	5120-01-015-2154	91019-3
54	F	Remover Electrical Connector	5120-01-353-2534	J-33095-1
55	F	Cap and Plug Set	5340-00-450-5718	10935405
56	F	Strap, Nylon, 60 in.	5340-01-599-0238	3967774
57	F	Crow Foot Attachment, Socket Wrench, 9/16 in.	5120-01-335-1152	FC 018A
58	F	Elbow, Pipe to Tube	4730-01-599-0179	3953273
59	F	Maintenance Support Device (MSD)	6625-01-573-3383	DG-MRAP-CDK

*Table 3. Remarks for M-ATV.*

Remark Code	Remarks
-	No Remarks

END OF WORK PACKAGE





---

**EXPENDABLE AND DURABLE ITEMS LIST**

---

**SCOPE**

This work package lists expendable and durable items needed to operate and maintain the M-ATV.

**EXPLANATION OF COLUMNS**

**a. Column (1) - Item Number.** This number is assigned to the entry in the listing and may be referenced in Initial Setup area to identify the material.

**b. Column (2) - National Stock Number.** This is the National Stock Number assigned to the item; use it to request or requisition the item.

**c. Column (3) - Description/Part Number (CAGEC).** Indicates the Federal Item name, part number, and the Commercial and Government Entity (CAGE) Code.

**d. Column (4) - Unit of Measure (U/M).** Indicates the measure used in performing the actual maintenance function. This measure is expressed by two-character alphabetical abbreviations (e.g., EA, IN, PR). If the unit of measure differs from the unit of issue, requisition the lowest unit of issue that will satisfy your requirements.

**Table 1. Expendable and Durable Items List.**

(1) Item Number	(2) National Stock Number	(3) Description/Part Number (CAGEC)	(4) U/M
1	8040-00-148-7182	Adhesive 5 oz Tube	TU
2	8040-01-517-1610	Adhesive (Novagard) RTV200-257, (00CE9)	
3	5330-01-325-6993 8030-01-137-6964 8030-01-262-3560	Adhesive-Sealant, Loctite 515 515, (05972), 6-milliliter tube 51531, (05972), Ten 50-milliliter tubes 51574, (05972), 300-milliliter tube	EA BX TU
4	8040-00-843-0802	Adhesive-Sealant, Silicone, RTV (MIL-A-46106A) RTV108-2.8 oz, (01139), 2.8-ounce cartridge	KT
5	8040-01-566-0125	Adhesive, Sika #221 Gray 1490170, (45152)	
6	8040-01-250-3969	Adhesive, Thread Locking, Loctite 242 242, (05972), 50 ml Bottle	BT
7	6850-01-464-9266 6850-01-464-9263 6850-01-464-9096	Antifreeze, Ethylene Glycol (60%), Inhibited Type 1B 1 gal, A-A-52624 (58536) 5 gal, A-A-52624 (58536) 55 gal, A-A-52624 (58536)	GL CO DR

**Table 1. Expendable and Durable Items List. (Continued)**

(1) Item Number	(2) National Stock Number	(3) Description/Part Number (CAGEC)	(4) U/M
8	5975-01-273-8133	Cable Ties (Strap, Tiedown, Electrical Components) MS3367-3, (96906)	HD
9	5340-00-450-5718	Cap and Plug Set 10935405, (19207)	EA
10	5970-01-551-5155	Connector, Lubricant, Nyogel 760G 2200400 (45152)	EA
11	8010-01-523-1208	Coating, Primer TG-12	
12	8010-01-521-8653	Compound, Anti-Corrosion Spray 2233850, (45152), 11-oz spray can	
13	6850-01-515-2449	Compound, Anti-Corrosion VCI 325 3450736, (45152)	EA
14	8030-01-450-4009	Compound, Corrosion Preventative TG-1, (05SA2)	OZ
15	8030-01-166-0675	Compound, Sealing, Loctite 567 567 (05972)	TU
16	8030-01-218-0321	Compound, Sealing MS-PTS-50, (02570), 50 milliliter Tube	TU
17	8040-01-042-1422	Compound, Sealing, Flowable 1204 RTV Prime Coat (71984), 1 pint can	PT
18	8040-01-009-1562	Silicone, Sealant, Primer (Dow Coating 1204), (27963) Compound, Sealing, Flowable MIL-A-46146 (81349)	KT
19	8030-01-104-5392	Silicone, Sealant, Sealant (Dow Coating 3140), (81349) Compound, Sealing, Loctite 242, Type 2, Grade N 24221, (05981), Ten 10-Milliliter bottles	BX
20	8030-01-025-1692 8030-01-014-5869 8030-01-054-0740	MIL-S-46163, (81349), 250-Milliliter centimeter bottle MIL-S-46163, (81349), 50-Milliliter centimeter bottle Compound, Sealing, Loctite 592 (321410), Ten 50-Milliliter tubes	BT BT BX
21	8030-01-211-9576	Compound, Sealing, Torque F-1000, (01195)	OZ

**Table 1. Expendable and Durable Items List. (Continued)**













(1) Item Number	(2) National Stock Number	(3) Description/Part Number (CAGEC)	(4) U/M
22	6850-01-474-2319 6850-01-474-2317 6850-01-474-2316	Cleaning Compound, Solvent, Type II MIL-PRF-680 (81349), 1-gallon can MIL-PRF-680 (81349), 5-gallon can MIL-PRF-680 (81349), 55-gallon drum	GL CO DR
23	5320-01-599-0178	Fastener Tape, Hook and Pile, 50 yards 3797012 (45152)	EA
24	9150-01-197-7688 9150-01-197-7693 9150-01-197-7690 9150-01-197-7689 9150-01-197-7692 9150-01-197-7691	Grease, Automotive and Artillery (GAA) (MIL-G-10924) M-10924-A, (81349), 2-1/4-ounce tube M-10924-B, (81349), 14-ounce cartridge M-10924-C, (81349), 1-3/4-ounce can M-10924-D, (81349), 6-1/2-pound can M-10924-E, (81349), 35-pound can M-10924-F, (81349), 120-pound drum	TU CA CN CN CN DR
25	9150-00-076-1587	Grease, Lubriplate LUBRIPLATE110, (73219), 8-ounce tube	TU
26	5970-01-342-1742	Heatshrink 603314-4, (00779)	EA
27	6810-01-075-5546	Isopropyl, Rubbing Alcohol 4 oz Bottle	BT
28	9505-00-191-3680	Lockwire (Wire, Nonelectrical) ASTM A853, (81349)	LB
29	9150-00-111-3199	Lubricating, Oil, Engine, Grade 10 M21260-3-10W, (81349), 5 GL	CN
30	9150-00-111-0208	Lubricating, Oil, Engine, Grade 10 MIL-PRF-21260, (81349), 55-gallon drum	DR
31	9150-00-111-0209	Lubricating, Oil, Engine, Grade 30 M21260-3-30W, (81349), 5-gallon can	CN
32	9150-00-111-0210	Lubricating, Oil, Engine, Grade 30 M21260-4-30W, (81349), 55-gallon drum	DR
33	7930-01-585-0017	Lubricant and Cleaning Compound 8T-2998, (11083)	EA
34	5970-01-551-5155	Lubricant, Connector 2200400, (45152)	EA
35	9150-01-035-5390 9150-01-035-5391	Oil, Lubricating, Gear GO 75 (MIL-L-2105) M2105-1-75W, (81349), 1-quart can MIL-PRF-2105, (81349), 5-gallon can	QT CN
36	9150-01-035-5393	Oil, Lubricating, Gear, GO 80W/90 (MIL-L-2105C) J2360, (81343), 5-gallon can	CN

**Table 1. Expendable and Durable Items List. (Continued)**

(1) Item Number	(2) National Stock Number	(3) Description/Part Number (CAGEC)	(4) U/M
37	9150-01-035-5395 9150-01-035-5396	Oil, Lubricating, Gear GO 85W/140 (MIL-L-2105) J2360, (81343), 5-gallon can J2360, (81343), 55-gallon drum	CN DR
38	9150-01-518-9477	Oil, Lubricating, OE/HDO 40 (SAE 40) (MIL-L-2104) MIL-PRF-2104, (81349), 1-quart can	QT
39	6640-01-128-9471	Paper, Lens	PG
40	7920-00-205-1711	Rag, Wiping Cotton 50 lbs Bale	BE
41	9150-01-546-5096	Refrigerant, Compressor Lubricating Oil	GL
42	7930-00-497-1582	Solution, Soap MILW15000ClassC, (81349), 1-quart bottle	QT
43	8135-00-178-9200	Tags, Identification, White 8135-00-178-9200, (80244), 1000 per carton	BX
44	5970-00-644-3167	Tape, Insulation, Electrical TL83, (80063), 3/4 inch wide, 1020 inch long	RO
45	6810-01-412-6362	Tetrafluoroethane, Technical, R-134A, 30 lbs	CY

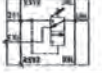

















**END OF WORK PACKAGE**



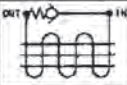







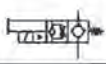



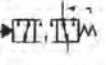

**SCHEMATICS SYMBOLS**



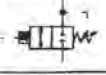



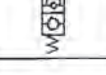









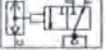

EXPLANATION OF OSHKOSH TRUCK CORPORATION AIR SCHEMATIC SYMBOLS			
OTC SYMBOL	DEFINITION	OTC SYMBOL	DEFINITION
	AIR REGULATOR VALVE		SPRING BRAKE VALVE
	MANIFOLD		BULKHEAD FITTING
	AIR BAG		QUICK RELEASE VALVE
	PARKING BRAKE VALVE TRACTOR/TRAILER		DUAL TREADLE VALVE
	AIR GOVERNOR		AIR COMPRESSOR
	TRACTOR PROTECTION VALVE		COALESCING FILTER
	AFTERCOOLER		







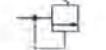

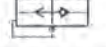



EXPLANATION OF OSHKOSH TRUCK CORPORATION HYDRAULIC SCHEMATIC SYMBOLS			
OTC SYMBOL	DEFINITION	OTC SYMBOL	DEFINITION
	SHUTTLE VALVE/DOUBLE CHECK		PILOT OPERATED CONTROL VALVE
	NEEDLE VALVE		MANIFOLD
	ANTI-CAVITATION MANIFOLD		ROTATING SHAFT
	ACCUMULATOR, GAS CHARGED		DUAL COUNTERBALANCE/ HOLDING VALVE
	CYLINDER		SOLENOID DIRECTIONAL CONTROL VALVE 4-WAY 2 POSITION
	MOTOR AND DRUM		SOLENOID DIRECTIONAL CONTROL VALVE 4-WAY 3 POSITION SPOOL TYPE
	MOTOR DRIVEN SWING HOIST WITH BRAKE		PRESSURE SWITCH
	MOTOR DRIVEN HOIST DRIVE WITH BRAKE		SOLENOID DIRECTIONAL CONTROL VALVE 2-WAY 2 POSITION





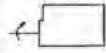









































EXPLANATION OF OSHKOSH TRUCK CORPORATION HYDRAULIC SCHEMATIC SYMBOLS			
QTC SYMBOL	DEFINITION	QTC SYMBOL	DEFINITION
	STEEL TUBE		NORMALLY CLOSED PRESSURE SWITCH
	WORKING LINE, RETURN LINE AND FEED LINE		VARIABLE DISPLACEMENT, PRESSURE COMPENSATED, TANDEM PUMP
	PILOT CONTROL LINE		FAN MOTOR/FIXED DISPLACEMENT
	ENCLOSURE INDICATES EXTREMITY OF COMPONENT OR ASSEMBLY		HAND PUMP
	VALVE		VARIABLE DISPLACEMENT PUMP
	CHECK VALVE		RESERVOIR
	ORFICE		OIL COOLER WITH CHECK VALVE
	BULKHEAD ADAPTER/FITTING		RESERVOIR RETURN FILTER WITH BYPASS
	QUICK DISCONNECTS WITH CHECKS		FILTER WITH BYPASS
	TEST PORT		FILTER/STRAINER

EXPLANATION OF OSHKOSH TRUCK CORPORATION HYDRAULIC SCHEMATIC SYMBOLS			
OTC SYMBOL	DEFINITION	OTC SYMBOL	DEFINITION
	SOLENOID DIRECTIONAL CONTROL VALVE 3-WAY 2-POSITION POPPET TYPE		DIRECTIONAL CONTROL SOLENOID VALVE, 2-WAY 2-POSITION POPPET TYPE, NORMALLY CLOSED
	SOLENOID DIRECTIONAL CONTROL VALVE 2-WAY 2-POSITION		DIRECTIONAL CONTROL VALVE, 3-POSITION, 4-WAY, CLOSED CENTER SPOOL WITH CYLINDER PORTS OPEN TO TANK AT NEUTRAL
	DIFFERENTIAL PRESSURE SENSING VALVE		PILOT OPERATED VALVE, SPOOL TYPE 2-POSITION, 4-WAY
	DIFFERENTIAL PRESSURE SENSING VALVE, FLOW CONTROL, SPOOL TYPE, NORMALLY OPENED		PILOT OPERATED DIRECTIONAL CONTROL VALVE 3-WAY 2-POSITION
	SOLENOID VALVE 4-WAY 2-POSITION SPOOL TYPE		PRIORITY FLOW VALVE
	SOLENOID VALVE 2-WAY 2-POSITION SPOOL TYPE, NORMALLY OPEN		SOLENOID DIRECTIONAL CONTROL VALVE 2-WAY 2-POSITION POPPET TYPE
	SOLENOID VALVE 2-WAY 2-POSITION SPOOL TYPE, NORMALLY CLOSED		CHECK VALVE, DIRECT-ACTING WITH THERMAL EXPANSION RELIEF FUNCTION
	CLOSED CENTER SPOOL VALVE		SOLENOID DIRECTIONAL CONTROL VALVE 2-WAY 2-POSITION POPPET TYPE
	PRESSURE SEQUENCE VALVE		
	PRESSURE RELIEF VALVE		

EXPLANATION OF OSHKOSH TRUCK CORPORATION AIR SCHEMATIC SYMBOLS			
OTC SYMBOL	DEFINITION	OTC SYMBOL	DEFINITION
	PRESSURE SWITCH N.O.		BRAKE CHAMBER: SERVICE AND SPRING
	PRESSURE GAUGE		BRAKE CHAMBER: SERVICE
	HAND CONTROL VALVE		SERVICE BRAKE RELAY VALVE
	SOLENOID VALVE WITH RETURN SPRING		SPRING BRAKE RELAY VALVE
	HORN		AIR RESERVOIR
	DOUBLE CHECK VALVE		AIR DRYER
	CHECK VALVE: SPRING RETURN		GLAD HAND
	DRAIN VALVE		LOAD SENSING VALVE
	DRAIN VALVE: AUTOMATIC CLOSING		PRESSURE PROTECTION VALVE
	PRESSURE SWITCH N.C.		QUICK RELEASE VALVE

EXPLANATION OF OSHKOSH TRUCK CORPORATION AIR SCHEMATIC SYMBOLS			
DTC SYMBOL	DEFINITION	DTC SYMBOL	DEFINITION
	AIR REGULATOR VALVE		SPRING BRAKE VALVE
	MANIFOLD		BULKHEAD FITTING
	AIR BAG		QUICK RELEASE VALVE
	PARKING BRAKE VALVE TRACTOR/TRAILER		DUAL TREADLE VALVE
	AIR GOVERNOR		AIR COMPRESSOR
	TRACTOR PROTECTION VALVE		COALESCING FILTER
	AFTERCOOLER		



















EXPLANATION OF OSHKOSH TRUCK CORPORATION ELECTRICAL SCHEMATIC SYMBOLS			
OTC SYMBOL	DEFINITION	OTC SYMBOL	DEFINITION
	RELAY DIODE SUPPRESSED		SWITCH, ON-OFF-ON DPDT
	RELAY RESISTOR SUPPRESSED		SWITCH, ON-ON SPDT
	RELAY		SWITCH, OFF-ON DPST
	SWITCH, ROTARY OFF-ON-ON-ON		SWITCH, ARCTIC PUMP ILLUMINATED
	SWITCH, OFF-ON SPST		PRESSURE SWITCH N.O.
	SWITCH, IGNITION		PRESSURE SWITCH N.C.
	SWITCH, OFF-ON-ON ILLUMINATED		TEMPERATURE SWITCH N.O.
	SWITCH, OFF-ON DIMMER		TEMPERATURE SWITCH N.C.
	SWITCH, DPDT ILLUMINATED		PROXIMITY SENSING SWITCH
	SWITCH, OFF-ON-ON DPDT ILLUMINATED		SWITCH, N.O. SPST FOOT OPERATED

EXPLANATION OF OSHKOSH TRUCK CORPORATION ELECTRICAL SCHEMATIC SYMBOLS			
OTC SYMBOL	DEFINITION	OTC SYMBOL	DEFINITION
	ODOMETER		MULTIPLE CONNECTOR
	SPEEDOMETER, TACHOMETER		CIRCUIT BREAKER
	VERNIER CONTROL		LED - LIGHT EMITTING DIODE
	RESISTOR		TRANSORB DIODE
	DIODE		ZENIOR DIODE
	DIODE PACK		CAPACITOR
	ISOLATOR/DIODE		NAND GATE
	DIODE/RECTIFIER		FUSE
	BATTERY		TRANSISTOR
	INCANDESCENT LAMP (LIGHT BULB)		COIL/RELAY
	CONNECTOR		TIMER
	MOMENTARY SWITCH		SWITCH LOCK (Not Electrical Component)



EXPLANATION OF OSHKOSH TRUCK CORPORATION ELECTRICAL SCHEMATIC SYMBOLS			
OTC SYMBOL	DEFINITION	OTC SYMBOL	DEFINITION
	SWITCH, N.O. DRIVE LINE LOCK		REVERSE POLARITY PROTECTION 200 AMP
	COIL		ALTERNATOR, 145 AMP
	GAUGE		ALTERNATOR, 200 AMP
	HEATING ELEMENT		SENSOR
	SENDING UNIT, TEMPERATURE		SENSOR, ADJUSTABLE
	SPEEDOMETER GENERATOR		SENSOR, VARIABLE
	MOTOR		MAG SWITCH
	ALARM		TURN SIGNAL FLASHER
	MOTOR, WIPER		MOTOR, SUPPRESSED VARIABLE SPEED
	DUVAC CONTROLLER WITH REVERSE POLARITY PROTECTION 145 AMP		SOLENOID - VALVE



EXPLANATION OF OSHKOSH TRUCK CORPORATION HYDRAULIC SCHEMATIC SYMBOLS			
OTC SYMBOL	DEFINITION	OTC SYMBOL	DEFINITION
	SOLENOID DIRECTIONAL CONTROL VALVE 3-WAY 2-POSITION POPPET TYPE		DIRECTIONAL CONTROL SOLENOID VALVE - 2-WAY 2-POSITION POPPET TYPE, NORMALLY CLOSED
	SOLENOID DIRECTIONAL CONTROL VALVE 2-WAY 2-POSITION		DIRECTIONAL CONTROL VALVE - 3 POSITION, 4 WAY - CLOSED CENTER SPOOL WITH CYLINDER PORTS OPEN TO TANK AT NEUTRAL
	DIFFERENTIAL PRESSURE SENSING VALVE		PILOT OPERATED VALVE - SPOOL TYPE 2 POSITION, 4 WAY
	DIFFERENTIAL PRESSURE SENSING VALVE, FLOW CONTROL - SPOOL TYPE, NORMALLY OPENED		PILOT OPERATED DIRECTIONAL CONTROL VALVE 3-WAY 2-POSITION
	SOLENOID VALVE 4-WAY 2-POSITION SPOOL TYPE		PRIORITY FLOW VALVE
	SOLENOID VALVE 2-WAY 3-POSITION SPOOL TYPE, NORMALLY OPEN		SOLENOID DIRECTIONAL CONTROL VALVE 2-WAY 2-POSITION POPPET TYPE
	SOLENOID VALVE 2-WAY 2-POSITION SPOOL TYPE, NORMALLY CLOSED		CHECK VALVE, DIRECT-ACTING WITH THERMAL EXPANSION RELIEF FUNCTION
	CLOSED CENTER SPOOL VALVE		SOLENOID DIRECTIONAL CONTROL VALVE 2-WAY 2-POSITION POPPET TYPE
	PRESSURE SEQUENCE VALVE		
	PRESSURE RELIEF VALVE		

END OF WORK PACKAGE

<b>RECOMMENDED CHANGES TO PUBLICATIONS AND BLANK FORMS</b>						Use Part II (reverse) for Repair Parts and Special Tool Lists (RPSTL) and Supply Catalogs/Supply Manuals (SC/SM).	DATE <i>Date you filled out this form.</i>
For use of this form, see AR 25-30; the proponent agency is OAASA.							
<b>TO</b> (Forward to proponent of publication or form) (Include ZIP Code) U.S. Army TACOM Life Cycle Management Command ATTN: AMSTA-LCL-MPP/TECH PUBS, MS 727 6501 E. 11 Mile Road, Warren, MI 48397-5000						<b>FROM</b> (Activity and location) (Include ZIP Code) <i>Your mailing address</i>	
<b>PART I – ALL PUBLICATIONS (EXCEPT RPSTL AND SC/SM) AND BLANK FORMS</b>							
PUBLICATION/FORM NUMBER <i>TM Number</i>						DATE <i>Date of the TM</i>	TITLE <i>Title of the TM</i>
ITEM	PAGE	PARA-GRAPH	LINE	FIGURE NO.	TABLE	RECOMMENDED CHANGES AND REASON (Exact wording of recommended change must be given)	
	0007-3					<i>Figure 2, Item 9 should show a lockwasher. Currently shows a flat washer.</i>	
	0018-2					<i>Cleaning and inspection, Step 6, reference to governor support pin (14) is wrong reference. Reference should be change to (12).</i>	
<h1>SAMPLE</h1>							
TYPED NAME, GRADE OR TITLE  <i>Your Name</i>						TELEPHONE EXCHANGE/AUTOVON, PLUS EXTENSION  <i>Your Phone Number</i>	SIGNATURE  <i>Your Signature</i>

<b>TO</b> <i>(Forward direct to addressee listed in publication)</i> U.S. Army TACOM Life Cycle Management Command ATTN: AMSTA-LCL-MPP/TECH PUBS, MS 727 6501 E. 11 Mile Road, Warren, MI 48397-5000	<b>FROM</b> <i>(Activity and location) (Include ZIP Code)</i>  <i>Your Address</i>	<b>DATE</b> <i>Date you filled out this form</i>
---	--	---

**PART II – REPAIR PARTS AND SPECIAL TOOL LISTS AND SUPPLY CATALOGS/SUPPLY MANUALS**

PUBLICATION NUMBER <i>TM Number</i>	DATE <i>Date of the TM</i>	TITLE <i>Title of the TM</i>
--	-------------------------------	---------------------------------

PAGE NO.	COLM NO.	LINE NO.	NATIONAL STOCK NUMBER	REFERENCE NO.	FIGURE NO.	ITEM NO.	TOTAL NO. OF MAJOR ITEMS SUPPORTED	RECOMMENDED ACTION
<h1>SAMPLE</h1>								

**PART III – REMARKS** *(Any general remarks, or recommendations, or suggestions for improvement of publications and blank forms. Additional blank sheets may be used if more space is needed.)*

TYPED NAME, GRADE OR TITLE <i>Your Name</i>	TELEPHONE EXCHANGE/AUTOVON, PLUS EXTENSION <i>Your Phone Number</i>	SIGNATURE <i>Your Signature</i>
--	--	------------------------------------

<b>RECOMMENDED CHANGES TO PUBLICATIONS AND BLANK FORMS</b>						Use Part II (reverse) for Repair Parts and Special Tool Lists (RPSTL) and Supply Catalogs/Supply Manuals (SC/SM).	<b>DATE</b>
For use of this form, see AR 25-30; the proponent agency is OAASA							
<b>TO</b> (Forward to proponent of publication or form) (Include ZIP Code) U.S. Army TACOM Life Cycle Management Command ATTN: AMSTA-LCL-MPP/TECH PUBS, MS 727 6501 E. 11 Mile Road, Warren, MI 48397-5000						<b>FROM</b> (Activity and location) (Include ZIP Code)	
<b>PART I – ALL PUBLICATIONS (EXCEPT RPSTL AND SC/SM) AND BLANK FORMS</b>							
PUBLICATION/FORM NUMBER TM 9-2355-335-23-2						DATE 28 February 2013	TITLE MAINTENANCE MANUAL FOR MINE RESISTANT AMBUSH PROTECTED VEHICLE
	PAGE	PARA-GRAPH	LINE	FIGURE NO.	TABLE	RECOMMENDED CHANGES AND REASON	
TYPED NAME, GRADE OR TITLE					TELEPHONE EXCHANGE/AUTOVON, PLUS EXTENSION		SIGNATURE

<b>TO</b> (Forward direct to addressee listed in publication) U.S. Army TACOM Life Cycle Management Command ATTN: AMSTA-LCL-MPP/TECH PUBS, MS 727 6501 E. 11 Mile Road, Warren, MI 48397-5000	<b>FROM</b> (Activity and location) (Include ZIP Code)	<b>DATE</b>
--	--	-------------

**PART II – REPAIR PARTS AND SPECIAL TOOL LISTS AND SUPPLY CATALOGS/SUPPLY MANUALS**

PUBLICATION/FORM NUMBER TM 9-2355-335-23-2	DATE 28 February 2013	TITLE MAINTENANCE MANUAL FOR MINE RESISTANT AMBUSH PROTECTED VEHICLE
---	--------------------------	--

PAGE NO.	COLM NO.	LINE NO.	NATIONAL STOCK NUMBER	REFERENCE NO.	FIGURE NO.	ITEM NO.	TOTAL NO. OF MAJOR ITEMS SUPPORTED	RECOMMENDED ACTION

**PART III – REMARKS** (Any general remarks, or recommendations, or suggestions for improvement of publications and blank forms. Additional blank sheets may be used if more space is needed.)

TYPED NAME, GRADE OR TITLE	TELEPHONE EXCHANGE/AUTOVON, PLUS EXTENSION	SIGNATURE
----------------------------	--	-----------

<b>RECOMMENDED CHANGES TO PUBLICATIONS AND BLANK FORMS</b>						Use Part II (reverse) for Repair Parts and Special Tool Lists (RPSTL) and Supply Catalogs/Supply Manuals (SC/SM).	<b>DATE</b>
For use of this form, see AR 25-30; the proponent agency is OAASA							
<b>TO</b> (Forward to proponent of publication or form) (Include ZIP Code) U.S. Army TACOM Life Cycle Management Command ATTN: AMSTA-LCL-MPP/TECH PUBS, MS 727 6501 E. 11 Mile Road, Warren, MI 48397-5000						<b>FROM</b> (Activity and location) (Include ZIP Code)	
<b>PART I – ALL PUBLICATIONS (EXCEPT RPSTL AND SC/SM) AND BLANK FORMS</b>							
PUBLICATION/FORM NUMBER TM 9-2355-335-23-2						DATE 28 February 2013	TITLE MAINTENANCE MANUAL FOR MINE RESISTANT AMBUSH PROTECTED VEHICLE
	PAGE	PARA-GRAPH	LINE	FIGURE NO.	TABLE	RECOMMENDED CHANGES AND REASON	
TYPED NAME, GRADE OR TITLE					TELEPHONE EXCHANGE/AUTOVON, PLUS EXTENSION		SIGNATURE

<b>TO</b> (Forward direct to addressee listed in publication) U.S. Army TACOM Life Cycle Management Command ATTN: AMSTA-LCL-MPP/TECH PUBS, MS 727 6501 E. 11 Mile Road, Warren, MI 48397-5000	<b>FROM</b> (Activity and location) (Include ZIP Code)	<b>DATE</b>
--	--	-------------

**PART II – REPAIR PARTS AND SPECIAL TOOL LISTS AND SUPPLY CATALOGS/SUPPLY MANUALS**

PUBLICATION/FORM NUMBER TM 9-2355-335-23-2	DATE 28 February 2013	TITLE MAINTENANCE MANUAL FOR MINE RESISTANT AMBUSH PROTECTED VEHICLE
---	--------------------------	--

PAGE NO.	COLM NO.	LINE NO.	NATIONAL STOCK NUMBER	REFERENCE NO.	FIGURE NO.	ITEM NO.	TOTAL NO. OF MAJOR ITEMS SUPPORTED	RECOMMENDED ACTION

**PART III – REMARKS** (Any general remarks, or recommendations, or suggestions for improvement of publications and blank forms. Additional blank sheets may be used if more space is needed.)

TYPED NAME, GRADE OR TITLE	TELEPHONE EXCHANGE/AUTOVON, PLUS EXTENSION	SIGNATURE
----------------------------	--	-----------



<b>RECOMMENDED CHANGES TO PUBLICATIONS AND BLANK FORMS</b>						Use Part II (reverse) for Repair Parts and Special Tool Lists (RPSTL) and Supply Catalogs/Supply Manuals (SC/SM).	<b>DATE</b>
For use of this form, see AR 25-30; the proponent agency is OAASA							
<b>TO</b> (Forward to proponent of publication or form) (Include ZIP Code) U.S. Army TACOM Life Cycle Management Command ATTN: AMSTA-LCL-MPP/TECH PUBS, MS 727 6501 E. 11 Mile Road, Warren, MI 48397-5000						<b>FROM</b> (Activity and location) (Include ZIP Code)	
<b>PART I – ALL PUBLICATIONS (EXCEPT RPSTL AND SC/SM) AND BLANK FORMS</b>							
PUBLICATION/FORM NUMBER TM 9-2355-335-23-2						DATE 28 February 2013	TITLE MAINTENANCE MANUAL FOR MINE RESISTANT AMBUSH PROTECTED VEHICLE
	PAGE	PARA-GRAPH	LINE	FIGURE NO.	TABLE	RECOMMENDED CHANGES AND REASON	
TYPED NAME, GRADE OR TITLE					TELEPHONE EXCHANGE/AUTOVON, PLUS EXTENSION		SIGNATURE

<b>TO</b> (Forward direct to addressee listed in publication) U.S. Army TACOM Life Cycle Management Command ATTN: AMSTA-LCL-MPP/TECH PUBS, MS 727 6501 E. 11 Mile Road, Warren, MI 48397-5000	<b>FROM</b> (Activity and location) (Include ZIP Code)	<b>DATE</b>
--	--	-------------

**PART II – REPAIR PARTS AND SPECIAL TOOL LISTS AND SUPPLY CATALOGS/SUPPLY MANUALS**

PUBLICATION/FORM NUMBER TM 9-2355-335-23-2	DATE 28 February 2013	TITLE MAINTENANCE MANUAL FOR MINE RESISTANT AMBUSH PROTECTED VEHICLE
---	--------------------------	--

PAGE NO.	COLM NO.	LINE NO.	NATIONAL STOCK NUMBER	REFERENCE NO.	FIGURE NO.	ITEM NO.	TOTAL NO. OF MAJOR ITEMS SUPPORTED	RECOMMENDED ACTION

**PART III – REMARKS** (Any general remarks, or recommendations, or suggestions for improvement of publications and blank forms. Additional blank sheets may be used if more space is needed.)

TYPED NAME, GRADE OR TITLE	TELEPHONE EXCHANGE/AUTOVON, PLUS EXTENSION	SIGNATURE
----------------------------	--	-----------

By Order of the Secretary of the Army:

Official:



JOYCE E. MORROW  
*Administrative Assistant to the  
Secretary of the Army*

1300303

RAYMOND T. ODIERNO  
*General, United States Army  
Chief of Staff*

By Order of the Secretary of the Air Force:

JANET C. WOLFENBARGER  
*General, United States Air Force  
Commander, AFMC*

MARK A. WELSH, III  
*General, United States Air Force  
Chief of Staff*

Distribution:

To be distributed in accordance with the initial distribution number (IDN) 381253 requirements for TM 9-2355-335-23-2.



SCHEMATICS FOR M-ATV M1240/M1240A1

**CAUTION**

Schematics contained in this section are for M-ATV M1240/M1240A1. Do not use these schematics for any other model. Failure to comply may result in damage to equipment.

**TABLE OF SCHEMATICS:**

1. M-ATV Air Schematic
2. M-ATV Electrical Schematic - Capsule Harness
3. M-ATV Electrical Schematic - Engine Harness
4. M-ATV Electrical Schematic - Spotlight Harness
5. M-ATV Electrical Schematic - Chassis Harness
6. M-ATV Electrical Schematic - Engine Harness
7. M-ATV Electrical Schematic - Anti-lock Braking System
8. M-ATV Electrical Schematic - J1939 DATABUS
9. M-ATV Electrical Schematic -HVAC
10. M-ATV Electrical Schematic - Automatic Fire Extinguishing System (AFES)
11. M-ATV Electrical Schematic - Remote Weapon System (RWS) (Optional)
12. M-ATV Electrical Schematic - Check 6 System (Optional)
13. M-ATV Hydraulic Schematic

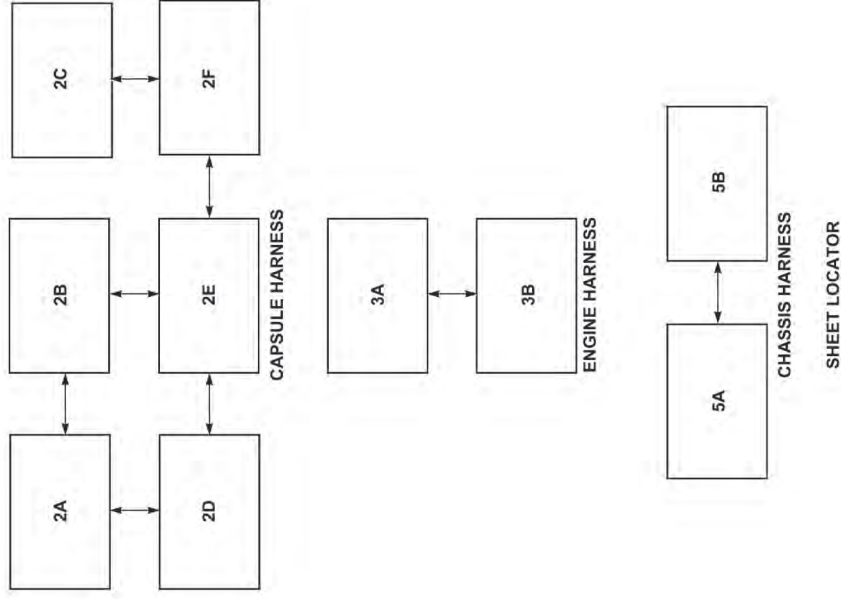



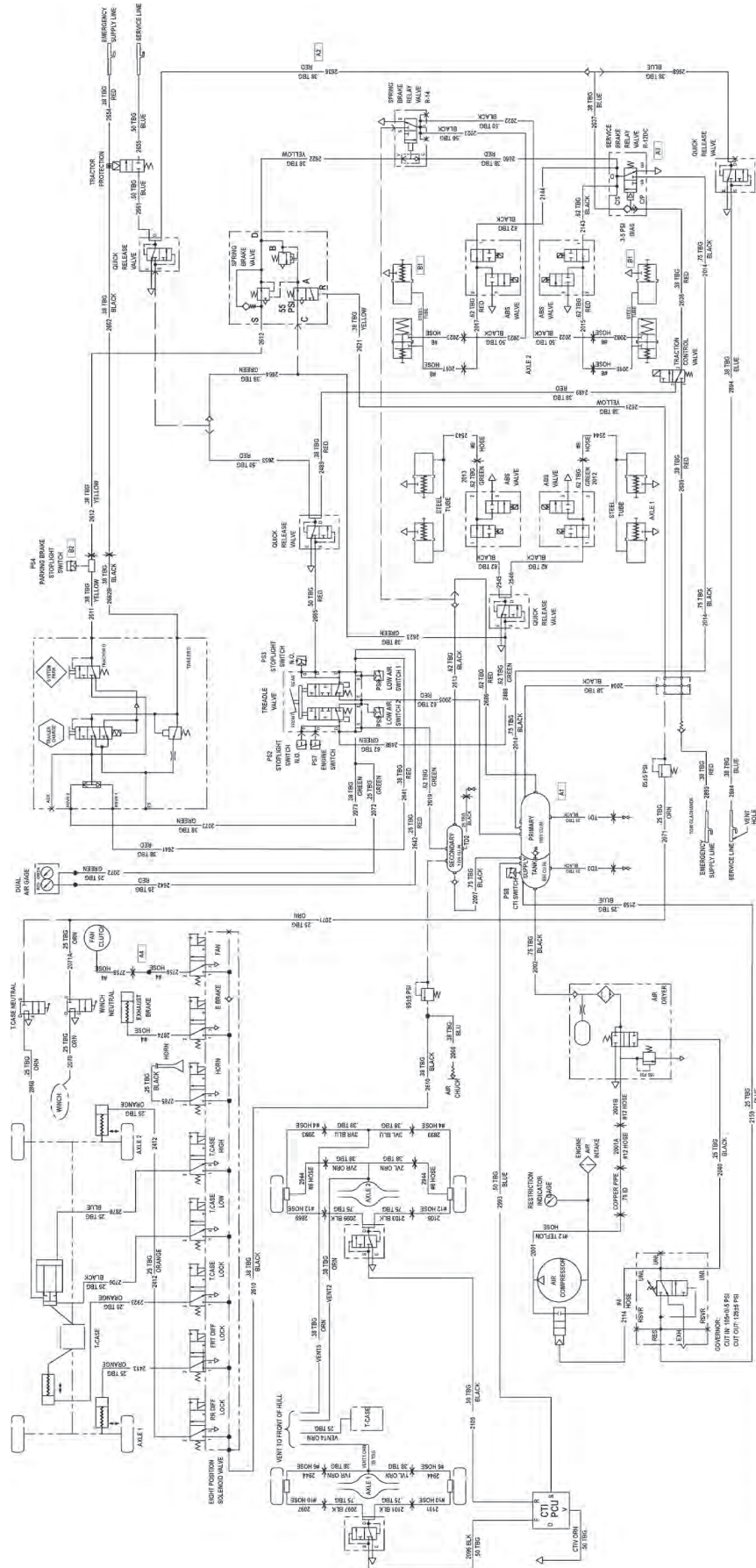

M-ATV SCHEMATIC SHEET 1-A (TWO AIR TANK SYSTEM) (M1240/M1240A1)





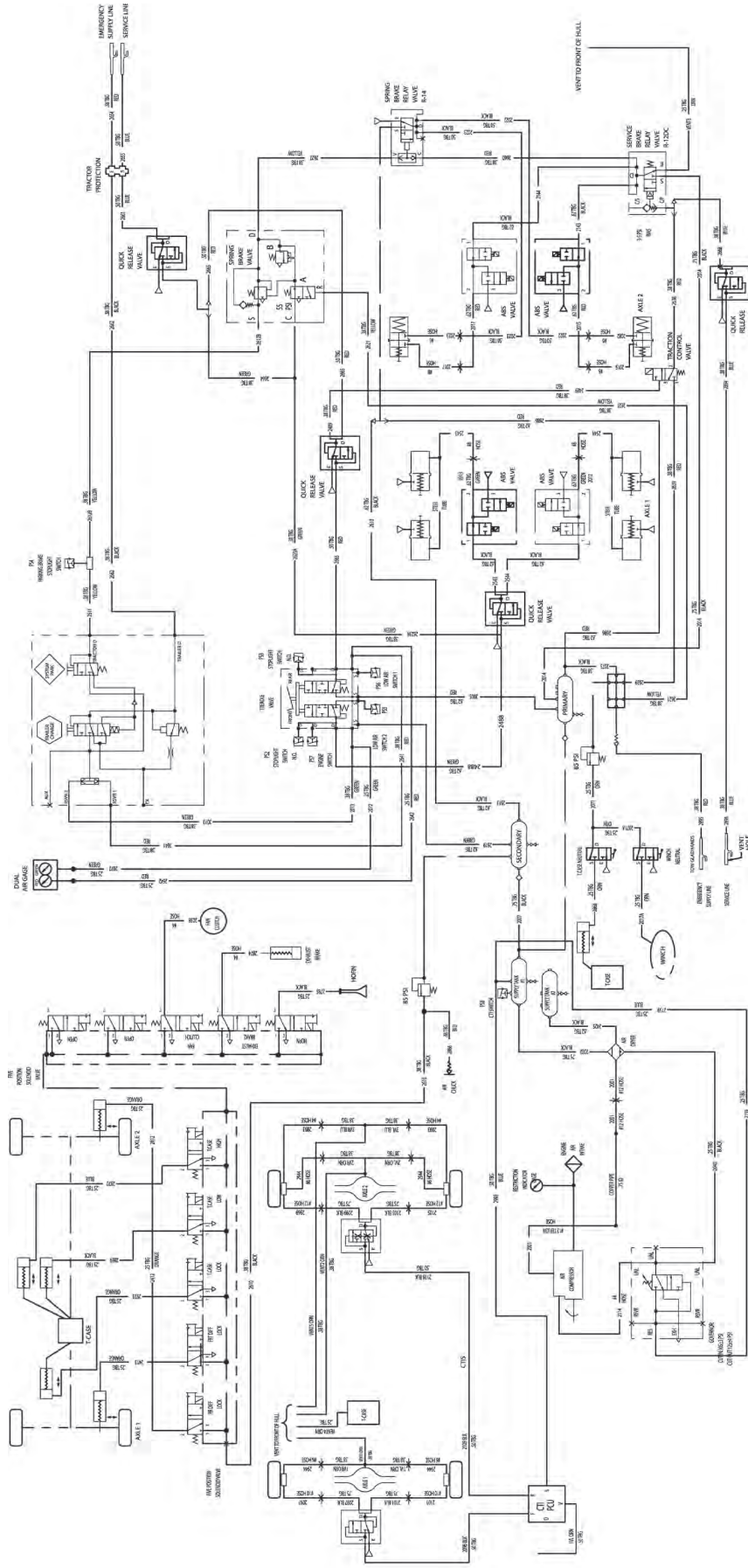

M-ATV SCHEMATIC SHEET 1-B (FOUR AIR TANK SYSTEM) (M1240/1240A1)

















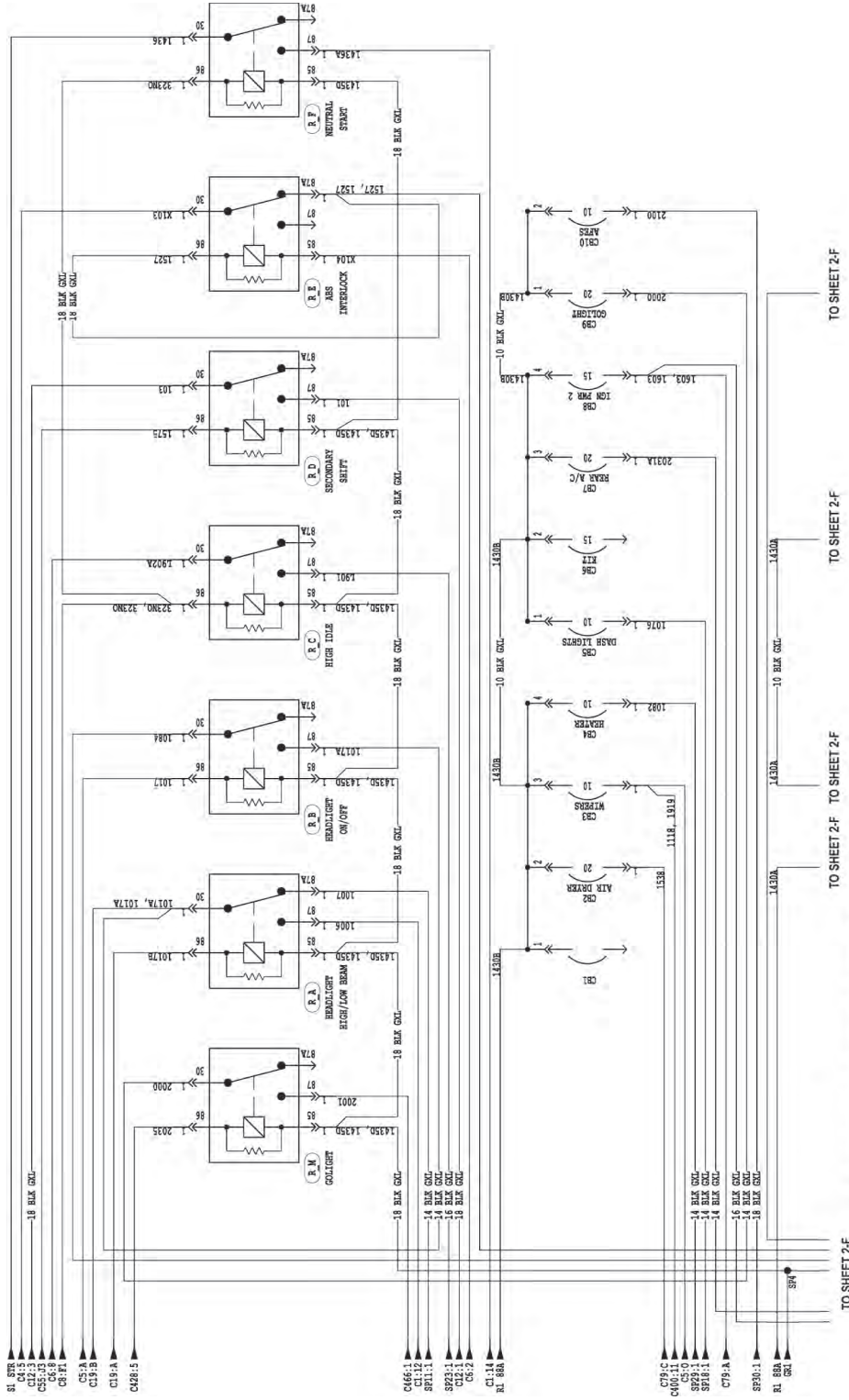

M-ATV ELECTRICAL SCHEMATIC SHEET 2-C (M1240(M1240A1))









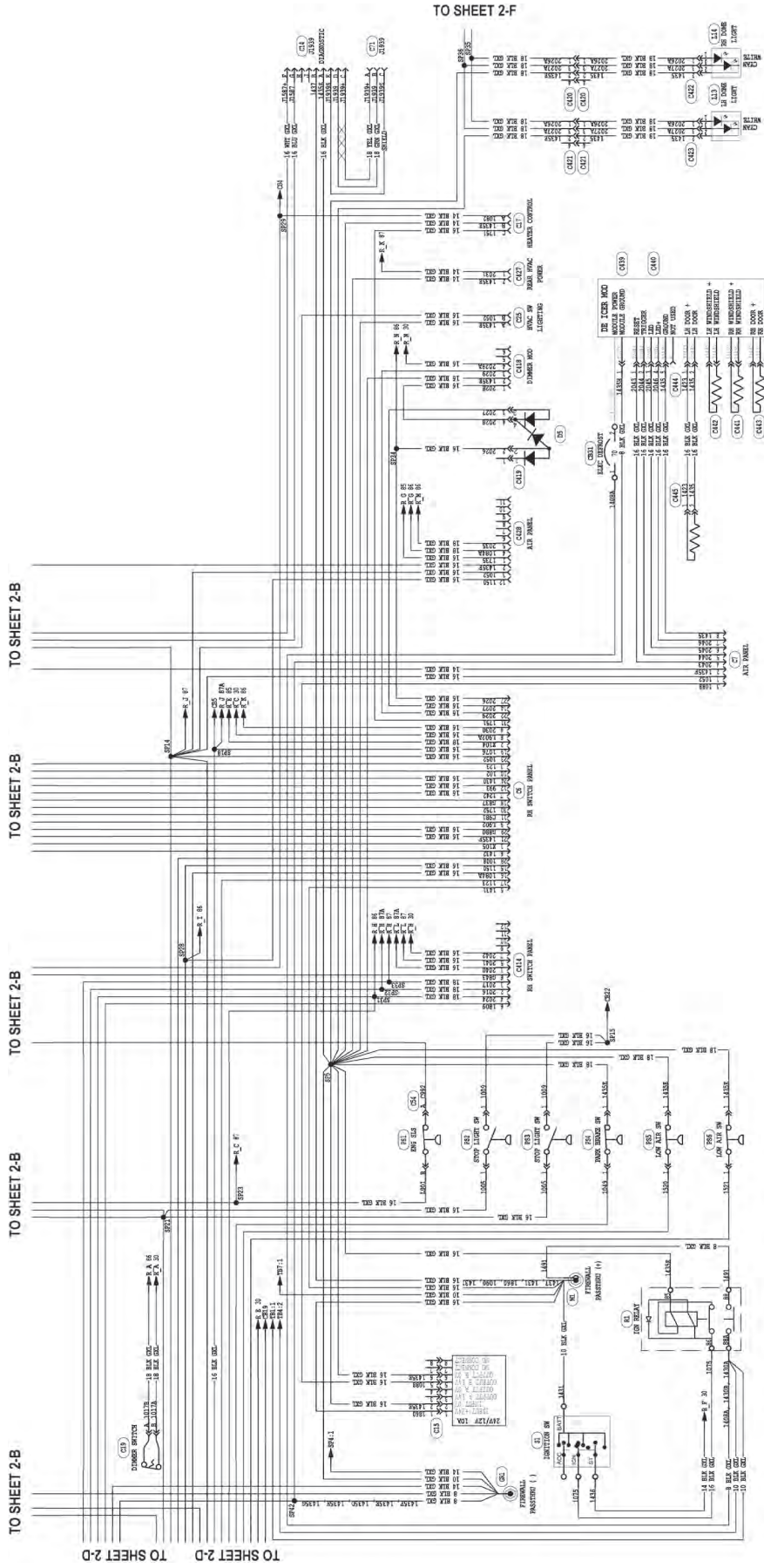

M-ATV ELECTRICAL SCHEMATIC SHEET 2-E (M1240IM1240A1)













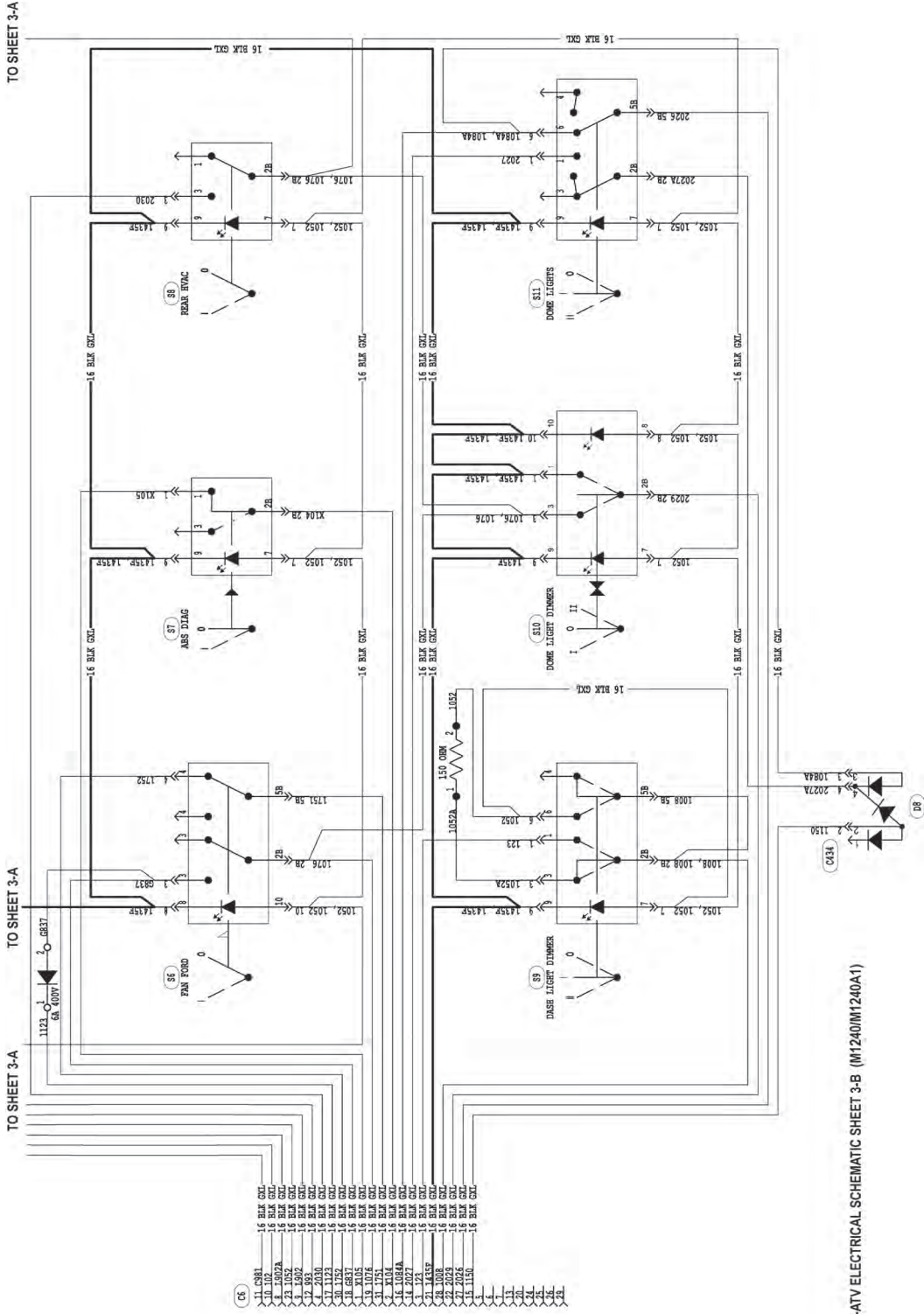

M-ATV ELECTRICAL SCHEMATIC SHEET 3-B (M1240/M1240A1)









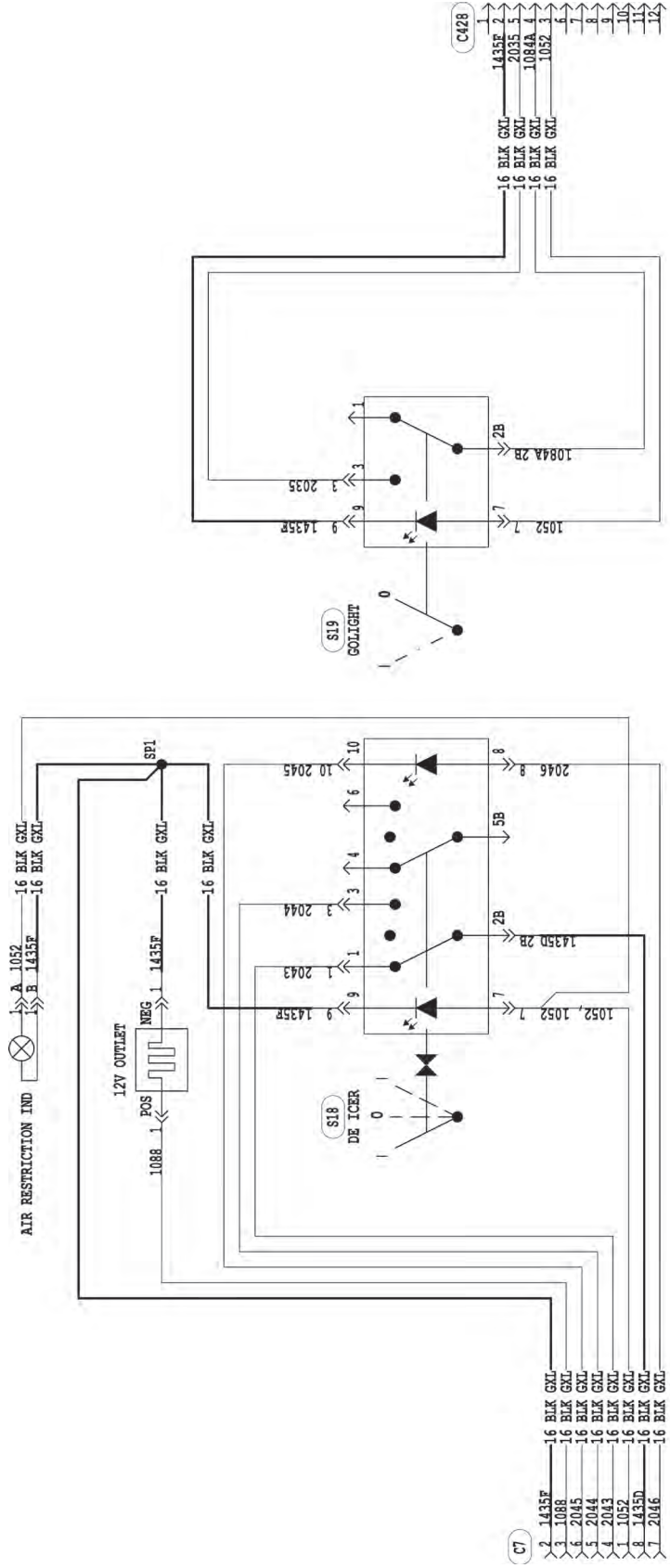

M-ATV ELECTRICAL SCHEMATIC SHEET 3-D (M1240/M1240A1)



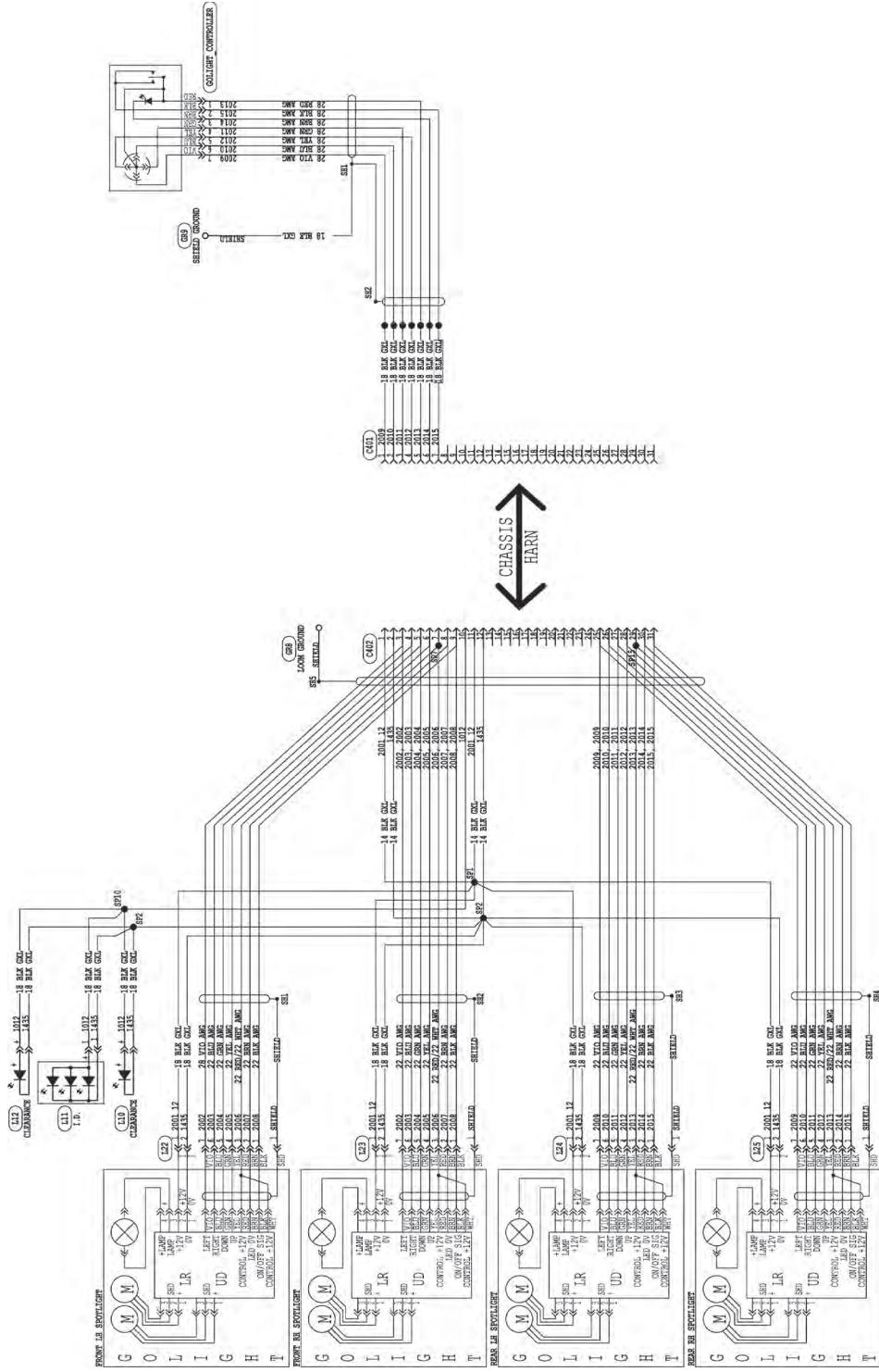

M-ATV ELECTRICAL SCHEMATIC SHEET 4 (M1240/M1240A1)









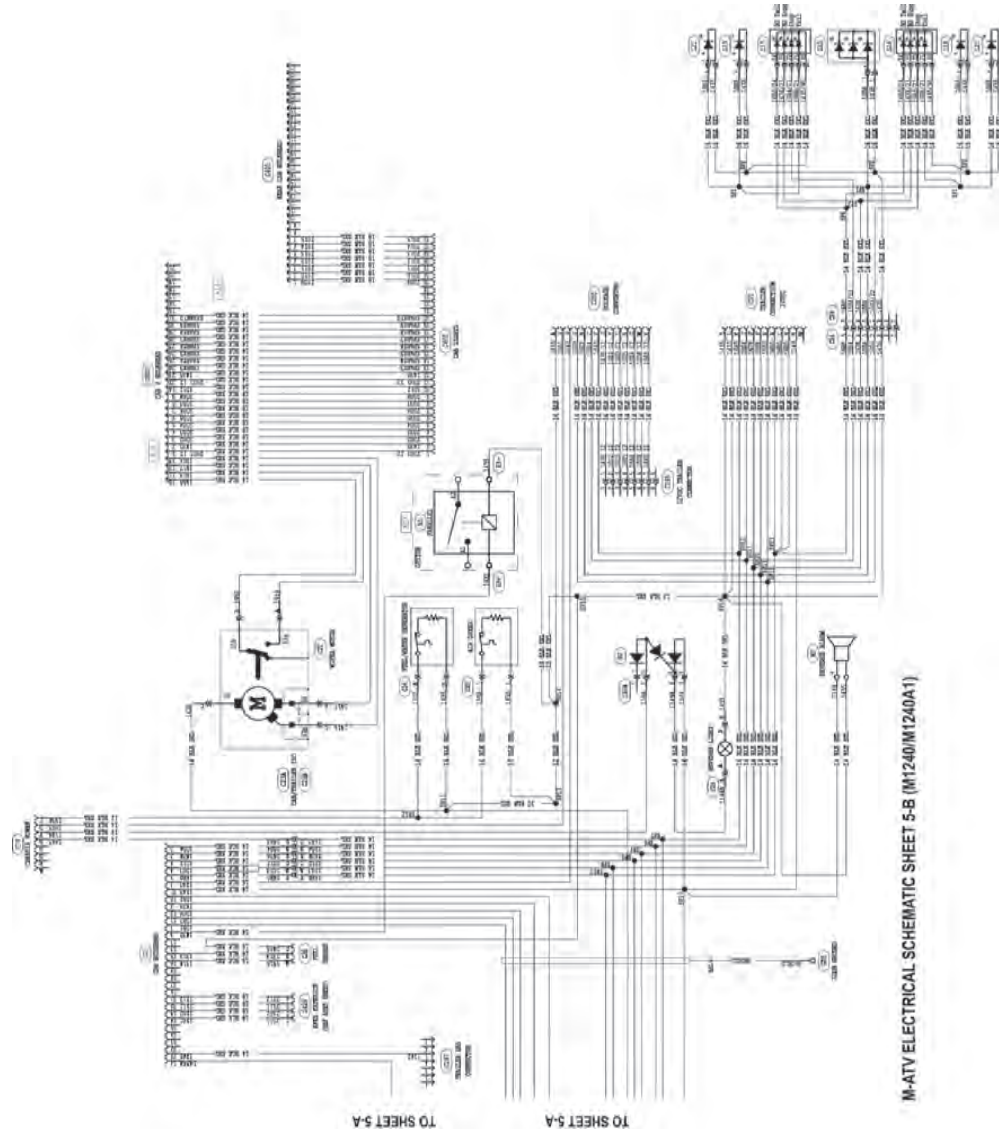



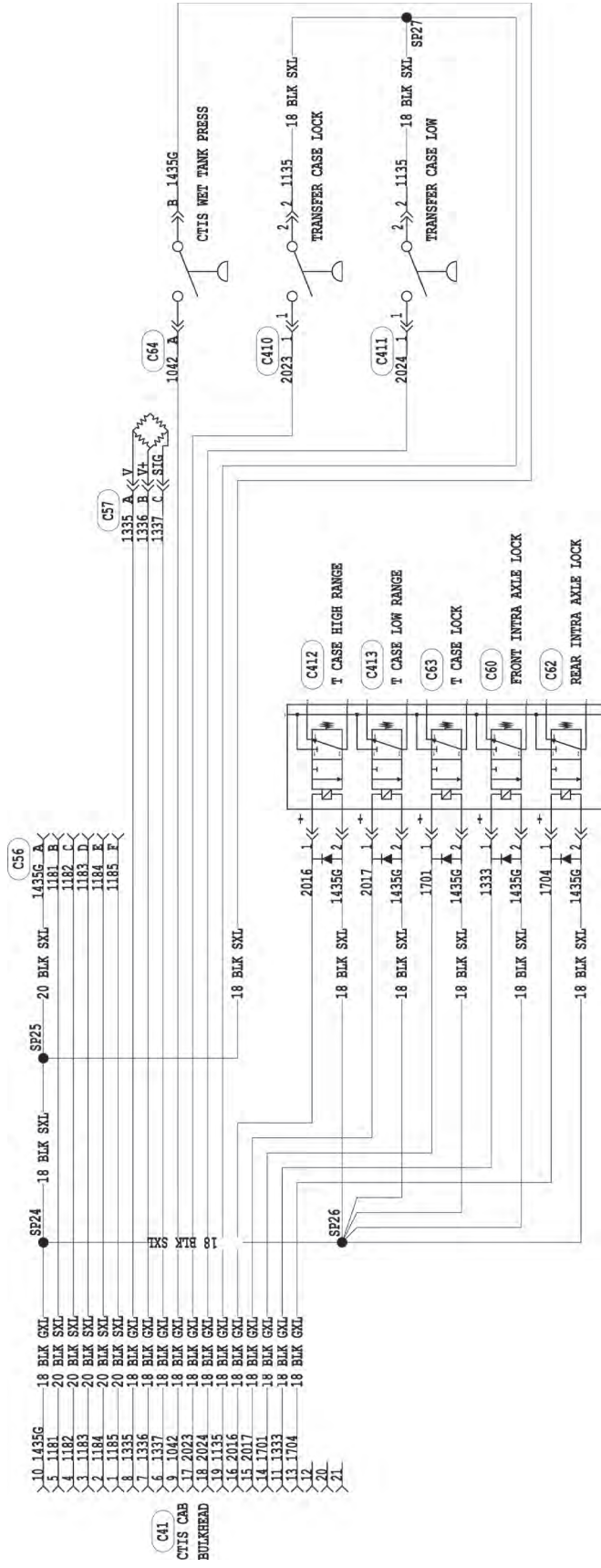

M-ATV ELECTRICAL SCHEMATIC SHEET 5-C (M1240/M1240A1)



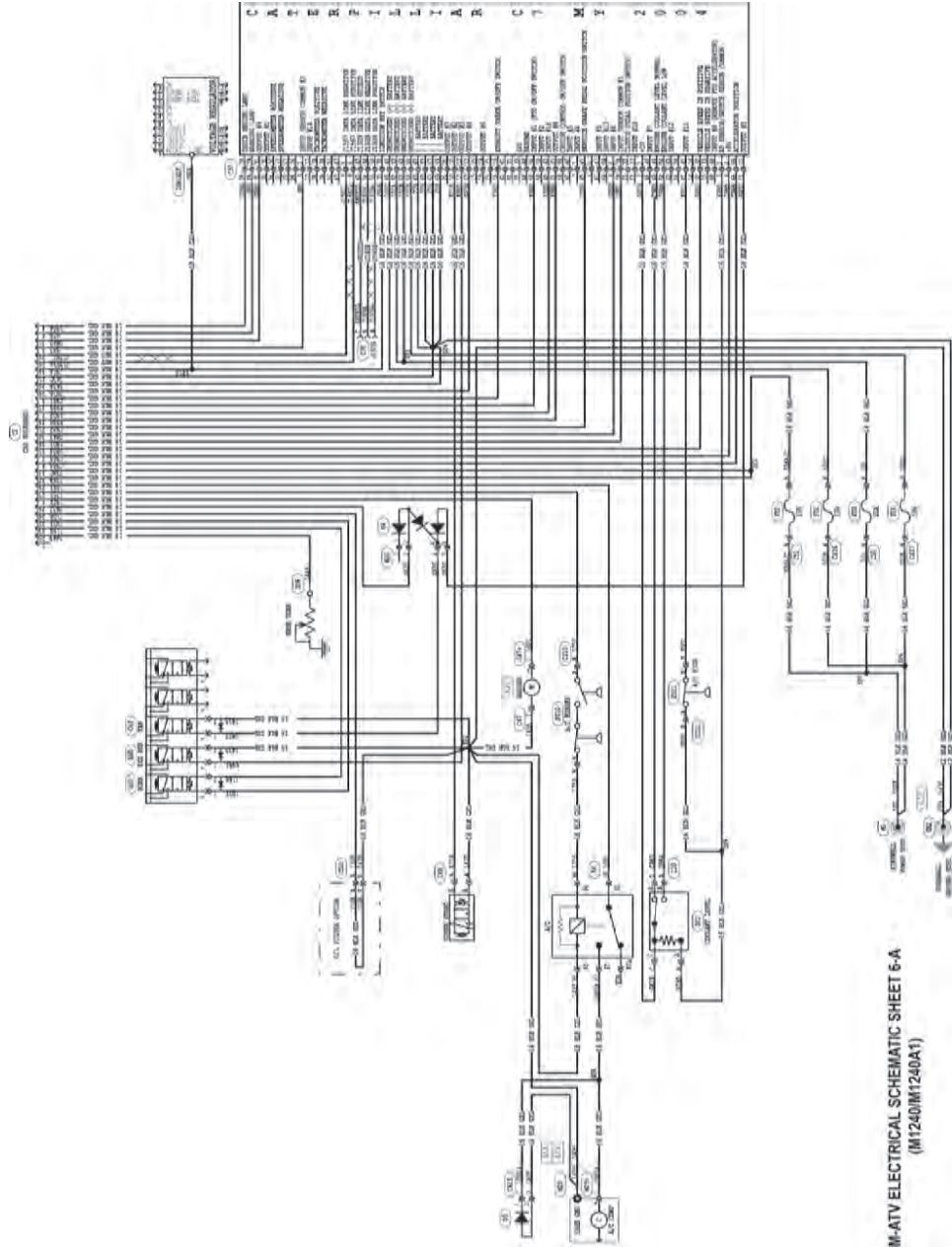





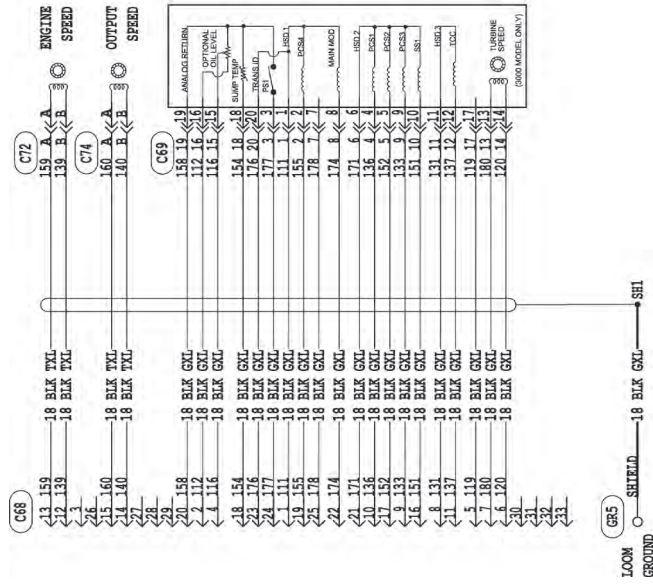

M-ATV ELECTRICAL SCHEMATIC SHEET 6-B (M1240/M1240A1)

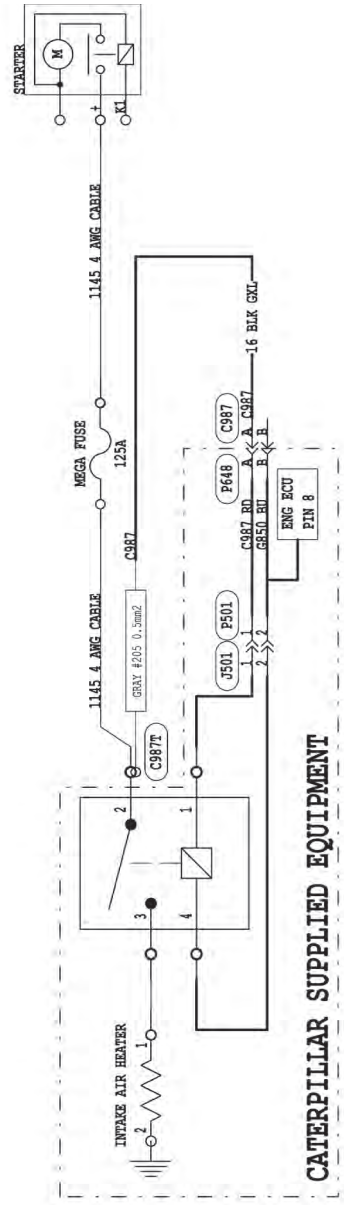



# ANTI-LOCK BRAKING SYSTEM GENERATION 4

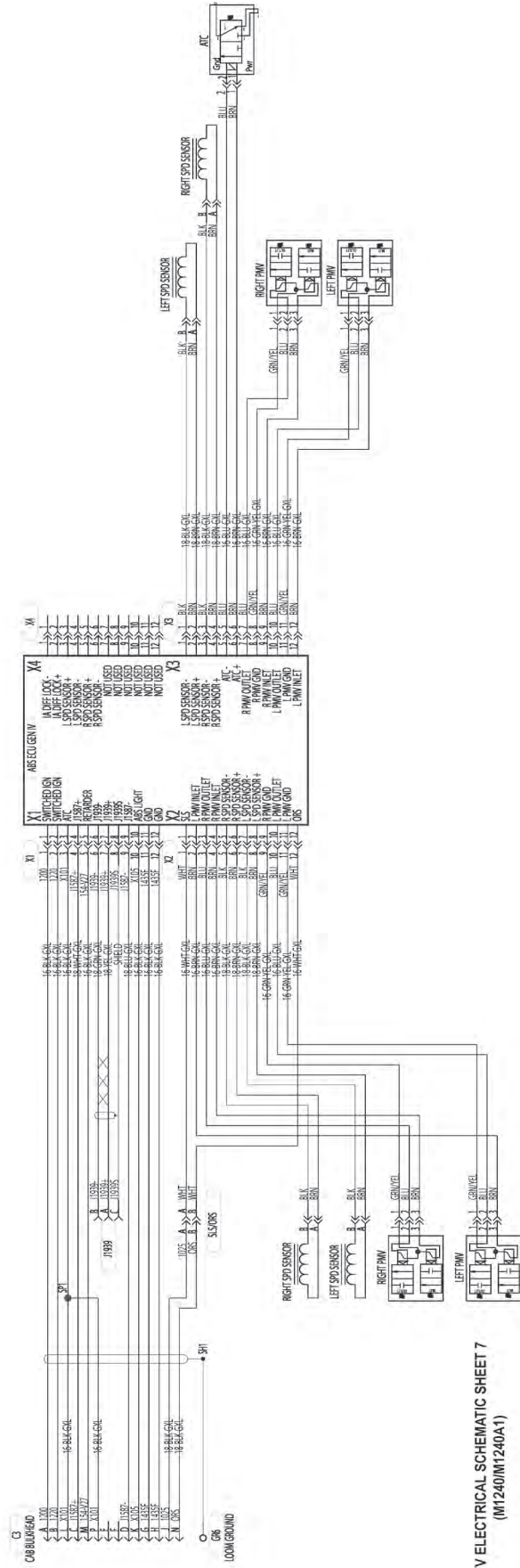

M-ATV ELECTRICAL SCHEMATIC SHEET 7  
(M1240/M1240A1)



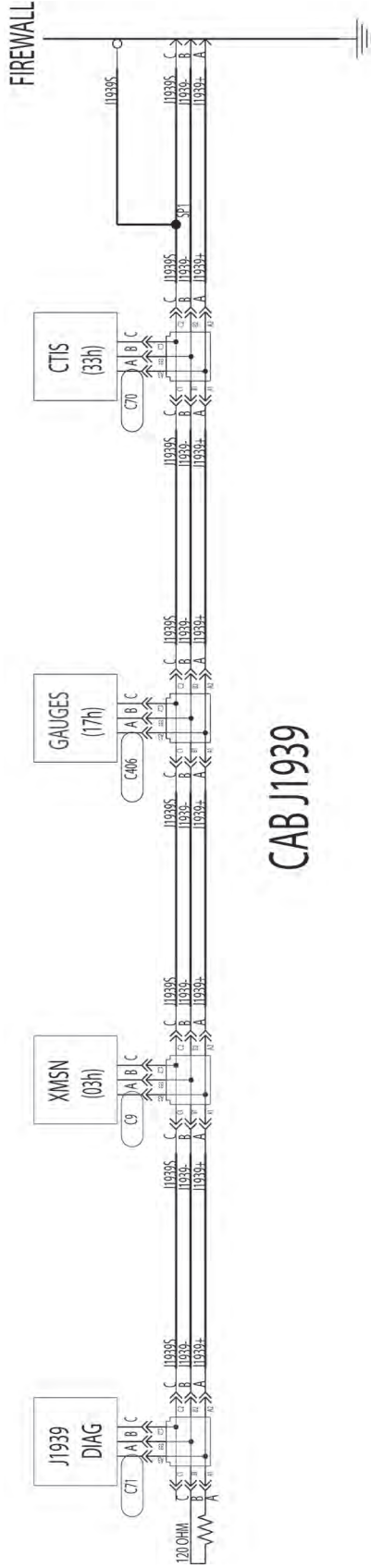

### CAB J1939

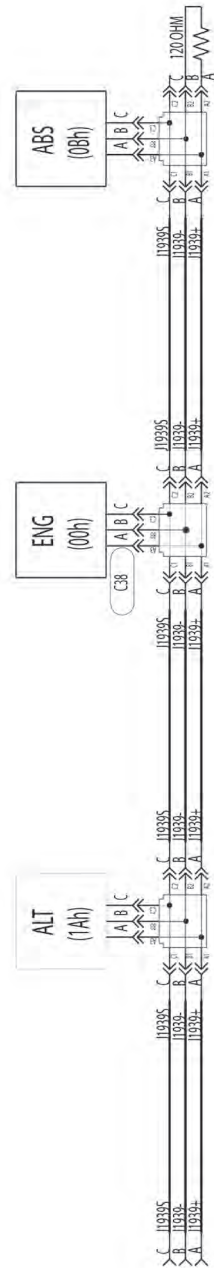

### CHASSIS J1939

M-ATV ELECTRICAL SCHEMATIC SHEET 8 (M1240/M1240A1)



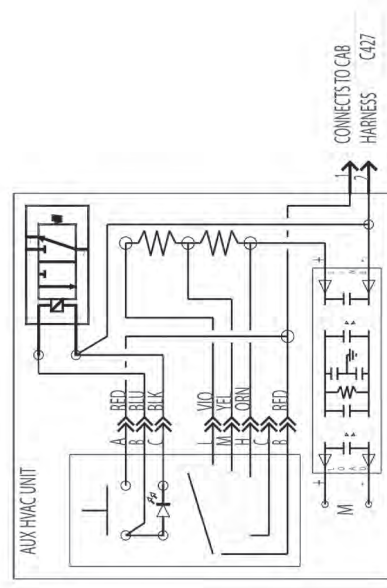
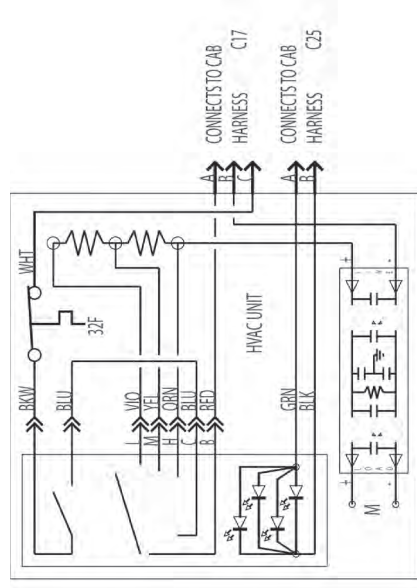

M-ATV ELECTRICAL SCHEMATIC SHEET 9 (M1240/M1240A1)





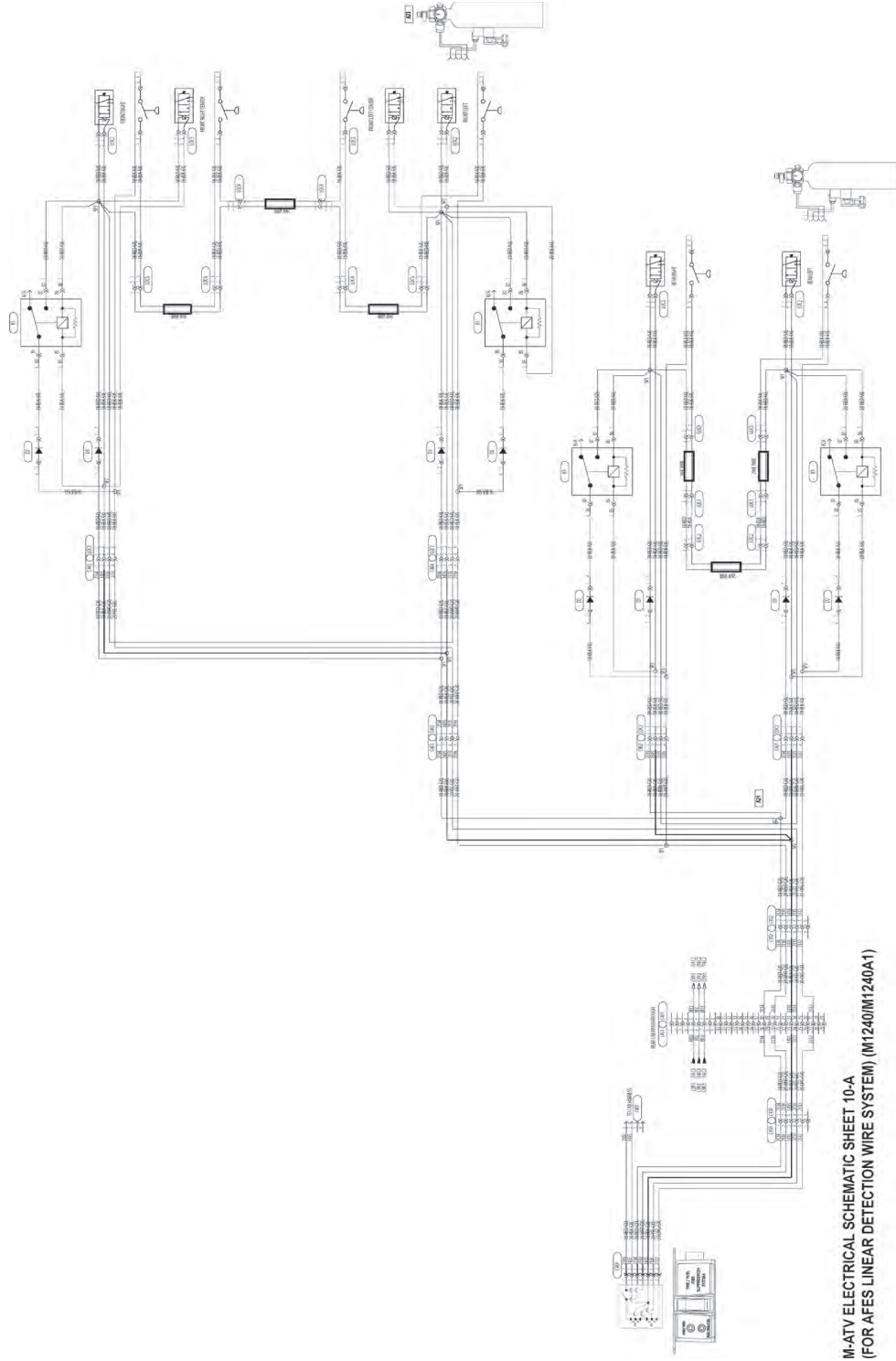

M-ATV ELECTRICAL SCHEMATIC SHEET 10-A  
(FOR AFES LINEAR DETECTION WIRE SYSTEM) (M1240/M1240A1)



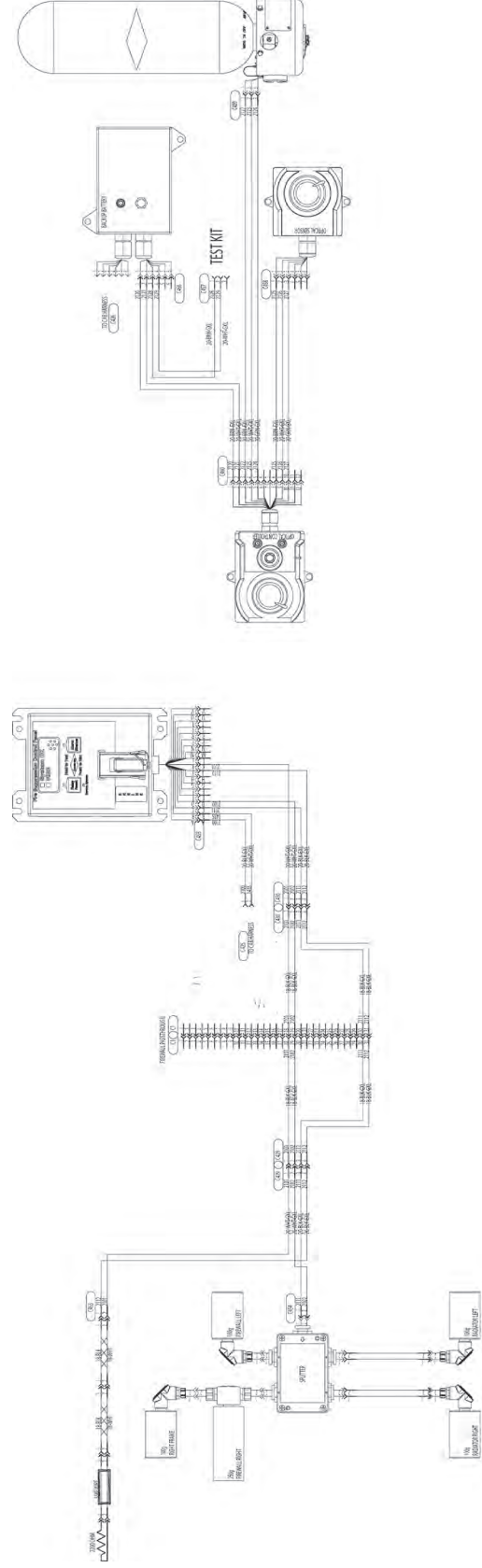

M-ATV ELECTRICAL SCHEMATIC SHEET 10-B (FOR FIVE AEROSOL GENERATOR SYSTEM) (M1240IM1240A1)



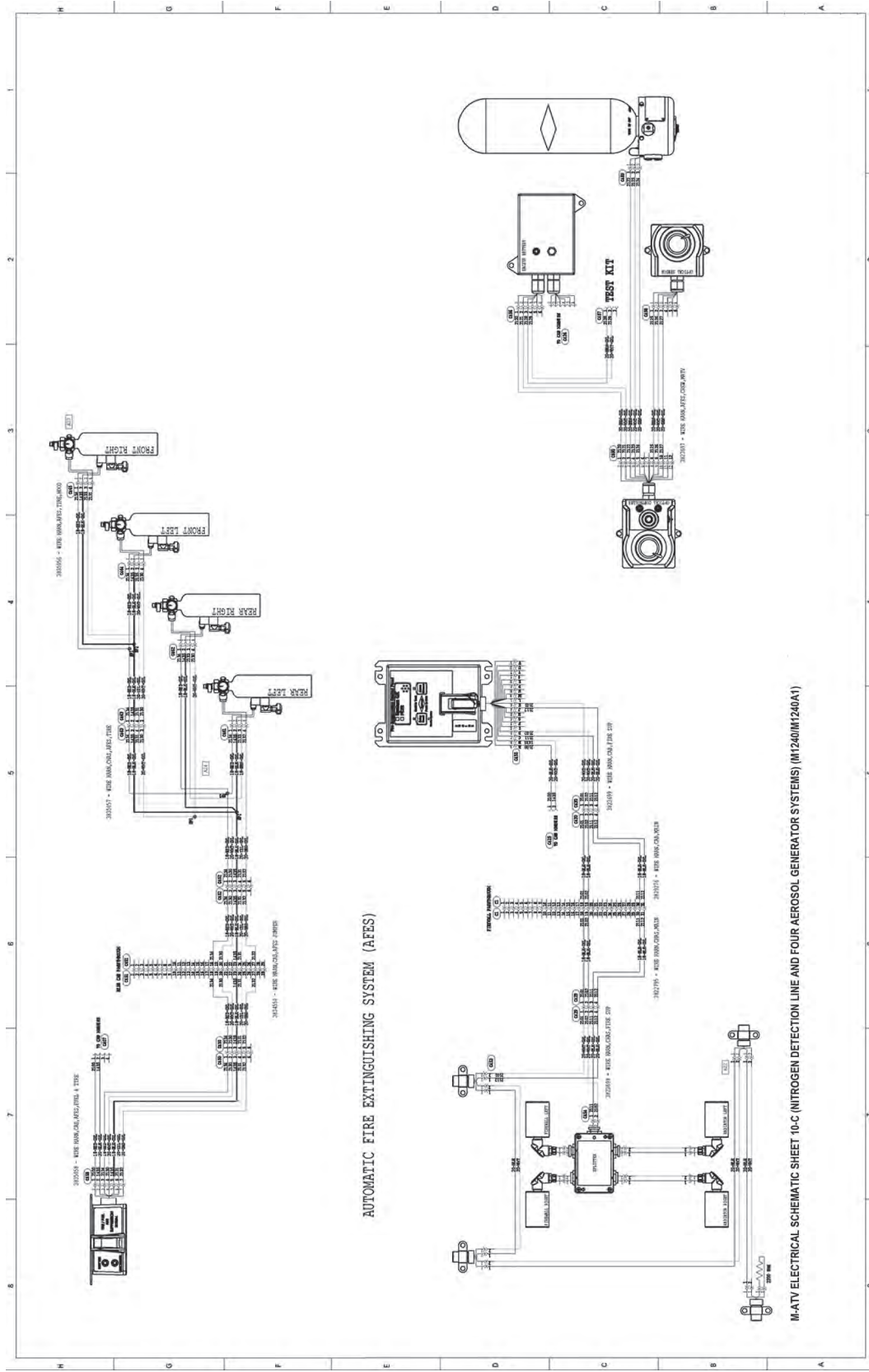

AUTOMATIC FIRE EXTINGUISHING SYSTEM (AFES)

M-ATV ELECTRICAL SCHEMATIC SHEET 10-C (NITROGEN DETECTION LINE AND FOUR AEROSOL GENERATOR SYSTEMS) (M1240/M1240A1)





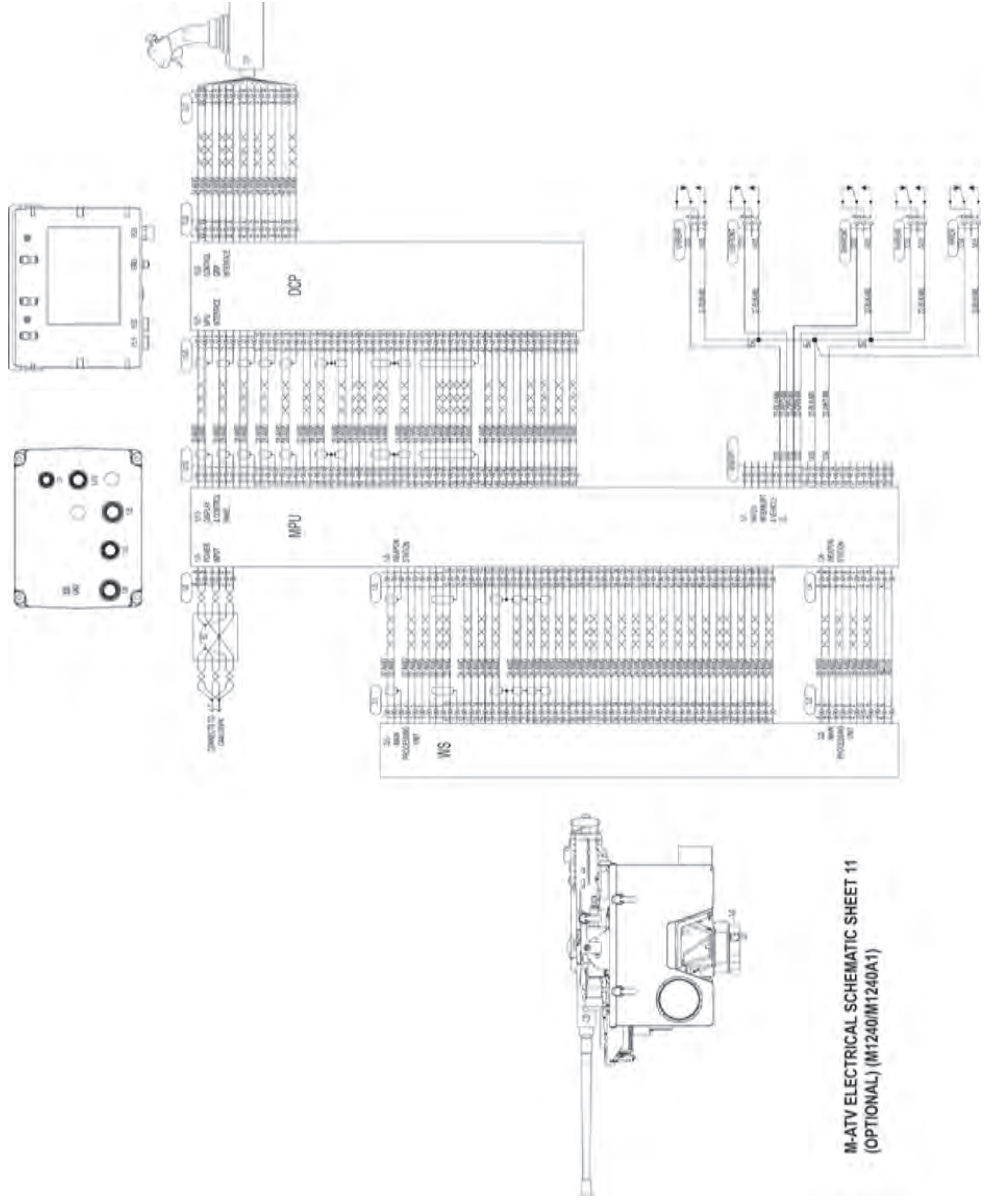

M-ATV ELECTRICAL SCHEMATIC SHEET 11  
(OPTIONAL) (M1240/M1240A1)



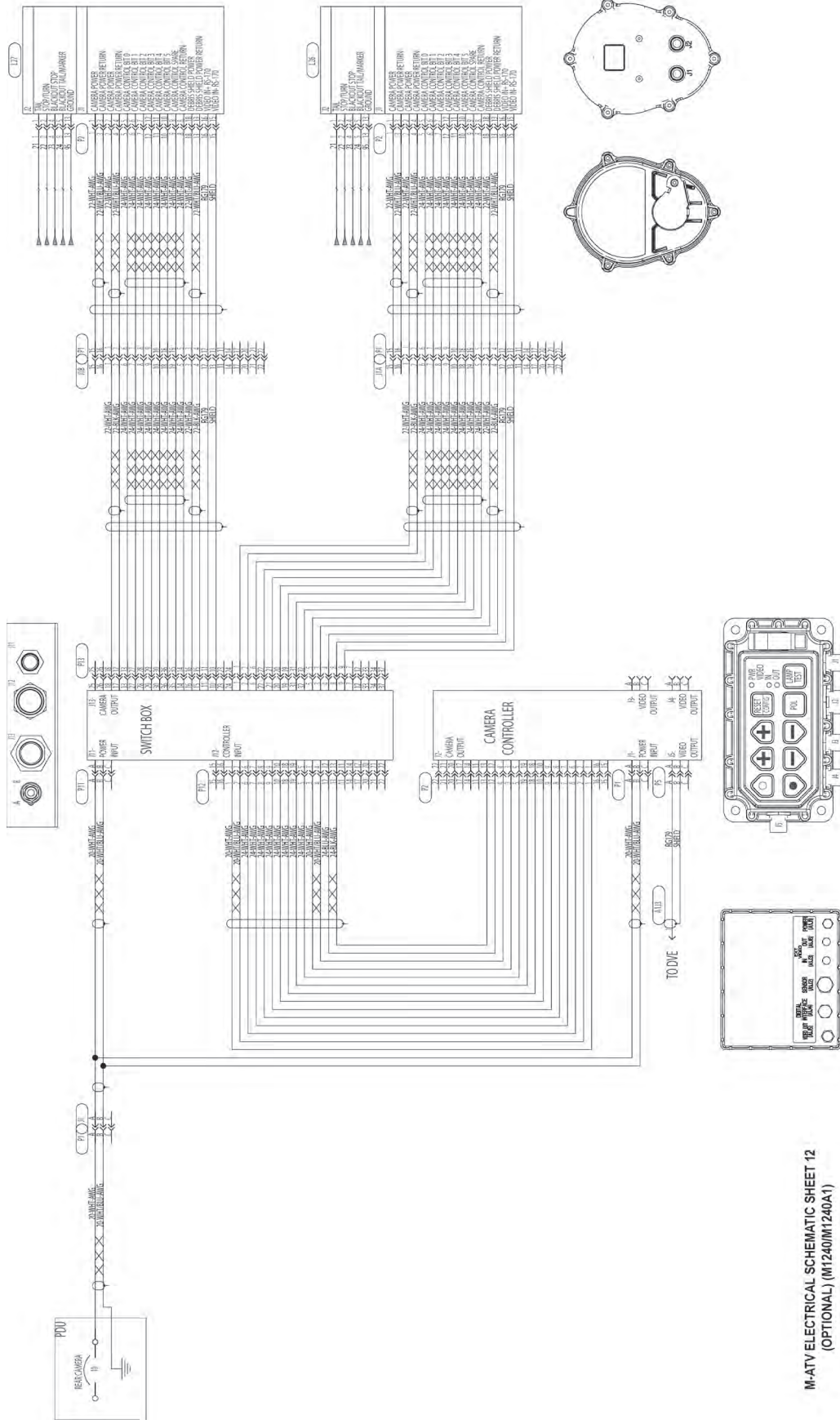

M-ATV ELECTRICAL SCHEMATIC SHEET 12 (OPTIONAL) (M1240/M1240A1)



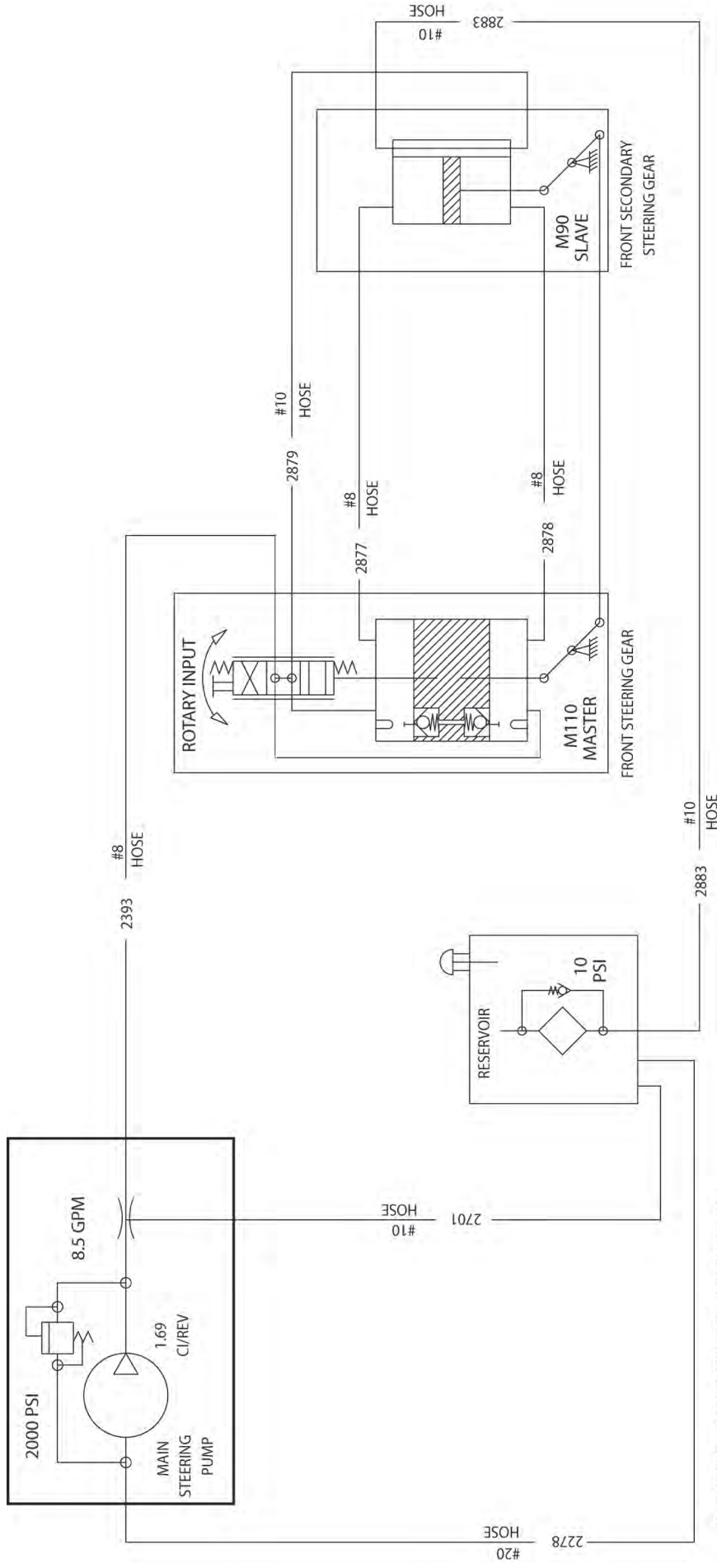

M-ATV HYDRAULIC SCHEMATIC SHEET 13 (M1240/M1240A1)



---

SCHEMATICS FOR M-ATV-M1245

---

**CAUTION**

Schematics contained in this section are for M-ATV M1245. Do not use these schematics for any other model. Failure to comply may result in damage to equipment.





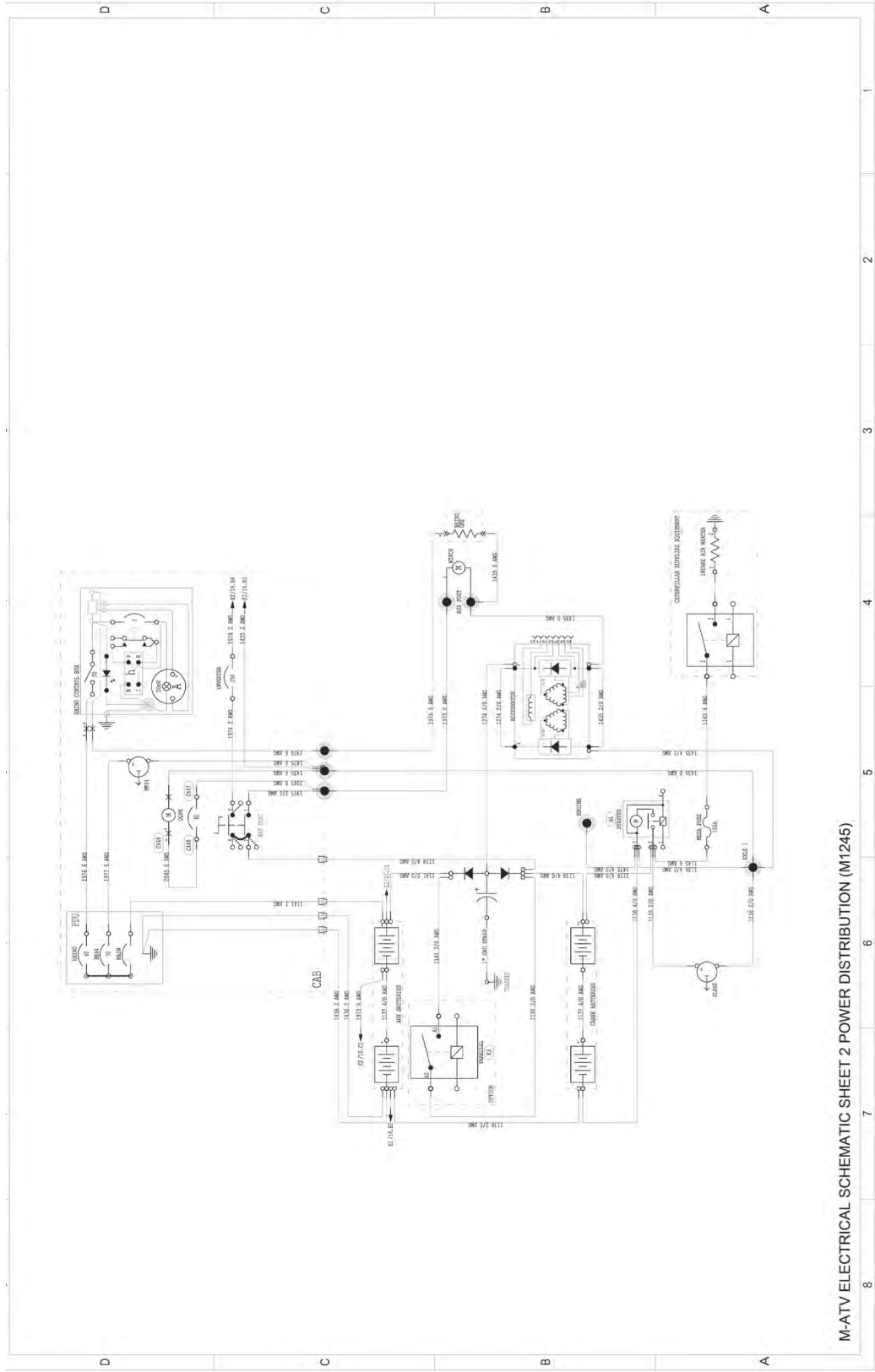

M-ATV ELECTRICAL SCHEMATIC SHEET 2 POWER DISTRIBUTION (M1245)



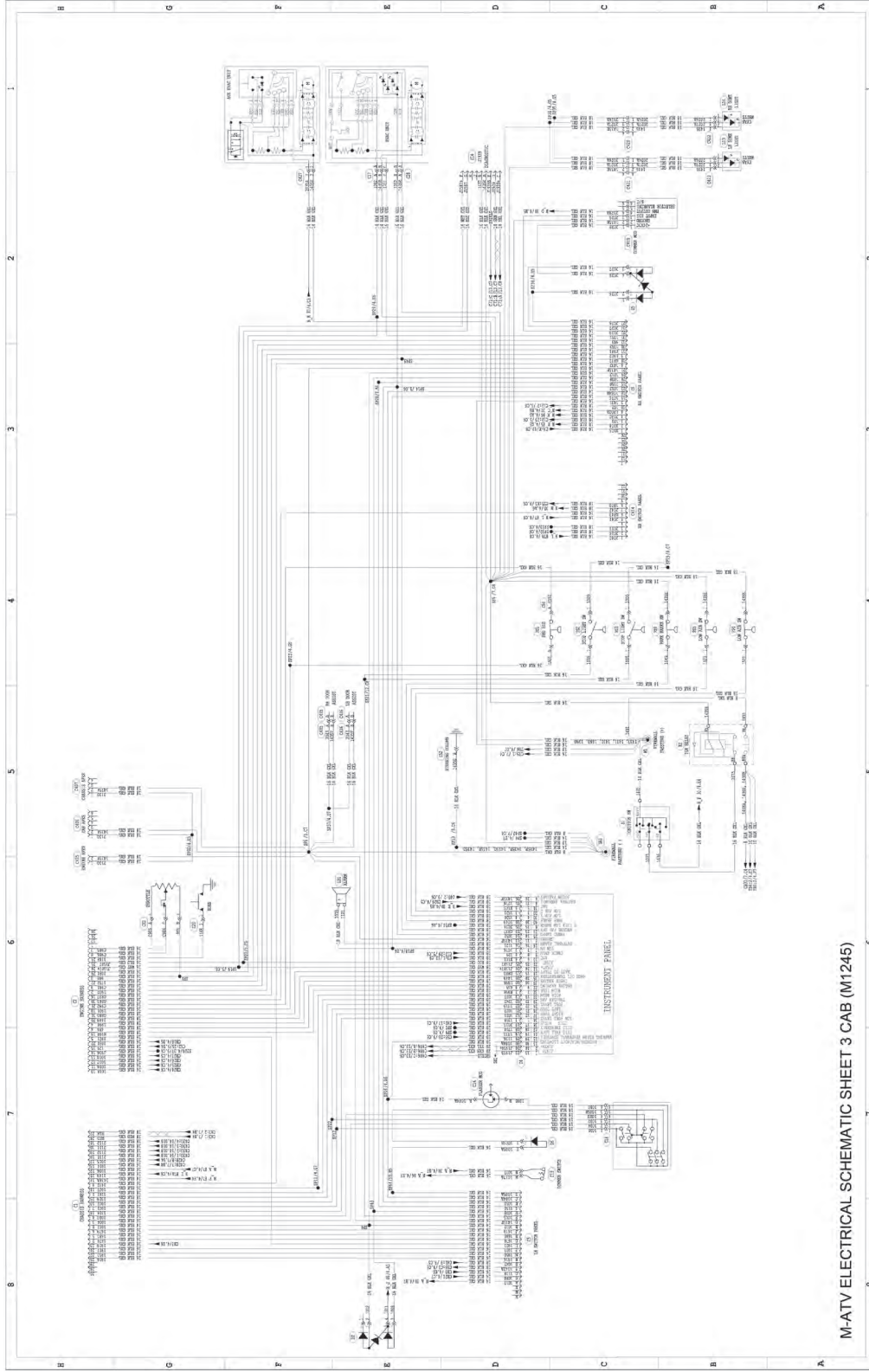

M-ATV ELECTRICAL SCHEMATIC SHEET 3 CAB (M1245)



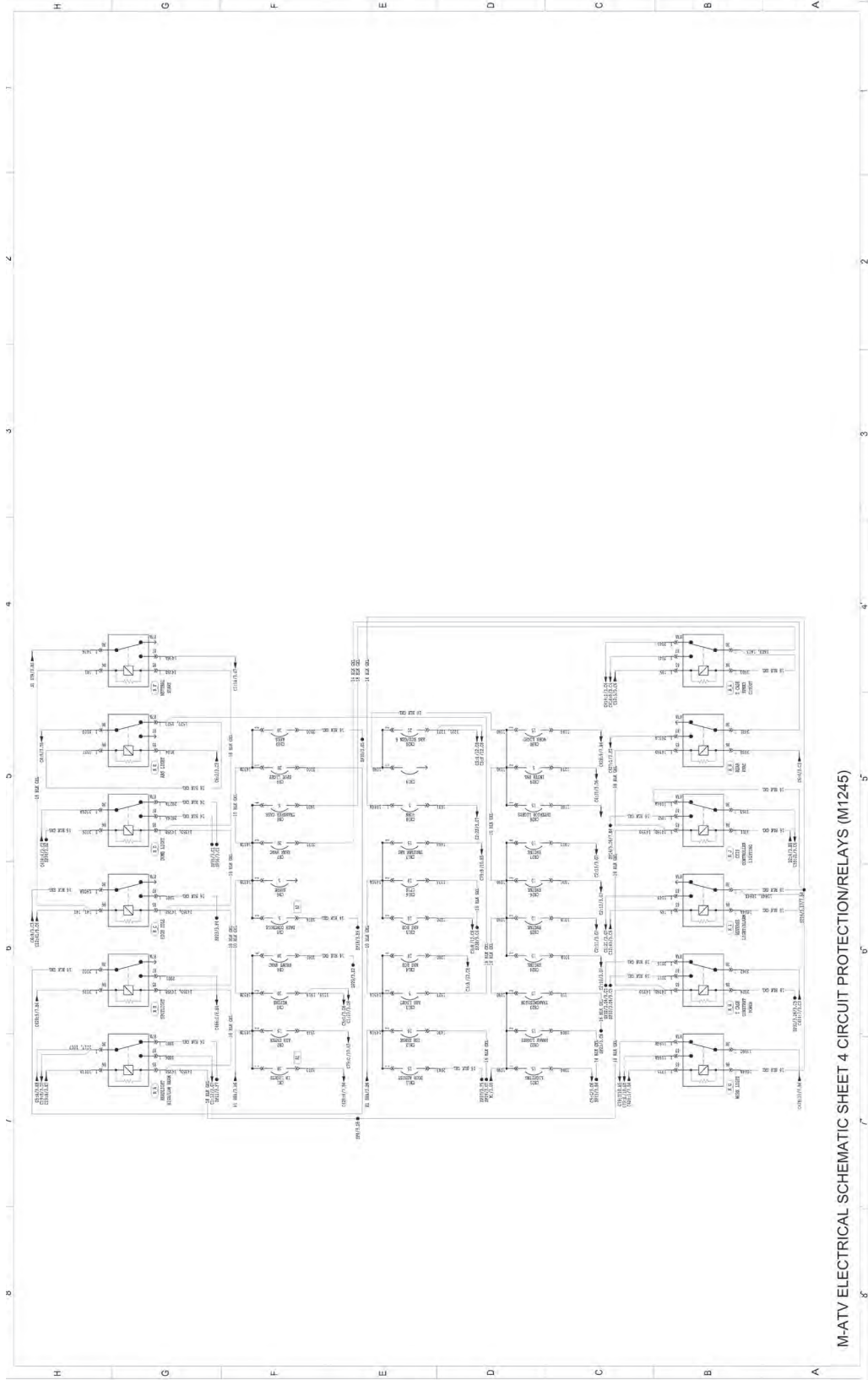

M-ATV ELECTRICAL SCHEMATIC SHEET 4 CIRCUIT PROTECTION/RELAYS (M1245)





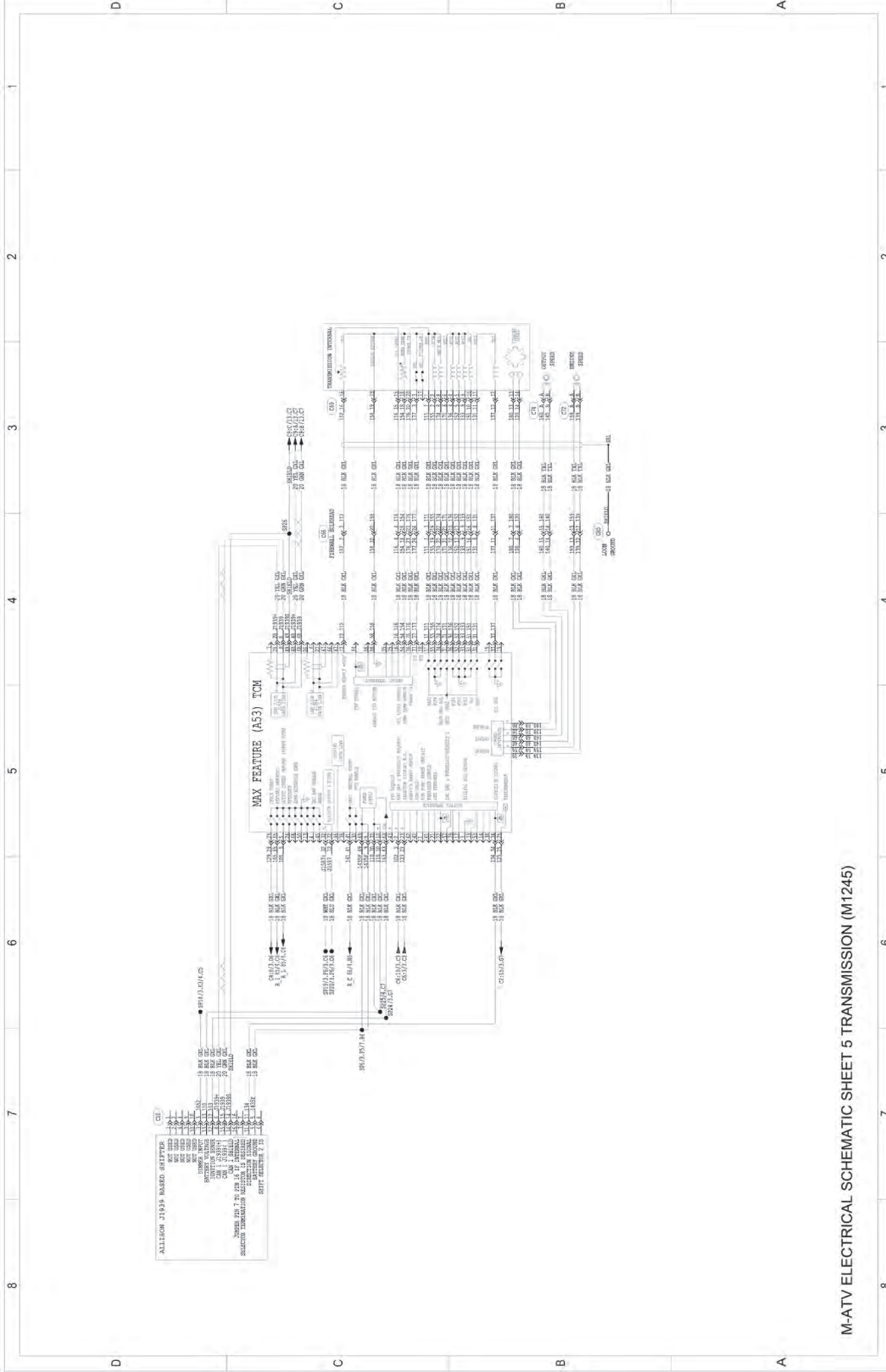

M-ATV ELECTRICAL SCHEMATIC SHEET 5 TRANSMISSION (M1245)



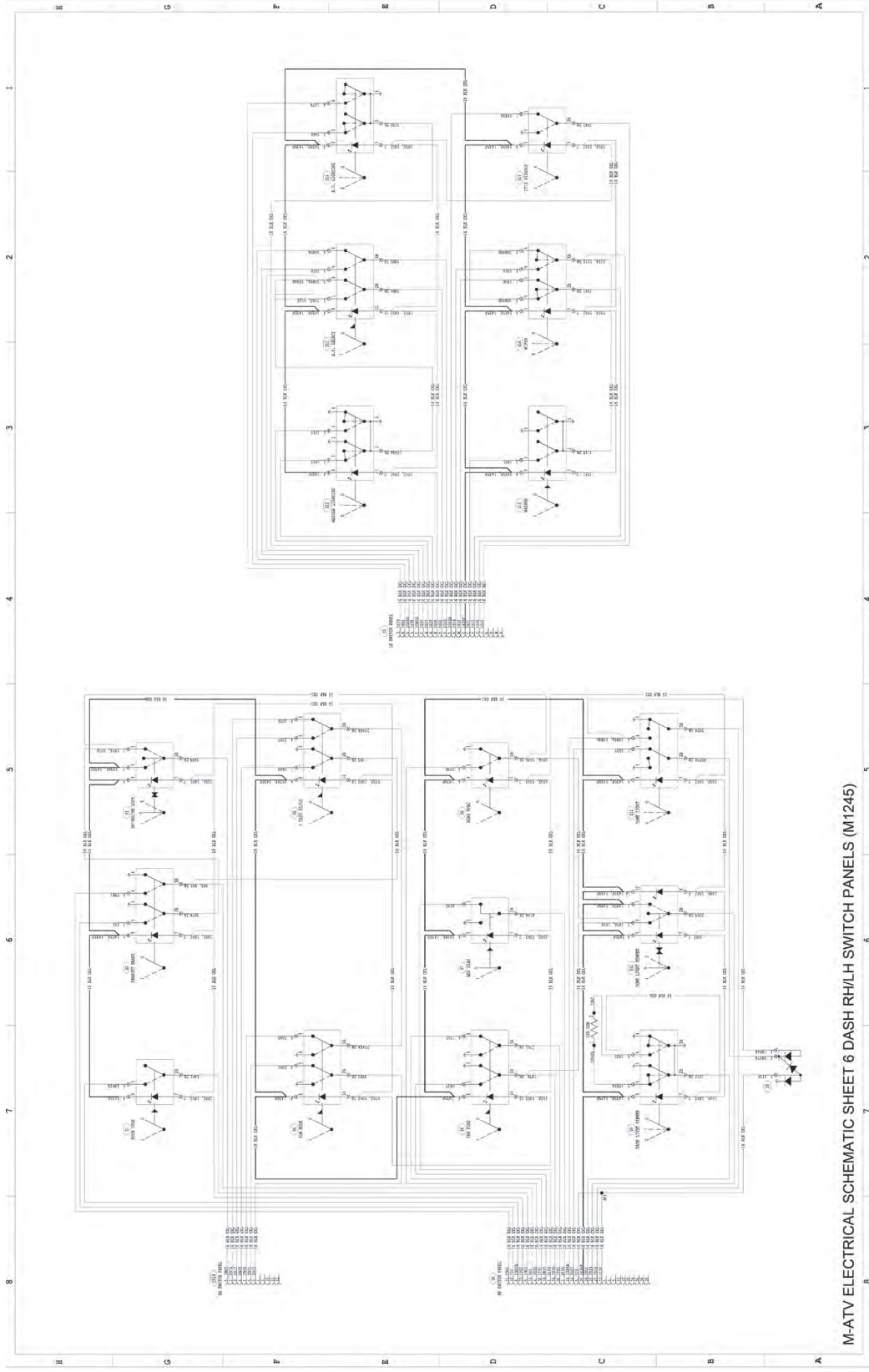



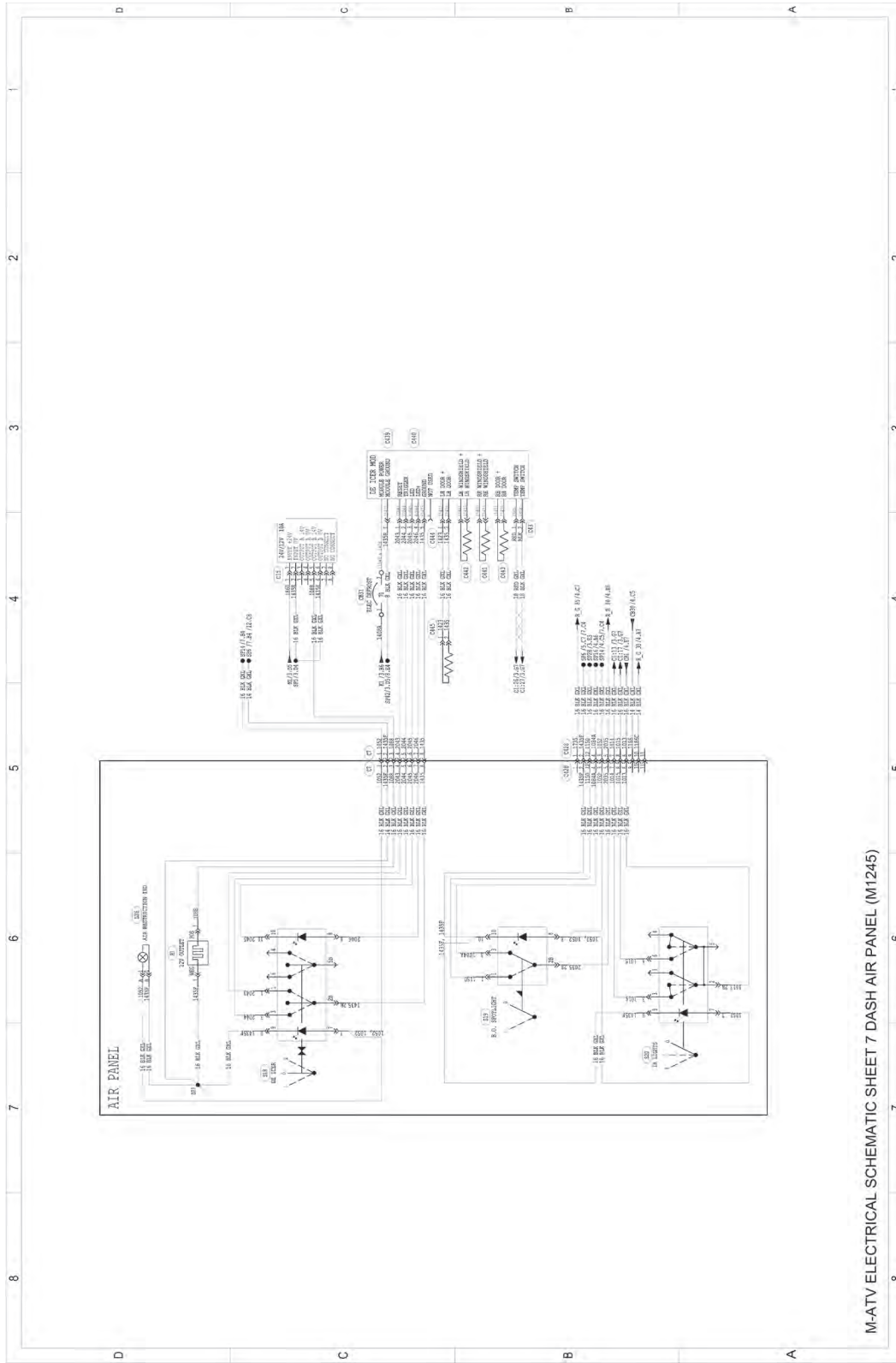

M-ATV ELECTRICAL SCHEMATIC SHEET 7 DASH AIR PANEL (M1245)



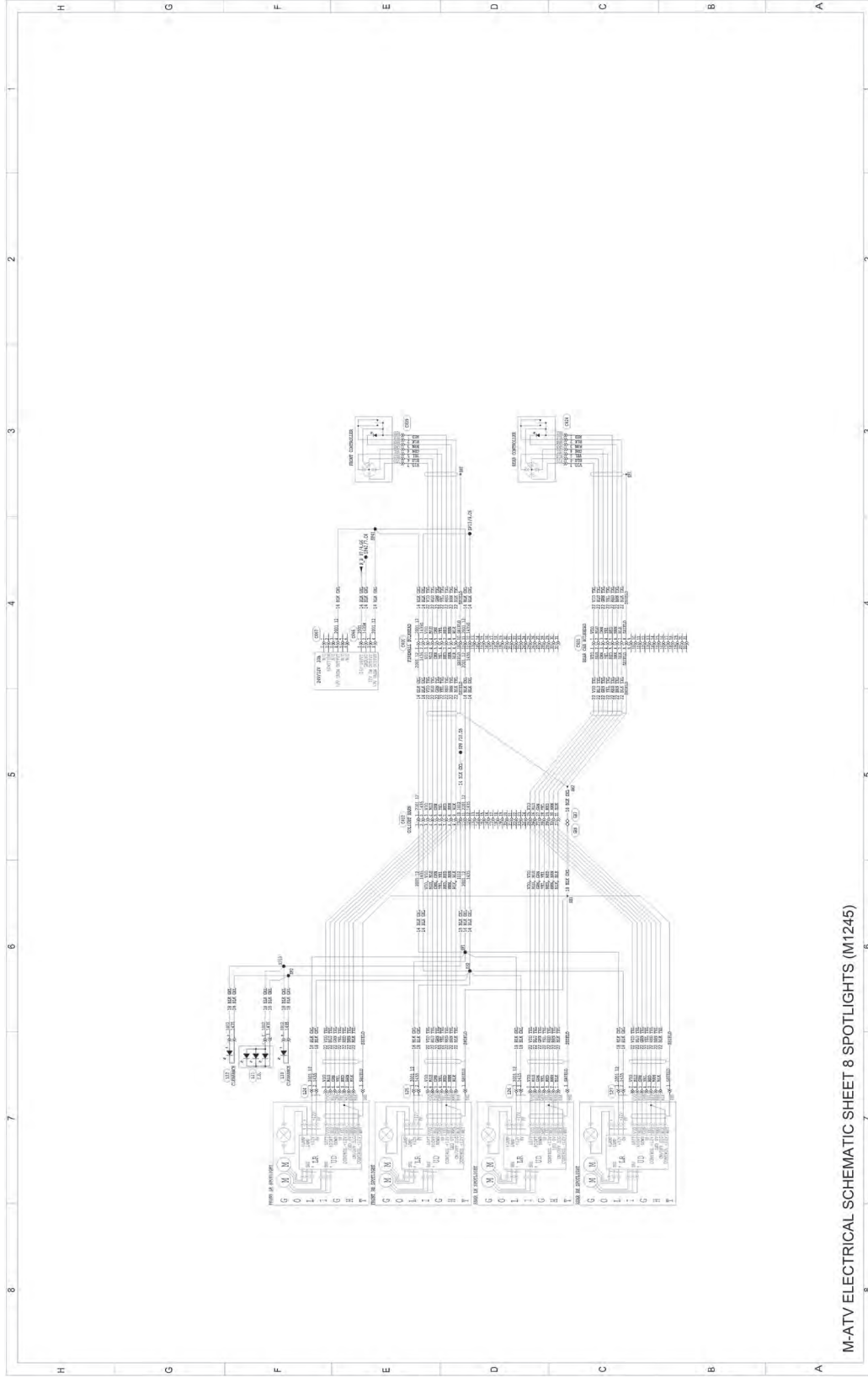

M-ATV ELECTRICAL SCHEMATIC SHEET 8 SPOTLIGHTS (M1245)





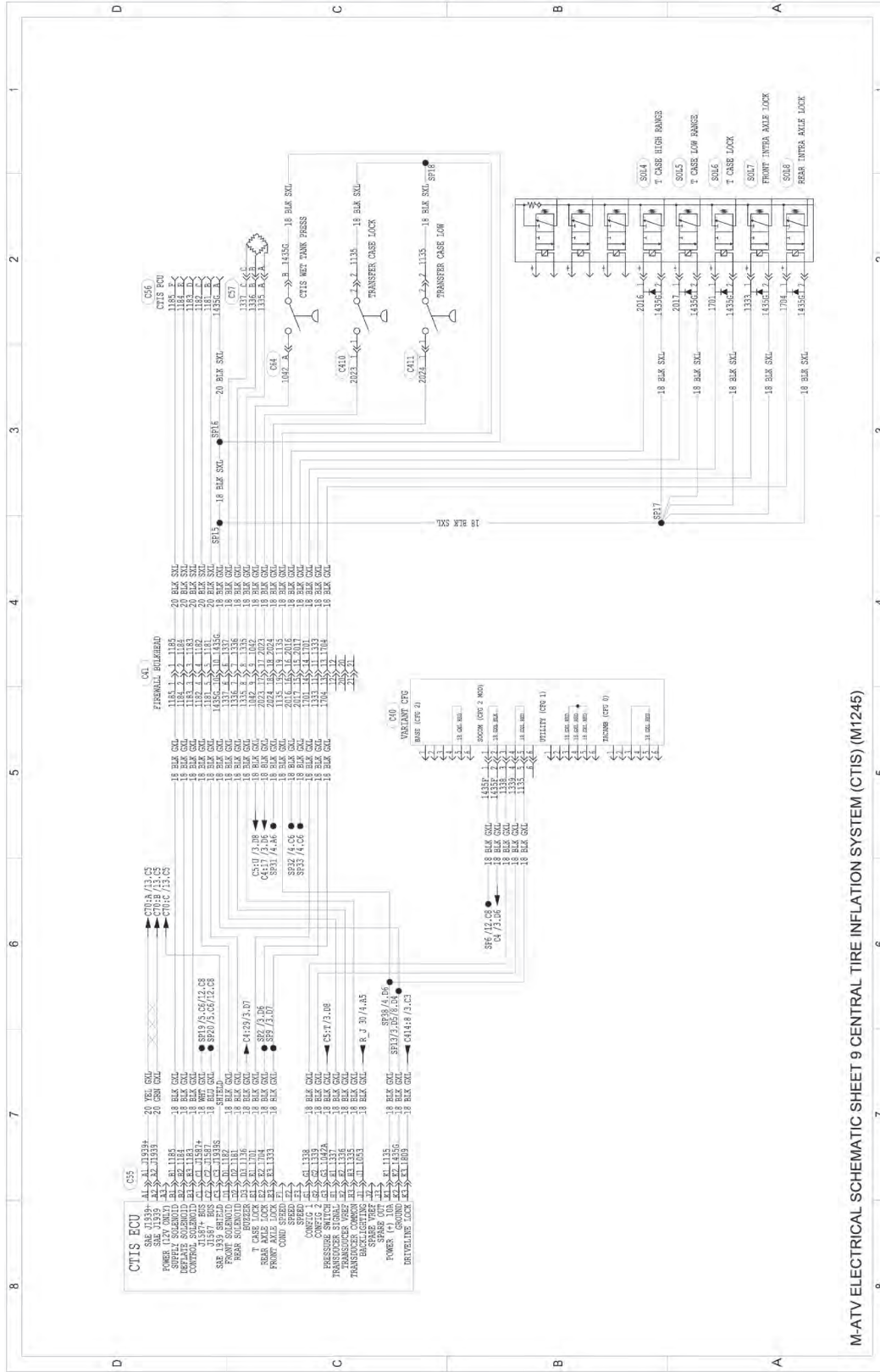

M-ATV ELECTRICAL SCHEMATIC SHEET 9 CENTRAL TIRE INFLATION SYSTEM (CTIS) (M1245)





M-ATV ELECTRICAL SCHEMATIC SHEET 10 CHASSIS (M1245)



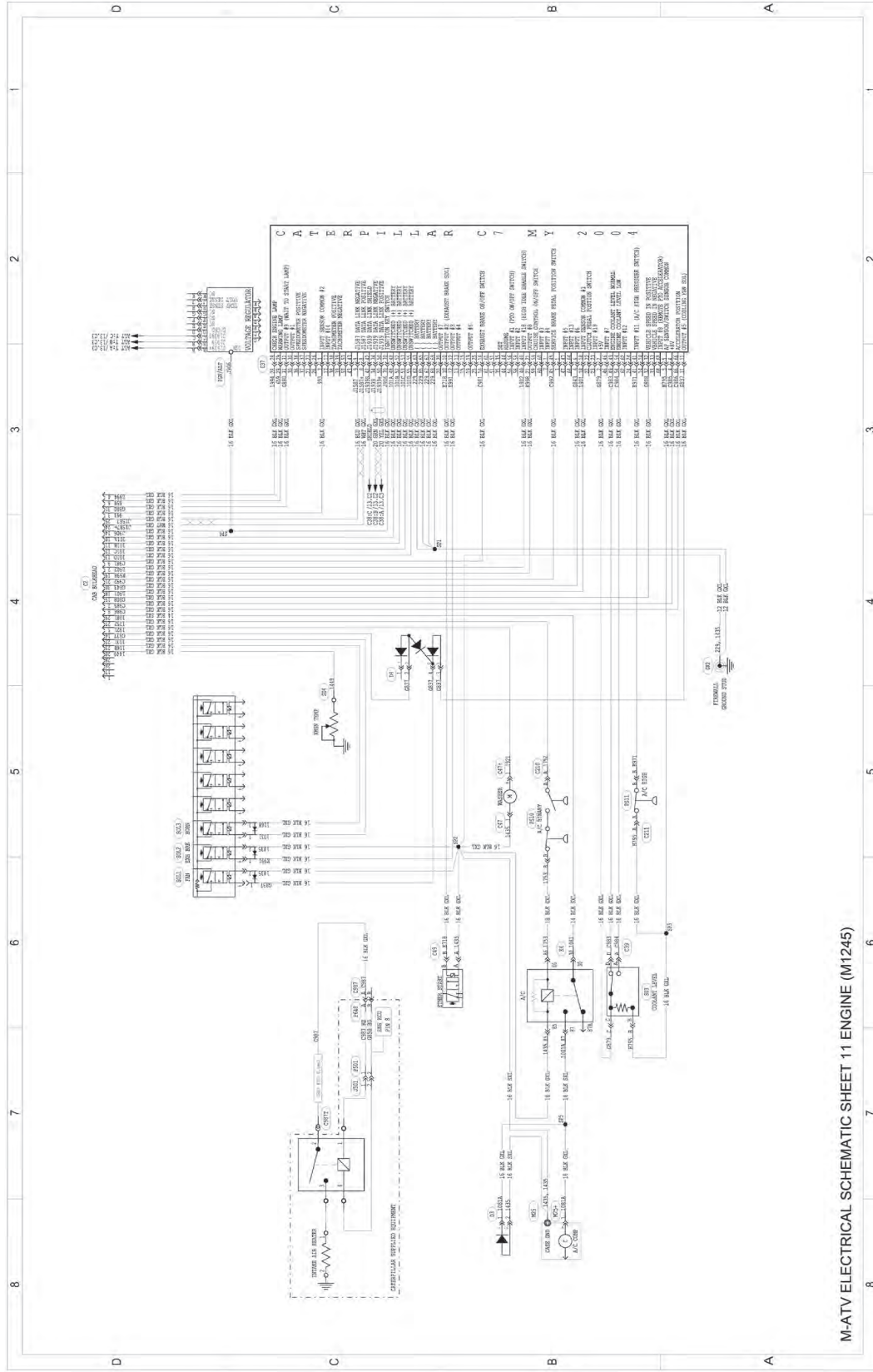

M-ATV ELECTRICAL SCHEMATIC SHEET 11 ENGINE (M1245)





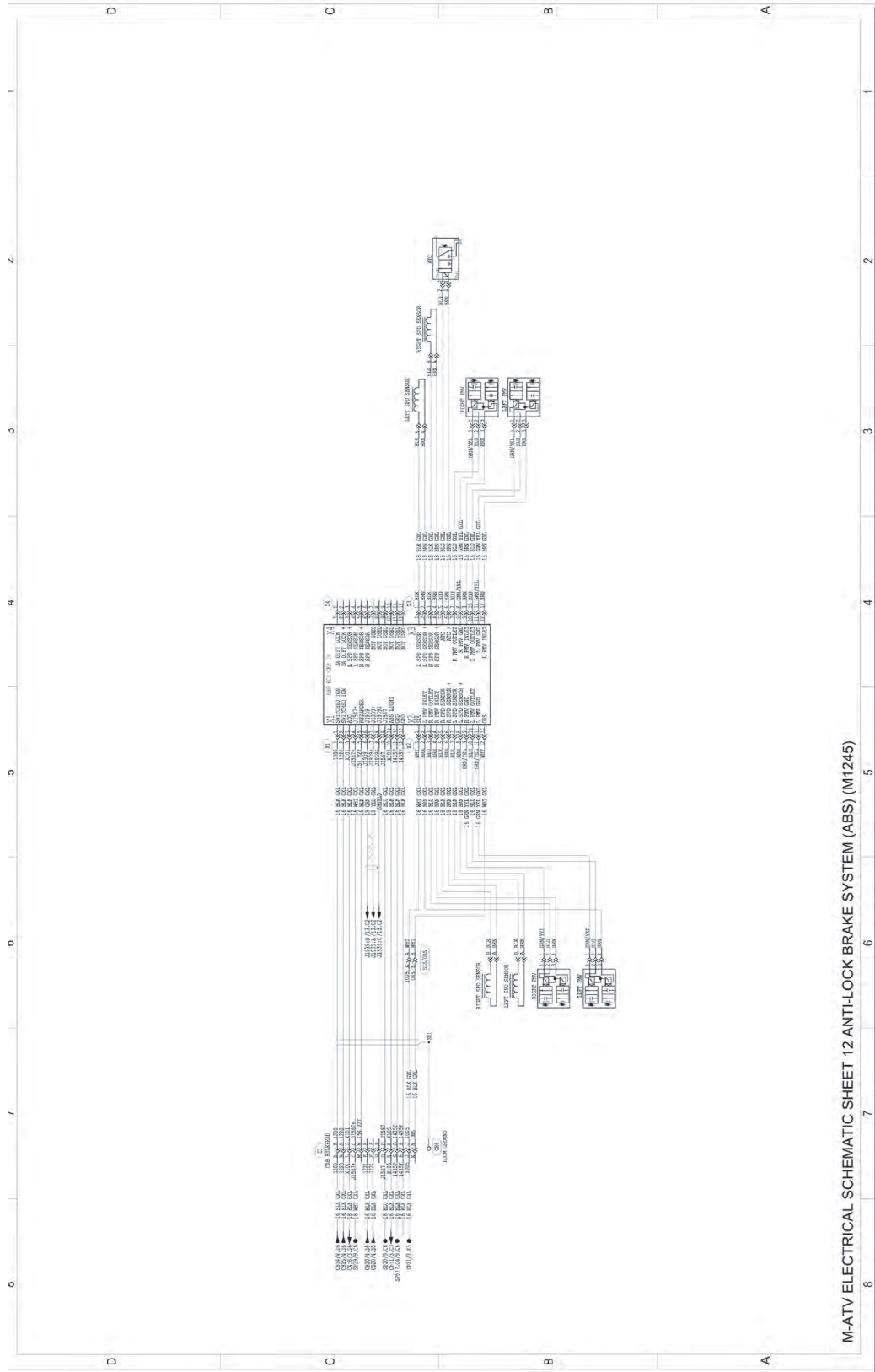

M-ATV ELECTRICAL SCHEMATIC SHEET 12 ANTI-LOCK BRAKE SYSTEM (ABS) (M1245)



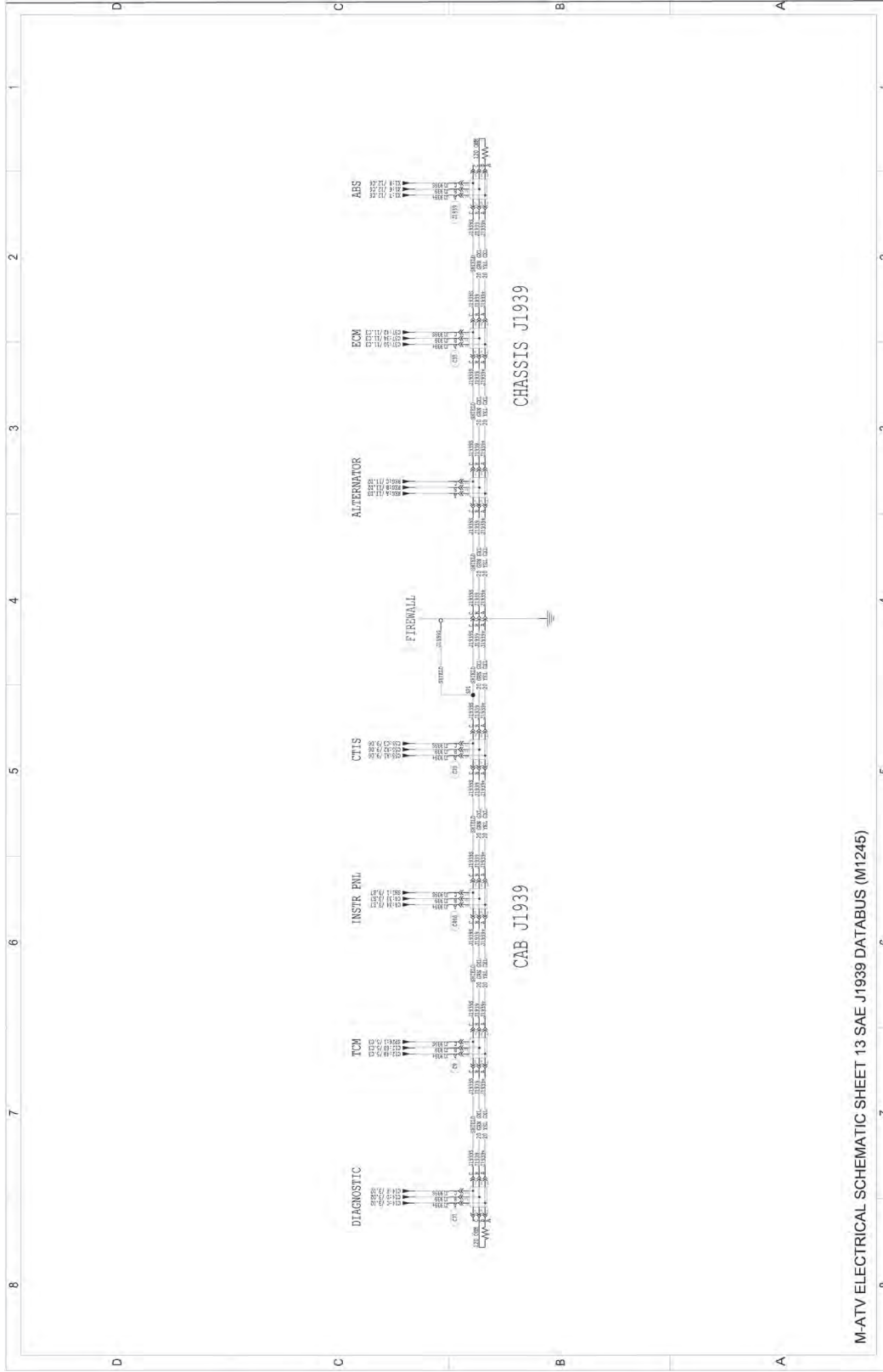

M-ATV ELECTRICAL SCHEMATIC SHEET 13 SAE J1939 DATABUS (M1245)



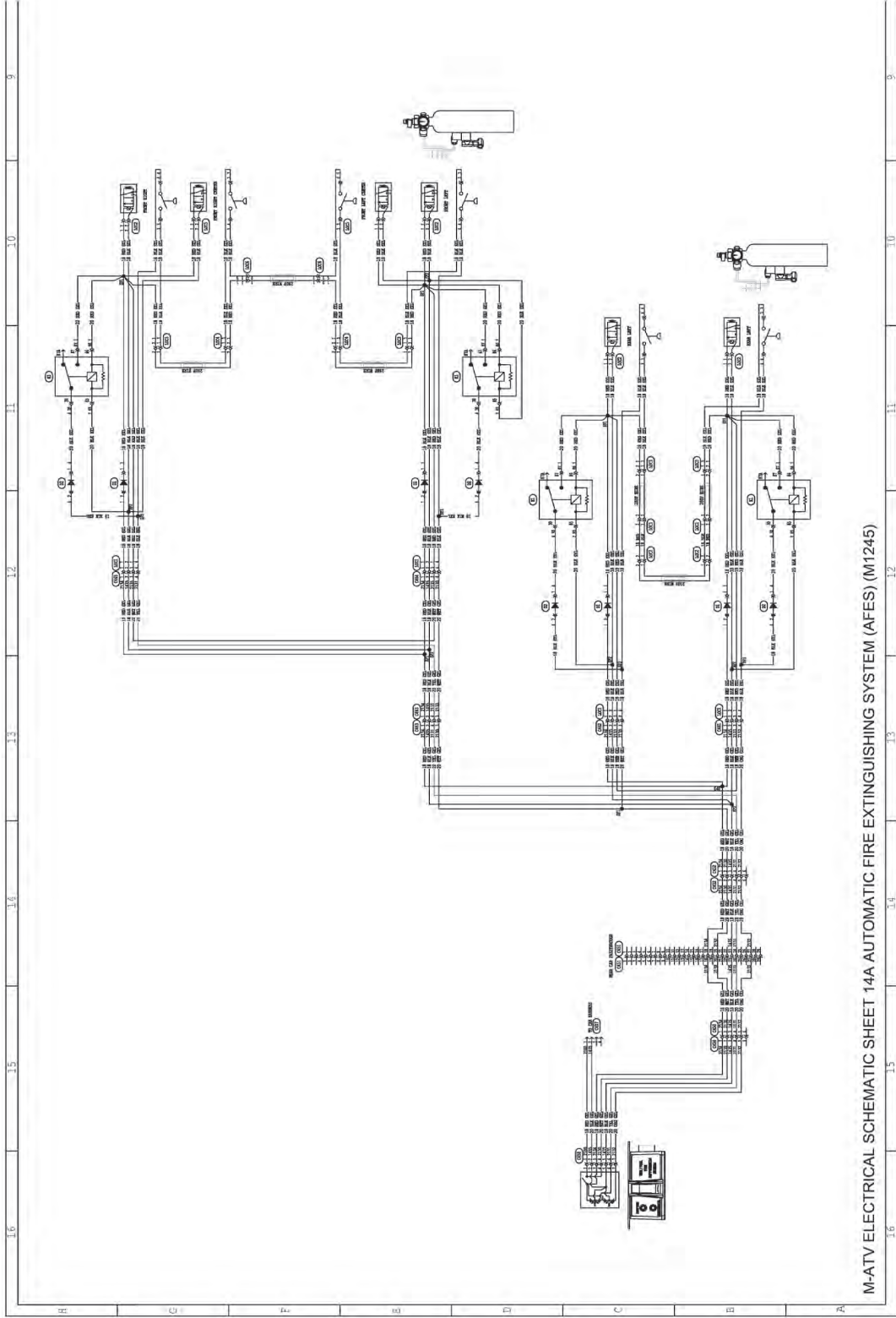

M-ATV ELECTRICAL SCHEMATIC SHEET 14A AUTOMATIC FIRE EXTINGUISHING SYSTEM (AFES) (M1245)



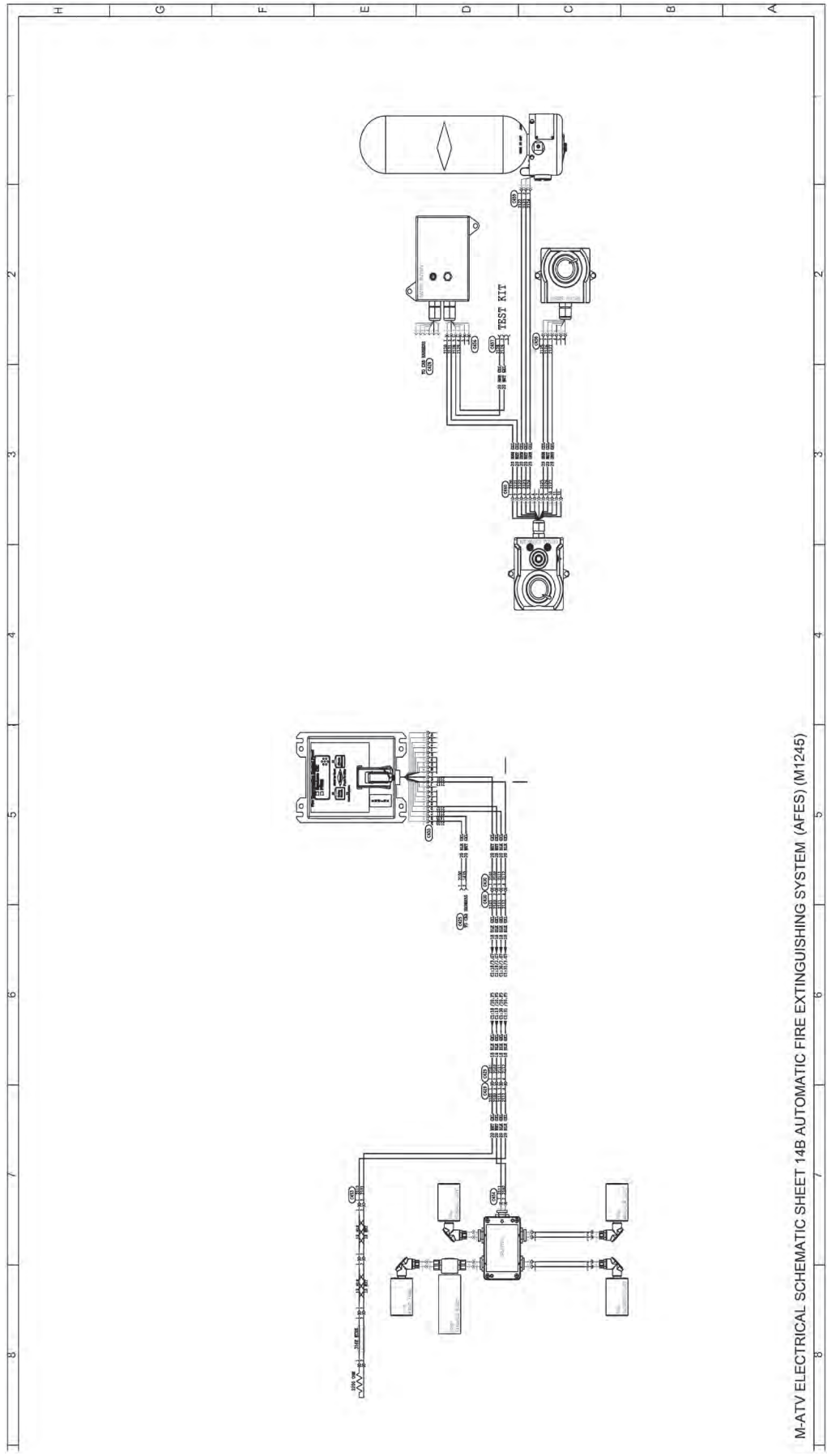

M-ATV ELECTRICAL SCHEMATIC SHEET 14B AUTOMATIC FIRE EXTINGUISHING SYSTEM (AFES) (M1245)





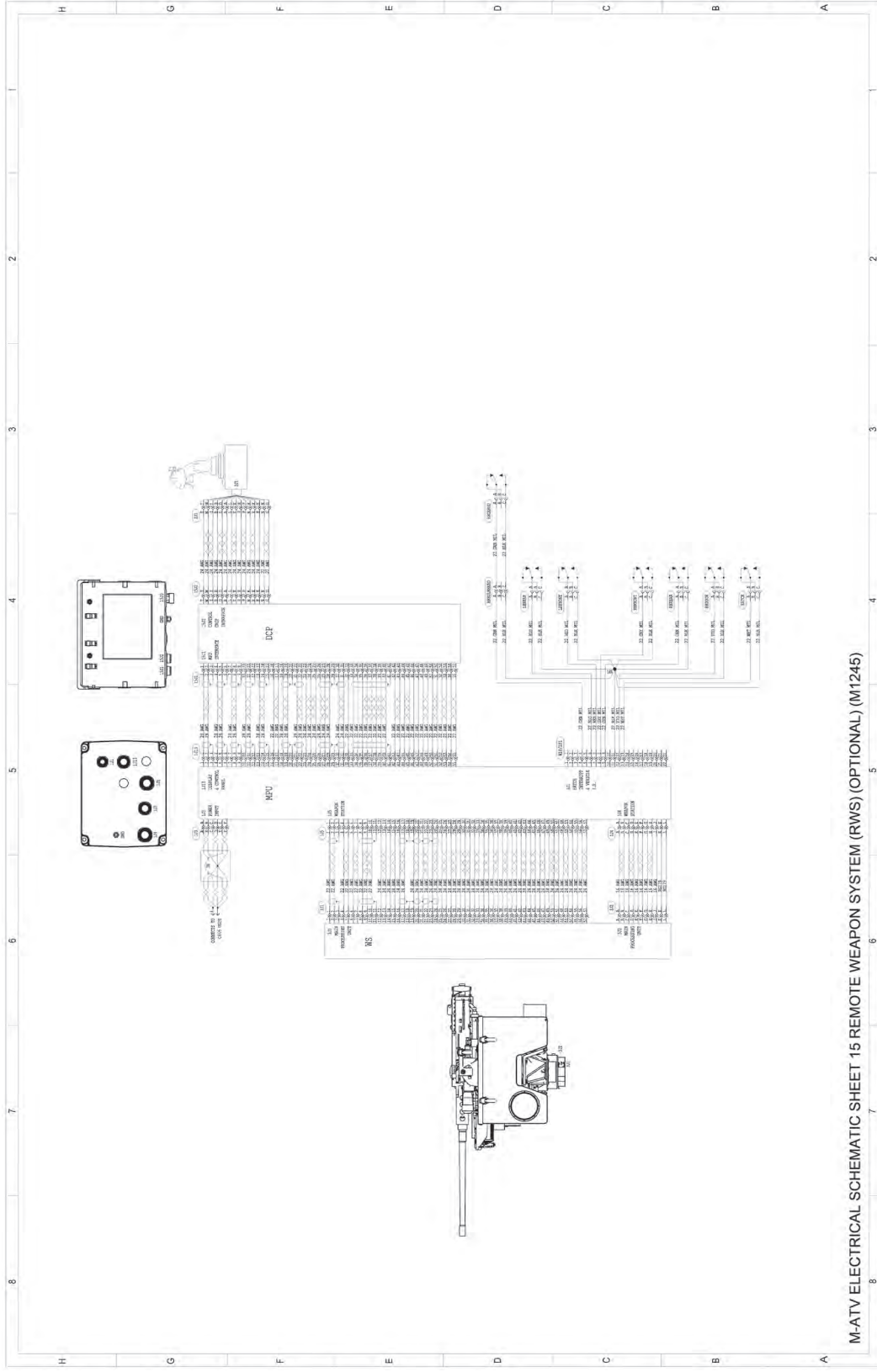

M-ATV ELECTRICAL SCHEMATIC SHEET 15 REMOTE WEAPON SYSTEM (RWS) (OPTIONAL) (M1245)



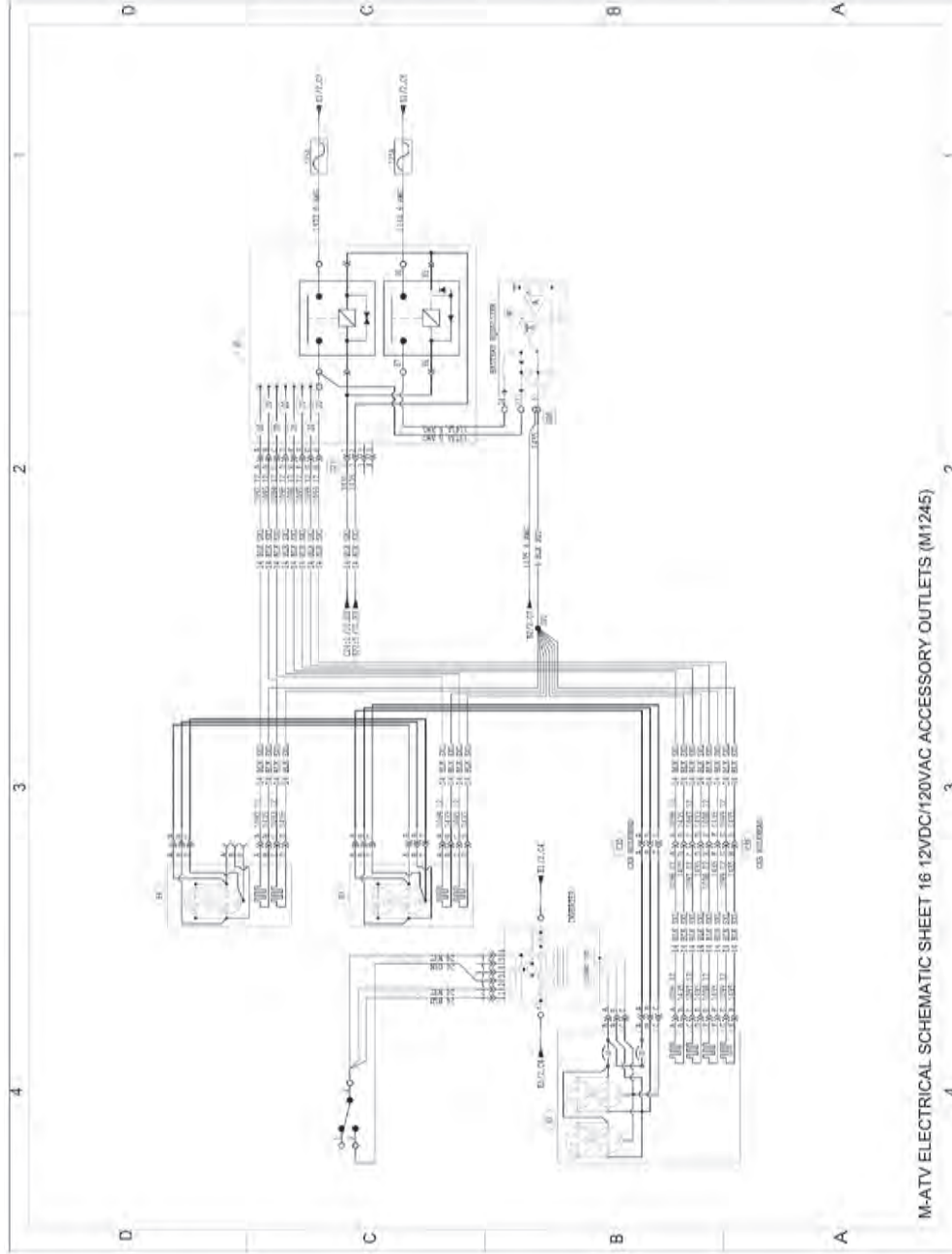

M-ATV ELECTRICAL SCHEMATIC SHEET 16 12VDC/120VAC ACCESSORY OUTLETS (M1245)



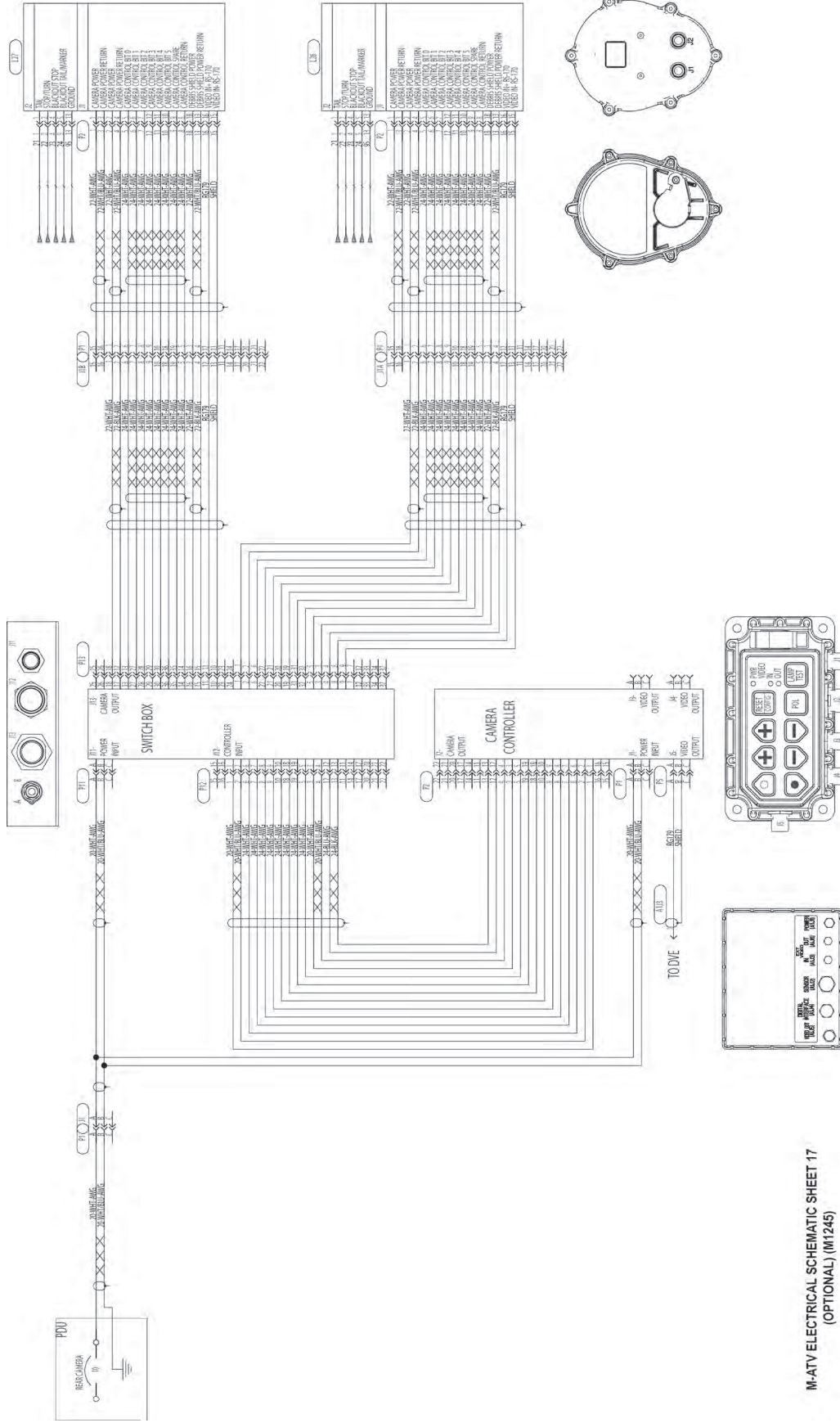

M-ATV ELECTRICAL SCHEMATIC SHEET 17  
(OPTIONAL) (M1245)





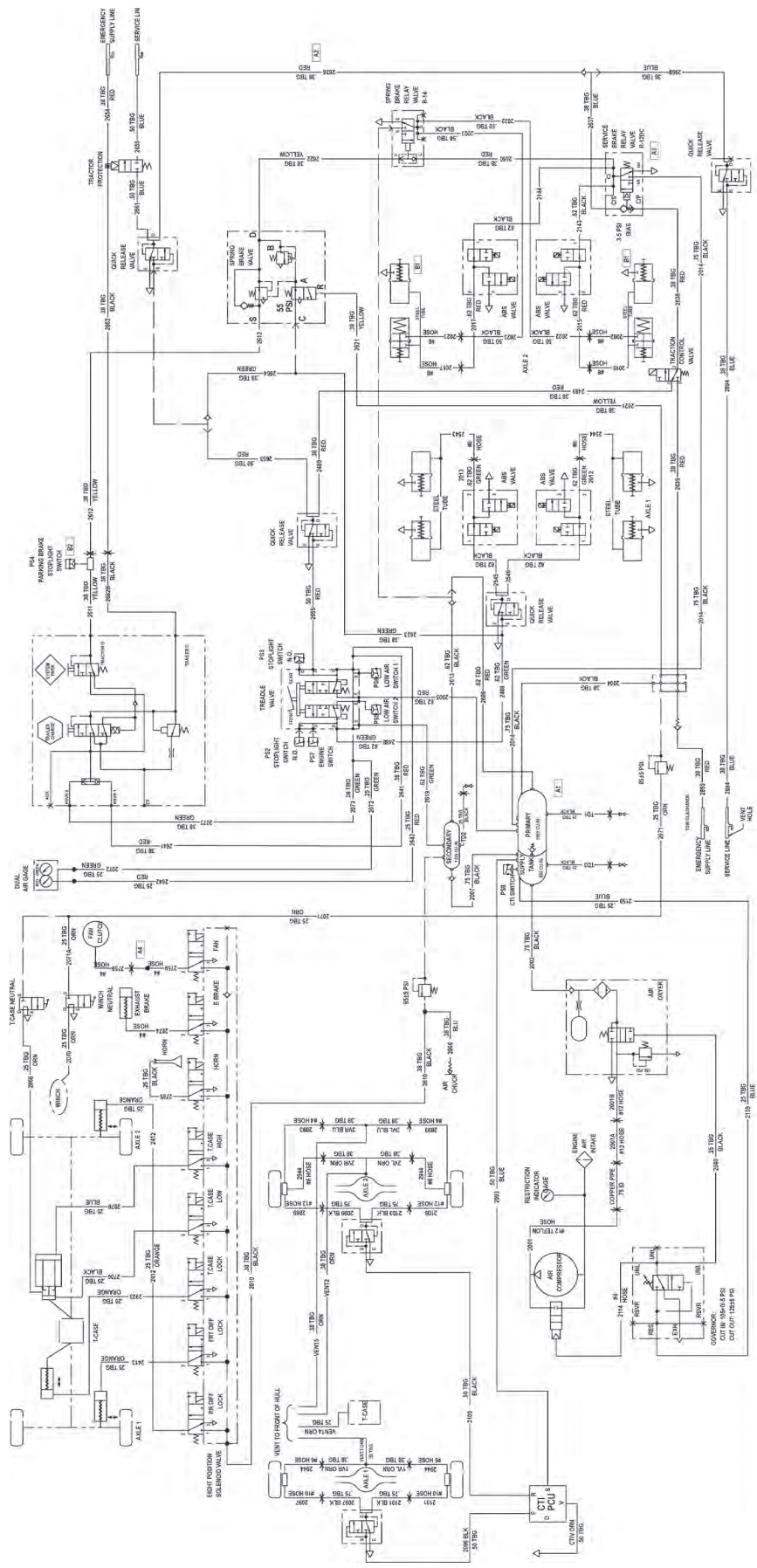

M-ATV AIR SCHEMATIC SHEET 18 (M1245)



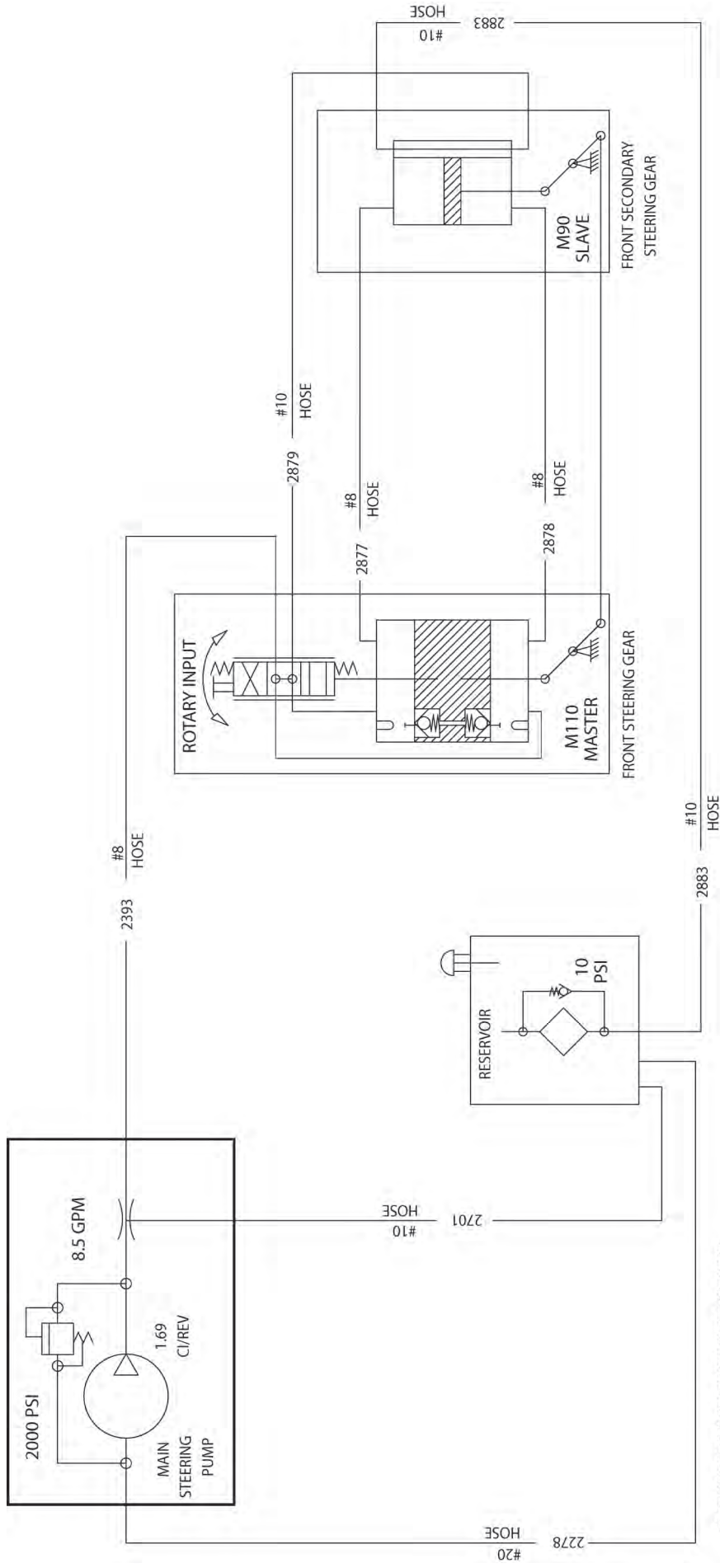

M-ATV HYDRAULIC SCHEMATIC SHEET 19 (M1245)



THE METRIC SYSTEM AND EQUIVALENTS

LINEAR MEASURE

1 Centimeter=10 Millimeters=0.01 Meters=0.3937 Inches  
 1 Meter=100 Centimeters=1000 Millimeters=39.37 Inches  
 1 Kilometer=1000 Meters=0.621 Miles

WEIGHTS

1 Gram=0.001 Kilograms=1000 Milligrams=0.035 Ounces  
 1 Kilogram=1000 Grams=2.2 Lb  
 1 Metric Ton=1000 Kilograms=1 Megagram=1.1 Short Tons

LIQUID MEASURE

1 Milliliter=0.001 Liters=0.0338 Fluid Ounces  
 1 Liter=1000 Milliliters=33.82 Fluid Ounces

SQUARE MEASURE

1 Sq Centimeter=100 Sq Millimeters=0.155 Sq Inches  
 1 Sq Meter=10,000 Sq Centimeters=10.76 Sq Feet  
 1 Sq Kilometer=1,000,000 Sq Meters=0.386 Sq Miles

CUBIC MEASURE

1 Cu Centimeter=1000 Cu Millimeters=0.06 Cu Inches  
 1 Cu Meter=1,000,000 Cu Centimeters=35.31 Cu Feet

TEMPERATURE

$5/9 (F - 32) = C$   
 212° Fahrenheit is equivalent to 100° Celsius  
 90° Fahrenheit is equivalent to 32.2° Celsius  
 32° Fahrenheit is equivalent to 0° Celsius  
 $9/5 C + 32 = F$

APPROXIMATE CONVERSION FACTORS

<u>TO CHANGE</u>	<u>TO</u>	<u>MULTIPLY BY</u>
Inches.....	Centimeters.....	2.540
Feet.....	Meters.....	0.305
Yards.....	Meters.....	0.914
Miles.....	Kilometers.....	1.609
Square Inches.....	Square Centimeters.....	6.451
Square Feet.....	Square Meters.....	0.093
Square Yards.....	Square Meters.....	0.836
Square Miles.....	Square Kilometers.....	2.590
Acres.....	Square Hectometers.....	0.405
Cubic Feet.....	Cubic Meters.....	0.028
Cubic Yards.....	Cubic Meters.....	0.765
Fluid Ounces.....	Milliliters.....	29.573
Pints.....	Liters.....	0.473
Quarts.....	Liters.....	0.946
Gallons.....	Liters.....	3.785
Ounces.....	Grams.....	28.349
Pounds.....	Kilograms.....	0.454
Short Tons.....	Metric Tons.....	0.907
Pound-Feet.....	Newton-Meters.....	1.356
Pounds/Sq Inch.....	Kilopascals.....	6.895
Miles per Gallon.....	Kilometers per Liter.....	0.425
Miles per Hour.....	Kilometers per Hour.....	1.609

<u>TO CHANGE</u>	<u>TO</u>	<u>MULTIPLY BY</u>
Centimeters.....	Inches.....	0.394
Meters.....	Feet.....	3.280
Meters.....	Yards.....	1.094
Kilometers.....	Miles.....	0.621
Sq Centimeters.....	Square Inches.....	0.155
Square Meters.....	Square Feet.....	10.764
Square Meters.....	Square Yards.....	1.196
Square Kilometers.....	Square Miles.....	0.386
Sq Hectometers.....	Acres.....	2.471
Cubic Meters.....	Cubic Feet.....	35.315
Cubic Meters.....	Cubic Yards.....	1.308
Milliliters.....	Fluid Ounces.....	0.034
Liters.....	Pints.....	2.113
Liters.....	Quarts.....	1.057
Liters.....	Gallons.....	0.264
Grams.....	Ounces.....	0.035
Kilograms.....	Pounds.....	2.205
Metric Tons.....	Short Tons.....	1.102
Newton-Meters.....	Pound-Feet.....	0.738
Kilopascals.....	Pounds per Sq Inch.....	0.145
Km per Liter.....	Miles per Gallon.....	2.354
Km per Hour.....	Miles per Hour.....	0.621



**PIN: 086720-000**